



© 2013 Intel Corporation

**Intel Open Source Graphics Programmer's Reference
Manual (PRM) for the 2013 Intel® Core™ Processor
Family, including Intel HD Graphics, Intel Iris™
Graphics and Intel Iris Pro Graphics**

Volume 7: 3D Media GPGPU Engine (Haswell)



Copyright

INFORMATION IN THIS DOCUMENT IS PROVIDED IN CONNECTION WITH INTEL® PRODUCTS. NO LICENSE, EXPRESS OR IMPLIED, BY ESTOPPEL OR OTHERWISE, TO ANY INTELLECTUAL PROPERTY RIGHTS IS GRANTED BY THIS DOCUMENT. EXCEPT AS PROVIDED IN INTEL'S TERMS AND CONDITIONS OF SALE FOR SUCH PRODUCTS, INTEL ASSUMES NO LIABILITY WHATSOEVER AND INTEL DISCLAIMS ANY EXPRESS OR IMPLIED WARRANTY, RELATING TO SALE AND/OR USE OF INTEL PRODUCTS INCLUDING LIABILITY OR WARRANTIES RELATING TO FITNESS FOR A PARTICULAR PURPOSE, MERCHANTABILITY, OR INFRINGEMENT OF ANY PATENT, COPYRIGHT OR OTHER INTELLECTUAL PROPERTY RIGHT.

A "Mission Critical Application" is any application in which failure of the Intel Product could result, directly or indirectly, in personal injury or death. SHOULD YOU PURCHASE OR USE INTEL'S PRODUCTS FOR ANY SUCH MISSION CRITICAL APPLICATION, YOU SHALL INDEMNIFY AND HOLD INTEL AND ITS SUBSIDIARIES, SUBCONTRACTORS AND AFFILIATES, AND THE DIRECTORS, OFFICERS, AND EMPLOYEES OF EACH, HARMLESS AGAINST ALL CLAIMS COSTS, DAMAGES, AND EXPENSES AND REASONABLE ATTORNEYS' FEES ARISING OUT OF, DIRECTLY OR INDIRECTLY, ANY CLAIM OF PRODUCT LIABILITY, PERSONAL INJURY, OR DEATH ARISING IN ANY WAY OUT OF SUCH MISSION CRITICAL APPLICATION, WHETHER OR NOT INTEL OR ITS SUBCONTRACTOR WAS NEGLIGENT IN THE DESIGN, MANUFACTURE, OR WARNING OF THE INTEL PRODUCT OR ANY OF ITS PARTS.

Intel may make changes to specifications and product descriptions at any time, without notice. Designers must not rely on the absence or characteristics of any features or instructions marked "reserved" or "undefined". Intel reserves these for future definition and shall have no responsibility whatsoever for conflicts or incompatibilities arising from future changes to them. The information here is subject to change without notice. Do not finalize a design with this information.

The products described in this document may contain design defects or errors known as errata which may cause the product to deviate from published specifications. Current characterized errata are available on request.

Implementations of the I2C bus/protocol may require licenses from various entities, including Philips Electronics N.V. and North American Philips Corporation.

Intel and the Intel logo are trademarks of Intel Corporation in the U.S. and other countries.

*Other names and brands may be claimed as the property of others.

Copyright © 2013, Intel Corporation. All rights reserved.



3D-Media-GPGPU Engine

Table of Contents

Render Engine Command Memory Interface	37
Registers in Render Engine	38
Mode and Misc Ctrl Registers	39
Pipelines Statistics Counter Registers.....	40
Predicate Render Registers.....	41
AUTO_DRAW Registers	42
MMIO Registers for GPGPU Indirect Dispatch.....	43
CS ALU	44
ALU PROGRAMMING.....	44
ALU DESIGN	44
Generic Purpose Registers	44
ALU BLOCK Diagram	45
Instruction Set.....	45
Instruction Format.....	46
LOAD Operation.....	46
Arithmetic/Logical Operations	47
STORE Operation	48
Summary for ALU.....	48
Summary of Instructions Supported	49
Table for ALU OPCODE Encodings	50
Table for Register Encodings.....	51
CS_GPR - Command Streamer General Purpose Registers.....	52
Memory Interface Commands for Rendering Engine.....	53
Predicated Rendering Support in HW.....	54
MI_SET_PREDICATE	55
State Commands	56
STATE_BASE_ADDRESS	56
Synchronization of the 3D Pipeline.....	57
Top-of-Pipe Synchronization	57



End-of-Pipe Synchronization	57
Synchronization Actions.....	58
Writing a Value to Memory.....	59
PS_DEPTH_COUNT	59
Generating an Interrupt.....	59
Invalidating of Caches	59
PIPE_CONTROL Command.....	60
PIPE_CONTROL.....	61
Programming Restrictions for PIPE_CONTROL	61
Post-Sync Operation	Error! Bookmark not defined.
Flush Types.....	62
Stall.....	63
Render Logical Context Data.....	64
Overall Context Layout.....	65
Context Layout.....	65
RegisterState Context	66
Command Ordering Rules.....	76
PIPELINE_SELECT.....	77
PIPE_CONTROL.....	78
URB-Related State-Setting Commands.....	79
Common Pipeline State-Setting Commands.....	80
3D Pipeline-Specific State-Setting Commands	81
Media Pipeline-Specific State-Setting Commands	82
3DPRIMITIVE.....	83
MEDIA_OBJECT.....	84
Resource Streamer.....	85
Resource Streamer Sync Commands	86
Hardware Binding Tables	87
3DSTATE_BINDING_TABLE_POOL_ALLOC	88
Gather Constants.....	89
3DSTATE_GATHER_POOL_ALLOC.....	96
3DSTATE_GATHER_CONSTANT_VS	97
3DSTATE_GATHER_HS	98



3DSTATE_GATHER_DS	100
3DSTATE_GATHER_CONSTANT_GS.....	101
3DSTATE_GATHER_CONSTANT_PS	103
Dx9 Constant Buffer Generation	104
Vertex Shader Constant	105
Pixel Shader Constant.....	106
Shared Functions	107
3D Sampler	107
Sampling Engine.....	109
Texture Coordinate Processing.....	111
Texture Coordinate Normalization	111
Texture Coordinate Computation	111
Texel Address Generation	113
Level of Detail Computation (Mipmapping).....	113
Base Level Of Detail (LOD).....	114
LOD Bias.....	114
LOD Pre-Clamping.....	114
Min/Mag Determination	115
LOD Computation Pseudocode.....	116
Inter-Level Filtering Setup.....	117
Intra-Level Filtering Setup.....	118
MAPFILTER_NEAREST	119
MAPFILTER_LINEAR.....	119
MAPFILTER_ANISOTROPIC	120
MAPFILTER_MONO.....	121
Texture Address Control	123
TEXCOORDMODE_MIRROR Mode.....	124
TEXCOORDMODE_WRAP Mode.....	124
TEXCOORDMODE_MIRROR_ONCE Mode.....	124
TEXCOORDMODE_CLAMP Mode	125
TEXCOORDMODE_CLAMPBORDER Mode	125
TEXCOORDMODE_CUBE Mode	125
Texel Fetch	126



Texel Chroma Keying.....	126
Chroma Key Testing.....	126
Chroma Key Effects.....	127
Shadow Prefilter Compare.....	128
Texel Filtering.....	129
Texel Color Gamma Linearization.....	130
Multisampled Surface Behavior.....	131
Multisample Control Surface.....	131
State.....	132
SURFACE_STATE for Deinterlace, sample_8x8, and VME.....	132
SAMPLER_STATE.....	132
Restrictions.....	133
Dispatch of Media Object Commands for VDIWalker Enabled.....	133
Media Object Dispatch Pseudocode.....	133
Calculate Residual Blocks Pseudocode.....	134
Dispatch Media Object Pseudocode.....	134
Border Color Programming for Integer Surface Formats.....	137
Messages.....	144
Initiating Message.....	144
Message Header.....	146
Payload Parameter Definition.....	148
Message Types.....	151
Parameter Types.....	158
Writeback Message.....	160
SIMD16.....	160
Return Format = 32-bit.....	160
Return Format = 16-bit.....	161
SIMD8/SIMD8D.....	162
Return Format = 32-bit.....	162
Return Format = 16-bit.....	163
SIMD4x2.....	163
Shared Functions – Data Port.....	165
Data Cache.....	166



Sampler Cache	167
Surfaces	168
Surface State Model.....	168
Stateless Model	168
Shared Local Memory (SLM)	169
Write Commit.....	170
Read/Write Ordering.....	171
Accessing Buffers.....	172
Accessing Media Surfaces.....	173
Boundary Behavior	173
State.....	174
BINDING_TABLE_STATE	174
SURFACE_STATE	174
Messages	175
Global Definitions	175
Data Port Messages	175
Message Descriptor	178
Message Descriptor	179
Message Header	183
Write Commit Writeback Message	184
OWord Block ReadWrite.....	184
Message Descriptor.....	185
Message Payload (Write).....	186
Writeback Message (Read).....	187
Unaligned OWord Block Read.....	187
Message Descriptor.....	188
Writeback Message (Read).....	188
OWord Dual Block ReadWrite	189
Message Descriptor.....	190
Message Payload.....	190
Additional Message Payload (Write)	191
Writeback Message (Read).....	191
Media Block Read/Write	191



Message Descriptor.....	194
Message Header.....	195
Message Payload (Write).....	199
Writeback Message (Read).....	199
DWord Scattered ReadWrite.....	199
Message Descriptor.....	201
Message Payload.....	202
Additional Message Payload (Write).....	203
Writeback Message (Read).....	204
Message Descriptor.....	204
Message Payload.....	205
Source Payload.....	206
Writeback Message.....	207
Byte Scattered ReadWrite.....	207
Message Descriptor.....	208
Message Payload.....	208
Additional Message Payload (Write).....	209
Writeback Message (Read).....	210
TypedUntyped Surface ReadWrite and TypedUntyped Atomic Operation.....	210
Typed Surface Read/Write Message Descriptor.....	217
Typed Surface Read/Write Message Descriptor.....	218
Untyped Surface ReadWrite Message Descriptor.....	219
Typed Atomic Operation Message Descriptor.....	219
Typed Atomic Operation SIMD4x2 Message Descriptor.....	220
Untyped Atomic Operation Message Descriptor.....	221
Untyped Atomic Operation SIMD4x2 Message Descriptor.....	222
Atomic Counter Operation Message Descriptor.....	223
Atomic Counter Operation SIMD4x2 Message Descriptor.....	224
Message Header.....	225
Message Payload.....	225
SIMD16 Address Payload.....	226
SIMD16 Source Payload (Atomic Operation Message Only).....	227
SIMD16 Source Payload (AOP_CMPWR8B Only).....	228



SIMD16 Write Data Payload (Write Message Only).....	229
SIMD8 Address Payload.....	229
SIMD8 Source Payload (Atomic Operation Message Only).....	230
SIMD8 Write Data Payload (Write Message Only)	231
SIMD8 Write Data Payload (Tile W Write Message Only)	232
SIMD4x2 Address Payload.....	232
SIMD4x2 Source Payload (Atomic Operation Message Only)	233
SIMD4x2 Source Payload (AOP_CMPWR8B Only).....	233
SIMD4x2 Write Data Payload (Write Message Only).....	234
Writeback Message	235
SIMD8 DWORD Read.....	235
SIMD8 QWORD Read	236
SIMD16 Read.....	237
SIMD8 Read	238
SIMD8 Read (Tile W)	239
SIMD4x2 Read.....	240
SIMD16 Atomic Operation.....	241
SIMD16 Atomic Operation (AOP_CMPWR8B Only).....	242
SIMD8 Atomic Operation	243
SIMD8 Atomic Operation (AOP_CMPWR8B Only)	244
SIMD4x2 Atomic Operation	245
SIMD4x2 Atomic Operation (AOP_CMPWR8B Only).....	246
Message Descriptor.....	246
Untyped Atomic Float Add Operation Message Descriptor	247
Message Header.....	248
Message Payload.....	249
SIMD16 Address Payload	249
SIMD8 Address Payload.....	250
SIMD16/SIMD8 DWORD Source Payload.....	251
SIMD16/SIMD8 QWORD Source Payload.....	252
Scratch Block Read or Write	253
Message Descriptor.....	254
Message Header.....	255



Message Payload (Write).....	255
Message Payload (Read)	255
Writeback Message (Read).....	255
Memory Fence	256
Message Descriptor.....	257
Message Header.....	257
Writeback Message	257
Pixel Data Port.....	258
Cache Agents	258
Accessing Render Targets	258
Message Sequencing Summary	258
Single Source	260
Dual Source	260
Replicate Data.....	261
Multiple Render Targets (MRT).....	261
Render Target Read and Write	261
Subspan/Pixel to Slot Mapping	264
Message Descriptor.....	266
Message Header	266
Message Header.....	266
Writeback Message (Read)	267
Header for SIMD8_IMAGE_WRITE.....	269
Source 0 Alpha Payload	272
oMask Payload	273
Color Payload: SIMD16 Single Source.....	274
Color Payload.....	274
Color Payload: SIMD8 Single Source	275
Color Payload SIMD16 Replicated Data	276
Color Payload SIMD8 Dual Source	276
Message Sequencing Summary.....	278
Message Sequencing Summary	278
Render Target Read and Write	279
Message Header	282



Cache Agents	283
Skin Tone Detection/Enhancement (STD/E).....	283
STD.....	283
Skin Tone Enhancement.....	285
Saturation Correction Enhancement.....	285
Hue Correction Enhancement.....	286
Skin Type Correction Enhancement.....	287
Transformation from (Sat, Hue) to (U, V).....	289
STD Score Output.....	289
Adaptive Contrast Enhancement (ACE).....	289
Total Color Control (TCC).....	290
ProcAmp.....	292
Color Space Conversion.....	294
Color Gamut Compression.....	295
Background of Color Gamut Compression.....	295
Usage Models.....	295
Gamut Compression Module Overview.....	296
xvYCC decoding.....	296
YUV2LCH.....	297
Out-of-Gamut Pixel Detection.....	297
Scaling Factor – Basic Mode.....	298
Fixed-Hue Compression.....	300
Scaling Factor – Advanced Mode.....	300
Shared Functions Pixel Interpolator.....	302
Messages.....	303
Initiating Message.....	303
Message Descriptor.....	303
<i>Per Message Offset</i> Message Descriptor.....	304
<i>Sample Position Offset</i> Message Descriptor.....	304
<i>Centroid Position and Per Slot Offset</i> Message Descriptor.....	305
Message Payload for Most Messages.....	305
SIMD8 Per Slot Offset Message Payload.....	305
SIMD16 Per Slot Offset Message Payload.....	306



Writeback Message.....	309
SIMD8	309
SIMD16.....	310
Shared Functions - Unified Return Buffer (URB).....	312
URB Size	313
URB Access.....	314
URB State.....	315
URB Messages	316
Execution Mask.....	317
Message Descriptor	317
URB_WRITE and URB_READ.....	318
Message Header.....	319
URB_WRITE_HWORD Write Data Payload.....	321
URB_NOSWIZZLE	322
URB_INTERLEAVED.....	323
URB_READ_HWORD Writeback Message.....	324
URB_NOSWIZZLE	324
URB_INTERLEAVED.....	325
URB_WRITE_OWORD Write Data Payload.....	326
URB_NOSWIZZLE	326
URB_INTERLEAVED.....	327
URB_READ_OWORD Writeback Message.....	328
URB_NOSWIZZLE	328
URB_INTERLEAVED.....	329
URB_ATOMIC.....	329
Message Header.....	330
Writeback Message	330
Message Gateway	331
Messages	332
Message Descriptor	332
OpenGateway Message.....	333
Message Payload.....	334
Writeback Message to Requester Thread	334



CloseGateway Message.....	335
Message Payload.....	335
Writeback Message to Requester Thread	335
ForwardMsg Message.....	336
Message Payload.....	336
Writeback Message to Requester Thread	338
Writeback Message to Recipient Thread	339
GetTimeStamp Message.....	339
Message Payload.....	339
Writeback Message to Requester Thread	340
BarrierMsg Message	341
Message Payload.....	341
Writeback Message to Requester Thread	342
Broadcast Writeback Message.....	342
MMIOReadWrite Message.....	343
Message Payload.....	343
Writeback Message to Requester Thread (MMIO Read Only)	343
Shared Functions - Media Sampler.....	345
Video Motion Estimation.....	346
Theory of Operation	346
Shape Decision.....	346
Minor Shape Decision Prior to FME	347
Major Shape Decision Prior to FME	350
Shape Update after FME.....	350
Final Code Decision after BME	350
Integer Motion Estimation.....	351
Reference Window and Search Units	351
Fixed and Adaptive Search Paths	353
Fractional Motion Estimation	357
Interpolations.....	357
8+8 vs. 7x7	358
Partitioning Refinement.....	358
BME and Weighted Prediction.....	359



Skip Check.....	359
Direct 8x8 Search.....	361
Skip Check Only Mode.....	362
Intra Prediction Estimation.....	362
Transform Adjusted SAD.....	362
Early Decisions.....	364
Performance Information.....	366
Changes.....	366
Surfaces.....	366
State.....	367
BINDING_TABLE_STATE.....	367
SURFACE_STATE.....	367
VME_STATE.....	367
VME_SEARCH_PATH_LUT_STATE.....	367
Haswell New Features Overview.....	371
IME Repartition (Dedicated IME Pipeline).....	371
HW Accelerated Chroma Intra.....	375
Improved Skip Decision (FTQ).....	375
HW Assisted Multi-Reference Support.....	376
Chroma Inter Mode.....	377
Increased SAD Precision.....	378
Legacy Feature Removal.....	378
Software Interface – PRM Highlights.....	379
Message Structure Overview.....	379
IME & IDM Message Descriptor.....	381
SIC and FBR Message Descriptor.....	382
Input GRFs.....	383
Input Message Phases by Type.....	383
Output GRFs.....	383
Output Message Phases by Type.....	384
Binding Table Pointers.....	385
Progressive Content.....	385
Interlaced Content.....	387



Glossary of Messages.....	390
Universal Input Message Phases.....	390
SIC Input Message Phases.....	413
IME Input Message Phases.....	419
FBR Input Message Phases.....	423
Return Data Message Phases.....	425
IME StreamOut.....	435
3D Pipeline Stages.....	436
3D Pipeline-Level State.....	437
Statistics.....	440
Statistics Gathering.....	440
3D Pipeline Geometry.....	442
Block Diagram.....	442
3D Primitives Overview.....	443
Vertex Data Overview.....	450
Vertex URB Entry (VUE) Formats.....	450
Vertex Positions.....	453
Clip Space Position.....	454
NDC Space Position.....	454
Screen-Space Position.....	454
3D Pipeline – Vertex Fetch (VF) Stage.....	455
Vertex Fetch (VF) Stage Overview.....	455
State.....	455
Control State.....	455
Index Buffer (IB) State.....	455
3DSTATE_INDEX_BUFFER.....	455
Vertex Buffers (VB) State.....	457
VERTEXDATA Buffers – SEQUENTIAL Access.....	457
VERTEXDATA Buffers – RANDOM Access.....	458
INSTANCEDATA Buffers.....	458
Vertex Definition State.....	459
Input Vertex Definition.....	459
Vertex Fetch State Preprocessing Extension.....	459



3D Primitive Command	460
Functions	460
Input Assembly.....	460
Vertex Assembly.....	460
Input Data: Push Model vs. Pull Model	461
Generated IDs.....	461
3D Primitive Processing	462
Functional Overview	462
CommandInit.....	462
InstanceLoop	463
VertexLoop	463
VertexIndexGeneration.....	463
Index Buffer Access.....	464
TerminatePrimitive	464
VertexCacheLookup.....	465
VertexElementLoop.....	465
Vertex Element Data Path	465
SourceElementFetch	466
FormatConversion	467
DestinationFormatSelection.....	470
PrimitiveInfoGeneration	470
URBWrite.....	472
OutputBufferedVertex	472
Dangling Vertex Removal	472
Statistics Gathering.....	472
Vertices Generated.....	472
Objects Generated	473
Vertex Shader (VS) Stage.....	474
VS Stage Overview	474
State	474
URB_FENCE	474
Functions	474
Vertex Shader Cache (VS\$)	474



SIMD4x2 VS Thread Request Generation	476
SIMD4x2 VS Thread Execution.....	476
Vertex Output	477
Thread Termination	477
Primitive Output	477
Statistics Gathering.....	477
Payloads.....	477
SIMD4x2 Payload	477
3D Pipeline – Hull Shader (HS) Stage	481
State	481
Functions	481
Patch Object Staging	481
HS Thread Execution.....	481
Dispatch Mask.....	482
Patch URB Entry (Patch Record) Output	482
Patch Header DW0-7	482
DOMAIN_POINT Structure.....	485
Statistics Gathering.....	487
HS Invocations	487
ICP Dereferencing	487
Payloads.....	488
SINGLE_PATCH Payload.....	488
HW Tessellation.....	493
State	493
Functions	494
Patch Culling	494
Tessellation Factor Limits	494
Partitioning	494
Domain Types and Output Topologies	495
QUAD Domain Tessellation	495
TRI Domain Tessellation.....	496
ISOLINE Domain Tessellation.....	497
Domain Shader (DS) Stage	499



State	499
Functions	500
SIMD4x2 Thread Execution	500
Statistics Gathering.....	500
Payloads.....	501
SIMD4x2 Payload	501
3D Pipeline – Geometry Shader (GS) Stage	505
GS Stage Overview	505
State	505
Functions	506
Object Staging.....	506
Thread Request Generation	506
Object Vertex Ordering.....	506
Thread Execution	510
Thread Execution	512
GS URB Entry	512
GS Output Topologies.....	513
GS Output StreamID.....	513
Primitive Output	514
Statistics Gathering.....	514
GS Invocations	514
Payloads.....	514
Thread Payload High-Level Layout	514
SIMD 4x2 Thread Payload.....	516
Thread Control Information.....	524
Thread Payload Generation	525
Fixed Payload Header.....	526
Extended Payload Header.....	528
Payload URB Data	528
3D Pipeline - Stream Output Logic (SOL) Stage	530
State	530
Functions	531
Input Buffering	531



Stream Output Function	534
Stream Output Buffers	535
Rendering Disable.....	535
Statistics	536
3D Pipeline Rasterization	537
3D Pipeline – CLIP Stage Overview	537
Clip Stage – General-Purpose Processing.....	537
Clip Stage – 3D Clipping	537
Fixed Function Clipper	538
Concepts.....	538
The Clip Volume	538
View Volume.....	538
User-Specified Clipping	540
Guard Band	540
NDC Guardband Parameters	542
Vertex-Based Clip Testing Considerations	543
Triangle Objects	543
Non-Wide Line Objects.....	544
Wide Line Objects	544
Wide Points.....	544
RECTLIST.....	545
3D Clipping	545
CLIP Stage Input.....	545
State.....	546
VUE Readback	546
VertexClipTest Function	546
Object Staging	551
Partial Object Removal.....	552
ClipDetermination Function.....	552
ClipMode	555
NORMAL ClipMode	556
CLIP_ALL ClipMode	556
CLIP_NON_REJECT ClipMode.....	556



REJECT_ALL ClipMode.....	556
ACCEPT_ALL ClipMode.....	556
Object Pass-Through.....	557
Primitive Output.....	558
Other Functionality.....	558
Statistics Gathering.....	558
CL_INVOCATION_COUNT.....	558
3D Pipeline - Strips and Fans (SF) Stage	559
Inputs from CLIP.....	559
Attribute Setup/Interpolation Process.....	560
Attribute Setup/Interpolation Process.....	560
Outputs to WM.....	560
Primitive Assembly	560
Point List Decomposition.....	564
Line List Decomposition	565
Line Strip Decomposition.....	566
Triangle List Decomposition	567
Triangle Strip Decomposition.....	568
Triangle Fan Decomposition.....	569
Polygon Decomposition.....	571
Rectangle List Decomposition	571
Object Setup.....	573
Invalid Position Culling (Pre/Post-Transform).....	573
Viewport Transformation.....	573
Destination Origin Bias.....	573
Point Rasterization Rule Adjustment	574
Drawing Rectangle Offset Application.....	575
Point Width Application.....	576
Rectangle Completion	577
Vertex XY Clamping and Quantization.....	578
Degenerate Object Culling.....	578
Triangle Orientation (Face) Culling.....	579
Scissor Rectangle Clipping.....	580



Line Rasterization.....	580
Zero-Width (Cosmetic) Line Rasterization	580
GIQ (Diamond) Sampling Rules – Legacy Mode.....	581
GIQ (Diamond) Sampling Rules – DX10 Mode.....	582
Non-Antialiased Wide Line Rasterization	584
Anti-Aliased Line Rasterization	585
3DSTATE_SF	586
SF_CLIP_VIEWPORT	586
Attribute Interpolation Setup	587
Attribute Swizzling.....	587
Interpolation Modes	588
Point Sprites	588
Depth Offset	590
Other SF Functions.....	591
Statistics Gathering	591
Other SF Functions	591
Statistics Gathering.....	591
Windower (WM) Stage	592
Overview	592
Inputs from SF to WM.....	592
Windower Pipelined State	593
3DSTATE_WM	593
3DSTATE_SAMPLE_MASK.....	593
Rasterization	593
Drawing Rectangle Clipping	594
Line Rasterization	594
Coverage Values for Anti-Aliased Lines.....	594
3DSTATE_AA_LINE_PARAMS	594
Line Stipple.....	595
Polygon (Triangle and Rectangle) Rasterization.....	596
Polygon Stipple	596
Multisampling	597
Multisample ModesState	597



Other WM Functions	602
Statistics Gathering.....	603
Other WM Functions.....	603
Statistics Gathering.....	603
Pixel.....	604
Early Depth/Stencil Processing	605
Depth Offset	605
Early Depth Test/Stencil Test/Write.....	606
Software-Provided PS Kernel Info	606
Hierarchical Depth Buffer	607
Depth Buffer Clear	608
Depth Buffer Resolve	610
Hierarchical Depth Buffer Resolve.....	610
Separate Stencil Buffer.....	611
DepthStencil Buffer State	611
Pixel Shader Thread Generation.....	612
3DSTATE_PS.....	612
Pixel Grouping (Dispatch Size) Control.....	612
Contiguous Dispatch Modes.....	614
Multisampling Effects on Pixel Shader Dispatch.....	615
MSDISPMODE_PERPIXEL Thread Dispatch.....	615
MSDISPMODE_PERSAMPLE Thread Dispatch.....	615
PS Thread Payload for Normal Dispatch	619
PS Thread Payload for Normal Dispatch.....	619
Pixel Backend	637
Color Calculator (Output Merger).....	637
Overview	637
Alpha Coverage.....	639
Alpha Test.....	639
Depth Coordinate Offset.....	640
Stencil Test.....	641
Depth Test.....	642
Pre-Blend Color Clamping.....	642



Pre-Blend Color Clamping When Blending is Disabled	643
Pre-Blend Color Clamping When Blending is Enabled	643
Color Buffer Blending	643
Post-Blend Color Clamping.....	646
Dithering.....	646
Logic Ops.....	647
Buffer Update.....	648
Stencil Buffer Updates	648
Depth Buffer Updates	649
Color Gamma Correction.....	649
Color Buffer Updates.....	650
Pixel Pipeline State Summary.....	650
COLOR_CALC_STATE	650
3DSTATE_BLEND_STATE_POINTERS	650
3DSTATE_DEPTH_STENCIL_STATE_POINTERS	650
COLOR_CALC_STATE	650
DEPTH_STENCIL_STATE	650
BLEND_STATE	650
CC_VIEWPORT.....	650
Other Pixel Pipeline Functions	650
Statistics Gathering	650
MCS Buffer for Render Target(s).....	651
Render Target Fast Clear.....	654
Render Target Resolve.....	654
L3/URB.....	656
L3\$/URB	656
L3\$ Cache Configuration.....	657
Memory Object Control State on Cacheability.....	657
Atomics	657
Atomics in L3.....	660
Atomics in SLM	660
Atomics in URB.....	660
L3 Allocation & Programming.....	660



Non-SLM Mode Allocation.....	661
SLM Mode Allocation	662
L3 Invalidation and Flush Flows	663
Read Only Stream Invalidations	663
Pipelined Flush for Writes.....	664
Global Invalidation.....	665
Shared Local Memory (SLM)	665
Dynamic Parity Feature for GFX L3 Cache.....	666
Feature Definition	666
Hardware and Software Flows	667
Parity Generation & Detection.....	667
Correction Using Parity Error data and Redundant Rows	667
Number of Corrections	668
Summary	668
Sub-banks with more than two persistent parity error rows	668
Interrupt Enabling	668
Clearing the Error Reporting Registers	669
Software Requirement on Silent Data Corruptions	669
Hardware Registers	669
Error Report Registers.....	670
L3CDERRST1 - L3CD Error Status Register 1.....	670
Row Replacement Registers.....	672
L3B0REG0 - L3 bank0 reg0 log error.....	672
L3 Register Space.....	673
SARERRST0 - SARB Error Status slice0.....	674
L3CDERRST01 - L3CD Error Status register 1 slice 0	676
L3CDERRST02 - L3CD Error Status register 2 slice 0	678
L3SQCREG1 - L3 SQC registers 1	680
L3SQCREG2 - L3 SQC registers 2	686
L3SQCREG3 - L3 SQC registers 3	688
L3CNTLREG1 - L3 Control Register1.....	693
L3CNTLREG2 - L3 Control Register2.....	695
L3CNTLREG3 - L3 Control Register3.....	697



L3SLMREG - L3 SLM Register	699
GARBCNTLREG - Arbiter Control Register	700
L3SQCREG4 - L3 SQC register 4	702
SCRATCH1 - SCRATCH1	703
LTIOREG - LTIO Register	705
CLMREDS0 - Column Redundancy Slice 0	706
LPCNTR1S0 - LPFC counter reg01 slice 0	707
LPCNTR2S0 - LPFC counter reg02 slice 0	707
LPCNTR3S0 - LPFC counter reg03 slice 0	707
LPCNTR4S0 - LPFC counter reg04 slice 0	708
LPCNTR5S0 - LPFC counter reg05 slice 0	708
LPCNTR6S0 - LPFC counter reg06 slice 0	708
LPCNTR7S0 - LPFC counter reg07 slice 0	709
LPCNTR8S0 - LPFC counter reg08 slice 0	709
L3B0REG00 - L3 bank0 reg0 log error slice 0.....	709
L3B0REG01 - L3 bank0 reg1 log error slice 0.....	710
L3B0REG02 - L3 bank0 reg2 log error slice 0.....	711
L3B0REG03 - L3 bank0 reg3 log error slice 0.....	712
L3B0REG04 - L3 bank0 reg4 log error slice0.....	714
L3B0REG05 - L3 bank0 reg5 log error slice0.....	715
L3B0REG06 - L3 bank0 reg6 log error slice 0.....	716
L3B0REG07 - L3 bank0 reg7 log error slice0.....	717
L3B1REG00 - L3 bank1 reg0 log error slice 0.....	718
L3B1REG01 - L3 bank1 reg1 log error slice 0.....	719
L3B1REG02 - L3 bank1 reg2 log error slice 0.....	720
L3B1REG03 - L3 bank1 reg3 log error slice 0.....	722
L3B1REG04 - L3 bank1 reg4 log error slice 0.....	724
L3B1REG05 - L3 bank1 reg5 log error slice 0.....	726
L3B1REG06 - L3 bank1 reg6 log error slice 0.....	728
L3B1REG07 - L3 bank1 reg7 log error slice 0.....	730
L3B2REG00 - L3 bank2 reg0 log error slice 0.....	732
L3B2REG01 - L3 bank2 reg1 log error slice 0.....	734
L3B2REG02 - L3 bank2 reg2 log error slice 0.....	736



L3B2REG03 - L3 bank2 reg3 log error slice 0.....	738
L3B2REG04 - L3 bank2 reg4 log error slice 0.....	740
L3B2REG05 - L3 bank2 reg5 log error slice 0.....	742
L3B2REG06 - L3 bank2 reg6 log error slice 0.....	744
L3B2REG07 - L3 bank2 reg7 log error slice 0.....	746
L3B3REG00 - L3 bank3 reg0 log error slice 0.....	748
L3B3REG01 - L3 bank3 reg1 log error slice 0.....	750
L3B3REG02 - L3 bank3 reg2 log error slice 0.....	751
L3B3REG03 - L3 bank3 reg3 log error slice 0.....	752
L3B3REG04 - L3 bank3 reg4 log error slice 0.....	753
L3B3REG05 - L3 bank3 reg5 log error slice 0.....	754
L3B3REG06 - L3 bank3 reg6 log error slice 0.....	756
L3B3REG07 - L3 bank3 reg7 log error slice 0.....	757
LPFCREG0 - First Buffer Size and Start.....	758
LPFCREG2 - Second Buffer Size.....	759
LPFCREG03 - Error Reporting Reg Slice 0.....	760
LPFCREG04 - Frame count and Draw call number.....	761
LPFCREG05 - SAVE Timer.....	762
L3 Performance Counter Event Table.....	763
LPFCREG06 - Event selection and base counters.....	765
LPFCREG07 - Event Selection and Base Counters1.....	767
LPFCREG08 - MASTER start Timer.....	768
L3SYNC - L3 Cross Sync Control Register.....	768
slmmsg - slm context save/restore msg.....	769
SARBCSR - SARB config save msg.....	769
SARERRST1 - SARB Error Status slice1.....	770
L3CDERRST11 - L3CD Error Status register 1 slice 1.....	772
L3CDERRST12 - L3CD Error Status register 2 slice 1.....	773
CLMREDS1 - Column Redundancy Slice 1.....	774
LPCNTR1S1 - LPFC counter reg01 slice 1.....	775
LPCNTR2S1 - LPFC counter reg02 slice 1.....	775
LPCNTR3S1 - LPFC counter reg03 slice 1.....	776
LPCNTR4S1 - LPFC counter reg04 slice 1.....	776



LPCNTR5S1 - LPFC counter reg05 slice 1	776
LPCNTR6S1 - LPFC counter reg06 slice 1	776
LPCNTR7S1 - LPFC counter reg07 slice 1	777
L3B0REG10 - L3 bank0 reg0 log error slice 1	777
L3B0REG11 - L3 bank0 reg1 log error slice 1	778
L3B0REG12 - L3 bank0 reg2 log error slice 1	779
L3B0REG13 - L3 bank0 reg3 log error slice 1	780
L3B0REG14 - L3 bank0 reg4 log error slice1	781
L3B0REG15 - L3 bank0 reg5 log error slice1	783
L3B0REG16 - L3 bank0 reg6 log error slice 1	784
L3B0REG17 - L3 bank0 reg7 log error slice1	785
L3B1REG10 - L3 bank1 reg0 log error slice 1	786
L3B1REG11 - L3 bank1 reg1 log error slice 1	788
L3B1REG12 - L3 bank1 reg2 log error slice 1	790
L3B1REG13 - L3 bank1 reg3 log error slice 1	792
L3B1REG14 - L3 bank1 reg4 log error slice 1	793
L3B1REG15 - L3 bank1 reg5 log error slice 1	794
L3B1REG16 - L3 bank1 reg6 log error slice 1	795
L3B1REG17 - L3 bank1 reg7 log error slice 1	796
L3B2REG10 - L3 bank2 reg0 log error slice 1	798
L3B2REG11 - L3 bank2 reg1 log error slice 1	799
L3B2REG12 - L3 bank2 reg2 log error slice 1	800
L3B2REG13 - L3 bank2 reg3 log error slice 1	801
L3B2REG14 - L3 bank2 reg4 log error slice 1	802
L3B2REG15 - L3 bank2 reg5 log error slice 1	804
L3B2REG16 - L3 bank2 reg6 log error slice 1	805
L3B2REG17 - L3 bank2 reg7 log error slice 1	806
L3B3REG10 - L3 bank3 reg0 log error slice 1	807
L3B3REG11 - L3 bank3 reg1 log error slice 1	808
L3B3REG12 - L3 bank3 reg2 log error slice 1	810
L3B3REG13 - L3 bank3 reg3 log error slice 1	811
L3B3REG14 - L3 bank3 reg4 log error slice 1	812
L3B3REG15 - L3 bank3 reg5 log error slice 1	813



L3B3REG16 - L3 bank3 reg6 log error slice 1.....	814
L3B3REG17 - L3 bank3 reg7 log error slice 1.....	816
LPFCREG13 - Error Reporting Reg Slice 1.....	817
LPCNTR8S1 - LPFC counter reg08 slice 1	818
Media GPGPU Pipeline.....	819
GPGPU Overview	819
Programming the GPGPU Pipeline.....	819
GPGPU Thread Limits	819
GPGPU Commands.....	820
GPGPU Indirect Thread Dispatch	821
GPGPU Context Switch.....	823
GPGPU Context Switch.....	825
Media GPGPU Payload Limitations.....	826
Synchronization of the Media/GPGPU Pipeline	827
Mode of Operations	828
GPGPU Thread R0 Header.....	828
GPGPU Mode [Project: IVB+, VLVT].....	830
Automatic Thread Generation.....	830
Thread Payload	831
Execution Masks	832
Payload Storage.....	834
URB Management.....	836
Thread Group Tracking.....	837
Shared Local Memory Allocation	838
Software Managed Shared Local Memory	839
Automatic Barrier Management.....	840
Local Memory/Scratch Space	841
Dispatch Payload	842
Generic Media	843
Product Evolution.....	845
Media and General Purpose Pipeline	846
Introduction	846
Terminologies.....	846



Hardware Feature Map in Products.....	848
Media Pipeline Overview.....	850
Generic Mode.....	851
GPGPU Media Pipe Differences.....	851
Programming Media Pipeline.....	852
Command Sequence.....	852
Command Sequence.....	852
Parameterized Media Walker.....	854
Walker Parameter Description.....	855
Basic Parameters for the Local Loop.....	856
Dual Mode of Local Loop.....	857
MbAff-Like Special Case in Local Loop.....	858
Global Loop.....	859
Walker Algorithm Description.....	860
Scoreboard Control.....	865
AVC-Style Dependency Example.....	865
VC1-Style Dependency Example.....	867
Multiple Slice Considerations.....	868
Interrupt Latency.....	868
Thread Spawner Unit.....	869
Root Threads and Child Threads.....	870
Root Threads.....	870
URB Handles.....	870
Root to Child Responsibilities.....	871
Multiple Simultaneous Roots.....	871
Synchronized Root Threads.....	872
Deadlock Prevention.....	872
Child Thread Life Cycle.....	873
Arbitration between Root and Child Threads.....	874
Persistent Root Thread.....	874
Media State Model.....	875
Media State and Primitive Commands.....	876
Media Messages.....	877



Thread Payload Messages.....	877
Generic Mode Root Thread.....	877
Root Thread from MEDIA_OBJECT_PRT	879
Root Thread from MEDIA_OBJECT_WALKER.....	881
Thread Spawn Message	881
Message Descriptor.....	883
Message Payload.....	883
EU Overview.....	886
Primary Usage Models	888
AOS and SOA Data Structures	889
SIMD4 Mode of Operation	891
SIMD4x2 Mode of Operation	892
SIMD16 Mode of Operation.....	894
SIMD8 Mode of Operation.....	896
Message Payload Containing a Header.....	897
Writebacks.....	898
Message Delivery Ordering Rules.....	899
Execution Mask and Messages	900
End-Of-Thread (EOT) Message	901
Message Description Syntax.....	902
Message Errors	903
Registers and Register Regions.....	905
Register Files	905
GRF Registers	906
ARF Registers	907
ARF Registers Overview.....	907
Access Granularity	908
Null Register	908
Address Register	909
Accumulator Registers.....	912
Flag Register	915
Channel Enable Register	916
SP Register.....	917



State Register	918
Control Register.....	921
Notification Registers.....	927
IP Register	929
TDR Registers	929
Performance Registers.....	932
Flow Control Registers.....	934
Immediate	935
Region Parameters.....	936
Region Addressing Modes	941
Direct Register Addressing.....	941
Register-Indirect Register Addressing with a 1x1 Index Region.....	942
Register-Indirect Register Addressing with a Vx1 Index Region	943
Register-Indirect Register Addressing with a VxH Index Region.....	944
Access Modes	946
Execution Data Type.....	947
Register Region Restrictions	948
Destination Operand Description	952
Destination Region Parameters.....	952
SIMD Execution Control	953
Predication	953
No Predication.....	955
Predication with Horizontal Combination	956
Predication with Vertical Combination	958
End of Thread	959
Assigning Conditional Flags.....	960
Destination Hazard.....	963
Non-present Operands.....	964
Instruction Prefetch.....	965
ISA Introduction.....	966
Introducing the Execution Unit.....	967
EU Terms and Acronyms.....	970
Execution Units (EUs).....	974



EU Changes by Processor Generation	975
EU Notation.....	977
EU Data Types.....	978
Fundamental Data Types	978
Numeric Data Types	979
Integer Numeric Data Types.....	979
Floating-Point Numeric Data Types.....	981
Packed Signed Half-Byte Integer Vector	982
Packed UnSigned Half-Byte Integer Vector.....	983
Packed Restricted Float Vector.....	984
Floating Point Modes	986
IEEE Floating Point Mode.....	987
Partial Listing of Honored IEEE-754 Rules	987
Complete Listing of Deviations or Additional Requirements vs. IEEE-754	988
Comparison of Floating Point Numbers.....	989
Min Max of Floating Point Numbers	991
Alternative Floating Point Mode.....	991
Type Conversion.....	994
Float to Integer.....	994
Integer to Integer with Same or Higher Precision	994
Integer to Integer with Lower Precision	995
Integer to Float.....	995
Double Precision Float to Single Precision Float	995
Single Precision Float to Double Precision Float	995
Exceptions.....	997
Exception-Related Architecture Registers.....	998
System Routine.....	999
Invoking the System Routine.....	999
Returning to the Application Thread.....	1000
System IP (SIP).....	1001
System Routine Register Space	1001
Conditional Instructions Within the System Routine	1001
Use of NoDDClr	1002



Exception Descriptions	1004
Illegal Opcode	1004
Undefined Opcodes	1004
Software Exception	1004
Context Save and Restore.....	1004
Events That Do Not Generate Exceptions	1006
Illegal Instruction Format	1006
Malformed Message	1006
GRF Register Out of Bounds	1006
Hung Thread	1006
Instruction Fetch Out of Bounds	1006
FPU Math Errors.....	1007
Computational Overflow	1007
Instruction Set Summary	1008
Instruction Set Characteristics	1008
SIMD Instructions and SIMD Width	1008
Instruction Operands and Register Regions.....	1008
Instruction Execution	1009
Instruction Machine Formats	1009
EU Instruction Formats.....	1012
Common Instruction Fields	1018
Instruction Operation Doubleword (DW0).....	1024
Instruction Destination Doubleword (DW1).....	1029
DW1 1-src and 2-src Instructions.....	1029
DW1 3-src Instructions	1033
Instruction Source 0 Doubleword 2 (DW2).....	1035
DW2 1-src and 2-src Instructions.....	1035
Instruction Source 1 Doubleword 3 (DW3).....	1040
EU Compact Instructions	1044
EU Compact Instruction Format	1045
EU Instruction Compaction Tables	1047
Opcode Encoding	1051
Move and Logic Instructions	1051



Flow Control Instructions	1053
Miscellaneous Instructions	1054
Parallel Arithmetic Instructions.....	1055
Vector Arithmetic Instructions	1056
Special Instructions.....	1057
Native Instruction BNF.....	1058
Instruction Groups	1058
Source Register	1060
Address Registers.....	1061
Register Files and Register Numbers	1061
Relative Location and Stack Control.....	1062
Regions.....	1063
Types	1063
Write Mask.....	1063
Swizzle Control.....	1063
Immediate Values.....	1063
Predication and Modifiers.....	1064
Instruction Options.....	1065
Instruction Set Summary Tables	1066
Accumulator Restrictions.....	1072
Instruction Set Reference	1075
Conventions	1075
Pseudo Code Format.....	1075
General Macros and Definitions.....	1075
Evaluate Write Enable	1076
EUISA Instructions	1077
EUISA Structures.....	1078
EUISA Enumerations	1079
EU Programming Guide.....	1081
Assembler Pragmas.....	1081
Declarations	1081
Defaults and Defines	1082
Example Pragma Usages.....	1083



Assembly Programming Guideline	1084
Usage Examples.....	1086
Vector Immediate.....	1086
Supporting DirectX 10 Pixel Shader Indexing.....	1086
Supporting OpenGL Vertex Shader Instruction SWZ.....	1087
Destination Mask for DP4 and Destination Dependency Control	1088
Null Register as the Destination.....	1089
Use of LINE Instruction	1089
Mask for SEND Instruction	1090
Channel Enables for Extended Math Unit.....	1090
Channel Enables for Scratch Memory	1092
Flow Control Instructions.....	1094
Execution Masking.....	1095
Branching.....	1095
Fast-If.....	1095
Cascade Branching.....	1096
Compound Branches.....	1097
Looping.....	1098
Indexed Jump.....	1102





Render Engine Command Memory Interface

This chapter describes the memory-mapped registers associated with the Memory Interface, including brief descriptions of their use. The functions performed by some of these registers are discussed in more detail in the *Memory Interface Functions*, *Memory Interface Instructions*, and *Programming Environment* chapters.

The registers detailed in this chapter are used across the family of products and are extensions to previous projects. However, slight changes may be present in some registers (i.e., for features added or removed), or some registers may be removed entirely. These changes are clearly marked within this chapter.



Registers in Render Engine

This chapter describes the memory-mapped registers associated with the Memory Interface, including brief descriptions of their use. The functions performed by some of these registers are discussed in more detail in the *Memory Interface Functions*, *Memory Interface Instructions*, and *Programming Environment* chapters.

The registers detailed in this chapter are used across the family of products and are extensions to previous projects. However, slight changes may be present in some registers (i.e., for features added or removed), or some registers may be removed entirely. These changes are clearly marked within this chapter.



Mode and Misc Ctrl Registers

This section contains various registers for controls and modes.



Pipelines Statistics Counter Registers

These registers keep continuous count of statistics regarding the 3D pipeline. They are saved and restored with context but should not be changed by software except to reset them to 0 at context creation time. Write access to the statistics counter in this section must be done through MI_LOAD_REGISTER_IMM, MI_LOAD_REGISTER_MEM, or MI_LOAD_REGISTER_REG commands in ring buffer or batch buffer. These registers may be read at any time; however, to obtain a meaningful result, a pipeline flush just prior to reading the registers is necessary to synchronize the counts with the primitive stream.

IA_VERTICES_COUNT - IA Vertices Count

IA_PRIMITIVES_COUNT - Primitives Generated By VF

VS_INVOCATION_COUNT - VS Invocation Counter

HS_INVOCATION_COUNT - HS Invocation Counter

DS_INVOCATION_COUNT - DS Invocation Counter

GS_INVOCATION_COUNT - GS Invocation Counter

GS_PRIMITIVES_COUNT - GS Primitives Counter

CL_INVOCATION_COUNT - Clipper Invocation Counter

PS_INVOCATION_COUNT - PS Invocation Count

TIMESTAMP - Reported Timestamp Count

SO_NUM_PRIMS_WRITTEN[0:3] - Stream Output Num Primitives Written Counter

SO_PRIM_STORAGE_NEEDED[0:3] - Stream Output Primitive Storage Needed Counters

SO_WRITE_OFFSET[0:3] - Stream Output Write Offsets



Predicate Render Registers

MI_PREDICATE_SRC0 - Predicate Rendering Temporary Register0

MI_PREDICATE_SRC1 - Predicate Rendering Temporary Register1

MI_PREDICATE_DATA - Predicate Rendering Data Storage

MI_PREDICATE_RESULT - Predicate Rendering Data Result

MI_PREDICATE_RESULT_1 - Predicate Rendering Data Result 1

MI_PREDICATE_RESULT_2 - Predicate Rendering Data Result 2



AUTO_DRAW Registers

3DPRIM_END_OFFSET - Auto Draw End Offset

3DPRIM_START_VERTEX - Load Indirect Start Vertex

3DPRIM_VERTEX_COUNT - Load Indirect Vertex Count

3DPRIM_INSTANCE_COUNT - Load Indirect Instance Count

3DPRIM_START_INSTANCE - Load Indirect Start Instance

3DPRIM_BASE_VERTEX - Load Indirect Base Vertex



MMIO Registers for GPGPU Indirect Dispatch

These registers are normally written with the MI_LOAD_REGISTER_MEMORY command rather than from the CPU.

Project:	HSW
<p>These registers should not be written with 0 for these projects. To avoid this, the MI_LOAD_REGISTER_MEMORY command which writes them from an address in memory which was written by a previous GPGPU_WALKER command will need to be checked with the following command sequence:</p> <pre data-bbox="134 646 1377 919">MI_LOAD_REGISTER_MEMORY Xaddress, GPGPU_DISPATCHDIMX MI_CONDITIONAL_BATCH_BUFFER_END Xaddress, 0 // Compare X dimension to 0, end batch buffer if 0 MI_LOAD_REGISTER_MEMORY GPGPU_DISPATCHDIMY MI_CONDITIONAL_BATCH_BUFFER_END Yaddress, 0 // Compare Y dimension to 0, end batch buffer if 0 MI_LOAD_REGISTER_MEMORY GPGPU_DISPATCHDIMZ MI_CONDITIONAL_BATCH_BUFFER_END Zaddress, 0 // Compare Z dimension to 0, end batch buffer if 0 GPGPU_WALKER // Walker with indirect dispatch</pre> <p>This way, if any dimension is 0 we would not execute the GPGPU_WALKER. This has the limitation that the indirect GPGPU_WALKER has to be the last WALKER of the batch buffer.</p>	

GPGPU_DISPATCHDIMX - GPGPU Dispatch Dimension X

GPGPU_DISPATCHDIMY - GPGPU Dispatch Dimension Y

GPGPU_DISPATCHDIMZ - GPGPU Dispatch Dimension Z

TS_GPGPU_THREADS_DISPATCHED - Count Active Channels Dispatched



CS ALU

ALU PROGRAMMING

ALU DESIGN

Command streamer implements a rudimentary ALU which supports basic Arithmetic (Addition and Subtraction) and logical operations (AND, OR, XOR) on two 64bit operands. ALU has two 64bit registers at the input SRCA and SRCB to which the operands should be loaded on which operations will be performed and outputted to a 64 bit Accumulator. Zero Flag and Carry Flag are set based on accumulator output.

Generic Purpose Registers

Command streamer implements sixteen 64 bit General Purpose Registers which are MMIO mapped. These registers can be accessed similar to any other MMIO mapped registers through LRI, SRM, LRR, LRM or CPU access path for reads and writes. These registers will be labeled as R0, R1, ... R15 throughout the discussion. Refer table in the B-spec update section mapping these registers to corresponding MMIO offset. A selected GPR register can be moved to SRCA or SRCB register using "LOAD" instruction. Outputs of the ALU, Accumulator, ZF and CF can be moved to any of the GPR using "STORE" instruction.

ALU BLOCK Diagram

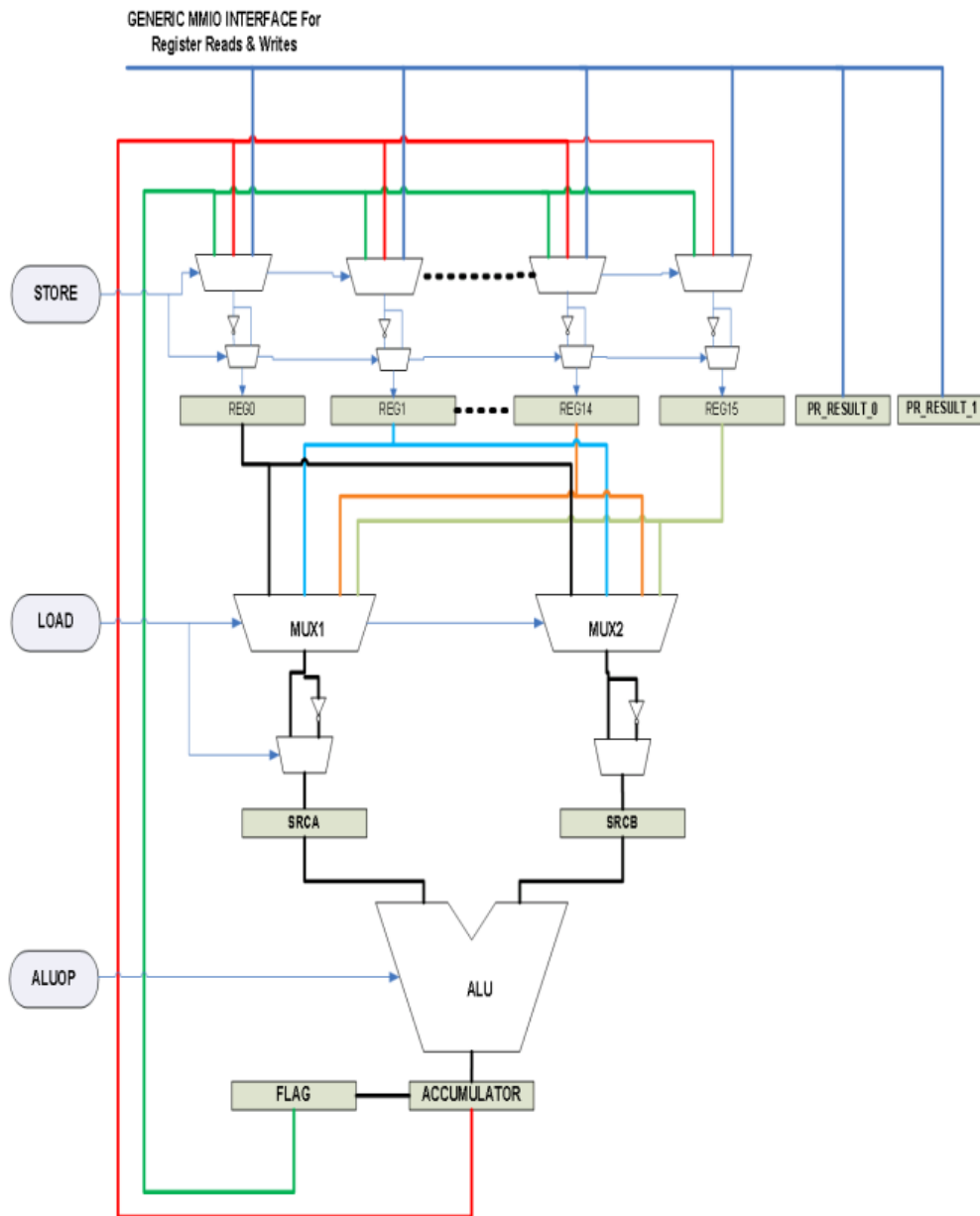

Instruction Set

The instructions supported by the ALU can be broadly categorized into three groups:

- To move data from GPR to SRCA/SRCB – LOAD instruction.
- To move data from ACCUMULATOR/CF/ZF to GPR – STORE Instruction.
- To do arithmetic/Logical operations on SRCA and SRCB of ALU - ADD/SUB/AND/XOR/OR.



Instruction Format

Each instruction is one Dword in size and consists of an ALU OPCODE, OPERAND1 and OPERAND2 in the format shown below.

ALU OPCODE	Operand-1	Operand-2
12 bits	10 bits	10 bits

LOAD Operation

The LOAD instruction moves the content of the destination register (Operand2) into the source register (Operand1). The destination register can be any of the GPR (R0, R1, ..., R15) and the source registers are SRCA and SRCB of the ALU. This is the only means SRCA and SRCB can be programmed.

LOAD has different flavors, wherein one can load the inverted version of the source register into the destination register or a hard coded value of all Zeros and All ones.

```
// Loads any of Reg0 to Reg15 into the SRCA or SRCB registers of ALU.
```

- LOAD <SRCA, SRCB>, < REG0..REG15>

```
// Loads inverted (bit wise) value of the mentioned Reg0 to 15 into SRCA or SRCB registers of ALU.
```

- LOADINV <SRCA, SRCB>, < REG0..REG15>

```
//LOADS "0" into SRCA or SRCB
```

- LOAD0 <SRCA, SRCB>

```
//Loads all '1' into SRCA or SRCB
```

- LOAD1 <SRCA, SRCB>

31	20	19	10	9	0
Opcode		Operand1		Operand2	
LOAD		SRCA/SRCB		R0,R1..R15	
LOADINV		SRCA/SRCB		R0,R1..R15	



LOAD0	SRCA/SRCB	N/A
LOAD1	SRCA/SRCB	N/A

Arithmetic/Logical Operations

ADD, SUB, AND, OR, and XOR are the Arithmetic and Logical operations supported by Arithmetic Logic Unit (ALU). When opcode corresponding to a logical operation is performed on SRCA and SRCB, the result is sent to ACCUMULATOR (ACCU), CF and ZF. Note that ACCU is 64-bit register. A NOOP when submitted to the ALU doesn't do anything, it is meant for creating bubble or kill cycles.

31	20	19	10	9	0
Opcode		Operand1		Operand2	
ADD		N/A		N/A	
SUB		N/A		N/A	
AND		N/A		N/A	
OR		N/A		N/A	
XOR		N/A		N/A	
NOOP		N/A		NA	



STORE Operation

Store instruction moves the content of the destination register (Operand1) in to source register (Operand2). Destination register can be accumulator (ACCU), CF or ZF and destination register being GPR (R0, R1 ..R15). STORE has different flavors, where in one can load the inverted version of the source register in to destination register. When CF or ZF are stored same value is replicated on all the 64bits.

//Loads ACCMULATOR or Carry Flag or Zero Flag in to any of the mentioned generic registers Reg0 to 16 registers. In case of CF and ZF same value is replicated on all the 64 bits.

- STORE <R0.. R15>, <ACCU, CF, ZF>

// Loads inverted (ACCMULATOR or Carry Flag or Zero Flag) in to any of the mentioned generic registers Reg0 to 15 registers

- STOREINV <R0.. R15>, <ACCU, CF, ZF> // Loads inverted (ACCMULATOR or Carry Flag or Zero Flag) in to any of the mentioned generic registers R0 to R15 registers

31	20	19	10	9	0
Opcode		Operand1		Operand2	
STORE		R0,R1..R15		ACCU/ZF/CF	
STOREINV		R0, R1.. R15		ACCU/ZF/CF	

Summary for ALU

Total Opcodes Supported: 12

Total Addressable Registers as source or destination: 21

- 16 GPR (R0, R1 ...R15)
- 1 ACCU
- 1ZF
- 1CF
- SRCA , SRCB



Summary of Instructions Supported

31	20	19	10	9	0
Opcode		Operand1		Operand2	
LOAD		SRCA/SRCB		REG0..REG15	
LOADINV		SRCA/SRCB		REG0..REG15	
LOAD0		SRCA/SRCB		N/A	
LOAD1		SRCA/SRCB		N/A	
ADD		N/A		N/A	
SUB		N/A		N/A	
AND		N/A		N/A	
OR		N/A		N/A	
XOR		N/A		N/A	
NOOP		N/A		N/A	
STORE		REG0..REG15		ACCU/CF/ZF	
STOREINV		REG0..REG15		ACCU/CF/ZF	



Table for ALU OPCODE Encodings

ALU OPCODE	OPCODE ENCODING
NOOP	0x000
LOAD	0x080
LOADINV	0x480
LOAD0	0x081
LOAD1	0x481
ADD	0x100
SUB	0x101
AND	0x102
OR	0x103
XOR	0x104
STORE	0x180
STOREINV	0x580

In the above mentioned table ALU Opcode Encodings look like some random numbers, rational behind those encodings is because of ALU Opcode is further broken down in to sub sections for ease of design implementation.

PREFIX		OPCODE		SUBOPCODE	
11	10	9	7	6	0
PREFIX VALUE		Description			
0		Regular			
1		Invert			
OPCODE VALUE		Description			
0		NOOP			
1		LOAD			
2		ALU			
3		STORE			



ALU OPCODE	ENCODING	PREFIX	OPCODE		SUBOPCODE	
			9	7	6	0
			10			
NOOP	0x000	0	0		0	
LOAD	0x080	0	1		0	
LOADINV	0x480	1	1		0	
LOAD0	0x081	0	1		1	
LOAD1	0x481	1	1		1	
ADD	0x100	0	2		0	
SUB	0x101	0	2		1	
AND	0x102	0	2		2	
OR	0x103	0	2		3	
XOR	0x104	0	2		4	
STORE	0x180	0	3		0	
STOREINV	0x580	1	3		0	

Table for Register Encodings

Register	Register Encoding
R0	0x0
R1	0x1
R2	0x2
R3	0x3
R4	0x4
R5	0x5
R6	0x6
R7	0x7
R8	0x8
R9	0x9



Register	Register Encoding
R10	0xa
R11	0xb
R12	0xc
R13	0xd
R14	0xe
R15	0xf
SRCA	0x20
SRCB	0x21
ACCU	0x31
ZF	0x32
CF	0x33

CS_GPR - Command Streamer General Purpose Registers

Following are Command Streamer General Purpose Registers:

CS_GPR - CS General Purpose Register



Memory Interface Commands for Rendering Engine

MI_SET_CONTEXT

MI_TOPOLOGY_FILTER]

MI_PREDICATE



Predicated Rendering Support in HW

Project:

DX10 defines predicated rendering, where sequences of rendering commands can be discarded based on the result of a previous predicate test. A new state bit, Predicate, has been added to the command stream. In addition, a PredicateEnable bit is added to 3DPRIMITIVE. When the PredicateEnable bit is set, the command is ignored if the Predicate state bit is set.

A new command, MI_PREDICATE, is added. It contains several control fields which specify how the Predicate bit is generated.

Refer to the diagram below and the command description (linked above) for details.

MI_PREDICATE Function

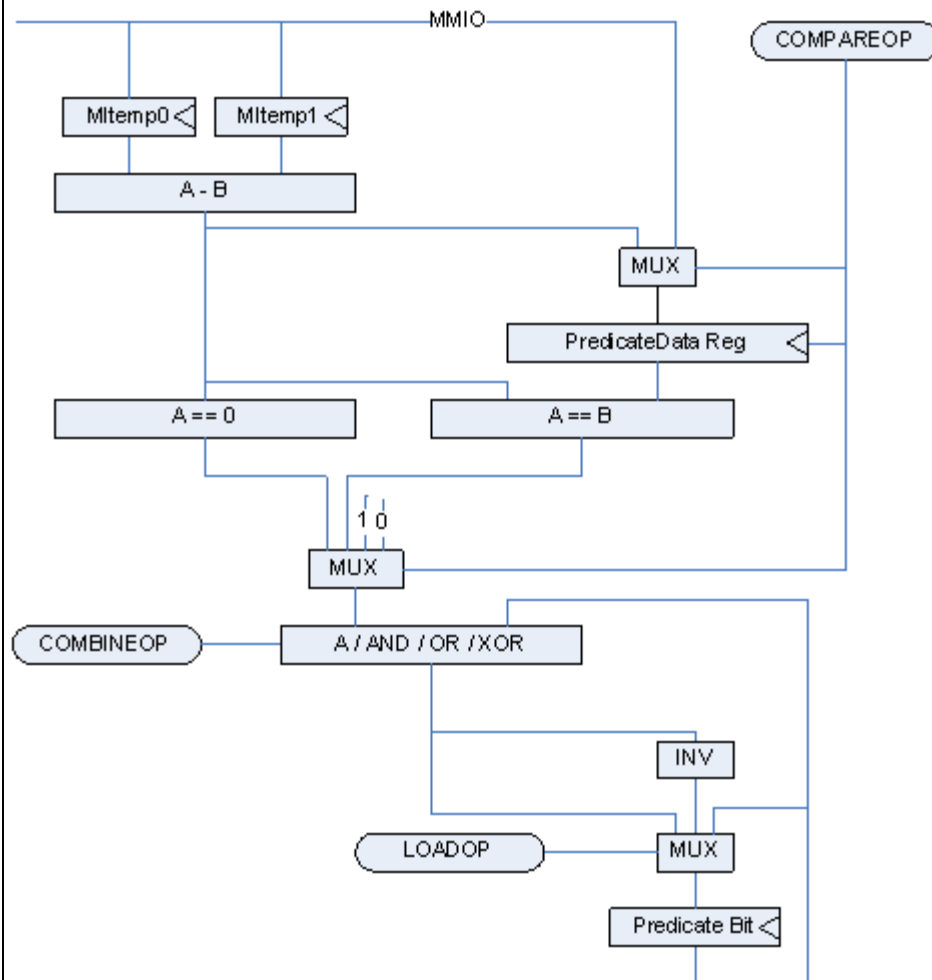

MI_LOAD_REGISTER_MEM commands can be used to load the Mtemp0, Mtemp1, and PredicateData registers prior to MI_PREDICATE. To ensure the memory sources of the MI_LOAD_REGISTER_MEM commands are coherent with previous 3D_PIPECONTROL store-DWord operations, software can use the new **Pipe Control Flush Enable** bit in the PIPE_CONTROL command.



MI_SET_PREDICATE

Programming Note: Below is a table of command(s) that can be disabled by the MI_SET_PREDICATE command:

Command	Project
3DSTATE_URB_VS	
3DSTATE_URB_HS	
3DSTATE_URB_DS	
3DSTATE_URB_GS	
3DSTATE_PUSH_CONSTANT_ALLOC_VS	
3DSTATE_PUSH_CONSTANT_ALLOC_HS	
3DSTATE_PUSH_CONSTANT_ALLOC_DS	
3DSTATE_PUSH_CONSTANT_ALLOC_GS	
3DSTATE_PUSH_CONSTANT_ALLOC_PS	
MI_LOAD_REGISTER_IMM	
MEDIA_VFE_STATE	
MEDIA_OBJECT	
MEDIA_OBJECT_WALKER	
MEDIA_INTERFACE_DESCRIPTOR_LOAD	

MI_SET_PREDICATE

MI_URB_CLEAR

MI_URB_ATOMIC_ALLOC

MI_LOAD_URB_MEM

MI_STORE_URB_MEM



State Commands

This section covers the following commands:

- **STATE_PREFETCH command.** The STATE_PREFETCH command is provided strictly as an optional mechanism to possibly enhance pipeline performance by prefetching data into the GPE's Instruction and State Cache (ISC).
- **STATE_SIP command**

STATE_PREFETCH

STATE_SIP

STATE_BASE_ADDRESS

The STATE_BASE_ADDRESS command sets the base pointers for subsequent state, instruction, and media indirect object accesses by the GPE. (See [Memory Access Indirection](#) for details.)

Programming Notes:

The following commands must be reissued following any change to the base addresses:

- 3DSTATE_PIPELINE_POINTERS
- 3DSTATE_BINDING_TABLE_POINTERS
- MEDIA_STATE_POINTERS

Execution of this command causes a full pipeline flush, thus its use should be minimized for higher performance.

STATE_BASE_ADDRESS

PIPELINE_SELECT

The **Pipeline Select** state is contained within the logical context.



Synchronization of the 3D Pipeline

Two types of synchronizations are supported for the 3D pipe: top of the pipe and end of the pipe. Top of the pipe synchronization really enforces the read-only cache invalidation. This synchronization guarantees that primitives rendered after such synchronization event fetches the latest read-only data from memory. End of the pipe synchronization enforces that the read and/or read-write buffers do not have outstanding hardware accesses. These are used to implement read and write fences as well as to write out certain statistics deterministically with respect to progress of primitives through the pipeline (and without requiring the pipeline to be flushed.) The PIPE_CONTROL command (see details below) is used to perform all of above synchronizations.

Top-of-Pipe Synchronization

Top-of-pipe synchronization refers to SW actions to prepare HW for new state-binding at the beginning of the rendering sequence in a given context. HW may have residual states cached in the state-caches and read-only surfaces in various caches. With new rendering sequence, read-only surfaces may go through change in the binding. Hence read-only invalidation is required before such new rendering sequence. Read-only cache invalidation is top-of-pipe synchronization. Upon parsing this specific pipe-control command, HW invalidates all caches in GT domain that have read-only surfaces but does not guarantee invalidation beyond GT caches (i.e. LLC). Further, HW does not guarantee that all prior accesses to those read-only surfaces have completed. Therefore SW must guarantee that there are no pending accesses to those read-only surfaces before initializing the top-of-pipe synchronization. PIPE_CONTROL command described below allows for invalidating individual read-only stream type. It is recommended that driver invalidates only the required caches on the need basis so that cache warm-up overhead can be reduced.

End-of-Pipe Synchronization

The driver can use end-of-pipe synchronization to know that rendering is complete (although not necessarily in memory) so that it can deallocate in-memory rendering state, read-only surfaces, instructions, and constant buffers. An end-of-pipe synchronization point is also sufficient to guarantee that all pending depth tests have completed so that the visible pixel count is complete prior to storing it to memory. End-of-pipe completion is sufficient (although not necessary) to guarantee that read events are complete (a "read fence" completion). Read events are still pending if work in the pipeline requires any type of read except a render target read (blend) to complete.

Write synchronization is a special case of end-of-pipe synchronization that requires that the render cache and/or depth related caches are flushed to memory, where the data will become globally visible. This type of synchronization is required prior to SW (CPU) actually reading the result data from memory, or initiating an operation that will use as a read surface (such as a texture surface) a previous render target and/or depth/stencil buffer. Exercising the write cache flush bits (Render Target Cache Flush Enable, Depth Cache Flush Enable, DC Flush) in PIPE_CONTROL only ensures the write caches are flushed and doesn't guarantee the data is globally visible.



SW can track the completion of the end-of-pipe-synchronization by using "Notify Enable" and "Post-Sync Operation - Write Immediate Data" in the PIPE_CONTROL command. "Notify Enable" and "Post-Sync Operation - Write Immediate Data" generate a fence cycle on achieving end-of-pipe-synchronization for the corresponding PIPE_CONTROL command. Fence cycle ensures all the write cycles in front of it are to global visible point before they themselves get processed. It is guaranteed the data flushed out by the PIPE_CONTROL is updated in memory by the time SW receives the corresponding Pipe Control Notify interrupt.

In case the data flushed out by the render engine is to be read back in to the render engine in coherent manner, then the render engine has to wait for the fence completion before accessing the flushed data. This can be achieved by following means on various products:

Project:	HSW
<p>Option 1:</p> <p>PIPE_CONTROL command with the CS Stall and the required write caches flushed with Post-Sync-Operation as Write Immediate Data followed by eight dummy MI_STORE_DATA_IMM (write to scratch spce) commands.</p> <p>Example:</p> <ul style="list-style-type: none">• Workload-1• PIPE_CONTROL (CS Stall, Post-Sync-Operation Write Immediate Data, Required Write Cache Flush bits set)• MI_STORE_DATA_IMM (8 times) (Dummy data, Scratch Address)• Workload-2 (Can use the data produce or output by Workload-1) <p>Option 2: This option has the overhead of TLBs getting invalidated.</p> <p>PIPE_CONTROL command with the TLB Invalidate, CS Stall, and the required write caches flushed with Post-Sync-Operation as Write Immediate Data.</p> <p>Example:</p> <ul style="list-style-type: none">• Workload-1 (3D/GPGPU/MEDIA)• PIPE_CONTROL (TLB Invalidate, CS Stall, Post-Sync-Operation Write Immediate Data, Required Write Cache Flush bits set)• WorkLoad-2 (Can use the data produce or output by Workload-1)	

Synchronization Actions

In order for the driver to act based on a synchronization point (usually the whole point), the reaching of the synchronization point must be communicated to the driver. This section describes the actions that may be taken upon completion of a synchronization point which can achieve this communication.



Writing a Value to Memory

The most common action to perform upon reaching a synchronization point is to write a value out to memory. An immediate value (included with the synchronization command) may be written. In lieu of an immediate value, the 64-bit value of the PS_DEPTH_COUNT (visible pixel count) or TIMESTAMP register may be written out to memory. The captured value will be the value at the moment all primitives parsed prior to the synchronization commands have been completely rendered, and optionally after all said primitives have been pushed to memory. It is not required that a value be written to memory by the synchronization command.

Visible pixel or TIMESTAMP information is only useful as a delta between 2 values, because these counters are free-running and are not to be reset except at initialization. To obtain the delta, two PIPE_CONTROL commands should be initiated with the command sequence to be measured between them. The resulting pair of values in memory can then be subtracted to obtain a meaningful statistic about the command sequence.

PS_DEPTH_COUNT

If the selected operation is to write the visible pixel count (PS_DEPTH_COUNT register), the synchronization command should include the **Depth Stall Enable** parameter. There is more than one point at which the global visible pixel count can be affected by the pipeline; once the synchronization command reaches the first point at which the count can be affected, any primitives following it are stalled at that point in the pipeline. This prevents the subsequent primitives from affecting the visible pixel count until all primitives preceding the synchronization point reach the end of the pipeline, the visible pixel count is accurate and the synchronization is completed. This stall has a minor effect on performance and should only be used in order to obtain accurate "visible pixel" counts for a sequence of primitives.

The PS_DEPTH_COUNT count can be used to implement an (API/DDI) "Occlusion Query" function.

Generating an Interrupt

The synchronization command may indicate that a "Sync Completion" interrupt is to be generated (if enabled by the MI Interrupt Control Registers – see *Memory Interface Registers*) once the rendering of all prior primitives is complete. Again, the completion of rendering can be considered to be when the internal render cache has been updated, or when the cache contents are visible in memory, as selected by the command options.

Invalidating of Caches

If software wishes to use the notification that a synchronization point has been reached in order to reuse referenced structures (surfaces, state, or instructions), it is not sufficient just to make sure rendering is complete. If additional primitives are initiated after new data is laid over the top of old in memory following a synchronization point, it is possible that stale cached data will be referenced for the subsequent rendering operation. In order to avoid this, the PIPE_CONTROL command must be used. (See PIPE_CONTROL Command description).



PIPE_CONTROL Command

The PIPE_CONTROL command is used to effect the synchronization described above. Parsing a PIPE_CONTROL command stalls the 3D pipe only if the stall enable bit is set. Commands after PIPE_CONTROL will continue to be parsed and processed in the 3D pipeline. This may include additional PIPE_CONTROL commands. The implementation does enforce a practical upper limit (8) on the number of PIPE_CONTROL commands that may be outstanding at once. Parsing a PIPE_CONTROL command that causes this limit to be reached will stall the parsing of new commands until the first of the outstanding PIPE_CONTROL commands reaches the end of the pipe and retires.

Note that although PIPE_CONTROL is intended for use with the 3D pipe, it is legal to issue PIPE_CONTROL when the Media pipe is selected. In this case PIPE_CONTROL will stall at the top of the pipe until the Media FFs finish processing commands parsed before PIPE_CONTROL. Post-synchronization operations, flushing of caches and interrupts will then occur if enabled via PIPE_CONTROL parameters. Due to this stalling behavior, only one PIPE_CONTROL command can be outstanding at a time on the Media pipe.

For the invalidate operation of the pipe control, the following pointers are affected. The invalidate operation affects the restore of these packets. If the pipe control invalidate operation is completed before the context save, the indirect pointers will not be restored from memory.

- Pipeline State Pointer
- Media State Pointer
- Constant Buffer Packet

It is up to software to program the appropriate read-only cache invalidation such as the sampler and constant read caches or the instruction and state caches. Once notification is observed, new data may then be loaded (potentially "on top of" the old data) without fear of stale cache data being referenced for subsequent rendering.

If software wishes to access the rendered data in memory (for analysis by the application or to copy it to a new location to use as a texture, for example), it must also ensure that the write cache (render cache) is flushed after the synchronization point is reached so that memory will be updated. This can be done by setting the **Write Cache Flush Enable** bit. Note that the **Depth Stall Enable** bit must be clear in order for the flush of the render cache to occur. **Depth Stall Enable** is intended only for accurate reporting of the PS_DEPTH counter; the render cache cannot be flushed nor can the read caches be invalidated (except for the instruction/state cache) in conjunction with this operation.

Vertex caches are only invalidated when the VF invalidate bit is set in PIPE_CONTROL (i.e. decision is done in software, not hardware) Note that the index-based vertex cache is always flushed between primitive topologies and of course PIPE_CONTROL can only be issued between primitive topologies. Therefore only the VF ("address-based") cache is uniquely affected by PIPE_CONTROL.



PIPE_CONTROL

Project	Description
HSW	Hardware supports up to 16 pending PIPE_CONTROL flushes.

Project	Security	Description
HSW		PIPECONTROL with RO Cache Invalidation: Prior to programming a PIPECONTROL command with any of the RO cache invalidation bit set program a PIPECONTROL flush command with "CS stall" bit and "HDC Flush" bit set.

The table below explains all the different flush/invalidation scenerios.

Caches Invalidated/Flushed by PIPE_CONTROL Bit Settings

Write Cache Flush	Notification Enabled	Non-VF RO Cache Invalidate	VF RO Cache Invalidate	Marker Sent	Pipeline Marker Enable	Completion Requested	Top of Pipe Invalidate Pulse from CS
0	0	0	0	N/A	N/A	N/A	N/A
0	0	0	1	Yes	No	N/A	No
0	0	1	0	No	N/A	N/A	Yes
0	0	1	1	Yes	No	No	Yes
X	1	0	X	Yes	Yes	Yes	No
X	1	1	X	Yes	Yes	Yes	Yes
1	X	0	X	Yes	Yes	Yes	No
1	X	1	X	Yes	Yes	Yes	Yes

PIPE_CONTROL

Programming Restrictions for PIPE_CONTROL

PIPE_CONTROL arguments can be split up into three categories:

- Post-sync operations
- Flush Types
- Stall

Post-sync operation is only indirectly affected by the flush type category via the stall bit. The stall category depends on the both flush type and post-sync operation arguments. A PIPE_CONTROL with no arguments set is **Invalid**.



Post-Sync Operation

These arguments relate to events that occur after the marker initiated by the PIPE_CONTROL command is completed. The table below shows the restrictions:

Argument	Bits	Restriction	Project	Security
LRI Post Sync Operation	23	Post Sync Operation ([15:14] of DW1) must be set to 0x0.		
Global Snapshot Count Reset	19	Requires stall bit ([20] of DW1) set.		
Generic Media State Clear	16	Requires stall bit ([20] of DW1) set.		
Indirect State Pointers Disable	9	Requires stall bit ([20] of DW1) set.		
Store Data Index	21	Post-Sync Operation ([15:14] of DW1) must be set to something other than '0'.		
Sync GFDT	17	Post-Sync Operation ([15:14] of DW1) must be set to something other than '0' or 0x2520[13] must be set.		
TLB inv	18	{All SKUs}{All Steppings}: Post-Sync Operation ([15:14] of DW1) must be set to something other than '0'.		
TLB inv	18	Requires stall bit ([20] of DW1) set.		
Post Sync Op	15:14	LRI Post Sync Operation ([23] of DW1) must be set to '0'.		

Flush Types

These are arguments related to the type of read only invalidation or write cache flushing is being requested. Note that there is only intra-dependency. That is, it is not affected by the post-sync operation or the stall bit. The table below shows the restrictions:

Arguments	Bit	Restrictions	Project
Depth Stall	13	No Restriction.	
Render Target Cache Flush	12	No Restriction.	
Depth Cache Flush	0	No Restriction.	
Stall Pixel Scoreboard	1	No Restriction.	
Inst invalidate	11	No Restriction.	
Tex invalidate	10	No Restriction.	
VF invalidate	4	No Restriction.	
Constant invalidate	3	No Restriction.	
State Invalidate	2	No Restriction.	



Stall

If the stall bit is set, the command streamer waits until the pipe is completely flushed.

Arguments	Bit	Restrictions	Project
Stall Bit	20	[All Stepping][All SKUs]: One of the following must also be set: <ul style="list-style-type: none">• Render Target Cache Flush Enable ([12] of DW1)• Depth Cache Flush Enable ([0] of DW1)• Stall at Pixel Scoreboard ([1] of DW1)• Depth Stall ([13] of DW1)• Post-Sync Operation ([13] of DW1)	



Render Logical Context Data

Logical Contexts are memory images used to store copies of the device's rendering and ring context.

Logical Contexts are aligned to 256-byte boundaries.

Logical contexts are referenced by their memory address. The format and contents of rendering contexts are considered *device-dependent* and software must not access the memory contents directly. The definition of the logical rendering and power context memory formats is included here primarily for internal documentation purposes.



Overall Context Layout

Context Layout

Entire context image consists of the *Register/State Context*, including the pipelined state section.



RegisterState Context

Context Color Codes Used

POWER CONTEXT
RING CONTEXT
MAIN CONTEXT
EXTENDED CONTEXT
URB_ATOMIC CONTEXT

Register Information

Register	Address	Unit	# of DW	Security
NOOP		CS	1	
Load_Register_Immediate header	0x1100_1083	CS	1	
RING_BUFFER_START	0x2038	CS	2	
RING_BUFFER_CONTROL	0x203C	CS	2	
RVSYNC	0x2040	CS	2	
RBSYNC	0x2044	CS	2	
RC_PSMI_CONTROL	0x2050	CS	2	
RC_PWRCTX_MAXCNT	0x2054	CS	2	
CTX_WA_PTR	0x2058	CS	2	
NOPID	0x2094	CS	2	
HWSTAM	0x2098	CS	2	
FF_THREAD_MODE	0x20A0	CS	2	
IMR	0x20A8	CS	2	
EIR	0x20B0	CS	2	
EMR	0x20B4	CS	2	
CMD_CCTL_0	0x20C4	CS	2	
GAFS_Mode	0x212C	CS	2	
UHPTR	0x2134	CS	2	
BB_PREEMPT_ADDR	0x2148	CS	2	
RING_BUFFER_HEAD_PREEMPT_REG	0x214C	CS	2	
CXT_SIZE	0x21A8	CS	2	
CXT_OFFSET	0x21AC	CS	2	
CXT_PIPESTATEBASE	0x21B0	CS	2	
PREEMPT_DLY	0x2214	CS	2	
GFX_MODE	0x229C	CS	2	
MTCH_CID_RST	0x222C	CS	2	
RLCONTENT00L	0x2250	CS	2	
RLCONTENT00H	0x2254	CS	2	



Register	Address	Unit	# of DW	Security
RLCONTENT01L	0x2258	CS	2	
RLCONTENT01H	0x225C	CS	2	
RLCONTENT02L	0x2260	CS	2	
RLCONTENT02H	0x2264	CS	2	
RLCONTENT03L	0x2268	CS	2	
RLCONTENT03H	0x226C	CS	2	
RLCONTENT10L	0x2270	CS	2	
RLCONTENT10H	0x2274	CS	2	
RLCONTENT11L	0x2278	CS	2	
RLCONTENT11H	0x227C	CS	2	
RLCONTENT12L	0x2280	CS	2	
RLCONTENT12H	0x2284	CS	2	
RLCONTENT13L	0x2288	CS	2	
RLCONTENT13H	0x228C	CS	2	
SYNC_FLIP_STATUS	0x22D0	CS	2	
SYNC_FLIP_STATUS_1	0x22D4	CS	2	
OSBUFFER	0x23B0	CS	2	
WAIT_FOR_RC6_EXIT	0x20CC	CS	2	
SECOND_BB_ADDR	0x2114	CS	2	
SECOND_BB_STATE	0x2118	CS	2	
RVESYNC	0x2048	CS	2	
SEMAPHORE-1/2	0x2680	CS	4	
RS_OFFSET	0x21B4	CS	2	
RS_PREEMPTION_HINT	0x24C0	CS	2	
CS_PREEMPTION_HINT	0x24BC	CS	2	
CCID Register	0x2180	CS	2	
SBB_PREEMPT_ADDRESS	0x213C	CS	2	
URB_CTX_OFFSET	0x21B8	CS	2	
NOOP		CS	10	
NOOP		GPM	1	
Load_Register_Immediate header	0x1100_108D	GPM	1	
GPM Data(Inc GAM)		GPM	142	
NOOP		GPM	1	
Load_Register_Immediate header	0x1100_1051	GPM	1	
MBCunit		GPM	82	
NOOP		GPM	1	
Load_Register_Immediate header	0x1100_1013	GPM	1	
GCPunit		GPM	20	
NOOP		GPM	1	



Register	Address	Unit	# of DW	Security
Load_Register_Immediate header	0x1100_101F	GPM	1	
GDTunit		GPM	32	
NOOP		GPM	1	
Load_Register_Immediate header	0x1100_1047	GPM	1	
GAMunit		GPM	72	
NOOP		GPM	106	
NOOP		SPM	1	
Load_Register_Immediate header	0x1100_1059	SPM	1	
SPMunit		SPM	90	
NOOP		SPM	4	
NOOP		CS	1	
Load_Register_Immediate header	0x1100_1015	CS	1	
Context Control	0x2244	CS	2	
Ring Head Pointer Register	0x2034	CS	2	
Ring Tail Pointer Register	0x2030	CS	2	
Batch Buffer Current Head Register	0x2140	CS	2	
Batch Buffer State Register	0x2110	CS	2	
PPGTT Directory Cache Valid Register	0x2220	CS	2	
PP_DIR_BASE	0x2228	CS	2	
Read Offset in Pipelined State Page (8 CL aligned)	0x224C	CS	2	
Committed Vertex Number	0x21C4	CS	2	
Committed Instance ID	0x21C8	CS	2	
Committed Primitive ID	0x21CC	CS	2	
NOOP		CS	8	
NOOP		CS	1	
Load_Register_Immediate header	0x1100_10BF	CS	1	
EXCC	0x2028	CS	2	
MI_MODE	0x209C	CS	2	
INSTPM	0x20C0	CS	2	
PR_CTR_CTL	0x2178	CS	2	
PR_CTR_THRSH	0x217C	CS	2	
IA_VERTICES_COUNT	0x2310	CS	4	
IA_PRIMITIVES_COUNT	0x2318	CS	4	
VS_INVOCATION_COUNT	0x2320	CS	4	
HS_INVOCATION_COUNT	0x2300	CS	4	
DS_INVOCATION_COUNT	0x2308	CS	4	
GS_INVOCATION_COUNT	0x2328	CS	4	
GS_PRIMITIVES_COUNT	0x2330	CS	4	
CL_INVOCATION_COUNT	0x2338	CS	4	



Register	Address	Unit	# of DW	Security
CL_PRIMITIVES_COUNT	0x2340	CS	4	
PS_INVOCATION_COUNT_0	0x22C8	CS	4	
PS_DEPTH_COUNT_0	0x22D8	CS	4	
VFSKPD	0x2470	CS	2	
TIMESTAMP Register (LSB)	0x2358	CS	2	
GPUGPU_DISPATCHDIMX	0x2500	CS	2	
GPUGPU_DISPATCHDIMY	0x2504	CS	2	
GPUGPU_DISPATCHDIMZ	0x2508	CS	2	
MI_PREDICATE_SRC0	0x2400	CS	2	
MI_PREDICATE_SRC0	0x2404	CS	2	
MI_PREDICATE_SRC1	0x2408	CS	2	
MI_PREDICATE_SRC1	0x240C	CS	2	
MI_PREDICATE_DATA	0x2410	CS	2	
MI_PREDICATE_DATA	0x2414	CS	2	
MI_PRED_RESULT	0x2418	CS	2	
3DPRIM_END_OFFSET	0x2420	CS	2	
3DPRIM_START_VERTEX	0x2430	CS	2	
3DPRIM_VERTEX_COUNT	0x2434	CS	2	
3DPRIM_INSTANCE_COUNT	0x2438	CS	2	
3DPRIM_START_INSTANCE	0x243C	CS	2	
3DPRIM_BASE_VERTEX	0x2440	CS	2	
GPGPU_THREADS_DISPATCHED	0x2290	CS	4	
PS_INVOCATION_COUNT_1	0x22F0	CS	4	
PS_DEPTH_COUNT_1	0x22F8	CS	4	
BB_START_ADDR	0x2150	CS	2	
BB_ADD_DIFF	0x2154	CS	2	
BB_OFFSET	0x2158	CS	2	
RS_PREEMPT_STATUS	0x215C	CS	2	
CTX_SEMA_REG	0x24B4	CS	4	
PRODUCE_COUNT_BTP	0x2480	CS	2	
PRODUCE_COUNT_DX9_CONSTANTS	0x2484	CS	2	
PRODUCE_COUNT_GATHER_CONSTANTS	0x248C	CS	2	
PARSED_COUNT_BTP	0x2490	CS	2	
PARSED_COUNT_DX9_CONSTANTS	0x2494	CS	2	
MI_PREDICATE_RESULT_1	0x241C	CS	2	
CS_GPR (1-16)	0x2600	CS	64	
MI_TOPOLOGY_FILTER		CS	1	
MI_URB_CLEAR		CS	2	
MI_SET_APPID		CS	1	



Register	Address	Unit	# of DW	Security
PIPELINE_SELECT		CS	1	
STATE_BASE_ADDRESS		CS	12	
3DSTATE_PUSH_CONSTANT_ALLOC_VS		CS	2	
3DSTATE_PUSH_CONSTANT_ALLOC_HS		CS	2	
3DSTATE_PUSH_CONSTANT_ALLOC_DS		CS	2	
3DSTATE_PUSH_CONSTANT_ALLOC_GS		CS	2	
3DSTATE_PUSH_CONSTANT_ALLOC_PS		CS	2	
3DSTATE_BINDING_TABLE_POOL_ALLOC		CS	3	
3DSTATE_GATHER_POOL_ALLOC		CS	3	
3DSTATE_DX9_CONSTANT_BUFFER_POOL_ALLOC		CS	3	
MI_RS_CONTROL		CS	1	
MI_URB_ATOMIC_ALLOC		CS	1	
NOOP		CS	8	
NOOP		SARB	1	
Load_Register_Immediate header	0x1100_10CF	SARB	1	
SARB Data		SARB	208	
NOOP		SARB	14	
3DSTATE_VS		SVG	6	
3DSTATE_BINDING_TABLE_POINTERS_VS		SVG	2	
3DSTATE_SAMPLER_STATE_POINTERS_VS		SVG	2	
3DSTATE_CONSTANT_VS		SVG	7	
3DSTATE_URB_VS		SVG	2	
3DSTATE_HS		SVG	7	
3DSTATE_BINDING_TABLE_POINTERS_HS		SVG	2	
3DSTATE_SAMPLER_STATE_POINTERS_HS		SVG	2	
3DSTATE_CONSTANT_HS		SVG	7	
3DSTATE_URB_HS		SVG	2	
3DSTATE_TE		SVG	4	
3DSTATE_DS		SVG	6	
3DSTATE_BINDING_TABLE_POINTERS_DS		SVG	2	
3DSTATE_SAMPLER_STATE_POINTERS_DS		SVG	2	
3DSTATE_CONSTANT_DS		SVG	7	
3DSTATE_URB_DS		SVG	2	
3DSTATE_GS		SVG	7	
3DSTATE_BINDING_TABLE_POINTERS_GS		SVG	2	
3DSTATE_SAMPLER_STATE_POINTERS_GS		SVG	2	
3DSTATE_CONSTANT_GS		SVG	7	
3DSTATE_URB_GS		SVG	2	
3DSTATE_STREAMOUT		SVG	3	



Register	Address	Unit	# of DW	Security
3DSTATE_CLIP		SVG	4	
3DSTATE_VIEWPORT_STATE_POINTERS_CL_SF		SVG	2	
3DSTATE_SF		SVG	7	
3DSTATE_SCISSOR_STATE_POINTERS		SVG	2	
3DSTATE_MULTISAMPLE		SVG	4	
3DSTATE_DRAWING_RECTANGLE		SVG	4	
SWTESS_BASE_ADDRESS		SVG	2	
NOOP		SVG	2	
3DSTATE_WM		SVL	3	
3DSTATE_VIEWPORT_STATE_POINTERS_CC		SVL	2	
3DSTATE_CC_STATE_POINTERS		SVL	2	
3DSTATE_DEPTHSTENCIL_STATE_POINTERS		SVL	2	
3DSTATE_SAMPLE_MASK		SVL	2	
3DSTATE_SBE		SVL	14	
3DSTATE_CONSTANT_PS		SVL	7	
3DSTATE_PS		SVL	8	
3DSTATE_BINDING_TABLE_POINTERS_PS		SVL	2	
3DSTATE_SAMPLER_STATE_POINTERS_PS		SVL	2	
3DSTATE_BLEND_STATE_POINTERS		SVL	2	
Load_Register_Immediate header	0x1100_1011	SVL	1	
Cache_Mode_0	0x7000	SVL	2	
Cache_Mode_1	0x7004	SVL	2	
GT_MODE	0x7008	SVL	2	
FBC_RT_BASE_ADDR_REGISTER	0x7020	SVL	2	
SAMPLER_MODE	0x7028	SVL	2	
STATE_SIP		SVL	2	
3DSTATE_DEPTH_BUFFER		SVL	7	
3DSTATE_STENCIL_BUFFER		SVL	3	
3DSTATE_HIER_DEPTH_BUFFER		SVL	3	
3DSTATE_CLEAR_PARAMS		SVL	3	
3DSTATE_RAST_MULTISAMPLE		SVL	6	
GPGPU_CSR_BASE_ADDRESS		SVL	2	
NOOP		SVL	5	
NOOP		TDL	1	
Load_Register_Immediate header	0x1100_1069	TDL	1	
TD_CTL	E400	TDL	2	
TD_CTL2	E404	TDL	2	
TD_VF_VS_EMSK	E408	TDL	2	
TD_GS_EMSK	E40C	TDL	2	



Register	Address	Unit	# of DW	Security
TD_WIZ_EMSK	E410	TDL	2	
TD_TS_EMSK	E428	TDL	2	
TD_HS_EMSK	E4B0	TDL	2	
TD_DS_EMSK	E4B4	TDL	2	
TD_CTL	E500	TDL	2	
TD_CTL2	E504	TDL	2	
TD_VF_VS_EMSK	E508	TDL	2	
TD_GS_EMSK	E50C	TDL	2	
TD_WIZ_EMSK	E510	TDL	2	
TD_TS_EMSK	E528	TDL	2	
TD_HS_EMSK	E5B0	TDL	2	
TD_DS_EMSK	E5B4	TDL	2	
TD_CTL	E600	TDL	2	
TD_CTL2	E604	TDL	2	
TD_VF_VS_EMSK	E608	TDL	2	
TD_GS_EMSK	E60C	TDL	2	
TD_WIZ_EMSK	E610	TDL	2	
TD_TS_EMSK	E628	TDL	2	
TD_HS_EMSK	E6B0	TDL	2	
TD_DS_EMSK	E6B4	TDL	2	
TD_CTL	E700	TDL	2	
TD_CTL2	E704	TDL	2	
TD_VF_VS_EMSK	E708	TDL	2	
TD_GS_EMSK	E70C	TDL	2	
TD_WIZ_EMSK	E710	TDL	2	
TD_TS_EMSK	E728	TDL	2	
TD_HS_EMSK	E7B0	TDL	2	
TD_DS_EMSK	E7B4	TDL	2	
NOOP		TDL	4	
NOOP		WM	1	
Load_Register_Immediate header	0x1100_1003	WM	1	
SuperSpan Count	0x5520	WM	2	
3DSTATE_POLY_STIPPLE_PATTERN		WM	33	
3DSTATE_AA_LINE_PARAMS		WM	3	
3DSTATE_POLY_STIPPLE_OFFSET		WM	2	
3DSTATE_LINE_STIPPLE		WM	3	
NOOP		WM	1	
NOOP		SC	1	
Load_Register_Immediate header	0x1100_1005	SC	1	



Register	Address	Unit	# of DW	Security
3DSTATE_MONOFILTER_SIZE		SC	2	
3DSTATE_CHROMA_KEY		SC	16	
NOOP		SC	6	
Load_Register_Immediate header	0x1100_105D	VFE	1	
TDL DATA		VFE	94	
NOOP		VFE	1	
Load_Register_Immediate header	0x1100_105D	VFE	1	
TDL DATA		VFE	94	
NOOP		VFE	1	
Load_Register_Immediate header	0x1100_105D	VFE	1	
TDL DATA		VFE	94	
NOOP		VFE	1	
Load_Register_Immediate header	0x1100_105D	VFE	1	
TDL DATA		VFE	94	
NOOP		VFE	1	
Load_Register_Immediate header	0x1100_1029	VFE	1	
GW DATA		VFE	42	
NOOP		VFE	5	
Load_Register_Immediate header	0x1100_1029	VFE	1	
GW DATA		VFE	42	
NOOP		VFE	5	
Load_Register_Immediate header	0x1100_1029	VFE	1	
GW DATA		VFE	42	
NOOP		VFE	5	
Load_Register_Immediate header	0x1100_1029	VFE	1	
GW DATA		VFE	42	
NOOP		VFE	5	
Load_Register_Immediate header	0x1100_1017	VFE	1	
TSG DATA		VFE	24	
NOOP		VFE	7	
Load_Register_Immediate header	0x1100_1017	VFE	1	
TSG DATA		VFE	24	
NOOP		VFE	7	
Load_Register_Immediate header	0x1100_1017	VFE	1	
TSG DATA		VFE	24	
NOOP		VFE	7	
Load_Register_Immediate header	0x1100_1017	VFE	1	
TSG DATA		VFE	24	
NOOP		VFE	7	



Register	Address	Unit	# of DW	Security
MEDIA_VFE_STATE		VFE	8	
MEDIA_CURBE_LOAD		VFE	4	
MEDIA_INTERFACE_DESCRIPTOR_LOAD		VFE	4	
MEDIA_OBJECT_PRT/GPGPU_WALKER		VFE	16	
MEDIA_STATE_FLUSH		VFE	2	
NOOP		VFE	14	
3DSTATE_SAMPLER_PALETTE_LOAD0		DM	257	
3DSTATE_SAMPLER_PALETTE_LOAD1		DM	257	
NOOP		DM	14	
NOOP		SOL	1	
Load_Register_Immediate header	0x1100_1027	SOL	1	
SO_NUM_PRIMS_WRITTEN0	0x5200	SOL	4	
SO_NUM_PRIMS_WRITTEN1	0x5208	SOL	4	
SO_NUM_PRIMS_WRITTEN2	0x5210	SOL	4	
SO_NUM_PRIMS_WRITTEN3	0x5218	SOL	4	
SO_PRIM_STORAGE_NEEDED0	0x5240	SOL	4	
SO_PRIM_STORAGE_NEEDED1	0x5248	SOL	4	
SO_PRIM_STORAGE_NEEDED2	0x5250	SOL	4	
SO_PRIM_STORAGE_NEEDED3	0x5258	SOL	4	
SO_WRITE_OFFSET0	0x5280	SOL	2	
SO_WRITE_OFFSET1	0x5284	SOL	2	
SO_WRITE_OFFSET2	0x5288	SOL	2	
SO_WRITE_OFFSET3	0x528C	SOL	2	
3DSTATE_SO_BUFFER		SOL	16	
NOOP		SOL	3	
3DSTATE_SO_DECL_LIST		SOL	259	
3DSTATE_INDEX_BUFFER		VF	3	
3DSTATE_VERTEX_BUFFERS		VF	133	
3DSTATE_VERTEX_ELEMENTS		VF	69	
3DSTATE_VF_STATISTICS		VF	1	
3DSTATE_VF		VF	2	
NOOP		RS	3	
3DSTATE_BINDING_TABLE_POOL_ALLOC		RS	3	
3DSTATE_BINDING_TABLE_EDIT_VS		RS	258	
NOOP		RS	6	
3DSTATE_BINDING_TABLE_EDIT_GS		RS	258	
NOOP		RS	6	
3DSTATE_BINDING_TABLE_EDIT_HS		RS	258	
NOOP		RS	6	



Register	Address	Unit	# of DW	Security
3DSTATE_BINDING_TABLE_EDIT_DS		RS	258	
NOOP		RS	6	
3DSTATE_BINDING_TABLE_EDIT_PS		RS	258	
3DSTATE_GATHER_POOL_ALLOC		RS	3	
MI_BATCH_BUFFER_END/NOOP ***		RS	1	
NOOP		RS	7	
3DSTATE_DX9_CONSTANT_BUFFER_POOL_ALLOC		RS	3	
3DSTATE_DX9_CONSTANTF_VS(Global)		RS	1026	
NOOP		RS	6	
3DSTATE_DX9_CONSTANTI_VS(Global)		RS	66	
NOOP		RS	6	
3DSTATE_DX9_CONSTANTB_VS(Global)		RS	18	
NOOP		RS	6	
3DSTATE_DX9_CONSTANTF_VS(local)		RS	1026	
NOOP		RS	6	
3DSTATE_DX9_CONSTANTI_VS(local)		RS	66	
NOOP		RS	6	
3DSTATE_DX9_CONSTANTB_VS(local)		RS	18	
NOOP		RS	4	
3DSTATE_DX9_LOCAL_VALID_VS		RS	10	
3DSTATE_DX9_CONSTANTF_PS(Global)		RS	1026	
NOOP		RS	6	
3DSTATE_DX9_CONSTANTI_PS(Global)		RS	66	
NOOP		RS	6	
3DSTATE_DX9_CONSTANTB_PS(Global)		RS	18	
NOOP		RS	6	
3DSTATE_DX9_CONSTANTF_PS(local)		RS	1026	
NOOP		RS	6	
3DSTATE_DX9_CONSTANTI_PS(local)		RS	66	
NOOP		RS	6	
3DSTATE_DX9_CONSTANTB_PS(local)		RS	18	
3DSTATE_DX9_LOCAL_VALID_PS		RS	10	
MI_BATCH_BUFFER_END		RS	1	
NOOP		RS	13	
URB_ATOMIC_STORAGE		GAFS	8192	



Command Ordering Rules

There are several restrictions regarding the ordering of commands issued to the GPE. This subsection describes these restrictions along with some explanation of why they exist. Refer to the various command descriptions for additional information.

The following flowchart illustrates *an example ordering* of commands which can be used to perform activity within the GPE.

Note: Common or Pipeline-specific state-setting commands can be issued along any paths from this point down

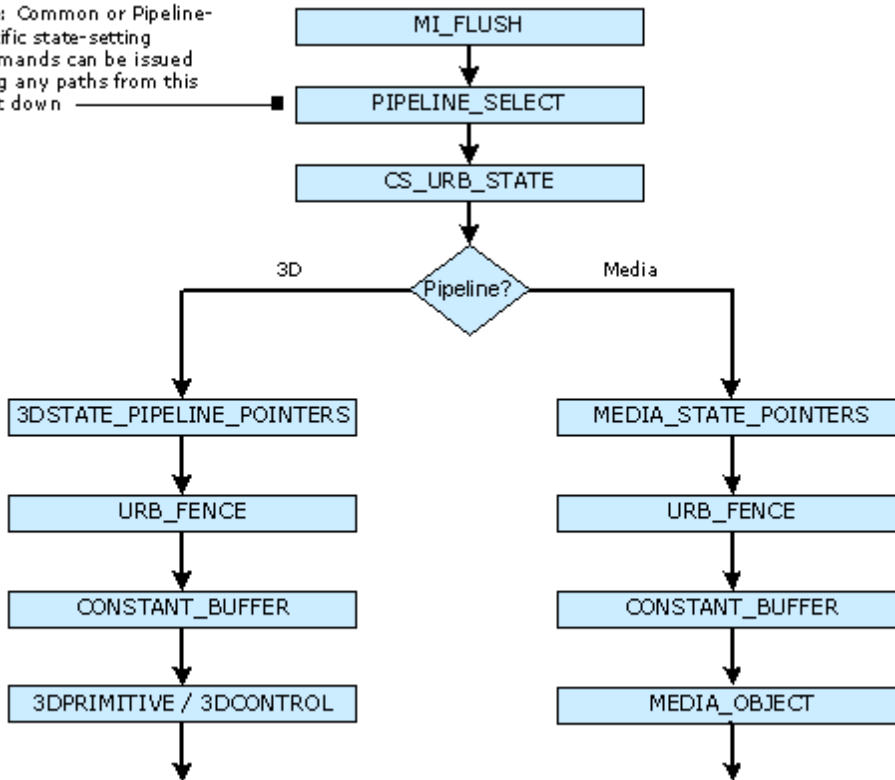

B 6680-01



PIPELINE_SELECT

The previously-active pipeline needs to be flushed via the MI_FLUSH command immediately before switching to a different pipeline via use of the PIPELINE_SELECT command. Refer to [Fixed and Shared Function IDs](#) for details on the PIPELINE_SELECT command.

PIPELINE_SELECT



PIPE_CONTROL

The PIPE_CONTROL command does not require URB fencing/allocation to have been performed, nor does it rely on any other pipeline state. It is intended to be used on both the 3D pipe and the Media pipe. It has special optimizations to support the pipelining capability in the 3D pipe which do not apply to the Media pipe.



URB-Related State-Setting Commands

Several commands are used (among other things) to set state variables used in URB entry allocation --- specifically, the **Number of URB Entries** and the **URB Entry Allocation Size** state variables associated with various pipeline units. These state variables must be set-up prior to the issuing of a URB_FENCE command. (See the subsection on URB_FENCE.)

CS_URB_STATE (only) specifies these state variables for the common CS FF unit.

3DSTATE_PIPELINED_POINTERS sets the state variables for FF units in the 3D Pipeline, and MEDIA_STATE_POINTERS sets them for the Media pipeline. Depending on which pipeline is currently active, only one of these commands needs to be used. Note that these commands can also be reissued at a later time to change other state variables, though if a change is made to (a) any **Number of URB Entries** and the **URB Entry Allocation Size** state variables or (b) the **Maximum Number of Threads** state for the GS or CLIP FF units, a URB_FENCE command must follow.



Common Pipeline State-Setting Commands

The following commands are used to set state common to both the 3D and Media pipelines. This state is comprised of CS FF unit state, non-pipelined global state (EU, etc.), and Sampler shared-function state.

- STATE_BASE_ADDRESS
- STATE_SIP
- 3DSTATE_SAMPLER_PALETTE_LOAD
- 3DSTATE_CHROMA_KEY

The state variables associated with these commands must be set appropriately prior to initiating activity within a pipeline (i.e., 3DPRIMITIVE or MEDIA_OBJECT).



3D Pipeline-Specific State-Setting Commands

The following commands are used to set state specific to the 3D Pipeline.

- 3DSTATE_PIPELINED_POINTERS
- 3DSTATE_BINDING_TABLE_POINTERS
- 3DSTATE_VERTEX_BUFFERS
- 3DSTATE_VERTEX_ELEMENTS
- 3DSTATE_INDEX_BUFFERS
- 3DSTATE_VF_STATISTICS
- 3DSTATE_DRAWING_RECTANGLE
- 3DSTATE_CONSTANT_COLOR
- 3DSTATE_DEPTH_BUFFER
- 3DSTATE_POLY_STIPPLE_OFFSET
- 3DSTATE_POLY_STIPPLE_PATTERN
- 3DSTATE_LINE_STIPPLE
- 3DSTATE_GLOBAL_DEPTH_OFFSET

The state variables associated with these commands must be set appropriately prior to issuing 3DPRIMITIVE.



Media Pipeline-Specific State-Setting Commands

The following command is used to set state specific to the Media pipeline:

- MEDIA_STATE_POINTERS

The state variables associated with this command must be set appropriately prior to issuing MEDIA_OBJECT.



3DPRIMITIVE

Before issuing a 3DPRIMITIVE command, all state (with the exception of MEDIA_STATE_POINTERS) needs to be valid. Thus the commands used to assigned that state must be issued before issuing 3DPRIMITIVE.



MEDIA_OBJECT

Before issuing a MEDIA_OBJECT command, all state (with the exception of 3D-pipeline-specific state) needs to be valid. Therefore the commands used to set this state need to have been issued at some point prior to the issue of MEDIA_OBJECT.



Resource Streamer

This section contains status registers and controls for the resource streamer.

RS_PREEMPT_STATUS - Resource Streamer Preemption Status

MI_RS_CONTEXT

MI_RS_CONTROL

MI_RS_STORE_DATA_IMM



Resource Streamer Sync Commands

Project:	HSW
If resource streamer is enabled in a batch buffer, an MI_RS_STORE_DATA_IMM with Resource Streamer Flush set must be programmed before any Resource Streamer Sync Command.	

Below is a table of commands that cause the resource streamer to stop and wait until the render command streamer restarts the resource streamer. If a command does not end the current batch buffer or disable the resource streamer, then the command streamer will restart the resource streamer before the next command that is used by the resource streamer.

Resource Streamer Sync Commands: Commands that RS Stops	Project
MI_WAIT_FOR_EVENT	
MI_RS_CONTROL	
MI_BATCH_BUFFER_END	
MI_SEMAPHORE_MBOX	
MI_SET_CONTEXT	
MI_RS_CONTEXT	
MI_BATCH_BUFFER_START	
MI_CONDITIONAL_BATCH_BUFFER_END	



Hardware Binding Tables

The driver spends a considerable amount of time managing the binding tables. A new command is added, `3DSTATE_BINDING_TABLE_EDIT_*`, to offload the binding table generation from the driver. There is an on-die set of binding tables for each FF (VS, GS, HS, DS, PS). The `3DSTATE_BINDING_TABLE_EDIT_*` commands are used by the driver to update these tables. The `3DSTATE_BINDING_TABLE_POINTER_*` commands are added. When the resource streamer encounters a `3DSTATE_BINDING_TABLE_POINTER_*` command, it writes the binding table out to the binding table pool. When the command streamer encounters a `3DSTATE_BINDING_TABLE_POINTER_*` command, it sends the binding table pointer down as pipelined state.

Project:	HSW
<p>Hardware Binding Tables are only supported for 3D workloads. The resource streamer must be enabled only for 3D workloads. The resource streamer must be disabled for Media and GPGPU workloads. A batch buffer containing both 3D and GPGPU workloads must take care of disabling and enabling the Resource Streamer appropriately while changing the PIPELINE_SELECT mode from 3D to GPGPU and vice versa. The resource streamer must be disabled using MI_RS_CONTROL command and Hardware Binding Tables must be disabled by programming 3DSTATE_BINDING_TABLE_POOL_ALLOC with "Binding Table Pool Enable" set to disable (i.e value '0'). The following example shows disabling and enabling of the resource streamer in a batch buffer for 3D and GPGPU workloads:</p> <pre>MI_BATCH_BUFFER_START (Resource Streamer Enabled) PIPELINE_SELECT (3D) 3DSTATE_BINDING_TABLE_POOL_ALLOC (Binding Table Pool Enabled) 3D WORKLOAD MI_RS_CONTROL (Disable Resource Streamer) 3DSTATE_BINDING_TABLE_POOL_ALLOC (Binding Table Pool Disabled) PIPELINE_SELECT (GPGPU) GPGPU Workload 3DSTATE_BINDING_TABLE_POOL_ALLOC (Binding Table Pool Enabled) MI_RS_CONTROL (Enable Resource Streamer) 3D WORKLOAD MI_BATCH_BUFFER_END</pre>	



3DSTATE_BINDING_TABLE_POOL_ALLOC

Project	Programming Note
	The binding table generator feature has a simple all or nothing model. If HW generated binding tables are enabled, the driver must enable the pool and use 3D_HW_BINDING_TABLE_POINTER_* commands.
	When switching between HW and SW binding table generation, SW must issue a state cache invalidate.
	A maximum of 16,383 Binding Tables are allowed in any batch buffer.
	If the Binding Table Pool Enable is cleared while the Resource Streamer is enabled within a batch buffer, then the on chip storage for the binding table will not be context save and restored. To save the Binding Table Pool, before disabling the Pool enable, disable the resource streamer thru the MI_RS_CONTROL command. And then, before re-enabling the Binding Table Pool, re-enable the resource streamer thru the MI_RS_CONTROL command.

Programming Note: These are variable length commands: 3DSTATE_BINDING_TABLE_EDIT_HS, 3DSTATE_BINDING_TABLE_EDIT_DS, and 3DSTATE_BINDING_TABLE_EDIT_PS.

3DSTATE_BINDING_TABLE_POOL_ALLOC

3DSTATE_BINDING_TABLE_EDIT_VS

3DSTATE_BINDING_TABLE_EDIT_HS

3DSTATE_BINDING_TABLE_EDIT_DS

3DSTATE_BINDING_TABLE_EDIT_GS

3DSTATE_BINDING_TABLE_EDIT_PS



Gather Constants

In Dx10 the app can provide up to 16 constant buffers. The compiler does some optimizations of constant usage and determines which elements of which constants should be packed in which push constant register for optimum shader performance. While this gathering and packing of constant elements into push constant registers optimizes the shader, it causes the driver added work at draw call time, because the driver must do the gather and packing at draw time. A new command, `3D_STATE_GATHER_CONSTANT_*`, is added to offload the gather and packing functions from the driver. There are 5 FF which support push constants (VS, GS, DS, HS, PS) and they all have corresponding gather commands. The compiler generates a gather table that specifies what elements of what buffers are packed into the gather buffer. The gather table indexes the BT to get the surface state which points to the constant buffer. The resource streamer fills the gather buffer when it executes a `3D_STATE_GATHER_CONSTANT_*` command. Once the gather buffer has been filled, the command streamer executes the `3D_STATE_CONSTANT_*` command to load the push constant into the URB.

Note: The gather push constants can only be used if the HW generated binding tables are also used.

Project:	HSW
Programming Note: If the surface type is NULL, any fetch using the surface state base address is not bound by the size of the surface state and the fetch still occurs.	

3DSTATE_GATHER_VS

Programming Note: The HW generated binding table must be enabled to use this command.

Project:	HSW
Programming Note: The constant buffer block (group of aligned 16 binding table entries) must be set before this command is issued.	

Programming Note: The length of the gather table is derived from the total length of the command. The command length is in DWords, but the gather table entries are 16 bits in length. If there is an unused odd entry at the end of the command the channel mask should be set to all 0s.

Programming Note: When a `3DSTATE_GATHER_CONSTANT_*` command is used there must be a matching `3DSTATE_CONSTANT_*`. Furthermore the `3DSTATE_CONSTANT_*` must occur in the same order as the `3DSTATE_GATHER_CONSTANT_*`. For example if a `3DSTATE_GATHER_CONSTANT_VS` occurs before a `3DSTATE_GATHER_CONSTANT_PS`, then the `3DSTATE_CONSTANT_VS` must occur before the `3DSTATE_CONSTANT_PS`.

Programming Note: If Gather pool is enabled, there must be a corresponding `3DSTATE_GATHER_CONSTANT` command with any `3DSTATE_CONSTANT` for any particular shader. To avoid any update to the Gather pool, and yet program the `3DSTATE_CONSTANT` for a particular shader, send a `3DSTATE_GATHER_CONSTANT` command with all valid bits set to zero. Gather Pool must be disabled if executing a `3DSTATE_CONSTANT` command unless the resource streamer is enabled to process a GATHER command (RS enabled batch and RS has not been disabled with a `MI_RS_CONTROL` command).



3DSTATE_GATHER_HS

Programming Note: The HW-generated binding table must be enabled to use this command.

Project:	HSW
Programming Note: Furthermore, the constant buffer block (group of aligned 16 binding table entries) must be set before this command is issued.	

Programming Note: The length of the gather table is derived from the total length of the command. The command length is in DWords, but the gather table entries are 16 bits in length. If there is an unused odd entry at the end of the command the channel mask should be set to all 0s.

Programming Note: When a 3DSTATE_GATHER_CONSTANT_* command is used there must be a matching 3DSTATE_CONSTANT_*. Furthermore the 3DSTATE_CONSTANT_* must occur in the same order as the 3DSTATE_GATHER_CONSTANT_*. In other words if a 3DSTATE_GATHER_CONSTANT_VS occurs before a 3DSTATE_GATHER_CONSTANT_PS, then the 3DSTATE_CONSTANT_VS must occur before the 3DSTATE_CONSTANT_PS.

Programming Note: If Gather pool is enabled, there must be a corresponding 3DSTATE_GATHER_CONSTANT command with any 3DSTATE_CONSTANT for any particular shader. If the programmer wants to avoid any update to the Gather pool, and yet program the 3DSTATE_CONSTANT for a particular shader, it can send a 3DSTATE_GATHER_CONSTANT command with all valid bits set to zero. Gather Pool must be disabled if executing a 3DSTATE_CONSTANT command unless the resource streamer is enabled to process a GATHER command (RS enabled batch and RS has not been disabled with a MI_RS_CONTROL command).

Project:	HSW
Programming Notes: The 3DSTATE_GATHER_* command is not committed to the resource streamer engine until the corresponding (same shader) 3DSTATE_BINDING_TABLE_POINTER_* command. For example, the 3DSTATE_GATHER_VS command does not actually generate a buffer in memory until the 3DSTATE_BINDING_TABLE_POINTERS_VS is parsed by the resource streamer.	
Note: The following commands must be executed <i>before</i> any 3DSTATE_GATHER_CONSTANT_* command that has Constant Buffer Valid equal to zero:	
<ul style="list-style-type: none"> • 3DPRIMITIVE – To ensure resource streamer initiates produce prior to next command: <ul style="list-style-type: none"> Indirect Parameter Enable = 0 UAV Coherency Required = 0 Predicate Enable = 0 End Offset Enable = 0 Vertex Access Type = SEQUENTIAL Primitive Topology Type = 3DPRIM_POINTLIST Vertex Count Per Instance = 0 Start Vertex Location = 0 Instance Count = 0 Start Instance Location = 0 Base Vertex Location = 0 • MI_RS_STORE_DATA_IMM – To force engine idle prior to executing next instruction. Write must 	



occur to address that does not corrupt memory:

```
Resource Streamer Flush = 1
```

Note: The following commands must be executed *before* any 3DSTATE_GATHER_CONSTANT_* command that has **Constant Buffer Valid** greater than zero:

- 3DPRIMITIVE – To ensure resource streamer initiates produce prior to next command:

```
Indirect Parameter Enable = 0
UAV Coherency Required    = 0
Predicate Enable          = 0
End Offset Enable         = 0
Vertex Access Type        = SEQUENTIAL
Primitive Topology Type   = 3DPRIM_POINTLIST
Vertex Count Per Instance = 0
Start Vertex Location     = 0
Instance Count            = 0
Start Instance Location   = 0
Base Vertex Location      = 0
```

Note: The following commands must be executed *following* any 3DSTATE_GATHER_CONSTANT_* command that has **Constant Buffer Valid** greater than zero:

- MI_RS_STORE_DATA_IMM – To force engine idle prior to executing next instruction. Write must occur to address that does not corrupt memory:
Resource Streamer Flush = 1
- MI_RS_STORE_DATA_IMM – To force all previous writes to coherent memory point. Write must occur to address that does not corrupt memory:
Resource Streamer Flush = 1
- 3DSTATE_GATHER_CONSTANT_PS – To ensure correct timing of sync between resource streamer and render pipeline:
Constant Buffer Valid = 0
- 3DSTATE_CONSTANT_PS:
Constant Buffer 1 Read Length = 0
Constant Buffer 0 Read Length = 0
Constant Buffer 3 Read Length = 0
Constant Buffer 2 Read Length = 0



3DSTATE_GATHER_DS

Programming Note: The HW generated binding table must be enabled to use this command.

Project:	HSW
Programming Note: The constant buffer block (group of aligned 16 binding table entries) must be set before this command is issued.	

Programming Note: The length of the gather table is derived from the total length of the command. The command length is in DWords, but the gather table entries are 16 bits in length. If there is an unused odd entry at the end of the command the channel mask should be set to all 0s.

Programming Note: When a 3DSTATE_GATHER_CONSTANT_* command is used there must be a matching 3DSTATE_CONSTANT_*. Furthermore the 3DSTATE_CONSTANT_* must occur in the same order as the 3DSTATE_GATHER_CONSTANT_*. For example if a 3DSTATE_GATHER_CONSTANT_VS occurs before a 3DSTATE_GATHER_CONSTANT_PS, then the 3DSTATE_CONSTANT_VS must occur before the 3DSTATE_CONSTANT_PS.

Programming Note: If Gather pool is enabled, there must be a corresponding 3DSTATE_GATHER_CONSTANT command with any 3DSTATE_CONSTANT for any particular shader. To avoid any update to the Gather pool, and yet program the 3DSTATE_CONSTANT for a particular shader, send a 3DSTATE_GATHER_CONSTANT command with all valid bits set to zero. Gather Pool must be disabled if executing a 3DSTATE_CONSTANT command unless the resource streamer is enabled to process a GATHER command (RS enabled batch and RS has not been disabled with a MI_RS_CONTROL command).

Project:	HSW
Programming Note: The 3DSTATE_GATHER_* command is not committed to the resource streamer engine until the corresponding (same shader) 3DSTATE_BINDING_TABLE_POINTER_* command. For example, the 3DSTATE_GATHER_VS command will not actually generate a buffer in memory until the 3DSTATE_BINDING_TABLE_POINTERS_VS is parsed by the resource streamer.	

3DSTATE_GATHER_GS

Programming Note: The HW generated binding table must be enabled to use this command.

Project:	HSW
Furthermore, the constant buffer block (group of aligned 16 binding table entries) must be set before this command is issued.	

Programming Note: The length of the gather table is derived from the total length of the command. The command length is in DWORDS, but the gather table entries are 16 bit in length. If there is an unused odd entry at the end of the command the channel mask should be set to all 0.

Programming Note: When a 3DSTATE_GATHER_CONSTANT_* command is used there must be a matching 3DSTATE_CONSTANT_*. Furthermore the 3DSTATE_CONSTANT_* must occur in the same order as the 3DSTATE_GATHER_CONSTANT_*. In other words if a 3DSTATE_GATHER_CONSTANT_VS occurs



before a 3DSTATE_GATHER_CONSTANT_PS, then the 3DSTATE_CONSTANT_VS must occur before the 3DSTATE_CONSTANT_PS.

Programming Note: If Gather pool is enabled, there must be a corresponding 3DSTATE_GATHER_CONSTANT command with any 3DSTATE_CONSTANT for any particular shader. If the programmer wants to avoid any update to the Gather pool, and yet program the 3DSTATE_CONSTANT for a particular shader, it can send a 3DSTATE_GATHER_CONSTANT command with all valid bits set to zero. Gather Pool must be disabled if executing a 3DSTATE_CONSTANT command unless the resource streamer is enabled to process a GATHER command (RS enabled batch and RS has not been disabled with a MI_RS_CONTROL command).

Project:	HSW
<p>Programming Note: The 3DSTATE_GATHER_* command is not committed to the resource streamer engine until the corresponding (same shader) 3DSTATE_BINDING_TABLE_POINTER_* command. For example, the 3DSTATE_GATHER_VS command will not actually generate a buffer in memory till the 3DSTATE_BINDING_TABLE_POINTERS_VS is parsed by the resource streamer.</p> <p>Note: The following commands must be executed prior to any 3DSTATE_GATHER_CONSTANT_* command that has Constant Buffer Valid equal to zero:</p> <ul style="list-style-type: none">• 3DPRIMITIVE – To ensure resource streamer initiates produce prior to next command: Indirect Parameter Enable = 0 UAV Coherency Required = 0 Predicate Enable = 0 End Offset Enable = 0 Vertex Access Type = SEQUENTIAL Primitive Topology Type = 3DPRIM_POINTLIST Vertex Count Per Instance = 0 Start Vertex Location = 0 Instance Count = 0 Start Instance Location = 0 Base Vertex Location = 0• MI_RS_STORE_DATA_IMM – To force engine idle prior to executing next instruction. Write must occur to address that will not corrupt memory. Resource Streamer Flush = 1 <p>Note: The following commands must be executed prior to any 3DSTATE_GATHER_CONSTANT_* command that has Constant Buffer Valid greater than zero:</p> <ul style="list-style-type: none">• 3DPRIMITIVE – To ensure resource streamer initiates produce prior to next command: Indirect Parameter Enable = 0 UAV Coherency Required = 0 Predicate Enable = 0 End Offset Enable = 0 Vertex Access Type = SEQUENTIAL Primitive Topology Type = 3DPRIM_POINTLIST Vertex Count Per Instance = 0 Start Vertex Location = 0	



Project:		HSW
Instance Count	= 0	
Start Instance Location	= 0	
Base Vertex Location	= 0	
Note: The following commands must be executed following any 3DSTATE_GATHER_CONSTANT_* command that has Constant Buffer Valid greater than zero:		
<ul style="list-style-type: none">• MI_RS_STORE_DATA_IMM – To force engine idle prior to executing next instruction. Write must occur to address that will not corrupt memory: Resource Streamer Flush = 1• MI_RS_STORE_DATA_IMM – To force all previous writes to coherent memory point. Write must occur to address that will not corrupt memory: Resource Streamer Flush = 1• 3DSTATE_GATHER_CONSTANT_PS – To ensure correct timing of sync between resource streamer and render pipeline: Constant Buffer Valid = 0• 3DSTATE_CONSTANT_PS: Constant Buffer 1 Read Length = 0 Constant Buffer 0 Read Length = 0 Constant Buffer 3 Read Length = 0 Constant Buffer 2 Read Length = 0		



3DSTATE_GATHER_PS

Programming Note: The HW generated binding table must be enabled to use this command.

Project:	HSW
Programming Note: The constant buffer block (group of aligned 16 binding table entries) must be set before this command is issued.	

Programming Note: The length of the gather table is derived from the total length of the command. The command length is in DWords, but the gather table entries are 16 bits in length. If there is an unused odd entry at the end of the command the channel mask should be set to all 0s.

Programming Note: When a 3DSTATE_GATHER_CONSTANT_* command is used there must be a matching 3DSTATE_CONSTANT_*. Furthermore the 3DSTATE_CONSTANT_* must occur in the same order as the 3DSTATE_GATHER_CONSTANT_*. For example if a 3DSTATE_GATHER_CONSTANT_VS occurs before a 3DSTATE_GATHER_CONSTANT_PS, then the 3DSTATE_CONSTANT_VS must occur before the 3DSTATE_CONSTANT_PS.

Programming Note: If Gather pool is enabled, there must be a corresponding 3DSTATE_GATHER_CONSTANT command with any 3DSTATE_CONSTANT for any particular shader. To avoid any update to the Gather pool, and yet program the 3DSTATE_CONSTANT for a particular shader, send a 3DSTATE_GATHER_CONSTANT command with all valid bits set to zero. Gather Pool must be disabled if executing a 3DSTATE_CONSTANT command unless the resource streamer is enabled to process a GATHER command (RS enabled batch and RS has not been disabled with a MI_RS_CONTROL command).



3DSTATE_GATHER_POOL_ALLOC

Programming Note: The gather constant feature has a simple all or nothing model. If the gather constants are enable, the driver must enable the gather pool and use 3D_STATE_GATHER_CONSTANT_* cmds to gather and load the URB. If the gather buffer is disabled the driver must use the existing 3D_STATE_CONSTANT_* cmds to load the URB.

Programming Note: The gather constants can only be enabled if the binding table generator is also enabled.

3DSTATE_GATHER_POOL_ALLOC



3DSTATE_GATHER_CONSTANT_VS

Programming Note: The HW generated binding table must be enabled to use this command.

Project:	HSW
Programming Note: The constant buffer block (group of aligned 16 binding table entries) must be set before this command is issued.	

Programming Note: The length of the gather table is derived from the total length of the command. The command length is in DWords, but the gather table entries are 16 bits in length. If there is an unused odd entry at the end of the command the channel mask should be set to all 0s.

Programming Note: When a 3DSTATE_GATHER_CONSTANT_* command is used there must be a matching 3DSTATE_CONSTANT_*. Furthermore the 3DSTATE_CONSTANT_* must occur in the same order as the 3DSTATE_GATHER_CONSTANT_*. For example if a 3DSTATE_GATHER_CONSTANT_VS occurs before a 3DSTATE_GATHER_CONSTANT_PS, then the 3DSTATE_CONSTANT_VS must occur before the 3DSTATE_CONSTANT_PS.

Programming Note: If Gather pool is enabled, there must be a corresponding 3DSTATE_GATHER_CONSTANT command with any 3DSTATE_CONSTANT for any particular shader. To avoid any update to the Gather pool, and yet program the 3DSTATE_CONSTANT for a particular shader, send a 3DSTATE_GATHER_CONSTANT command with all valid bits set to zero.

3DSTATE_GATHER_CONSTANT_VS



3DSTATE_GATHER_HS

Programming Note: The HW-generated binding table must be enabled to use this command.

Project:	HSW
Programming Note: Furthermore, the constant buffer block (group of aligned 16 binding table entries) must be set before this command is issued.	

Programming Note: The length of the gather table is derived from the total length of the command. The command length is in DWords, but the gather table entries are 16 bits in length. If there is an unused odd entry at the end of the command the channel mask should be set to all 0s.

Programming Note: When a 3DSTATE_GATHER_CONSTANT_* command is used there must be a matching 3DSTATE_CONSTANT_*. Furthermore the 3DSTATE_CONSTANT_* must occur in the same order as the 3DSTATE_GATHER_CONSTANT_*. In other words if a 3DSTATE_GATHER_CONSTANT_VS occurs before a 3DSTATE_GATHER_CONSTANT_PS, then the 3DSTATE_CONSTANT_VS must occur before the 3DSTATE_CONSTANT_PS.

Programming Note: If Gather pool is enabled, there must be a corresponding 3DSTATE_GATHER_CONSTANT command with any 3DSTATE_CONSTANT for any particular shader. If the programmer wants to avoid any update to the Gather pool, and yet program the 3DSTATE_CONSTANT for a particular shader, it can send a 3DSTATE_GATHER_CONSTANT command with all valid bits set to zero.

Project:	HSW
Programming Notes: The 3DSTATE_GATHER_* command is not committed to the resource streamer engine until the corresponding(same shader) 3DSTATE_BINDING_TABLE_POINTER_* command. For example, the 3DSTATE_GATHER_VS command does not actually generate a buffer in memory until the 3DSTATE_BINDING_TABLE_POINTERS_VS is parsed by the resource streamer.	
[HSW] Note: The following commands must be executed <i>before</i> any 3DSTATE_GATHER_CONSTANT_* command that has Constant Buffer Valid equal to zero:	
<ul style="list-style-type: none"> • 3DPRIMITIVE - To ensure resource streamer initiates produce prior to next command: <ul style="list-style-type: none"> Indirect Parameter Enable = 0 UAV Coherency Required = 0 Predicate Enable = 0 End Offset Enable = 0 Vertex Access Type = SEQUENTIAL Primitive Topology Type = 3DPRIM_POINTLIST Vertex Count Per Instance = 0 Start Vertex Location = 0 Instance Count = 0 Start Instance Location = 0 Base Vertex Location = 0 • MI_RS_STORE_DATA_IMM - To force engine idle prior to executing next instruction. Write must occur to address that does not corrupt memory: <ul style="list-style-type: none"> Resource Streamer Flush = 1 	



Note: The following commands must be executed *before* any 3DSTATE_GATHER_CONSTANT_* command that has **Constant Buffer Valid** greater than zero:

- 3DPRIMITIVE - To ensure resource streamer initiates produce prior to next command:

```
Indirect Parameter Enable = 0
UAV Coherency Required   = 0
Predicate Enable         = 0
End Offset Enable        = 0
Vertex Access Type       = SEQUENTIAL
Primitive Topology Type  = 3DPRIM_POINTLIST
Vertex Count Per Instance = 0
Start Vertex Location    = 0
Instance Count           = 0
Start Instance Location  = 0
Base Vertex Location     = 0
```

Note: The following commands must be executed *following* any 3DSTATE_GATHER_CONSTANT_* command that has **Constant Buffer Valid** greater than zero:

- MI_RS_STORE_DATA_IMM - To force engine idle prior to executing next instruction. Write must occur to address that does not corrupt memory:
Resource Streamer Flush = 1
- MI_RS_STORE_DATA_IMM - To force all previous writes to coherent memory point. Write must occur to address that does not corrupt memory:
Resource Streamer Flush = 1
- 3DSTATE_GATHER_CONSTANT_PS - To ensure correct timing of sync between resource streamer and render pipeline:
Constant Buffer Valid = 0
- 3DSTATE_CONSTANT_PS:
Constant Buffer 1 Read Length = 0
Constant Buffer 0 Read Length = 0
Constant Buffer 3 Read Length = 0
Constant Buffer 2 Read Length = 0

3DSTATE_GATHER_CONSTANT_HS



3DSTATE_GATHER_DS

3DSTATE_GATHER_CONSTANT_DS



3DSTATE_GATHER_CONSTANT_GS

Programming Note: The HW generated binding table must be enabled to use this command.

Project:	HSW
Furthermore, the constant buffer block (group of aligned 16 binding table entries) must be set before this command is issued.	

Programming Note: The length of the gather table is derived from the total length of the command. The command length is in DWORDs, but the gather table entries are 16 bit in length. If there is an unused odd entry at the end of the command the channel mask should be set to all 0.

Programming Note: When a 3DSTATE_GATHER_CONSTANT_* command is used there must be a matching 3DSTATE_CONSTANT_*. Furthermore the 3DSTATE_CONSTANT_* must occur in the same order as the 3DSTATE_GATHER_CONSTANT_*. In other words if a 3DSTATE_GATHER_CONSTANT_VS occurs before a 3DSTATE_GATHER_CONSTANT_PS, then the 3DSTATE_CONSTANT_VS must occur before the 3DSTATE_CONSTANT_PS.

Programming Note: If Gather pool is enabled, there must be a corresponding 3DSTATE_GATHER_CONSTANT command with any 3DSTATE_CONSTANT for any particular shader. If the programmer wants to avoid any update to the Gather pool, and yet program the 3DSTATE_CONSTANT for a particular shader, it can send a 3DSTATE_GATHER_CONSTANT command with all valid bits set to zero.

Project:	HSW
<p>Programming Note: The 3DSTATE_GATHER_* command is not committed to the resource streamer engine until the corresponding (same shader) 3DSTATE_BINDING_TABLE_POINTER_* command. For example, the 3DSTATE_GATHER_VS command will not actually generate a buffer in memory till the 3DSTATE_BINDING_TABLE_POINTERS_VS is parsed by the resource streamer.</p>	
<p>Note: The following commands must be executed prior to any 3DSTATE_GATHER_CONSTANT_* command that has Constant Buffer Valid equal to zero:</p>	
<ul style="list-style-type: none"> • 3DPRIMITIVE - To ensure resource streamer initiates produce prior to next command: <ul style="list-style-type: none"> Indirect Parameter Enable = 0 UAV Coherency Required = 0 Predicate Enable = 0 End Offset Enable = 0 Vertex Access Type = SEQUENTIAL Primitive Topology Type = 3DPRIM_POINTLIST Vertex Count Per Instance = 0 Start Vertex Location = 0 Instance Count = 0 Start Instance Location = 0 Base Vertex Location = 0 • MI_RS_STORE_DATA_IMM - To force engine idle prior to executing next instruction. Write must occur to address that will not corrupt memory. <ul style="list-style-type: none"> Resource Streamer Flush = 1 	
<p>Note: The following commands must be executed prior to any 3DSTATE_GATHER_CONSTANT_* command that has</p>	



Constant Buffer Valid greater than zero:

- 3DPRIMITIVE - To ensure resource streamer initiates produce prior to next command:

```
Indirect Parameter Enable = 0
UAV Coherency Required   = 0
Predicate Enable         = 0
End Offset Enable        = 0
Vertex Access Type       = SEQUENTIAL
Primitive Topology Type  = 3DPRIM_POINTLIST
Vertex Count Per Instance = 0
Start Vertex Location    = 0
Instance Count           = 0
Start Instance Location  = 0
Base Vertex Location     = 0
```

Note: The following commands must be executed **following** any 3DSTATE_GATHER_CONSTANT_* command that has **Constant Buffer Valid** greater than zero:

- MI_RS_STORE_DATA_IMM - To force engine idle prior to executing next instruction. Write must occur to address that will not corrupt memory:
Resource Streamer Flush = 1
- MI_RS_STORE_DATA_IMM - To force all previous writes to coherent memory point. Write must occur to address that will not corrupt memory:
Resource Streamer Flush = 1
- 3DSTATE_GATHER_CONSTANT_PS - To ensure correct timing of sync between resource streamer and render pipeline:
Constant Buffer Valid = 0
- 3DSTATE_CONSTANT_PS:
Constant Buffer 1 Read Length = 0
Constant Buffer 0 Read Length = 0
Constant Buffer 3 Read Length = 0
Constant Buffer 2 Read Length = 0

3DSTATE_GATHER_CONSTANT_GS



3DSTATE_GATHER_CONSTANT_PS

Programming Note: The HW generated binding table must be enabled to use this command.

Project:	HSW
Programming Note: The constant buffer block (group of aligned 16 binding table entries) must be set before this command is issued.	

Programming Note: The length of the gather table is derived from the total length of the command. The command length is in DWords, but the gather table entries are 16 bits in length. If there is an unused odd entry at the end of the command the channel mask should be set to all 0s.

Programming Note: When a 3DSTATE_GATHER_CONSTANT_* command is used there must be a matching 3DSTATE_CONSTANT_*. Furthermore the 3DSTATE_CONSTANT_* must occur in the same order as the 3DSTATE_GATHER_CONSTANT_*. For example if a 3DSTATE_GATHER_CONSTANT_VS occurs before a 3DSTATE_GATHER_CONSTANT_PS, then the 3DSTATE_CONSTANT_VS must occur before the 3DSTATE_CONSTANT_PS.

Programming Note: If Gather pool is enabled, there must be a corresponding 3DSTATE_GATHER_CONSTANT command with any 3DSTATE_CONSTANT for any particular shader. To avoid any update to the Gather pool, and yet program the 3DSTATE_CONSTANT for a particular shader, send a 3DSTATE_GATHER_CONSTANT command with all valid bits set to zero.

3DSTATE_GATHER_CONSTANT_PS



Dx9 Constant Buffer Generation

The Dx9 constant model is a set of register that the App can incrementally update. The HW requires a constant buffer which lives until the last shader using that buffer retires. To offload the driver the 3DSTATE_DX9_CONSTANT*_* cmds are added. These commands allow the on-die constant register to be maintained. When all the edits to the constant register have been completed, the 3DSTATE_DX9_GENERATE_ACTIVE_* cmd is used to write out a constant buffer to the Dx9 Constant buffer pool. The Dx9 constant buffers are fixed 8KB in size, w/ a large portion of the 2nd 4KB unused.

Programming Note: The Dx9 constant buffer feature has a simple all or nothing model.

Programming Note: A maximum of 16,383 Binding Tables are allowed in any batch buffer.

Programming Note: The Dx9 constants can only be enabled if the binding table generator is also enabled.

3DSTATE_DX9_CONSTANT_BUFFER_POOL_ALLOC



Vertex Shader Constant

This section contains various commands for the vertex shader constant.

3DSTATE_DX9_CONSTANTF_VS

3DSTATE_DX9_CONSTANTI_VS

Programming Note: The 3DSTATE_DX9_CONSTANTB_VS is a variable length command.

3DSTATE_DX9_CONSTANTB_VS

3DSTATE_DX9_LOCAL_VALID_VS

Project:		HSW
DX9 Constant Buffer Map		
Offset		Cache Line
0x0000	256 4-component Float Constants	0
0x0fff		
0x1000	16 4-component integer constants	64
0x103f		
0x1040	16 1-component boolean constants	68
0x104f		
0x1050	unused	
0x1fff		

3DSTATE_DX9_GENERATE_ACTIVE_VS



Pixel Shader Constant

This section contains various commands for the pixel shader constant.

3DSTATE_DX9_CONSTANTF_PS

3DSTATE_DX9_CONSTANTI_PS

3DSTATE_DX9_CONSTANTB_PS

3DSTATE_DX9_LOCAL_VALID_PS

Project:		HSW
DX9 Constant Buffer Map		
Offset		Cache Line
0x0000	256 4-component Float Constants	0
0x0fff		
0x1000	16 4-component integer constants	64
0x103f		
0x1040	16 1-component boolean constants	68
0x104f		
0x1050	unused	
0x1fff		

3DSTATE_DX9_GENERATE_ACTIVE_PS

>



Shared Functions

3D Sampler

The 3D Sampling Engine provides the capability of advanced sampling and filtering of surfaces in memory.

The sampling engine function is responsible for providing filtered texture values to the Gen Core in response to sampling engine messages. The sampling engine uses SAMPLER_STATE to control filtering modes, address control modes, and other features of the sampling engine. A pointer to the sampler state is delivered with each message, and an index selects one of 16 states pointed to by the pointer. Some messages do not require SAMPLER_STATE. In addition, the sampling engine uses SURFACE_STATE to define the attributes of the surface being sampled. This includes the location, size, and format of the surface as well as other attributes.

Although data is commonly used for *texturing* of 3D surfaces, the data can be used for any purpose once returned to the execution core.

The following table summarizes the various subfunctions provided by the Sampling Engine. After the appropriate subfunctions are complete, the 4-component (reduced to fewer components in some cases) filtered texture value is provided to the Gen Core in order to complete the *sample* instruction.

Subfunction	Description
Texture Coordinate Processing	Any required operations are performed on the incoming pixel's interpolated internal texture coordinates. These operations may include: cube map intersection.
Texel Address Generation	The Sampling Engine will determine the required set of texel samples (specific texel values from specific texture maps), as defined by the texture map parameters and filtering modes. This includes coordinate wrap/clamp/mirror control, mipmap LOD computation and sample and/or miplevel weighting factors to be used in the subsequent filtering operations.
Texel Fetch	The required texel samples will be read from the texture map. This step may require decompression of texel data. The texel sample data is converted to an internal format.
Texture Palette Lookup	For streams which have <i>paletted</i> texture surface formats, this function uses the <i>index</i> values read from the texture map to look up texel color data from the texture palette.
Shadow Pre-Filter Compare	For shadow mapping, the texel samples are first compared to the 3 rd (R) component of the pixel's texture coordinate. The boolean results are used in the texture filter.
Texel Filtering	Texel samples are combined using the filter weight coefficients computed in the Texture Address Generation function. This <i>combination</i> ranges from simply passing through a <i>nearest</i> sample to blending the results of anisotropic filters performed on two mipmap levels. The output of this function is a single 4-component texel value.
Texel Color Gamma Linearization	Performs optional gamma decorrection on texel RGB (not A) values.



Subfunction	Description
Denoise/ Deinterlacer	Performs denoise and deinterlacing functions for video content
8x8 Video Scaler	Performs scaling using an 8x8 filter



Sampling Engine

The Sampling Engine provides the capability of advanced sampling and filtering of surfaces in memory.

The sampling engine function is responsible for providing filtered texture values to the Gen Core in response to sampling engine messages. The sampling engine uses `SAMPLER_STATE` to control filtering modes, address control modes, and other features of the sampling engine. A pointer to the sampler state is delivered with each message, and an index selects one of 16 states pointed to by the pointer. Some messages do not require `SAMPLER_STATE`. In addition, the sampling engine uses `SURFACE_STATE` to define the attributes of the surface being sampled. This includes the location, size, and format of the surface as well as other attributes.

Although data is commonly used for "texturing" of 3D surfaces, the data can be used for any purpose once returned to the execution core.



The following table summarizes the various subfunctions provided by the Sampling Engine. After the appropriate subfunctions are complete, the 4-component (reduced to fewer components in some cases) filtered texture value is provided to the Gen Core in order to complete the *sample* instruction.

Subfunction	Description
Texture Coordinate Processing	Any required operations are performed on the incoming pixel's interpolated internal texture coordinates. These operations may include: cube map intersection.
Texel Address Generation	The Sampling Engine will determine the required set of texel samples (specific texel values from specific texture maps), as defined by the texture map parameters and filtering modes. This includes coordinate wrap/clamp/mirror control, mipmap LOD computation and sample and/or miplevel weighting factors to be used in the subsequent filtering operations.
Texel Fetch	The required texel samples will be read from the texture map. This step may require decompression of texel data. The texel sample data is converted to an internal format.
Texture Palette Lookup	For streams which have "paletted" texture surface formats, this function uses the "index" values read from the texture map to look up texel color data from the texture palette.
Shadow Pre-Filter Compare	For shadow mapping, the texel samples are first compared to the 3 rd (R) component of the pixel's texture coordinate. The boolean results are used in the texture filter.
Texel Filtering	Texel samples are combined using the filter weight coefficients computed in the Texture Address Generation function. This "combination" ranges from simply passing through a "nearest" sample to blending the results of anisotropic filters performed on two mipmap levels. The output of this function is a single 4-component texel value.
Texel Color Gamma Linearization	Performs optional gamma decorrection on texel RGB (not A) values.
Denoise/Deinterlacer	Performs denoise and deinterlacing functions for video content
8x8 Video Scaler	Performs scaling using an 8x8 filter



Texture Coordinate Processing

The Texture Coordinate Processing function of the Sampling Engine performs any operations on the texture coordinates that are required before physical addresses of texel samples can be generated.

Texture Coordinate Normalization

A texture coordinate may have *normalized* or *unnormalized* values. In this function, unnormalized coordinates are normalized.

Normalized coordinates are specified in units relative to the map dimensions, where the origin is located at the upper/left edge of the upper left texel, and the value 1.0 coincides with the lower/right edge of the lower right texel. 3D rendering typically utilizes normalized coordinates.

Unnormalized coordinates are in units of texels and have not been divided (normalized) by the associated map's height or width. Here the origin is located at the upper/left edge of the upper left texel of the base texture map.

Normalized vs. Unnormalized Texture Coordinates

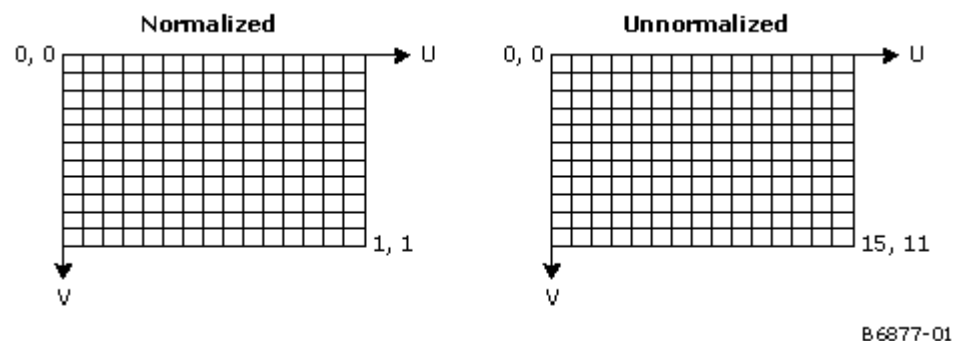

Texture Coordinate Computation

Cartesian (2D) and homogeneous (projected) texture coordinate values are projected from (interpolated) screen space back into texture coordinate space by dividing the pixel's S and T components by the Q component. This operation is done as part of the pixel shader kernel in the Gen4 Core.

Vector (cube map) texture coordinates are generated by first determining which of the 6 cube map faces (+X, +Y, +Z, -X, -Y, -Z) the vector intersects. The vector component (X, Y or Z) with the largest absolute value determines the proper (major) axis, and then the sign of that component is used to select between the two faces associated with that axis. The coordinates along the two minor axes are then divided by the coordinate of the major axis, and scaled and translated, to obtain the 2D texture coordinate ([0,1]) within the chosen face. Note that the coordinates delivered to the sampling engine must already have been divided by the component with the largest absolute value.

An illustration of this cube map coordinate computation, simplified to only two dimensions, is provided below:



Cube Map Coordinate Computation Example

Note:

Face origin is here

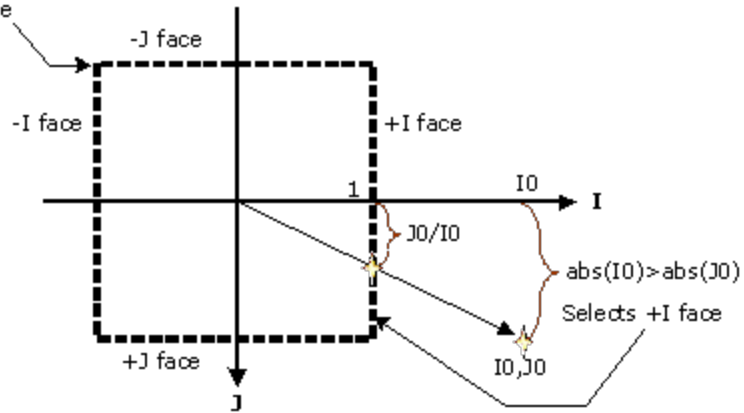

B6878-01



Texel Address Generation

To better understand texture mapping, consider the mapping of each object (screen-space) pixel onto the texture images. In texture space, the pixel becomes some arbitrarily sized and aligned quadrilateral. Any given pixel of the object may "cover" multiple texels of the map, or only a fraction of one texel. For each pixel, the usual goal is to sample and filter the texture image in order to best represent the covered texel values, with a minimum of blurring or aliasing artifacts. Per-texture state variables are provided to allow the user to employ quality/performance/footprint tradeoffs in selecting how the particular texture is to be sampled.

The Texel Address Generation function of the Sampling Engine is responsible for determining how the texture maps are to be sampled. Outputs of this function include the number of texel samples to be taken, along with the physical addresses of the samples and the filter weights to be applied to the samples after they are read. This information is computed given the incoming texture coordinate and gradient values, and the relevant state variables associated with the sampler and surface. This function also applies the texture coordinate address controls when converting the sample texture coordinates to map addresses.

Level of Detail Computation (Mipmapping)

Due to the specification and processing of texture coordinates at object vertices, and the subsequent object warping due to a perspective projection, the texture image may become *magnified* (where a texel covers more than one pixel) or *minified* (a pixel covers more than one texel) as it is mapped to an object. In the case where an object pixel is found to cover multiple texels (texture minification), merely choosing one (e.g., the texel sample nearest to the pixel's texture coordinate) will likely result in severe aliasing artifacts.

Mipmapping and texture filtering are techniques employed to minimize the effect of undersampling these textures. With mipmapping, software provides *mipmap levels*, a series of pre-filtered texture maps of decreasing resolutions that are stored in a fixed (monolithic) format in memory. When mipmaps are provided and enabled, and an object pixel is found to cover multiple texels (e.g., when a textured object is located a significant distance from the viewer), the device will sample the mipmap level(s) offering a texel/pixel ratio as close to 1.0 as possible.

The device supports up to 14 mipmap levels per map surface, ranging from 8192 x 8192 texels to a 1 X 1 texel. Each successive level has $\frac{1}{2}$ the resolution of the previous level in the U and V directions (to a minimum of 1 texel in either direction) until a 1x1 texture map is reached. The dimensions of mipmap levels need not be a power of 2.

Each mipmap level is associated with a *Level of Detail (LOD)* number. LOD is computed as the approximate, \log_2 measure of the ratio of texels per pixel. The highest resolution map is considered LOD 0. A larger LOD number corresponds to lower resolution mip level.

The *Sampler[]BaseMipLevel* state variable specifies the LOD value at which the minification filter vs. the magnification filter should be applied.



When the texture map is magnified (a texel covers more than one pixel), the base map (LOD 0) texture map is accessed, and the magnification mode selects between the nearest neighbor texel or bilinear interpolation of the 4 neighboring texels on the base (LOD 0) mipmap.

Base Level Of Detail (LOD)

The per-pixel LOD is computed in an implementation-dependent manner and approximates the \log_2 of the texel/pixel ratio at the given pixel. The computation is typically based on the differential texel-space distances associated with a one-pixel differential distance along the screen x- and y-axes. These texel-space distances are computed by evaluating neighboring pixel texture coordinates, these coordinates being in units of texels on the base MIP level (multiplied by the corresponding surface size in texels). The q coordinates represent the third dimension for 3D (volume) surfaces, this coordinate is a constant 0 for 2D surfaces.

The ideal LOD computation is included below.

$$LOD(x, y) = \log_2[\rho(x, y)]$$

where :

$$\rho(x, y) = \max \left\{ \sqrt{\left(\frac{\partial u}{\partial x}\right)^2 + \left(\frac{\partial v}{\partial x}\right)^2 + \left(\frac{\partial q}{\partial x}\right)^2}, \sqrt{\left(\frac{\partial u}{\partial y}\right)^2 + \left(\frac{\partial v}{\partial y}\right)^2 + \left(\frac{\partial q}{\partial y}\right)^2} \right\}$$

LOD Bias

A biasing offset can be applied to the computed LOD and used to artificially select a higher or lower miplevel and/or affect the weighting of the selected mipmap levels. Selecting a slightly higher mipmap level will trade off image blurring with possibly increased performance (due to better texture cache reuse). Lowering the LOD tends to sharpen the image, though at the expense of more texture aliasing artifacts.

The LOD bias is defined as sum of the *LODBias* state variable and the *pixLODBias* input from the input message (which can be non-zero only for sample_b messages). The application of LOD Bias is unconditional, therefore these variables must both be set to zero in order to prevent any undesired biasing.

Note that, while the LOD Bias is applied prior to clamping and min/mag determination and therefore can be used to control the min-vs-mag crossover point, its use has the undesired effect of actually changing the LOD used in texture filtering.

LOD Pre-Clamping

The LOD Pre-Clamping function can be enabled or disabled via the *LODPreClampEnable* state variable. Enabling pre-clamping matches OpenGL semantics .



After biasing and/or adjusting of the LOD, the computed LOD value is clamped to a range specified by the (integer and fractional bits of) *MinLOD* and *MaxLOD* state variables prior to use in Min/Mag Determination.

MaxLOD specifies the lowest resolution mip level (maximum LOD value) that can be accessed, even when lower resolution maps may be available. Note that this is the only parameter used to specify the number of valid mip levels that can be accessed, i.e., there is no explicit "number of levels stored in memory" parameter associated with a mip-mapped texture. All mip levels from the base mip level map through the level specified by the integer bits of *MaxLOD* must be stored in memory, or operation is UNDEFINED.

MinLOD specifies the highest resolution mip level (minimum LOD value) that can be accessed, where $LOD=0$ corresponds to the base map. This value is primarily used to deny access to high-resolution mip levels that have been evicted from memory when memory availability is low.

MinLOD and *MaxLOD* have both integer and fractional bits. The fractional parts will limit the inter-level filter weighting of the highest or lowest (respectively) resolution map. For example if *MinLOD* is 4.5 and *MipFilter* is LINEAR, LOD 4 can contribute only up to 50% of the final texel color.

Min/Mag Determination

The biased and clamped LOD is used to determine whether the texture is being minified (scaled down) or magnified (scaled up).

The *BaseMipLevel* state variable is subtracted from the biased and clamped LOD. The *BaseMipLevel* state variable therefore has the effect of selecting the "base" mip level used to compute Min/Map Determination. (This was added to match OpenGL semantics). Setting *BaseMipLevel* to 0 has the effect of using the highest-resolution mip level as the base map.

If the biased and clamped LOD is non-positive, the texture is being magnified, and a single (high-resolution) mip level will be sampled and filtered using the *MagFilter* state variable. At this point the computed LOD is reset to 0.0. Note that LOD Clamping can restrict access to high-resolution mip levels.

If the biased LOD is positive, the texture is being minified. In this case the *MipFilter* state variable specifies whether one or two mip levels are to be included in the texture filtering, and how that (or those) levels are to be determined as a function of the computed LOD.



LOD Computation Pseudocode

This section illustrates the LOD biasing and clamping computation in pseudocode, encompassing the steps described in the previous sections. The computation of the initial per-pixel LOD value *LOD* is not shown.

Project:	HSW
Bias:	S4.8
MinLod:	U4.8
MaxLod:	U4.8
Base:	U4.1
MIPCnt:	U4
SurfMinLod:	U4.8
ResMinLod:	U4.8

PerSampleMinLOD: float32

```

MinLod      = max(MinLod, PerSampleMinLOD)
AdjMaxLod   = min(MaxLod, MIPCnt)
AdjMinLod   = min(MinLod, MIPCnt)
AdjPR_minLOD = ResMinLod - SurfMinLod
AdjMinLod   = max(AdjMinLod, AdjPR_minLOD)
Out_of_Bounds = AdjPR_minLOD > MIPCnt

```

```

if ( sample_b )
    LOD += Bias + bias_parameter
else if ( sample_l or ld )
    LOD = Bias + lod_parameter
else
    LOD += Bias

```

Project	Pseudocode
HSW	<pre> PreClamp = LODPreClampEnable if (PreClamp) LOD = min(LOD, MaxLod) LOD = max(LOD, MinLod) </pre>

MagMode = (LOD - Base <= 0)

Project	Pseudocode
HSW	MagClampMipNone = 1
HSW	MagClampMipNone = LODClampMagnificationMode == MAG_CLAMP_MIPNONE

```

if ( (MagMode && MagClampMipNone) or MipFlt == None )
    LOD = 0
    LOD = min(LOD, ceil(AdjMaxLod))
    LOD = max(LOD, floor(AdjMinLod))
else if ( MipFlt == Nearest )

```



Project	Pseudocode
HSW	<pre> LOD = min(LOD, ceil(AdjMaxLod)) LOD = max(LOD, floor(AdjMinLod)) </pre>

```

LOD += 0.5
LOD = floor(LOD)
else
  // MipFlt = Linear
  LOD = min(LOD, AdjMaxLod)
  LOD = max(LOD, AdjMinLod)
  TriBeta = frac(LOD)
  LOD0 = floor(LOD)
  LOD1 = LOD0 + 1

if ( ! lod ) // "LOD" message type
  Lod += SurfMinLod

```

If `Out_of_Bounds` is true, LOD is set to zero and instead of sampling the surface the texels are replaced with zero in all channels, except for surface formats that don't contain alpha, for which the alpha channel is replaced with one. These texels then proceed through the rest of the pipeline.

Inter-Level Filtering Setup

The `MipFilter` state variable determines if and how texture mip maps are to be used and combined. The following table describes the various mip filter modes:

<i>MipFilter</i> Value	Description
MIPFILTER_NONE	Mipmapping is DISABLED. Apply a single filter on the highest resolution map available (after LOD clamping).
MIPFILTER_NEAREST	Choose the nearest mipmap level and apply a single filter to it. Here the biased LOD will be rounded to the nearest integer to obtain the desired miplevel. LOD Clamping may further restrict this miplevel selection.
MIPFILTER_LINEAR	Apply a filter on the two closest mip levels and linear blend the results using the distance between the computed LOD and the level LODs as the blend factor. Again, LOD Clamping may further restrict the selection of miplevels (and the blend factor between them).

When minifying and MIPFILTER_NEAREST is selected, the computed LOD is rounded to the nearest mip level.

When minifying and MIPFILTER_LINEAR is selected, the fractional bits of the computed LOD are used to generate an inter-level blend factor. The LOD is then truncated. The mip level selected by the truncated LOD, and the next higher (lower resolution) mip level are determined.

Regardless of `MipFilter` and the min/mag determination, all computed LOD values (two for MIPFILTER_LINEAR, otherwise one) are then unconditionally clamped to the range specified by the (integer bits of) `MinLOD` and `MaxLOD` state variables.



Intra-Level Filtering Setup

Depending on whether the texture is being minified or magnified, the *MinFilter* or *MagFilter* state variable (respectively) is used to select the sampling filter to be used within a mip level (intra-level, as opposed to any inter-level filter). Note that for volume maps, this selection also applies to filtering between layers.

The processing at this stage is restricted to the selection of the filter type, computation of the number and texture map coordinates of the texture samples, and the computation of any required filter parameters. The filtering of the samples occurs later on in the Sampling Engine function.



The following table summarizes the intra-level filtering modes.

Sampler[]Min/MagFilter value	Description
MAPFILTER_NEAREST	Supported on all surface types. The texel nearest to the pixel's U,V,Q coordinate is read and output from the filter.
MAPFILTER_LINEAR	Not supported on buffer surfaces. The 2, 4, or 8 texels (depending on 1D, 2D/CUBE, or 3D surface, respectively) surrounding the pixel's U,V,Q coordinate are read and a linear filter is applied to produce a single filtered texel value.
MAPFILTER_ANISOTROPIC	Not supported on buffer or 3D surfaces. A projection of the pixel onto the texture map is generated and "subpixel" samples are taken along the major axis of the projection (center axis of the longer dimension). The outermost subpixels are weighted according to closeness to the edge of the projection, inner subpixels are weighted equally. Each subpixel samples a bilinear 2x2 of texels and the results are blended according to weights to produce a filtered texel value.
MAPFILTER_MONO	Supported only on 2D surfaces. This filter is only supported with the monochrome (MONO8) surface format. The monochrome texel block of the specified size surrounding the pixel is selected and filtered.

MAPFILTER_NEAREST

When the MAPFILTER_NEAREST is selected, the texel with coordinates nearest to the pixel's texture coordinate is selected and output as the single texel sample coordinates for the level.

MAPFILTER_LINEAR

The following description indicates behavior of the MIPFILTER_LINEAR filter for 2D and CUBE surfaces. 1D and 3D surfaces follow a similar method but with a different number of dimensions available.

When the MAPFILTER_LINEAR filter is selected on a 2D surface, the 2x2 region of texels surrounding the pixel's texture coordinate are sampled and later bilinearly filtered.



Bilinear Filter Sampling

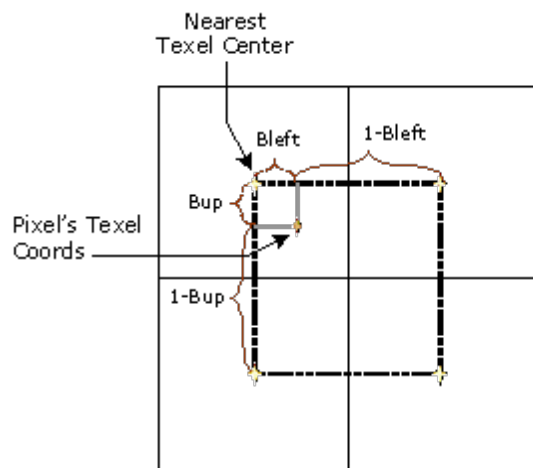

B6879-01

The four texels surrounding the pixel center are chosen for the bilinear filter. The filter weights each texel's contribution according to its distance from the pixel center. Texels further from the pixel center receive a smaller weight.

MAPFILTER_ANISOTROPIC

The MAPFILTER_ANISOTROPIC texture filter attempts to compensate for the anisotropic mapping of pixels into texture map space. A possibly non-square set of texel sample locations will be sampled and later filtered. The *MaxAnisotropy* state variable is used to select the maximum aspect ratio of the filter employed, up to 16:1.

The algorithm employed first computes the major and minor axes of the pixel projection onto the texture map. LOD is chosen based on the minor axis length in texel space. The anisotropic "ratio" is equal to the ratio between the major axis length and the minor axis length. The next larger even integer above the ratio determines the anisotropic number of "ways", which determines how many subpixels are chosen. A line along the major axis is determined, and "subpixels" are chosen along this line, spaced one texel apart, as shown in the diagram below. In this diagram, the texels are shown in light blue, and the pixels are in yellow.

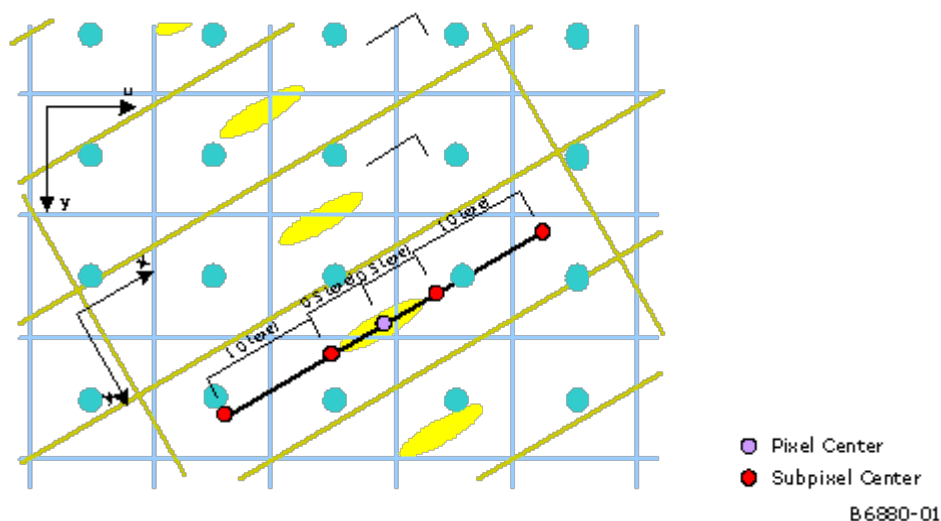

Each subpixel samples a bilinear 2x2 around it just as if it was a single pixel. The result of each subpixel is then blended together using equal weights on all interior subpixels (not including the two endpoint subpixels). The endpoint subpixels have lesser weight, the value of which depends on how close the "ratio" is to the number of "ways". This is done to ensure continuous behavior in animation.

MAPFILTER_MONO

When the MAPFILTER_MONO filter is selected, a block of monochrome texels surrounding the pixel sample location are read and filtered using the kernel described below. The size of this block is controlled by **Monochrome Filter Height** and **Width** (referred to here as N_v and N_u , respectively) state. Filters from 1x1 to 7x7 are supported (not necessarily square).

The figure below shows a 6x5 filter kernel as an example. The footprint of the filter (filter kernel samples) is equal to the size of the filter and the pixel center lies at the exact center of this footprint. The position of the upper left filter kernel sample (u_f, v_f) relative to the pixel center at (u, v) is given by the following:

$$u_f = u - \frac{N_u}{2}$$

$$v_f = v - \frac{N_v}{2}$$



β_u and β_v are the fractional parts of u_f and v_f , respectively. The integer parts select the upper left texel for the kernel filter, given here as $T_{0,0}$.

Sampling Using MAPFILTER_MONO

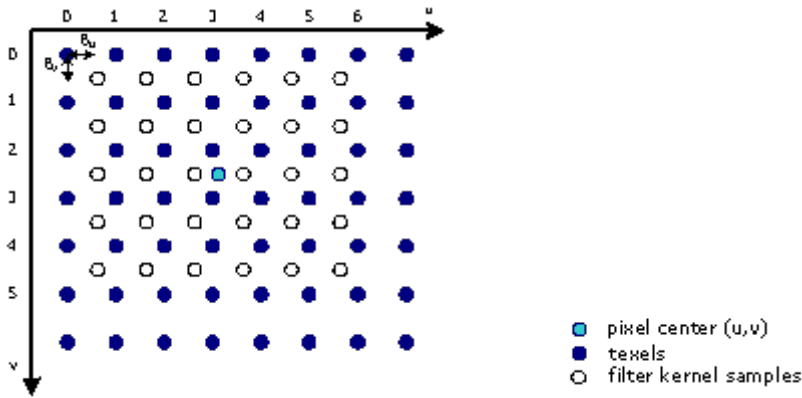

B6881-01

The formula for the final filter output F is given by the following. Since this is a monochrome filter, each texel value (T) is a single bit, and the output F is an intensity value that is replicated across the color and alpha channels.

$$S = \frac{1}{N_u * N_v}$$

$$F = \left[(1 - \beta_u)(1 - \beta_v) \sum_{i=0}^{N_u-1} \sum_{j=0}^{N_v-1} T_{i,j} + \beta_u(1 - \beta_v) \sum_{i=1}^{N_u} \sum_{j=0}^{N_v-1} T_{i,j} + (1 - \beta_u)\beta_v \sum_{i=0}^{N_u-1} \sum_{j=1}^{N_v} T_{i,j} + \beta_u\beta_v \sum_{i=1}^{N_u} \sum_{j=1}^{N_v} T_{i,j} \right] * S$$



Texture Address Control

The $[TCX,TCY,TCZ]$ *ControlMode* state variables control the access and/or generation of texel data when the specific texture coordinate component falls *outside* of the normalized texture map coordinate range $[0,1)$.

Note: For **Wrap Shortest** mode, the setup kernel has already taken care of correctly interpolating the texture coordinates. Software needs to specify `TEXCOORDMODE_WRAP` mode for the sampler that is provided with wrap-shortest texture coordinates, or artifacts may be generated along map edges.

<i>TC[X,Y,Z] Control</i>	<i>Operation</i>
<code>TEXCOORDMODE_CLAMP</code>	Clamp to the texel value at the edge of the map.
<code>TEXCOORDMODE_CLAMP_BORDER</code>	Use the texture map's border color for any texel samples falling outside the map. The border color is specified via a pointer in <code>SAMPLER_STATE</code> .
<code>TEXCOORDMODE_HALF_BORDER</code>	Similar to <code>CLAMP_BORDER</code> except texels outside of the map are clamped to a value halfway between the edge texel and the border color.
<code>TEXCOORDMODE_WRAP</code>	Upon crossing an edge of the map, repeat at the other side of the map in the same dimension.
<code>TEXCOORDMODE_CUBE</code>	Only used for cube maps. Here texels from adjacent cube faces can be sampled along the edges of faces. This is considered the highest quality mode for cube environment maps.
<code>TEXCOORDMODE_MIRROR</code>	Similar to the wrap mode, though reverse direction through the map each time an edge is crossed. <code>INVALID</code> for use with unnormalized texture coordinates.
<code>TEXCOORDMODE_MIRROR_ONCE</code>	Similar to the wrap mode, though reverse direction through the map each time an edge is crossed. <code>INVALID</code> for use with unnormalized texture coordinates.

Separate controls are provided for texture `TCX`, `TCY`, `TCZ` coordinate components so, for example, the `TCX` coordinate can be wrapped while the `TCY` coordinate is clamped. Note that there are no controls provided for the `TCW` component as it is only used to scale the other 3 components before addressing modes are applied.

Maximum Wraps/Mirrors

The number of map wraps on a given object is limited to 32. Going beyond this limit is legal, but may result in artifacts due to insufficient internal precision, especially evident with larger surfaces. Precision loss starts at the subtexel level (slight color inaccuracies) and eventually reaches the texel level (choosing the wrong texels for filtering).



TEXCOORDMODE_MIRROR Mode

TEXCOORDMODE_MIRROR addressing mode is similar to Wrap mode, though here the base map is flipped at every integer junction. For example, for U values between 0 and 1, the texture is addressed normally, between 1 and 2 the texture is flipped (mirrored), between 2 and 3 the texture is normal again, and so on. The second row of pictures in the figure below indicate a map that is mirrored in one direction and then both directions. You can see that in the mirror mode every other integer map wrap the base map is mirrored in either direction.

Texture Wrap vs. Mirror Addressing Mode

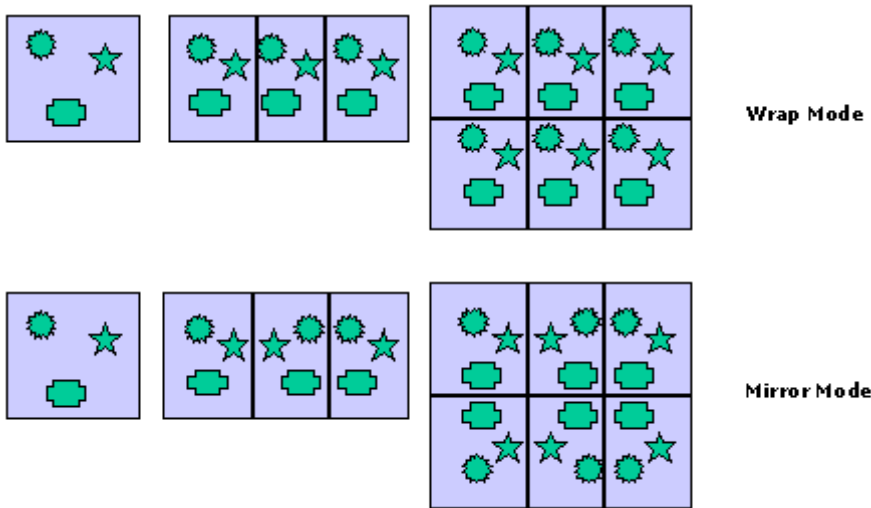

B.6882-01

TEXCOORDMODE_WRAP Mode

In TEXCOORDMODE_WRAP addressing mode, the integer part of the texture coordinate is discarded, leaving only a fractional coordinate value. This results in the effect of the base map ([0,1)) being continuously repeated in all (axes-aligned) directions. Note that the interpolation between coordinate values 0.1 and 0.9 passes through 0.5 (as opposed to WrapShortest mode which interpolates through 0.0).

TEXCOORDMODE_MIRROR_ONCE Mode

The TEXCOORDMODE_MIRROR_ONCE addressing mode is a combination of Mirror and Clamp modes. The absolute value of the texture coordinate component is first taken (thus mirroring about 0), and then the result is clamped to 1.0. The map is therefore mirrored once about the origin, and then clamped thereafter. This mode is used to reduce the storage required for symmetric maps.

TEXCOORDMODE_CLAMP Mode

The TEXCOORDMODE_CLAMP addressing mode repeats the "edge" texel when the texture coordinate extends outside the [0,1) range of the base texture map. This is contrasted to TEXCOORDMODE_CLAMPBORDER mode which defines a separate texel value for off-map samples. TEXCOORDMODE_CLAMP is also supported for cube maps, where texture samples will only be obtained from the intersecting face (even along edges).

The figure below illustrates the effect of clamp mode. The base texture map is shown, along with a texture mapped object with texture coordinates extending outside of the base map region.

Texture Clamp Mode

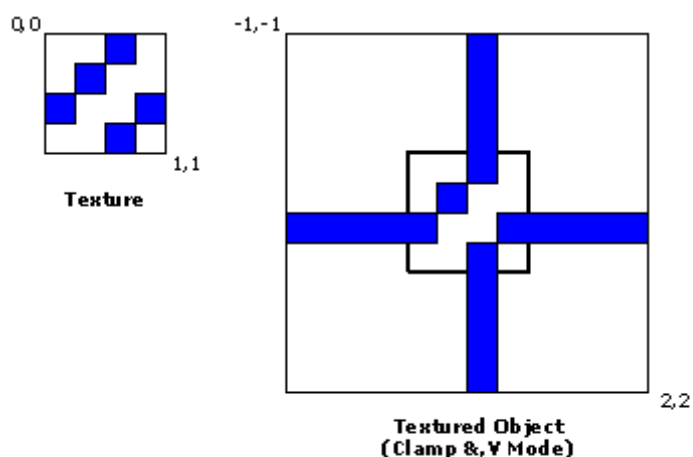

B 6883-01

TEXCOORDMODE_CLAMPBORDER Mode

For non-cube map textures, TEXCOORDMODE_CLAMPBORDER addressing mode specifies that the texture map's border value *BorderColor* is to be used for any texel samples that fall outside of the base map. The border color is specified via a pointer in SAMPLER_STATE.

TEXCOORDMODE_CUBE Mode

For cube map textures TEXCOORDMODE_CUBE addressing mode can be set to allow inter-face filtering. When texel sample coordinates that extend beyond the selected cube face (e.g., due to intra-level filtering near a cube edge), the correct sample coordinates on the adjoining face will be computed. This will eliminate artifacts along the cube *edges*, though some artifacts at cube *corners* may still be present.



Texel Fetch

The Texel Fetch function of the Sampling Engine reads the texture map contents specified by the texture addresses associated with each texel sample. The texture data is read either directly from the memory-resident texture map, or from internal texture caches. The texture caches can be invalidated by the **Sampler Cache Invalidate** field of the MI_FLUSH instruction or via the **Read Cache Flush Enable** bit of PIPE_CONTROL. Except for consideration of coherency with CPU writes to textures and rendered textures, the texture cache does not affect the functional operation of the Sampling Engine pipeline.

When the surface format of a texture is defined as being a compressed surface, the Sampler will automatically decompress from the stored format into the appropriate [A]RGB values. The compressed texture storage formats and decompression algorithms can be found in the *Memory Data Formats* chapter. When the surface format of a texture is defined as being an index into the texture palette (format names including "Px"), the palette lookup of the index determines the appropriate RGB values.

Texel Chroma Keying

ChromaKey is a term used to describe a method of effectively removing or replacing a specific range of texel values from a map that is applied to a primitive, e.g., in order to define transparent regions in an RGB map. The Texel Chroma Keying function of the Sampling Engine pipeline conditionally tests texel samples against a "key" range, and takes certain actions if any texel samples are found to match the key.

Chroma Key Testing

ChromaKey refers to testing the texel sample components to see if they fall within a range of texel values, as defined by *ChromaKey*[[High,Low] state variables. If each component of a texel sample is found to lie within the respective (inclusive) range and ChromaKey is enabled, then an action will be taken to remove this contribution to the resulting texel stream output. Comparison is done separately on each of the channels and only if all 4 channels are within range the texel will be eliminated.

The Chroma Keying function is enabled on a per-sampler basis by the *ChromaKeyEnable* state variable.

The *ChromaKey*[[High,Low] state variables define the tested color range for a particular texture map.



Chroma Key Effects

There are two operations that can be performed to "remove" matching texel samples from the image. The *ChromaKeyEnable* state variable must first enable the chroma key function. The *ChromaKeyMode* state variable then specifies which operation to perform on a per-sampler basis.

The *ChromaKeyMode* state variable has the following two possible values:

KEYFILTER_KILL_ON_ANY_MATCH: Kill the pixel if any contributing texel sample matches the key.

KEYFILTER_REPLACE_BLACK: Here the sample is replaced with (0,0,0,0).

The Kill Pixel operation has an effect on a pixel only if the associated sampler is referenced by a sample instruction in the pixel shader program. If the sampler is not referenced, the chroma key compare is not done and pixels cannot be killed based on it.



Shadow Prefilter Compare

When a *sample_c* message type is processed, a special shadow-mapping precomparison is performed on the texture sample values prior to filtering. Specifically, each texture sample value is compared to the "ref" component of the input message, using a compare function selected by *ShadowFunction*, and described in the table below. Note that only single-channel texel formats are supported for shadow mapping, and so there is no specific color channel on which the comparison occurs.

<i>ShadowFunction</i>	Result
PREFILTEROP_ALWAYS	0.0
PREFILTEROP_NEVER	1.0
PREFILTEROP_LESS	(texel < ref) 0.0 : 1.0
PREFILTEROP_EQUAL	(texel == ref) 0.0 : 1.0
PREFILTEROP_LEQUAL	(texel <= ref) 0.0 : 1.0
PREFILTEROP_GREATER	(texel > ref) 0.0 : 1.0
PREFILTEROP_NOTEQUAL	(texel != ref) 0.0 : 1.0
PREFILTEROP_GEQUAL	(texel >= ref) 0.0 : 1.0

The binary result of each comparison is fed into the subsequent texture filter operation (in place of the texel's value which would normally be used).

Software is responsible for programming the "ref" component of the input message such that it approximates the same distance metric programmed in the texture map (e.g., distance from a specific light to the object pixel). In this way, the comparison function can be used to generate "in shadow" status for each texture sample, and the filtering operation can be used to provide soft shadow edges.

Programming Note: Refer to the Surface Formats table in section **RENDER_SURFACE_STATE** for the specific surface formats that are supported with shadow mapping.



Texel Filtering

The Texel Filtering function of the Sampling Engine performs any required filtering of multiple texel values on and possibly between texture map layers and levels. The output of this function is a single texel color value.

The state variables *MinFilter*, *MagFilter*, and *MipFilter* are used to control the filtering of texel values. The *MipFilter* state variable specifies how many mipmap levels are included in the filter, and how the results of any filtering on these separate levels are combined to produce a final texel color. The *MinFilter* and *MagFilter* state variables specify how texel samples are filtered within a level.



Texel Color Gamma Linearization

This function is supported to allow pre-gamma-corrected texel RGB (not A) colors to be mapped back into linear (gamma=1.0) gamma space prior to (possible) blending with, and writing to the Color Buffer. This permits higher quality image blending by performing the blending on colors in linear gamma space.

This function is enabled on a per-texture basis by use of a surface format with "_SRGB" in its name. If enabled, the pre-filtered texel RGB color to be converted from gamma=2.4 space to gamma=1.0 space by applying a $^{1/2.4} = ^{0.4167}$ exponential function.



Multisampled Surface Behavior

The *ld* message has added an additional parameter for sample index (*si*) to support unfiltered loading from a multisampled surface.

The *sampleinfo* message returns specific parameters associated with a multisample surface. The *resinfo* message returns the height, width, depth, and MIP count of the surface (in units of *pixels*, not samples).

Any of the other messages (*sample**, *LOD*, *load4*) used with a (4x) multisampled surface would sample a surface with double the height and width as indicated in the surface state. Each pixel position on the original-sized surface is replaced with 2x2 samples that have the following arrangement:

sample 0	sample 2
sample 1	sample 3

This behavior is useful when implementing the multisample resolve operation by selecting *MAPFILTER_LINEAR* and rendering a full-screen rectangle half the size in each dimension of the source texture map (multisampled surface). If pixel offsets are set correctly, each pixel is the average of the four underlying samples.

Multisample Control Surface

Three new messages have been defined for the sampling engine, *ld_mcs*, *ld2dms*, and *ld2dss*. A pixel shader kernel sampling from an multisampled surface using an MCS must first sample from the MCS surface using the *ld_mcs* message. This message behaves like the *ld* message, except that the surface is defined by the MCS fields of *SURFACE_STATE* rather than the normal fields. The surface format is effectively *R8_UINT* for 4x surfaces and *R32_UINT* for 8x surfaces, thus data is returned in unsigned integer format. Following the *ld_mcs*, the kernel issues a *ld2dms* message to sample the surface itself. The integer value from the MCS surface is delivered in the *mcs* parameter of this messages.

Since *sample* is no longer supported on multisampled surfaces, the multisample resolve must be done using *ld2dms*. For surfaces with **Multisampled Surface Storage Format** set to *MSFMT_MSS* and **MCS Enable** set to enabled, an optimization is available to enable higher performance for compressed pixels. The *ld2dss* message can be used to sample from a particular sample slice on the surface. By examining the MCS value, software can determine which sample slices to sample from. A simple optimization with probable large return in performance is to compare the MCS value to zero (indicating all samples are on sample slice 0), and sample only from sample slice 0 using *ld2dss* if MCS is zero. Sample slice 0 is the pixel color in this case. If MCS is not zero, each sample is then obtained using *ld2dms* messages and the results are averaged in the kernel after being returned. Refer to the multisample storage format in the GPU Overview volume for more details.



State

BINDING_TABLE_STATE

SW Generated BINDING_TABLE_STATE

HW Generated BINDING_TABLE_STATE

SURFACE_STATE for Deinterlace, sample_8x8, and VME

This section contains media surface state definitions.

MEDIA_SURFACE_STATE

Restrictions: The Faulting modes described in the MEMORY_OBJECT_CONTROL_STATE should be set to the same for the multi-surface Video Analytics functions like "LBP Correlation" and "Correlation Search" for both the surfaces.

SAMPLER_STATE

SAMPLER_STATE has different formats, depending on the message type used. The sample_8x8 and deinterlace messages use a different format of SAMPLER_STATE as detailed in the corresponding sections.

Project:
The Min LOD and Max LOD fields need range increased from [0.0,13.0] to [0.0,14.0] and fractional bits increased from 6 to 8. This requires a few fields to be moved as indicated in the text.

SAMPLER_STATE

SAMPLER_STATE for Sample_8x8 Message

Project	Description
	IEF Filter Type was dropped and is assumed to be Detailed filter.
	IEF Filter Size was dropped and assumed to be 5x5.
	IEF Bypass – If we have Y/G-channel masked then the IEF bypass should always be forced to 1.

DEINTERLACE_SAMPLER_STATE

Project:
This state definition is used only by the <i>deinterlace</i> message. This state is stored as an array of up to 8 elements, each of which contains the DWords described here. The start of each element is spaced 8 DWords apart. The first element of the array is aligned to a 32-byte boundary. The index with range 0-7 that selects which element is being used is multiplied by 2 to determine the Sampler Index in the message descriptor.



Restrictions

1. VDIWalker can be enabled only when frame is aligned to block size of 16x4 if DI is enabled (interlaced) and 16x8 if DN only (Progressive).
2. When VDIWalker Frame Sharing is enabled driver should dispatch same number of Media Objects to both half slice by explicitly programming half slice destination select as 01b and 10b alternately. (**Note:** Dispatch of threads should be in ping pong fashion to have load balance between both Halfslice and better L3 utilization.)
3. For VDIWalker disabled mode (when frame size is not aligned to 16x4 or 16x8) it is recommended to have a simplified SW walker. Using Half Slice Destination Select 00b will affect performance significantly.

Dispatch of Media Object Commands for VDIWalker Enabled

1. Frame Sharing is Disabled:
 - a. Program all MO commands to have Half Slice destination select as either 01b or 10b.
 - b. Y_stride programmed in Sampler State will be ignored.
2. Frame Sharing Enabled:
 - a. If Frame_height (in blocks) % 2 = 0 (where block height = 4 when DI enabled, 8 when DN only) dispatch MO in ping pong fashion.
 - b. Y_Stride of 0,1,2,3 is valid and VDIwalker will divide frame into multiple slices based on stride value.
 - c. If Frame_height (in blocks) % 2 > 0, then dispatch MO in ping pong fashion and all threads for blocks from residual row to be sent to Half Slice0.

Media Object Dispatch Pseudocode

```
// Variables:
Frame Height in pixels => frame_height
Frame Width in pixels => frame_width
Frame Height in Blocks => fh
Frame Width in Blocks => fw
Block Height in Pixels => block_height = Interlaced ? 4 : 8

// Code:
fw = frame_width / 16;
fh = frame_height / block_height;
```



Calculate Residual Blocks Pseudocode

```
If ( fh % (2**stride) ) ≠ 0 {
    Y_Blocks_Remainder = (fh % (2**stride))
    If ( Y_Blocks_Remainder > (2**stride) / 2 ) {
        Y_Blocks_Remainder_HS1 = (2**stride) / 2
        Y_Blocks_Remainder_HS2 = Y_Blocks_Remainder - (2**stride) / 2
    }
    Else {
        Y_Blocks_Remainder_HS1 = Y_Blocks_Remainder
        Y_Blocks_Remainder_HS2 = 0
    }
}
Else {
    Y_Blocks_Remainder_HS1 = 0
    Y_Blocks_Remainder_HS2 = 0
}
```

Dispatch Media Object Pseudocode

```
total_media_obj_cnt = fw * fh;
remainder_media_obj_cnt_HS1 = fw * Y_Blocks_Remainder_HS1;
remainder_media_obj_cnt_HS2 = fw * Y_Blocks_Remainder_HS2;

ping_pong_media_obj_cnt = total_media_obj_cnt - (remainder_media_obj_cnt_HS1 +
remainder_media_obj_cnt_HS2);

for ( i = 0; i < ping_pong_media_obj_cnt; i++ ) {
    if ( i % 2 == 0 ) {
        dispatch_media_object_hs1;
    }
    else {
        dispatch_media_object_hs2;
    }
}

for ( i = 0; i < remainder_media_obj_cnt_HS1; i++ ) {
    dispatch_media_object_hs1;
}

for ( i = 0; i < remainder_media_obj_cnt_HS2; i++ ) {
    dispatch_media_object_hs2;
}
```

SAMPLER_8x8_STATE

SAMPLER_BORDER_COLOR_STATE

If border color is used, all formats must be provided. Hardware will choose the appropriate format based on **Surface Format** and **Texture Border Color Mode**. The values represented by each format should be the same (other than being subject to range-based clamping and precision) to avoid unexpected behavior.



DWord	Bits	Description
0	31:24	Border Color Alpha Format = UNORM8
	23:16	Border Color Blue Format = UNORM8
	15:8	Border Color Green Format = UNORM8
	7:0	Border Color Red Format = UNORM8
1	31:0	Border Color Red Format = IEEE_FP
2	31:0	Border Color Green Format = IEEE_FP
3	31:0	Border Color Blue Format = IEEE_FP
4	31:0	Border Color Alpha Format = IEEE_FP
5	31:16	Border Color Green Format = FLOAT16
	15:0	Border Color Red Format = FLOAT16
6	31:16	Border Color Alpha Format = FLOAT16
	15:0	Border Color Blue Format = FLOAT16
7	31:16	Border Color Green



DWord	Bits	Description
		Format = UNORM16
	15:0	Border Color Red Format = UNORM16
8	31:16	Border Color Alpha Format = UNORM16
	15:0	Border Color Blue Format = UNORM16
9	31:16	Border Color Green Format = SNORM16
	15:0	Border Color Red Format = SNORM16
10	31:16	Border Color Alpha Format = SNORM16
	15:0	Border Color Blue Format = SNORM16
11	31:24	Border Color Alpha Format = SNORM8
	23:16	Border Color Blue Format = SNORM8
	15:8	Border Color Green Format = SNORM8
	7:0	Border Color Red Format = SNORM8



Border Color Programming for Integer Surface Formats

For integer formats, there are different possible cases depending on the bits per channel (bpc) and bits per texel (bpt) of the surface format.

Integer Surface Format – Different Types	Surface formats
32 bpc, 128 bpt case (4 types)	R32G32B32A32_UINT R32G32B32_UINT R32G32B32A32_SINT R32G32B32_SINT
16 bpc, 64 bpt case (5 types)	R16G16B16A16_UINT, R10G10B10A2_UINT X32_TYPELESS_G8X24_UINT R16G16B16_UINT R16G16B16A16_SINT R16G16B16_SINT
32 bpc, 64 bpt case (2 types)	R32G32_UINT R32G32_SINT
8 bpc, 32 bpt cases (9 types)	R8G8B8A8_UINT R8G8_UINT R8_UINT X24_TYPELESS_G8_UINT R8G8B8_UINT R8G8B8A8_SINT R8G8_SINT R8_SINT R8G8B8_SINT
16 bpc, 32 bpt cases (4 types)	R16G16_UINT R16_UINT R16G16_SINT R16_SINT
32 bpc, 32 bpt case (2 types)	R32_UINT R32_SINT



HW supports only 1 index for a given Sampler Border Color state and Sampler State. So, SW will have to program the table in **SAMPLER_BORDER_COLOR_STATE** at DWord offsets 16 to 19, as per the integer surface format type (depends on the bits per channel and bits per texel of the surface format). If any color channel is missing from the surface format, the corresponding border color should be programmed as zero; if the alpha channel is missing, the corresponding Alpha border color should be programmed as 1. Some of the representative cases are listed below:

Project:		HSW
Case 1: R32G32B32A32_UINT (32 bpc, 128 bpt, 4 channels)		
DWORDN	31:0	Border Color Red ui32 (integer unclamp) Format: INT32 Texture Border Color Mode = DX10/OGL
DWORDN+1	31:0	Border Color Green ui32 (integer unclamp) Format: INT32 Texture Border Color Mode = DX10/OGL
DWORDN+2	31:0	Border Color Blue ui32 (integer unclamp) Format: INT32 Texture Border Color Mode = DX10/OGL
DWORDN+3	31:0	Border Color Alpha ui32 (integer unclamp) Format: INT32 Texture Border Color Mode = DX10/OGL

Case 2: R32G32B32A32_SINT (32 bpc, 128 bpt, 4 channel, SINT)

Each of the values in the above table would have to be programmed as sint32 value.



Case 3: R32G32B32_UINT (32 bpc, 128 bpt, 3 channel)

R/G/B values would be programmed like in Case1. Alpha channel value at DWORDN+3 would have to be programmed as Integer 1.

Project:		HSW
Case 4: R32_UINT (32 bpc, 32 bpt, 1 channel)		
DWORDN	31:0	Border Color Red ui32 (integer unclamp) Format: INT32 Texture Border Color Mode = DX10/OGL
DWORDN+1	31:0	Border Color Green ui32 (integer unclamp) Should be programmed as integer 0. Format: INT32 Texture Border Color Mode = DX10/OGL
DWORDN+2	31:0	Border Color Blue ui32 (integer unclamp) Should be programmed as integer 0. Format: INT32 Texture Border Color Mode = DX10/OGL
DWORDN+3	31:0	Border Color Alpha ui32 (integer unclamp) Should be programmed as integer 1. Format: INT32 Texture Border Color Mode = DX10/OGL
Case5: R16G16B16A16_UINT (16 bpc, 64 bpt, 4 channel, UINT)		
DWORDN	15:0	Border Color Red clamp to uint16 Format: U16 Texture Border Color Mode = DX10/OGL
	31:16	Border Color Green clamp to uint16 Format: U16 Texture Border Color Mode = DX10/OGL
DWORDN+1	31:0	Reserved



Project:		HSW
		Format: MBZ
DWORDN+2	15:0	Border Color Blue clamp to uint16 Format: U16 Texture Border Color Mode = DX10/OpenGL
	31:16	Border Color Alpha clamp to uint16 Format: U16 Texture Border Color Mode = DX10/OpenGL
DWORDN+3	31:0	Reserved Format: MBZ
Case 6: R8G8B8A8_SINT (8 bpc, 32 bpt, 4 channels, SINT)		
DWORDN	7:0	Border Color Red clamp to sint8 Format: U8 Texture Border Color Mode = DX10/OpenGL
	15:8	Border Color Green clamp to sint8 Format: U8 Texture Border Color Mode = DX10/OpenGL
	23:16	Border Color Blue clamp to sint8 Format: U8 Texture Border Color Mode = DX10/OpenGL
	31:24	Border Color Alpha clamp to sint8 Format: U8 Texture Border Color Mode = DX10/OpenGL
DWORDN+1	31:0	Reserved Format: MBZ
DWORDN+2	31:0	Reserved Format: MBZ



Project:		HSW
DWORDN+3	31:0	Reserved Format: MBZ
Case 7: R32G32_UINT (32bpc, 64bpt, 2 channel case)		
DWORDN	31:0	Border Color Red ui32 (integer unclamp) Format: INT32 Texture Border Color Mode = DX10/OGL
DWORDN+1	31:0	Reserved Format: MBZ
DWORDN+2	31:0	Border Color Green ui32 (integer unclamp) Format: INT32 Texture Border Color Mode = DX10/OGL
DWORDN+3	31:0	Reserved Format: MBZ
Case 8: R8_UINT (8 bpc, 32 bpt, 1 channel case)		
DWORDN	7:0	Border Color Red clamp to uint8 Format: U8 Texture Border Color Mode = DX10/OGL
	15:8	Border Color Green Should be programmed as integer 0. Format: U8 Texture Border Color Mode = DX10/OGL
	23:16	Border Color Blue clamp to uint8 Should be programmed as integer 0. Format: U8 Texture Border Color Mode = DX10/OGL
	31:24	Border Color Alpha clamp to uint8



Project:		HSW
		Should be programmed as integer 1. Format: U8 Texture Border Color Mode = DX10/OGL
DWORDN+1	31:0	Reserved Format: MBZ
DWORDN+2	31:0	Reserved Format: MBZ
DWORDN+3	31:0	Reserved Format: MBZ
Case 9: R16G16_UINT (16 bpc, 32 bpt case)		
DWORDN	15:0	Border Color Red clamp to uint16 Format: U16 Texture Border Color Mode = DX10/OGL
	31:16	Border Color Green clamp to uint16 Format: U16 Texture Border Color Mode = DX10/OGL
DWORDN+1	31:0	Reserved Format: MBZ
DWORDN+2	15:0	Border Color Blue clamp to uint16 Format: U16 Texture Border Color Mode = DX10/OGL
	31:16	Border Color Alpha clamp to uint16 Program as Integer 1. Format: U16 Texture Border Color Mode = DX10/OGL
DWORDN+3	31:0	Reserved



Project:		HSW	
		Format: MBZ	

3DSTATE_CHROMA_KEY

3DSTATE_SAMPLER_PALETTE_LOAD0

3DSTATE_MONOFILTER_SIZE



Messages

Restrictions:

- Use of any message to the Sampling Engine function with the **End of Thread** bit set in the message descriptor is not allowed.

Initiating Message

Execution Mask

SIMD16. The 16-bit execution mask forms the valid pixel signals. This determines which pixels are sampled and results returned to the GRF registers. Samples for invalid pixels are not overwritten in the GRF. However, if LOD needs to be computed for a subspan based on the message type and MIP filter mode and at least one pixel in the subspan being valid, the sampling engine assumes that the parameters for the upper left, upper right, and lower left pixels in the subspan are valid regardless of the execution mask, as these are needed for the LOD computation.

SIMD8. The lower 8 bits of the execution mask forms the valid pixel signals. If LOD needs to be computed based on MIP filter mode and at least one pixel in the subspan being valid, the sampling engine assumes that the parameters for the upper left, upper right, and lower left pixels in the subspan are valid regardless of the execution mask, since these are needed for the LOD computation.

SIMD4x2. The lower 8 bits of the execution mask is interpreted in groups of four. If any of the high 4 bits are asserted, that sample is valid. If any of the low 4 bits are asserted, that sample is valid. The **Write Channel Mask** rather than the execution mask determines which channels are written back to the GRF.

SIMD32. The execution mask is ignored, all pixels are considered valid, and all channels are returned regardless of the execution mask.



Project:		HSW
Message Descriptor		
Bits	Description	
19	Header Present: Specifies whether the message includes a header phase. If the header is not present (this field is zero), all of the fields normally contained in the header are assumed to be 0. Format = Enable	
18:17	SIMD Mode: Specifies the SIMD mode of the message being sent. Format = U2 0 = SIMD4x2 1 = SIMD8 2 = SIMD16 3 = SIMD32/64	
16:12	Message Type: Specifies the type of message being sent. Format = U5 Refer to the table in the Payload Parameter Definition section for encoding details.	
11:8	Sampler Index: Specifies the index into the sampler state table. Ignored for "ld", "resinfo", "sampleinfo" and "cache_flush" type messages. Format = U4 Range = [0,15] Programming Notes: <ul style="list-style-type: none">• For the deinterlace message, this field must be a multiple of 2 (even).• For the sample_8x8 message, this field must be a multiple of 4.	
7:0	Binding Table Index: Specifies the index into the binding table. Ignored for "cache_flush" type messages. Format = U8 Range = [0,255]	



Message Header

The message header for the sampling engine is the same regardless of the message type. If the header is not present, the behavior is as if the message was sent with all fields in the header set to zero (write channel masks are all enabled and offsets are zero). When Response length is 0 for sample_8x8 message then the data from sampler is directly written out to memory using media write message.

DWord	Bits	Description	Project	Security
M0.5	31:0	Reserved		
M0.4	31:0	Reserved		
M0.3	31:5	Sampler State Pointer: Specifies the 32-byte aligned pointer to the sampler state table. This field is ignored for "ld" and "resinfo" message types. This pointer is relative to the Dynamic State Base Address . Format = DynamicStateOffset[31:5]		
	4:0	Reserved		
M0.2 spans so many rows, many for various projects, that the DWord value is repeated in each row.				
M0.2	31:22	Reserved		
M0.2	21	Reserved		
M0.2	20	Reserved		
M0.2	19:18	SIMD32/64 Output Format Control Specifies the output format of SIMD32/64 messages (sample_unorm* and sample_8x8). Ignored for other message types. Refer to the writeback message formats for details on how this field affects returned data. 0: 16 bit Full 1: 16 bit Chrominance Downsampled 2: 8 bit Full 3: 8 bit Chrominance Downsampled		
M0.2	19:18	SIMD32/64 Output Format Control Specifies the output format of SIMD32/64 messages (sample_unorm* and sample_8x8). Ignored for other message types. Refer to the writeback message formats for details on how this field affects returned data. This field is ignored for sample_8x8 messages if the Function is not AVS and		



DWord	Bits	Description	Project	Security
		<p>MinMaxFilter. For MinMaxFilter only 16bit Full and 8bit Full modes are supported.</p> <p>This field is ignored and not used for HDC write message.</p> <p>0: 16 bit Full</p> <p>1: 16 bit Chrominance Downsampled</p> <p>2: 8 bit Full</p> <p>3: 8 bit Chrominance Downsampled</p>		
M0.2	17:16	<p>Gather4 Source Channel Select: Selects the source channel to be sampled in the gather4* messages. Ignored for other message types.</p> <p>0: Red channel</p> <p>1: Green channel</p> <p>2: Blue channel</p> <p>3: Alpha channel</p> <p>Programming Note: For gather4*_c messages, this field must be set to 0 (Red channel).</p>		
M0.2	14	<p>Blue Write Channel Mask: See Alpha Write Channel Mask.</p>		
M0.2	13	<p>Green Write Channel Mask: See Alpha Write Channel Mask.</p>		
M0.2	12	<p>Red Write Channel Mask: See Alpha Write Channel Mask.</p>		
M0.2	11:8	<p>U Offset: The u offset from the _aoffimmi modifier on the "sample" or "ld" instruction in DX10. Must be zero if the Surface Type is SURFTYPE_CUBE or SURFTYPE_BUFFER. Must be set to zero if _aoffimmi is not specified. Format is S3 2's complement.</p> <p>Programming Notes:</p> <ul style="list-style-type: none"> This field is ignored for the sample_unorm*, sample_8x8, and deinterlace messages. This field is ignored if the "offu" parameter is included in the gather4* messages. Note: HSW offu/offv are calculated in normalized space and hence 		



DWord	Bits	Description	Project	Security
		subject to a small truncation error.		
M0.2	7:4	<p>V Offset: The v offset from the _aoffimmi modifier on the "sample" or "ld" instruction in DX10. Must be zero if the Surface Type is SURFTYPE_CUBE or SURFTYPE_BUFFER. Must be set to zero if _aoffimmi is not specified. Format is S3 2's complement.</p> <p>Programming Notes:</p> <ul style="list-style-type: none"> This field is ignored for the sample_unorm*, sample_8x8, and deinterlace messages. This field is ignored if the "offu" parameter is included in the gather4* messages. Note: offu/offv are calculated in normalized space and hence subject to a small truncation error. 		
M0.2	3:0	<p>R Offset: The r offset from the _aoffimmi modifier on the "sample" or "ld" instruction in DX10. Must be zero if the Surface Type is SURFTYPE_CUBE or SURFTYPE_BUFFER. Must be set to zero if _aoffimmi is not specified. Format is S3 2's complement.</p> <p>Programming Note:</p> <ul style="list-style-type: none"> This field is ignored for the sample_unorm*, sample_8x8, and deinterlace messages. 		
M0.1	31:0	Reserved		
M0.0	31:0	Reserved		

Payload Parameter Definition

The following sections show all of the messages supported by the sampling engine. The message type field in the message descriptor in combination with the message length determines which message is being sent. The table defines all of the *parameters* sent for each message type. The position of the parameters in the payload is given in the section following corresponding to the *SIMD mode* given in the table. The instruction column indicates the DX10 shader instructions expected to be translated to each message type.

All parameters are of type IEEE_Float, except those in the ld and resinfo instruction message types, which are of type S31. Any parameter indicated with a blank entry in the table is unused. A message register containing only unused parameters is not included as part of the message. The response lengths given



below assume that all channels are unmasked. SIMD16 messages with masked channels have reduced response lengths.

For the SIMD32/SIMD64 messages, the input message is not defined in terms of parameters. "H" is 1 if the header is present, 0 otherwise.

SIMD32/SIMD64 Messages

Message Type	Mnemonic	Payload Layout	Message Length	Response Length
00000	sample_unorm	Pixel Shader	H + 1	8 **
00010	sample_unorm+killpix	Pixel Shader	H + 1	9 **
00011	sample_8x8	Pixel Shader	H + 1	16 *
01000	deinterlace	Pixel Shader	H + 1	†
01100	sample_unorm	Media	H + 1	8 **
01010	sample_unorm+killpix	Media	H + 1	9 **
01011	sample_8x8	Media	H + 1	16 *

* For sample_8x8, phases in the response length are reduced by 4 for each channel that is masked.

** For sample_unorm, phases in the response length are reduced by 2 for each channel that is masked.

† For deinterlace, response length depending on certain state fields. Refer to writeback message definition for details.

Project	Description
HSW	Parameter 0 is required except for the sampleinfo message, which has no parameter 0.

SIMD Mode	Message Length	Project
SIMD4x2	H + (N/4)	
SIMD8 SIMD8D	H + N	
SIMD16	H + (2*N)	

The response lengths are computed as follows:

Determining Response Lengths

Project	SIMD Mode	Message Type	Return Format	Response Length
	SIMD4x2	All	32-bit	1
	SIMD8	sample+killpix	32-bit	5
	SIMD8	All other message types	32-bit	4
	SIMD16	All	32-bit	8 *
	SIMD16	All	16-bit	4 *



Notes for Determining Response Lengths Table

Project	Symbol	Note
	*	<p>For SIMD16, phases in the response length are reduced by 2 for each channel that is masked.</p> <p>SIMD16 messages with six or more parameters exceed the maximum message length allowed, in which case they are not supported. This includes some forms of sample_b_c, sample_l_c, and gather4_po_c message types. Note that even for these messages, if 5 or fewer parameters are included in the message, the SIMD16 form of the message is allowed. SIMD16 forms of sample_d and sample_d_c are not allowed, regardless of the number of parameters sent.</p>

Project:												
SIMD4x2 Messages												
Message Type	Mnemonic	Parameters										
		0	1	2	3	4	5	6	7	8	9	10
00010	sample_l	u	v	r	ai	lod						
00100	sample_d	u	v	r	ai	dudx	dudy	dvdx	dvdy	drdx	drdy	
00110	sample_l_c	u	v	r	ai	ref	lod					
00111	ld	u	v	r	lod							
01000	gather4	u	v	r	ai							
01010	resinfo	lod										
01011	sampleinfo											
10000	gather4_c	u	v	r	ai	ref						
10001	gather4_po	u	v	r	ai	offu	offv					
10010	gather4_po_c	u	v	r	ref	offu	offv					
10100	sample_d_c	u	v	r	ai	dudx	dudy	dvdx	dvdy	drdx	drdy	ref
11100	ld2dms_w	u	v	r		si	mcs	mcs				
11101	ld_mcs	u	v	r								
11110	ld2dms	u	v	r		si	mcs					

SIMD32/SIMD64 Messages

Message Type	Mnemonic	Payload Layout	Message Length	Response Length
00000	sample_unorm	Pixel Shader	H + 1	8 **
00010	sample_unorm+killpix	Pixel Shader	H + 1	9 **
01000	deinterlace	Pixel Shader	H + 1	†



Message Type	Mnemonic	Payload Layout	Message Length	Response Length
01100	sample_unorm	Media	H + 1	8 **
01010	sample_unorm+killpix	Media	H + 1	9 **
01011	sample_8x8	Media	H + 1	16 *
11111	cache_flush	no payload	1	1

* For sample_8x8, phases in the response length are reduced by 4 for each channel that is masked.

** For sample_unorm, phases in the response length are reduced by 2 for each channel that is masked.

† For deinterlace, response length depending on certain state fields. Refer to writeback message definition for details.

Project:	HSW
For output control modes other than "16 bit Full", the response lengths are reduced accordingly. Refer to the writeback message format definitions to determine the correct response length for each case.	

Message Types

Programming Note: For surfaces of type SURFTYPE_CUBE, the sampling engine requires u, v, and r parameters that have already been divided by the absolute value of the parameter (u, v, or r) with the largest absolute value.

The behavior of each message type is as follows:

Message Type	Project	Description or Restriction
sample		The surface is sampled using the indicated sampler state. LOD is computed using gradients between adjacent pixels. One, two, or three parameters may be specified depending on how many coordinate dimensions the indicated surface type uses. Extra parameters specified are ignored. Missing parameters are defaulted to 0. The Surface Type of the associated surface must be SURFTYPE_1D, SURFTYPE_2D, SURFTYPE_3D, or SURFTYPE_CUBE. The Surface Format of the associated surface cannot be MONO8. sample is not supported in SIMD4x2 mode.
sample		If the Surface Format of the associated surface is UINT or SINT, the Surface Type cannot be SURFTYPE_3D or SURFTYPE_CUBE and Address Control Mode cannot be CLAMP_BORDER or HALF_BORDER.
sample		Number of Multisamples on the associated surface must be MULTISAMPLECOUNT_1.
sample+killpix		The surface is sampled as in the sample message type. An additional register is returned after the sample results which contains the kill pixel mask. This message type is required to allow the result of a chroma key enabled sampler in KEYFILTER_KILL_ON_ANY_MATCH mode to affect the final pixel mask. The Surface Type of the associated surface must be SURFTYPE_1D, SURFTYPE_2D, SURFTYPE_3D, or



Message Type	Project	Description or Restriction
		<p>SURFTYPE_CUBE.</p> <p>The Surface Format of the associated surface cannot be MONO8.</p> <p>sample+killpix is supported only in SIMD8 mode.</p> <p>Number of Multisamples on the associated surface must be MULTISAMPLECOUNT_1.</p>
sample+killpix		<p>If the Surface Format of the associated surface is UINT or SINT, the Surface Type cannot be SURFTYPE_3D or SURFTYPE_CUBE and Address Control Mode cannot be CLAMP_BORDER or HALF_BORDER.</p>
sample_b		<p>The surface is sampled using the indicated sampler state. LOD is computed using gradients between adjacent pixels, then the value in the parameter is added to the LOD for each pixel. The LOD bias delivered in the bias parameter is restricted to a range of [-16.0, +16.0). Values outside this range produce undefined results.</p> <p>The Surface Type of the associated surface must be SURFTYPE_1D, SURFTYPE_2D, SURFTYPE_3D, or SURFTYPE_CUBE.</p> <p>The Surface Format of the associated surface cannot be MONO8.</p> <p>Number of Multisamples on the associated surface must be MULTISAMPLECOUNT_1.</p> <p>sample_b is not supported in SIMD4x2 mode.</p>
sample_b		<p>If the Surface Format of the associated surface is UINT or SINT, the Surface Type cannot be SURFTYPE_3D or SURFTYPE_CUBE and Address Control Mode cannot be CLAMP_BORDER or HALF_BORDER.</p>
sample_l sample_lz		<p>The surface is sampled using the indicated sampler state. LOD is not computed, but instead is taken from the lod parameter.</p> <p>The Surface Type of the associated surface must be SURFTYPE_1D, SURFTYPE_2D, SURFTYPE_3D, or SURFTYPE_CUBE.</p> <p>Number of Multisamples on the associated surface must be MULTISAMPLECOUNT_1.</p>
sample_l sample_lz		<p>If the Surface Format of the associated surface is UINT or SINT, the Surface Type cannot be SURFTYPE_3D or SURFTYPE_CUBE and Address Control Mode cannot be CLAMP_BORDER or HALF_BORDER.</p>
sample_c sample_c_lz		<p>The surface is sampled using the indicated sampler state. All four coordinates must be specified; however v and r may not be used depending on the indicated surface type. The ai parameter indicates the array index for a cube surface. The ref parameter specifies the reference value that is compared against the red channel of the sampled surface, and the texel is replaced with either white or black depending on the result of the comparison.</p> <p>The Surface Type of the associated surface must be SURFTYPE_1D, SURFTYPE_2D, or SURFTYPE_CUBE.</p> <p>The Surface Format of the associated surface must be indicated as supporting shadow mapping as indicated in the surface format table.</p> <p>With <i>sample_c</i>, MIPFILTER_LINEAR, MAPFILTER_LINEAR, MAPFILTER_ANISOTROPIC are allowed even for surface formats that are listed as not supporting filtering in the surface formats table.</p> <p>Use of the SIMD4x2 form of <i>sample_c</i> without Force LOD to Zero enabled in the message header</p>



Message Type	Project	Description or Restriction
		<p>is not allowed, as it is not possible for the hardware to compute LOD for SIMD4x2 messages. <i>sample_c</i> is not supported in SIMD4x2 mode.</p> <p>Use of <i>sample_c</i> with DX9 Texture Border Color Mode and either of the following is undefined:</p> <p>Use of <i>sample_c</i> with SURFTYPE_CUBE surfaces is undefined with the following surface formats: I24X8_UNORM, L24X8_UNORM, A24X8_UNORM, I32_FLOAT, L32_FLOAT, and A32_FLOAT.</p> <p>Number of Multisamples on the associated surface must be MULTISAMPLECOUNT_1.</p> <ul style="list-style-type: none"> Any applicable Address Control Mode (depending on Surface Type) is set to TEXCOORDMODE_CLAMP_BORDER or TEXCOORDMODE_HALF_BORDER. Surface Type is SURFTYPE_CUBE and any Cube Face Enable is disabled.
sample_c sample_c_lz		The WGF sample_c_lz instruction is implemented by issuing the sample_c message with Force LOD to Zero enabled in the message header or by issuing the sample_l_c message with the LOD parameter set to zero.
sample_b_c		This is a combination of <i>sample_b</i> and <i>sample_c</i> . Both the LOD bias and reference values are delivered. All restrictions applying to both <i>sample_b</i> and <i>sample_c</i> must be honored.
sample_l_c		This is a combination of sample_l and sample_c. Both the LOD and reference values are delivered. All restrictions applying to both sample_l and sample_c must be honored. However, unlike sample_c, sample_l_c is allowed as a SIMD4x2 message.
sample_g sample_d		<p>The surface is sampled using the indicated sampler state. LOD is computed using the gradients present in the message. The <i>r</i> coordinate and its gradients are required only for surface types that use the third coordinate. Usage of this message type on cube surfaces assumes that the <i>u</i>, <i>v</i>, and gradients have already been transformed onto the appropriate face, but still in [-1,+1] range. The <i>r</i> coordinate contains the faceid, and the <i>r</i> gradients are ignored by hardware.</p> <p>The Surface Type of the associated surface must be SURFTYPE_1D, SURFTYPE_2D, SURFTYPE_3D, or SURFTYPE_CUBE.</p> <p>The Surface Format of the associated surface cannot be MONO8.</p> <p>Number of Multisamples on the associated surface must be MULTISAMPLECOUNT_1.</p>
sample_g sample_d		If the Surface Format of the associated surface is UINT or SINT, the Surface Type cannot be SURFTYPE_3D or SURFTYPE_CUBE and Address Control Mode cannot be CLAMP_BORDER or HALF_BORDER.
sample_g sample_d	HSW:A 0	Note: The hardware will not set <i>dv*</i> and <i>dq*</i> parameters to zero if they are not provided in the message. Thus these parameters must be provided even for surfaces that do not use them, 1D and 2D surfaces.
sample_g_c sample_d_c		This is a combination of sample_g and sample_c. Both the gradients for calculating LOD and reference values are delivered. All restrictions applying to both sample_g and sample_c must be honored. However, unlike sample_c, sample_g_c is allowed as a SIMD4x2 message.
resinfo		The surface indicated in the surface state is not sampled. Instead, the width, height, depth, and MIP count of the surface are returned as indicated in the table below. The format of the returned data is UINT32. The width, height, and depth may be shifted right, per pixel, by the LOD value provided in the lod parameter to give the dimensions of the specified mip level. The lod parameter is an unsigned 32-bit integer in this mode (note that sending a signed 32-bit integer always has the same effect, as negative values are out-of-range when interpreted as unsigned integers). The



Message Type	Project	Description or Restriction																																													
		<p>Sampler State Pointer and Sampler Index are ignored.</p> <p>For SURFTYPE_1D, 2D, 3D, and CUBE surfaces, if the delivered LOD is outside of the range [0..MipCount-1], the returned values in the red, green, and blue channels are 0s.</p> <table border="1"> <thead> <tr> <th>Surface Type</th> <th>Project</th> <th>Red</th> <th>Green</th> <th>Blue</th> <th>Alpha</th> </tr> </thead> <tbody> <tr> <td>SURFTYPE_1D</td> <td></td> <td>(Width+1)>>LOD</td> <td>Surface Array Depth+1 : 0</td> <td>0</td> <td>MIPCount</td> </tr> <tr> <td>SURFTYPE_2D</td> <td></td> <td>(Width+1)>>LOD</td> <td>(Height+1)>>LOD</td> <td>Surface Array Depth+1 : 0</td> <td>MIPCount</td> </tr> <tr> <td>SURFTYPE_3D</td> <td></td> <td>(Width+1)>>LOD</td> <td>(Height+1)>>LOD</td> <td>(Depth+1)>>LOD</td> <td>MIPCount</td> </tr> <tr> <td>SURFTYPE_CUBE</td> <td></td> <td>(Width+1)>>LOD</td> <td>(Height+1)>>LOD</td> <td>Surface Array Depth+1 : 0</td> <td>MIPCount</td> </tr> <tr> <td>SURFTYPE_BUFFER SURFTYPE_STRBUF</td> <td></td> <td>Buffer size (from combined Depth/Height/Width). If buffer size is exactly 2^{32}, zero is returned in this field.</td> <td>Undefined</td> <td>Undefined</td> <td>Undefined</td> </tr> <tr> <td>SURFTYPE_NULL</td> <td></td> <td>0</td> <td>0</td> <td>0</td> <td>0</td> </tr> </tbody> </table>				Surface Type	Project	Red	Green	Blue	Alpha	SURFTYPE_1D		(Width+1)>>LOD	Surface Array Depth+1 : 0	0	MIPCount	SURFTYPE_2D		(Width+1)>>LOD	(Height+1)>>LOD	Surface Array Depth+1 : 0	MIPCount	SURFTYPE_3D		(Width+1)>>LOD	(Height+1)>>LOD	(Depth+1)>>LOD	MIPCount	SURFTYPE_CUBE		(Width+1)>>LOD	(Height+1)>>LOD	Surface Array Depth+1 : 0	MIPCount	SURFTYPE_BUFFER SURFTYPE_STRBUF		Buffer size (from combined Depth/Height/Width). If buffer size is exactly 2^{32} , zero is returned in this field.	Undefined	Undefined	Undefined	SURFTYPE_NULL		0	0	0	0
Surface Type	Project	Red	Green	Blue	Alpha																																										
SURFTYPE_1D		(Width+1)>>LOD	Surface Array Depth+1 : 0	0	MIPCount																																										
SURFTYPE_2D		(Width+1)>>LOD	(Height+1)>>LOD	Surface Array Depth+1 : 0	MIPCount																																										
SURFTYPE_3D		(Width+1)>>LOD	(Height+1)>>LOD	(Depth+1)>>LOD	MIPCount																																										
SURFTYPE_CUBE		(Width+1)>>LOD	(Height+1)>>LOD	Surface Array Depth+1 : 0	MIPCount																																										
SURFTYPE_BUFFER SURFTYPE_STRBUF		Buffer size (from combined Depth/Height/Width). If buffer size is exactly 2^{32} , zero is returned in this field.	Undefined	Undefined	Undefined																																										
SURFTYPE_NULL		0	0	0	0																																										
ld ld2dms ld2dms_w ld_mcs ld2dss ld_lz		<p>The surface is sampled using a default sampler state, indicated below. The <i>lod</i> parameter contains the LOD of the mip map to be sampled. If the message doesn't include an lod parameter, the message samples from LOD 0. The parameter <i>si</i> contains the sample index, which is clamped to the number of samples on the surface. The v and r channel may be ignored depending on the indicated surface type. All incoming values are unsigned 32-bit integers in this mode. The u, v, and r parameters contain integer texel addresses on the LOD indicated in the parameter. The Sampler State Pointer and Sampler Index are ignored.</p> <p>For these message types, the sampler state is defaulted as follows:</p> <ul style="list-style-type: none"> min, mag, and mip filter modes are "nearest". All address control modes are "zero", a special mode in which any texel off the map or outside the MIP range of the surface has a value of zero in all channels, except for surface formats without an alpha channel, which return a value of one in the alpha channel. <p>The Surface Type of the associated surface must be SURFTYPE_1D, SURFTYPE_2D, SURFTYPE_3D, or SURFTYPE_BUFFER for the ld message.</p> <p>The Surface Type of the associated surface must be SURFTYPE_2D for the ld_mcs, ld2dms, and ld2dss messages.</p> <p>The Surface Format of the associated surface cannot be MONO8.</p>																																													
ld		<p>The ld_mcs message uses the MCS Base Address and MCS Surface Pitch fields in SURFACE_STATE to determine the base address and pitch of the surface. Surface Format is overridden to R8_UINT if Number of Multisamples is 4, or R32_UINT if Number of Multisamples is 8. This message cannot be</p>																																													



Message Type	Project	Description or Restriction
ld2dms ld2dms_w ld_mcs ld2dss ld_lz		used on a non-multisampled surface. Otherwise, ld_mcs behaves like the ld message. If ld_mcs is issued on a surface with MCS disabled, this message returns zeros in all channels.
ld ld2dms ld2dms_w ld_mcs ld2dss ld_lz		<p>The mcs parameter in the ld2dms message defines the multisample control data and is used only to sample from a multisampled surface.</p> <p>The ssi parameter in the ld2dss message defines the sample slice that will be sampled from. Refer to the multisample storage format in the GPU Overview volume for more details.</p> <p>Number of Multisamples on the associated surface must be MULTISAMPLECOUNT_1 for the ld message type.</p>
ld ld2dms ld2dms_w ld_mcs ld2dss ld_lz		<p>Note: For the out of bound case, the following surface formats return zero in the alpha channel: R32G32B32X32_FLOAT, X32_TYPELESS_G8X24_UINT, R16G16B16X16_UNORM, R16G16B16X16_FLOAT, X24_TYPELESS_G8_UINT, L24X8_UNORM, L32_FLOAT, B8G8R8X8_UNORM, B8G8R8X8_UNORM_SRGB, R8G8B8X8_UNORM, R8G8B8X8_UNORM_SRGB, B10G10R10X2_UNORM, B5G6R5_UNORM, B5G6R5_UNORM_SRGB, L16_UNORM, R5G5_SNORM_B6_UNORM, L8_UNORM, L8_UNORM_SRGB, and R1_UNORM, BC4_UNORM (DXT4/5).</p>
sampleinfo		<p>The surface indicated in the surface state is not sampled. Instead, the number of samples (UINT32) and the sample position palette index (UINT32) for the surface are returned in the red and alpha channels respectively as UINT32 values. The sample position palette index returned in alpha is incremented by one from its value in the surface state. The Sampler State Pointer and Sampler Index are ignored.</p> <p>The Surface Type of the associated surface must be SURFTYPE_2D or SURFTYPE_NULL.</p>
LOD		<p>The surface indicated in the surface state is not sampled. Instead, LOD is computed as if the surface will be sampled, using the indicated sampler state, and the clamped and unclamped LOD values are returned in the red and green channels, respectively, in FLOAT32 format. The blue and alpha channels are undefined, and can be masked to avoid returning them. LOD is computed using gradients between adjacent pixels. Three parameters are always specified, with extra parameters not needed for the surface being ignored.</p> <p>The Surface Type of the associated surface must be SURFTYPE_1D, SURFTYPE_2D, SURFTYPE_3D, or SURFTYPE_CUBE.</p> <p>The Surface Format of the associated surface cannot be MONO8.</p> <p>LOD is not supported in SIMD4x2 mode.</p> <p>Number of Multisamples on the associated surface must be MULTISAMPLECOUNT_1.</p>
LOD		Before HSW:C0, the Surface Format of the associated surface cannot be any UINT or SINT format.



Message Type	Project	Description or Restriction				
gather4 gather4_po (load4)		<p>The surface is sampled using bilinear filtering, regardless of the filtering mode specified in the sampler state. For SURFTYPE_2D, LOD is forced to zero before sampling. The samples are not filtered, but instead the four samples are returned directly in the sample's corresponding four channels as follows:</p> <table border="1"> <tr> <td>upper left sample = alpha channel</td> <td>upper right sample = blue channel</td> </tr> <tr> <td>lower left sample = red channel</td> <td>lower right sample = green channel</td> </tr> </table> <p>Two or three parameters may be specified depending on how many coordinate dimensions the indicated surface type uses. Extra parameters specified are ignored. Missing parameters default to 0.</p> <p>The Surface Type of the associated surface must be SURFTYPE_2D or SURFTYPE_CUBE. If the message type is gather4_po, only SURFTYPE_2D is allowed.</p> <p>The Surface Format of the associated surface cannot be MONO8.</p> <p>Mip Mode Filter must be set to MIPFILTER_NONE.</p> <p>Number of Multisamples on the associated surface must be MULTISAMPLECOUNT_1.</p> <p>Use of gather4 or gather4_po with DX9 Border Color Mode and either of the following is underfined:</p> <ul style="list-style-type: none"> Any applicable Address Control Mode (depending on Surface Type) is set to TEXCOORDMODE_CLAMP_BORDER or TEXCOORDMODE_HALF_BORDER. Surface Type is SURFTYPE_CUBE and any Cube Face Enable is disabled. 	upper left sample = alpha channel	upper right sample = blue channel	lower left sample = red channel	lower right sample = green channel
upper left sample = alpha channel	upper right sample = blue channel					
lower left sample = red channel	lower right sample = green channel					
gather4 gather4_po (load4)		<p>The gather4_po message has offu and offv parameters, which contain texel-space offsets that override the U/V Offset fields in the message header. Unlike the message header fields however, these offsets have a wider range [-32,+31], and can differ per pixel or sample. The format of the data is 32-bit 2's complement signed integer, but hardware only interprets the least significant 6 bits of each value, treating it as a 6-bit 2's complement signed integer.</p> <p>The channel selected is determined by the Gather4 Source Channel Select field in the message header.</p>				
gather4 gather4_po (load4)		<p>The Surface Format of the associated surface cannot be any UINT or SINT format.</p>				
gather4 gather4_po (load4)		<p>Note: If Surface Format is a UINT or SINT format without alpha channel, and Gather4 Source Channel Select is alpha channel, the returned value, which should be 1, is incorrect.</p>				
gather4 gather4_po (load4)		<p>Note: Selecting green on R32G32_float has some erratic behavior:</p> <ul style="list-style-type: none"> gather4 only on this resource returns an erroneous value if alpha is selected. gather4 + other sample operations on this resource produce erratic output. 				



Message Type	Project	Description or Restriction
gather4 gather4_po (load4)	HSW	Note: offu/offv are calculated in normalized space and hence subject to small truncation error.
gather4_c gather4_po_c		<p>The Surface Type of the associated surface must be SURFTYPE_2D or SURFTYPE_CUBE. If the message type is gather4_po_c, only SURFTYPE_2D is allowed.</p> <p>The Surface Format of the associated surface must be one of the following: R32_FLOAT_X8X24_TYPELESS, R32_FLOAT, R24_UNORM_X8_TYPELESS, or R16_UNORM.</p> <p>The channel selected is determined by the Gather4 Source Channel Select field in the message header.</p> <p>Mip Mode Filter must be set to MIPFILTER_NONE.</p> <p>Use of gather4_c or gather4_po_c with DX9 Border Color Mode and either of the following is underfined:</p> <ul style="list-style-type: none"> Any applicable Address Control Mode (depending on Surface Type) is set to TEXCOORDMODE_CLAMP_BORDER or TEXCOORDMODE_HALF_BORDER. Surface Type is SURFTYPE_CUBE and any Cube Face Enable is disabled. <p>Number of Multisamples on the associated surface must be MULTISAMPLECOUNT_1.</p>
gather4_c gather4_po_c		The surface is sampled using bilinear filtering, regardless of the filtering mode specified in the sampler state. For SURFTYPE_2D, LOD is forced to zero before sampling. The samples are not filtered, but instead the four samples are returned, after being compared with the ref parameter as in the sample_c message. Each texel is replaced with either white or black depending on the result of the comparison. The four samples are returned in the sample's corresponding four channels in the same mapping as the gather4 message. The offu and offv parameters in the gather4_po_c message cause offset override behavior as described in the gather4 message.
gather4_c gather4_po_c		Note: offu/offv are calculated in normalized space and hence subject to small truncation error.
sample_unorm		<p>The surface is sampled using the indicated sampler state. 32 contiguous pixels in a 8-wide by 4-high arrangement are sampled. The U and V addresses for the upper left pixel are delivered in this message along with a Delta U and Delta V parameter. Given a pixel at (x,y) relative to the upper left pixel (where (0,0) is the upper left pixel), the U and V for that pixel are computed as follows:</p> $U(x,y) = U(0,0) + \text{DeltaU} * x$ $V(x,y) = V(0,0) + \text{DeltaV} * y$ <p>The Surface Type of the associated surface must be SURFTYPE_2D.</p> <p>The Surface Format of the associated surface must be UNORM with ≤ 8 bits per channel.</p> <p>The MIP Count, Depth, Surface Min LOD, Resource Min LOD, and Min Array Element of the associated surface must be 0.</p> <p>The Min and Mag Mode Filter must be MAPFILTER_NEAREST or MAPFILTER_LINEAR.</p> <p>The Mip Mode Filter must be MIPFILTER_NONE.</p>



Message Type	Project	Description or Restriction
		<p>The TCX and TCY Address Control Mode cannot be any of:</p> <p>TEXCOORDMODE_CLAMP_BORDER TEXCOORDMODE_HALF_BORDER TEXCOORDMODE_MIRROR TEXCOORDMODE_MIRROR_ONCE TEXCOORDMODE_WRAP</p> <p>DeltaU * Width of the associated surface must be less than or equal to 3.0.</p> <p>DeltaV * Height of the associated surface must be less than or equal to 3.0.</p> <p>Number of Multisamples on the associated surface must be MULTISAMPLECOUNT_1.</p>
sample_unorm_R G		
sample_unorm_R G +killpix		
sample_unorm +killpix		<p>This message is identical to the sample_unorm message except it returns a kill pixel mask in addition to the selected channels in the writeback message. This message type is required to allow the result of a chroma key enabled sampler in KEYFILTER_KILL_ON_ANY_MATCH mode to affect the final pixel mask. All restrictions of the sample_unorm message apply to this message also.</p>
sample_8x8		<p>The surface is sampled using an optional 8x8 filter, using state defined in SAMPLER_STATE and SAMPLER_8x8_STATE.</p> <p>The input consists of 64 contiguous pixels in a 16-wide by 4-high arrangement. The address control mode behaves as clamp mode. The U and V addresses for the upper left pixel are delivered in this message along with a Delta U and Delta V parameter. Given a pixel at (x,y) relative to the upper left pixel (where (0,0) is the upper left pixel), the U and V for that pixel are computed as follows:</p> $U(x,y) = U(0,0) + \text{DeltaU} * x + U_{2^{\text{nd}}_Derivative} * x * (x - 1)/2$ $V(x,y) = V(0,0) + \text{DeltaV} * y + V_{2^{\text{nd}}_Derivative} * y * (y - 1)/2$ <p>The Surface Type of the associated surface must be SURFTYPE_2D.</p> <p>The Surface Format of the associated surface must be UNORM with <= 10 bits per channel.</p> <p>DeltaV * Height of the associated surface must be less than 16.0.</p> <p>Map Width must be >= 4.</p>

Parameter Types

sample*, LOD, and gather4 messages

For all of the sample*, LOD, and gather4 message types, all parameters are 32-bit floating point, except the 'mcs', 'offu', and 'offv' parameters. Usage of the u, v, and r parameters is as follows based on **Surface Type**. Normalized values range from [0,1] across the surface, with values outside the surface behaving as specified by the **Address Control Mode** in that dimension. Unnormalized values range from [0,n-1]



across the surface, where n is the size of the surface in that dimension, with values outside the surface being clamped to the surface.

Surface Type	u	v	r	ai
SURFTYPE1D	normalized 'x' coordinate	unnormalized array index	ignored	ignored
SURFTYPE_2D	normalized 'x' coordinate	normalized 'y' coordinate	unnormalized array index	ignored
SURFTYPE_3D	normalized 'x' coordinate	normalized 'y' coordinate	normalized 'z' coordinate	ignored
SURFTYPE_CUBE	normalized 'x' coordinate	normalized 'y' coordinate	normalized 'z' coordinate	unnormalized array index

Project:	
mcs parameter	
The 'mcs' parameter delivers the multisample control data. The format of this parameter is always a 32-bit unsigned integer. Refer to the section titled "Multisampled Surface Behavior" for details on this parameter.	

Ld* messages

For the Ld message types, all parameters are 32-bit unsigned integers, except the 'mcs' parameter. Usage of the u, v, and r parameters is as follows based on **Surface Type**. Unnormalized values range from [0,n-1] across the surface, where n is the size of the surface in that dimension. Input of any value outside of the range returns zero.

Surface Type	u	v	r
SURFTYPE1D	unnormalized 'x' coordinate	unnormalized array index	ignored
SURFTYPE_2D	unnormalized 'x' coordinate	unnormalized 'y' coordinate	unnormalized array index
SURFTYPE_3D	unnormalized 'x' coordinate	unnormalized 'y' coordinate	unnormalized 'z' coordinate
SURFTYPE_BUFFER	unnormalized 'x' coordinate	ignored	ignored



Writeback Message

Corresponding to the four input message definitions are four writeback messages. Each input message generates a corresponding writeback message of the same type (SIMD16, SIMD8, SIMD4x2, or SIMD32/64).

SIMD16

Return Format = 32-bit

A SIMD16 writeback message consists of up to 8 destination registers. Which registers are returned is determined by the write channel mask received in the corresponding input message. Each asserted write channel mask results in both destination registers of the corresponding channel being skipped in the writeback message, and all channels with higher numbered registers being dropped down to fill in the space occupied by the masked channel. For example, if only red and alpha are enabled, red is sent to $regid+0$ and $regid+1$, and alpha to $regid+2$ and $regid+3$. The pixels written within each destination register is determined by the execution mask on the "send" instruction.

DWord	Bit	Description
W0.7	31:0	Subspan 1, Pixel 3 (lower right) Red: Specifies the value of the pixel's red channel. Format = IEEE Float, S31 signed 2's comp integer, or U32 unsigned integer. Format depends on the Data Return Format programmed for the surface being sampled.
W0.6	31:0	Subspan 1, Pixel 2 (lower left) Red
W0.5	31:0	Subspan 1, Pixel 1 (upper right) Red
W0.4	31:0	Subspan 1, Pixel 0 (upper left) Red
W0.3	31:0	Subspan 0, Pixel 3 (lower right) Red
W0.2	31:0	Subspan 0, Pixel 2 (lower left) Red
W0.1	31:0	Subspan 0, Pixel 1 (upper right) Red
W0.0	31:0	Subspan 0, Pixel 0 (upper left) Red
W1.7	31:0	Subspan 3, Pixel 3 (lower right) Red
W1.6	31:0	Subspan 3, Pixel 2 (lower left) Red
W1.5	31:0	Subspan 3, Pixel 1 (upper right) Red
W1.4	31:0	Subspan 3, Pixel 0 (upper left) Red
W1.3	31:0	Subspan 2, Pixel 3 (lower right) Red
W1.2	31:0	Subspan 2, Pixel 2 (lower left) Red
W1.1	31:0	Subspan 2, Pixel 1 (upper right) Red
W1.0	31:0	Subspan 2, Pixel 0 (upper left) Red
W2		Subspans 1 and 0 of Green: See W0 definition for pixel locations



DWord	Bit	Description
W3		Subspans 3 and 2 of Green: See W1 definition for pixel locations
W4		Subspans 1 and 0 of Blue: See W0 definition for pixel locations
W5		Subspans 3 and 2 of Blue: See W1 definition for pixel locations
W6		Subspans 1 and 0 of Alpha: See W0 definition for pixel locations
W7		Subspans 3 and 2 of Alpha: See W1 definition for pixel locations
W8.7:1		Reserved (not written): W8 is only delivered when Pixel Fault Mask Enable is enabled.
W8.0	31:16	Reserved: always written as 0xffff
	15:0	Pixel Null Mask: This field has the bit for all pixels set to 1 except those pixels in which a null page was source for at least one texel.

Return Format = 16-bit

DWord	Bit	Description
W0.7	31:16	Subspan 3, Pixel 3 (lower right) Red: Specifies the value of the pixel's red channel. Format = IEEE Half Float, S15 signed 2's comp integer, or U16 unsigned integer. Format depends on the Surface Format programmed for the surface being sampled.
	15:0	Subspan 3, Pixel 2 (lower left) Red
W0.6	31:16	Subspan 3, Pixel 1 (upper right) Red
	15:0	Subspan 3, Pixel 0 (upper left) Red
W0.5	31:16	Subspan 2, Pixel 3 (lower right) Red
	15:0	Subspan 2, Pixel 2 (lower left) Red
W0.4	31:16	Subspan 2, Pixel 1 (upper right) Red
	15:0	Subspan 2, Pixel 0 (upper left) Red
W0.3	31:16	Subspan 1, Pixel 3 (lower right) Red
	15:0	Subspan 1, Pixel 2 (lower left) Red
W0.2	31:16	Subspan 1, Pixel 1 (upper right) Red
	15:0	Subspan 1, Pixel 0 (upper left) Red
W0.1	31:16	Subspan 0, Pixel 3 (lower right) Red
	15:0	Subspan 0, Pixel 2 (lower left) Red
W0.0	31:16	Subspan 0, Pixel 1 (upper right) Red
	15:0	Subspan 0, Pixel 0 (upper left) Red
W1		Green: See W0 definition for pixel locations



W2		Blue: See W0 definition for pixel locations
W3		Alpha: See W0 definition for pixel locations
W4.7:1		Reserved (not written): W8 is only delivered when Pixel Fault Mask Enable is enabled.
W4.0	31:16	Reserved: always written as 0xffff
	15:0	Pixel Null Mask: This field has the bit for all pixels set to 1 except those pixels in which a null page was source for at least one texel.

SIMD8/SIMD8D

Return Format = 32-bit

This writeback message consists of four registers, or five in the case of sample+killpix. As opposed to the SIMD16 writeback message, channels that are masked in the write channel mask are not skipped, all four channels are always returned. The masked channels, however, are not overwritten in the destination register.

For the sample+killpix message types, an additional register (W4) is included after the last channel register.

DWord	Bits	Description
W0.7	31:0	Subspan 1, Pixel 3 (lower right) Red: Specifies the value of the pixel's red channel. Format = IEEE Float, S31 signed 2's comp integer, or U32 unsigned integer. Format depends on the Data Return Format programmed for the surface being sampled.
W0.6	31:0	Subspan 1, Pixel 2 (lower left) Red
W0.5	31:0	Subspan 1, Pixel 1 (upper right) Red
W0.4	31:0	Subspan 1, Pixel 0 (upper left) Red
W0.3	31:0	Subspan 0, Pixel 3 (lower right) Red
W0.2	31:0	Subspan 0, Pixel 2 (lower left) Red
W0.1	31:0	Subspan 0, Pixel 1 (upper right) Red
W0.0	31:0	Subspan 0, Pixel 0 (upper left) Red
W1		Subspans 1 and 0 of Green: See W0 definition for pixel locations
W2		Subspans 1 and 0 of Blue: See W0 definition for pixel locations
W3		Subspans 1 and 0 of Alpha: See W0 definition for pixel locations
W4.7:1		Reserved (not written) : This W4 is only delivered for the sample+killpix message type
W4.0	31:16	Dispatch Pixel Mask: This field is always 0xffff to allow dword-based ANDing with the R0 header in the pixel shader thread.



DWord	Bits	Description
	15:0	Active Pixel Mask: This field has the bit for all pixels set to 1 except those pixels that have been killed as a result of chroma key with kill pixel mode. Since the SIMD8 message applies to only 8 pixels, only the low 8 bits within this field are used. The high 8 bits are always set to 1.
W4.7:1		Reserved (not written): This W4 is only delivered when Pixel Fault Mask Enable is enabled.
W4.0	31:8	Reserved: always written as 0xfffff
	7:0	Pixel Null Mask: This field has the bit for all pixels set to 1 except those pixels in which a null page was source for at least one texel.

Return Format = 16-bit

DWord	Bits	Description
W0.7:4		Reserved
W0.3	31:16	Subspan 1, Pixel 3 (lower right) Red: Specifies the value of the pixel's red channel. Format = IEEE Half Float, S15 signed 2's comp integer, or U16 unsigned integer. Format depends on the Surface Format programmed for the surface being sampled.
	15:0	Subspan 1, Pixel 2 (lower left) Red
W0.2	31:16	Subspan 1, Pixel 1 (upper right) Red
	15:0	Subspan 1, Pixel 0 (upper left) Red
W0.1	31:16	Subspan 0, Pixel 3 (lower right) Red
	15:0	Subspan 0, Pixel 2 (lower left) Red
W0.0	31:16	Subspan 0, Pixel 1 (upper right) Red
	15:0	Subspan 0, Pixel 0 (upper left) Red
W1		Subspans 1 and 0 of Green: See W0 definition for pixel locations
W2		Subspans 1 and 0 of Blue: See W0 definition for pixel locations
W3		Subspans 1 and 0 of Alpha: See W0 definition for pixel locations
W4.7:1		Reserved (not written): This W4 is only delivered when Pixel Fault Mask Enable is enabled.
W4.0	31:8	Reserved: always written as 0xfffff
	7:0	Pixel Null Mask: This field has the bit for all pixels set to 1 except those pixels in which a null page was source for at least one texel.

SIMD4x2

A SIMD4x2 writeback message always consists of a single message register containing all four channels of each of the two "pixels" (called "samples" here, as they are not really pixels) of data. The write channel mask bits as well as the execution mask on the "send" instruction are used to determine which of the channels in the destination register are overwritten. If any of the four execution mask bits for a sample is asserted, that sample is considered to be active. The active channels in the write channel mask will be written in the destination register for that sample. If the sample is inactive (all four execution mask bits deasserted), none of the channels for that sample will be written in the destination register.



DWord	Bit	Description
W0.7	31:0	Sample 1 Alpha: Specifies the value of the pixel's alpha channel. Format = IEEE Float, S31 signed 2's comp integer, or U32 unsigned integer. Format depends on the Data Return Format programmed for the surface being sampled.
W0.6	31:0	Sample 1 Blue
W0.5	31:0	Sample 1 Green
W0.4	31:0	Sample 1 Red
W0.3	31:0	Sample 0 Alpha
W0.2	31:0	Sample 0 Blue
W0.1	31:0	Sample 0 Green
W0.0	31:0	Sample 0 Red
W1.7:1		Reserved (not written) : W4 is only delivered when Pixel Fault Mask Enable is enabled.
W1.0	31:2	Reserved: always written as 0x3fffffff
	1:0	Pixel Null Mask: This field has the bit for all samples set to 1 except those pixels in which a null page was source for at least one texel.

Shared Functions – Data Port

The Data Port provides all memory accesses for the Gen subsystem other than those provided by the sampling engine. These include render target writes, constant buffer reads, scratch space reads/writes, and media surface accesses.

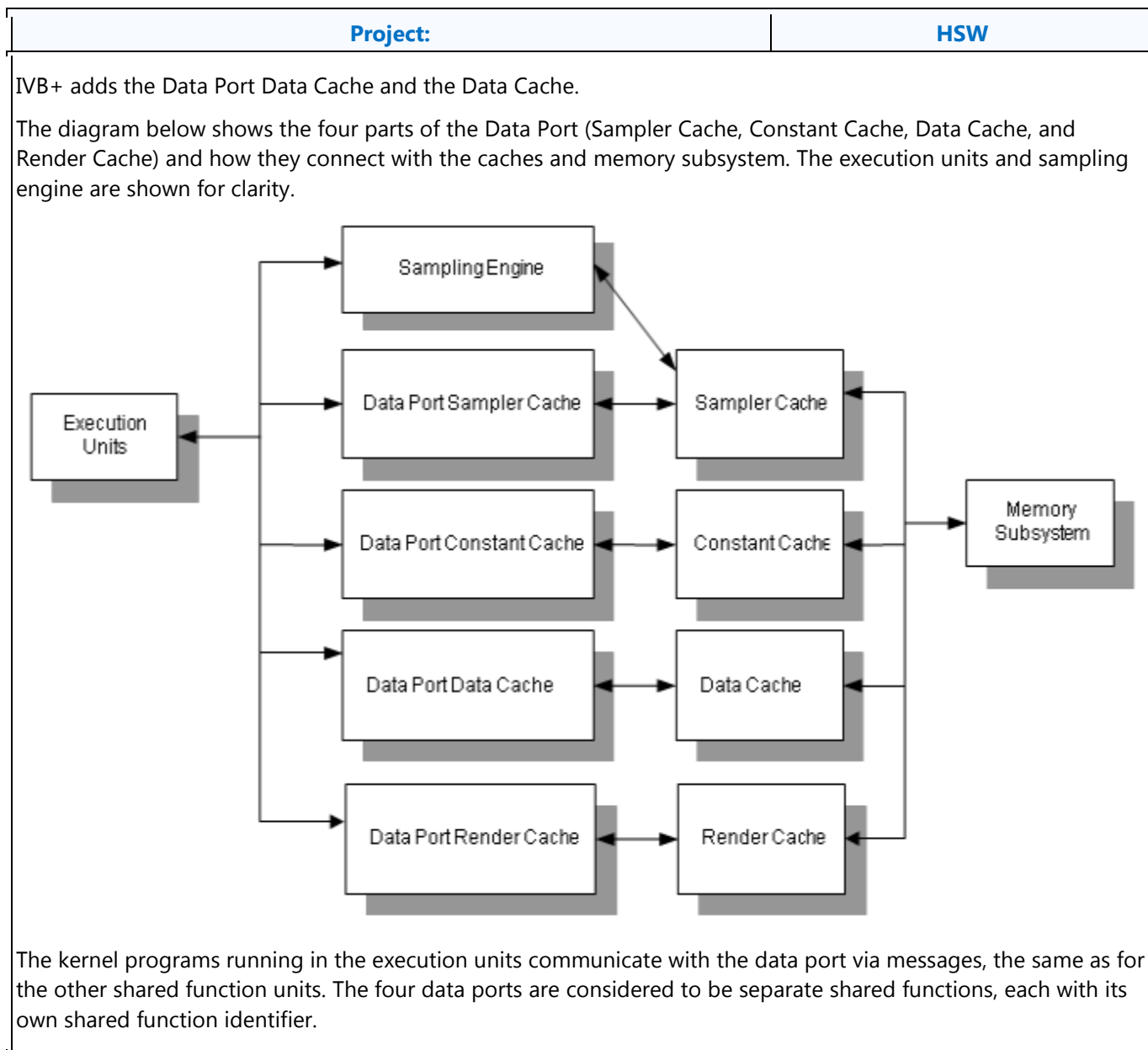



Data Cache

The data cache is a read/write cache that is coherent across the physical instances of this cache. It is intended to be used for the following surfaces:

- constant buffers
- destination surfaces for media applications
- intermediate working surfaces for media applications
- scratch space buffers
- general read/write access of surfaces
- atomic operations
- shared memory for GPGPU thread groups

The data cache can be accessed via the *Data Cache Data Port* shared function, and via the load and store EU messages. Ordering from a single thread is maintained when accessing the data cache using only one of these mechanisms, but is not maintained when using both of these mechanisms from the same thread. In these instances, software must ensure ordering by using write commits and/or waiting for read data to be returned.



Sampler Cache

The sampler cache is a read-only cache that supports both linear and tiled memory. In addition to being used by the sampling engine (via the sampling engine messages), the sampler cache is intended to be used for source surfaces in media applications via the data port. The same application may use the sampler cache via the sampling engine and data port without flushing the pipeline between accesses.



Surfaces

The data elements accessed by the data port are called "surfaces". There are two models used by the data port to access these surfaces: surface state model and stateless model.

Surface State Model

The data port uses the binding table to bind indices to surface state, using the same mechanism used by the sampling engine. The surface state model is used when a **Binding Table Index** (specified in the message descriptor) of less than 255 is specified. In this model, the **Binding Table Index** is used to index into the binding table, and the binding table entry contains a pointer to the SURFACE_STATE. SURFACE_STATE contains the parameters defining the surface to be accessed, including its location, format, and size.

This model is intended to be used for constant buffers, render target surfaces, and media surfaces.

Stateless Model

The stateless model is used when a **Binding Table Index** (specified in the message descriptor) of 255 is specified.

This model is primarily intended to be used for scratch space buffers.

In this model, the binding table is not accessed, and the parameters that define the surface state are overloaded as follows:

- Surface Type = SURFTYPE_BUFFER
- Surface Format = R32G32B32A32_FLOAT
- Vertical Line Stride = 0
- Surface Base Address = General State Base Address + Immediate Base Address
- Surface Pitch = 16 bytes
- Utilize Fence = false
- Tiled = false

Buffer Size Checking

Project	Buffer Size Checking
	Buffer Size = checked only against General State Access Upper Bound When General State Access Upper Bound is zero, no bounds checking is performed.



Shared Local Memory (SLM)

The shared local memory (SLM) is a high bandwidth memory that is not backed up by system memory. It is enabled by configuring the L3 cache to use a portion of its space for the SLM. One SLM is present in each half slice, and its contents are shared between all of the active threads in that half slice. Its contents are uninitialized after creation, and its contents disappear when deallocated.

The SLM is accessed when a **Binding Table Index** (specified in the message descriptor) of 254 is specified. The binding table is not accessed, and the parameters that define the surface state are overloaded as follows:

- Surface Type = SURFTYPE_BUFFER
- Surface Format = RAW
- Surface Base Address = points to the start of the internal SLM (no memory address is applicable)
- Surface Pitch = 1 byte

Due to the predefined surface state attributes for the SLM, only a subset of the data port messages can be used. This includes the Byte Scattered Read/Write, Untyped Surface Read/Write, and Untyped Atomic Operation messages. In addition, only the data cache data port is supported; the other data ports treat Binding Table Index 254 as a normal surface state access.

Programming Note: Accesses to SLM don't have any bounds checking. Addresses beyond the size (64KB) of the SLM wrap around.



Write Commit

For write messages, an optional write commit writeback message can be requested via the Send Write Commit Message bit in the message descriptor. This bit causes a return message to the thread indicating when the write has been committed to the in-order cache pipeline and it is safe to issue another access to the same data with the assurance that it will happen after the first write. A read issued after the write commit ensures that the read will get the newly written data, and another write issued after the write commit will be the last to modify the data. "Committed" does not guarantee that the data has been actually written to the memory subsystem, but only that the write has been scheduled and cannot be passed by another read or write issued subsequently.

If **Send Write Commit Message** is used on a Flush Render Cache message, the write commit is sent only when the render cache has completed its flush to memory. A read issued to another cache after the write commit is received will be guaranteed to retrieve the "new" data that was written before the Flush Render Cache message was issued.

The write commit does not modify the destination register, but merely clears the dependency associated with the destination register. Thus, a simple "mov" instruction using the register as a source is sufficient to wait for the write commit to occur. The following code sequence indicates this:

```
send r12 m1 DPWRITE      ; Issue write to render cache.
mov m1 r3                ; Assemble read message.
mov r12 r12              ; Block on write commit.
send r13 m1 DPREAD      ; Read same location as write.
```



Read/Write Ordering

Reads and writes issued from the same thread *are* guaranteed to be processed in the same order as issued. Software mechanisms must still ensure any needed ordering of accesses issued from different threads.



Accessing Buffers

There are four data port messages used to access buffers. Three of these are used for both constant buffers and scratch space buffers, the fourth is used by the geometry shader kernel to write to streamed vertex buffers. All of these messages support only buffers, and can use the surface state model as well as the stateless model.

The following table indicates the intended applications of each of the buffer messages.

Message	Applications
OWord Block Read/Write	<ul style="list-style-type: none">constant buffer reads of a single constant or multiple contiguous constantsscratch space reads/writes where the index for each pixel/vertex is the sameblock constant reads, scratch memory reads/writes for media
OWord Dual Block Read/Write	<ul style="list-style-type: none">SIMD4x2 constant buffer reads where the indices of each vertex/pixel are different (if there are two indices and they are the same, hardware will optimize the cache accesses and do only one cache access)SIMD4x2 scratch space reads/writes where the indices are different.
DWord Scattered Read/Write	<ul style="list-style-type: none">SIMD8/16 constant buffer reads where the indices of each pixel are different (read one channel per message)SIMD8/16 scratch space reads/writes where the indices are different (read/write one channel per message)general purpose DWord scatter/gathering, used by media
Streamed Vertex Buffer Write	<ul style="list-style-type: none">geometry shader streaming vertex data out

These messages generally ignore the surface format field of the state and perform no format conversion. The exception is the Streamed Vertex Buffer Write, which uses the surface format field to determine only how many channels are to be written. The data contained in each channel is still not converted in any way.



Accessing Media Surfaces

The Media Block Read/Write message is intended to be used to access 2D media surfaces. The message specifies an X/Y coordinate into the 2D surface as input. Since this message only supports 2D surfaces, the stateless model cannot be used with this message.

Boundary Behavior

The table below summarizes the behavior of the **Media Boundary Pixel Mode** field (SURFACE_STATE) in combination with the **Vertical Line Stride** and **Vertical Line Stride Offset** fields (both of which are subject to being overridden by the Data Port message descriptor fields). The Behavior column illustrates behavior for a surface with four rows numbered 0 to 3. The bold indicators are off-surface behavior and the non-bold indicators are on-surface behavior. Input row addresses range from -3 to +7 going left to right.

Media Boundary Pixel Mode	Vertical Line Stride	Vertical Line Stride Offset	Usage Model	Behavior
0	0	X	normal frame	000001233333
0	1	0	normal field even	000002222222
0	1	1	normal field odd	111113333333
2	0	X	frame / progressive	000001233333
2	1	0	field even / progressive	000002333333
2	1	1	field odd / progressive	000013333333
3	0	X	frame / interlaced	010101232323
3	1	0	field even / interlaced	000002222222
3	1	1	field odd / interlaced	111113333333



State

BINDING_TABLE_STATE

The data port uses the binding table to retrieve surface state. Refer to [State](#) in the Sampling Engine section for the definition of this state.

SURFACE_STATE

The data port uses the surface state for constant buffers, render targets, and media surfaces.



Messages

Global Definitions

For data port messages, part of the message descriptor is used to determine the message type. This field is documented here. The remainder of the message descriptor is defined differently depending on the message type, and is documented in the section for the corresponding message.

The Data Port is actually separate targets, **Data Port**, **Sampler Cache**, **Data Port Constant Cache**, and **Data Port Render Cache**, each with its own target unit ID. Each target has its own set of message type encodings as shown below.

Note: Data port messages may not have the **End of Thread** bit set in the message descriptor other than the following exceptions:

- The Render Target Write message may have **End of Thread** set for pixel shader threads dispatched by the windower in non-contiguous dispatch mode.
- The Render Target UNORM Write message may have **End of Thread** set for pixel shader threads dispatched by the windower in contiguous dispatch mode.
- The Media Block Write message may have **End of Thread** set for pixel shader threads dispatched by the windower in contiguous dispatch mode.

Data Port Messages

Most of the messages have an existing definition that is not expected to change. There are several new messages that are documented here.

Data Cache Data Port Message Summary

Project	Message Type	Header Required	Shared Local Memory Support	Stateless Support	Address Modes	Vector Width
	OWord Block Read	yes	no	yes	global	1
	OWord Block Write	yes	no	yes	global	1
	Unaligned OWord Block Read	yes	no	yes	global	1
	OWord Dual Block Read	no for stated yes for stateless	no	yes	global + offset	2
	OWord Dual Block Write	no for stated yes for	no	yes	global + offset	2



Project	Message Type	Header Required	Shared Local Memory Support	Stateless Support	Address Modes	Vector Width
		stateless				
	DWord Scattered Read	no for stated yes for stateless	no	yes	global + offset	8, 16
	DWord Scattered Write	no for stated yes for stateless	no	yes	global + offset	8, 16
	Byte Scattered Read	no for stated yes for stateless	yes	yes	global + offset	8, 16
	Byte Scattered Write	no for stated yes for stateless	yes	yes	global + offset	8, 16
	Untyped Surface Read	no for stated yes for stateless	yes	yes (1D only)	1D or 2D	2, 8, 16
	Untyped Surface Write	no for stated yes for stateless	yes	yes (1D only)	1D or 2D	2, 8, 16
	Untyped Atomic Operation	no for stated yes for stateless	yes	yes (1D only)	1D or 2D	8, 16
	Untyped Atomic Operation SIMD4x2	no for stated yes for stateless	yes	yes (1D only)	1D or 2D	2
	Atomic Counter Operation	no ² Required for inc, dec, predec	no	no	implied	8, 16
	Atomic Counter Operation SIMD4x2	no ² Required for inc, dec, predec	no	no	implied	2



Project	Message Type	Header Required	Shared Local Memory Support	Stateless Support	Address Modes	Vector Width
	Scratch Block Read	yes	no	yes (only)	Imm_Buf + offset	
	Scratch Block Write	yes	no	yes (only)	Imm_Buf + offset	
	Memory Fence	yes	N/A	N/A	N/A	N/A
	Typed Surface Read	yes	no	no	1D, 2D, 3D, 4D	2, 8
	Typed Surface Write	yes	no	no	1D, 2D, 3D, 4D	2, 8
	Typed Atomic Operation	yes	no	no	1D, 2D, 3D, 4D	8
	Typed Atomic Operation SIMD4x2	yes	no	no	1D, 2D, 3D, 4D	2, 8
	Media Block Read	yes	no	no	2D	1
	Media Block Write	yes	no	no	2D	1

Table Notes

"global" is the **Global Offset** in the message header (if header is not present, Global Offset is zero).

"imm_buf" is the Immediate Buffer Base Address provided in message header register M0.5.

"offset" is in the message payload, and is per-slot.

"handle" is the handle address in the message header.

"URBoffset" is the **Global Offset** field in the URB message descriptor.

"1D" and "2D" are the address payload.



Project:

Note ² in the table above: **Note:** For Atomic Counter OPS other than INC, DEC, and PREDEC, the header is forbidden and not optional as indicated in the table.

Project:

HSW

Render Cache Data Port Message Summary

Message Type	Header Required	Address Modes	Vector Width
Media Block Read (legacy)	yes	2D	1
Media Block Write (non-IECP)	yes	2D	1
Render Target Write	no	2D + RTAI	8, 16
Memory Fence	yes	N/A	N/A

Message Descriptor

DATA PORT SAMPLER CACHE		DATA PORT CONSTANT CACHE		DATA PORT RENDER CACHE	
Bit	Description	Bit	Description	Bit	Description
19	Header Present. If set, indicates that the message includes the header. Refer to Render Target Write message section for more details on this field. Programming Notes: The header must be present unless the message type is Render Target Write Format = Enable				
18	Ignored				
17:16	Ignored	17:16	Ignored	17	Send Write Commit Message. Indicates that a write commit message will be sent back to the thread when the write has been committed. See section <i>Write Commit</i> for more details. This field is ignored on read message types. Format = Enable
15:13	Message Type 000: OWord Block Read 010: OWord Dual Block Read 100: Media Block Read	15:13	Message Type 000: OWord Block Read 010: OWord Dual Block Read 110: DWord Scattered Read	16:13	Message Type 0000: OWord Block Read 0001: Render Target UNORM Read 0010: OWord Dual Block Read 0100: Media Block Read 0101: Unaligned OWord Block Read



	101: Unaligned OWord Block Read 110: DWord Scattered Read All other encodings are reserved.		All other encodings are reserved.		0110: DWord Scattered Read 0111: DWord Atomic write message 1000: OWord Block Write 1001: OWord Dual Block Write 1010: Media Block Write 1011: DWord Scattered Write 1100: Render Target Write 1101: Streamed Vertex Buffer Write 1110: Render Target UNORM Write All other encodings are reserved.
12:8	Message Specific Control. Refer to the specific message section for the definition of these bits.				
7:0	Binding Table Index. Specifies the index into the binding table for the specified surface. A binding table index of 255 indicates that a stateless model is to be used. The stateless model is allowed only with the render cache data port. Refer to section 2.2.2 for details on the stateless model. Format = U8 Range = [0,255]				

Message Descriptor

SAMPLER CACHE DATA PORT		RENDER CACHE DATA PORT	
Bit	Description	Bit	Description
19	Header Present. If set, indicates that the message includes the header. Programming Notes: For the Render cache Data Port, the header must be present for the following message types: Memory Fence Media block read Media block write For 3d RT reads and writes, header is optionally present. For the Sampler Cache Data Port, the header must be present for the following message types: Unaligned OWord Block Read Media block read Format = Enable		



SAMPLER CACHE DATA PORT		RENDER CACHE DATA PORT	
Bit	Description	Bit	Description
18	Ignored	18	Ignored
17:14	Message Type 0000: Read Surface Info 0001: Unaligned OWord Block Read 0100: Media Block Read All other encodings are reserved.	17:14	Message Type 0100: Media Block Read (legacy) 0111: Memory Fence 1010: Media Block Write (non-IECP) 1100: Render Target Write All other encodings are reserved.
13:8	Message Specific Control. Refer to the specific message section for the definition of these bits.		
7:0	Binding Table Index. Specifies the index into the binding table for the specified surface. Format = U8 Range = [0,255]		

CONSTANT CACHE DATA PORT		DATA CACHE DATA PORT0		DATA CACHE DATA PORT1	
Bit	Description	Bit	Description	Bit	Description
19	<p>Header Present. If set, indicates that the message includes the header.</p> <p>Programming Notes:</p> <p>For the Data Cache Data Port*, the header must be present for the following message types:</p> <ul style="list-style-type: none"> OWord Block Read/Write Unaligned OWord Block Read Memory Fence Scratch read/write Typed read/write/atomics Media block read/write <p>For the Constant Cache Data Port, the header must be present for the following message types:</p> <ul style="list-style-type: none"> OWord Block Read/Write Unaligned OWord Block Read <p>Format = Enable</p>				
18	Ignored	18	Category 1: Scratch Block Read/Write messages	18	Ignored



CONSTANT CACHE DATA PORT		DATA CACHE DATA PORT0		DATA CACHE DATA PORT1	
Bit	Description	Bit	Description	Bit	Description
			0: Legacy DAP-DC messages		
17:14	Message Type 0000: OWord Block Read 0001: Unaligned OWord Block Read 0010: OWord Dual Block Read 0011: DWord Scattered Read All other encodings are reserved.	17:14	Category=0 (legacy dataport) Message Type 0000: OWord Block Read 0001: Unaligned OWord Block Read 0010: OWord Dual Block Read 0011: DWord Scattered Read 0100: Byte Scattered Read 0111: Memory Fence 1000: OWord Block Write 1010: OWord Dual Block Write 1011: DWord Scattered Write 1100: Byte Scattered Write All other encodings are reserved. Category=1 (scratch) [17]: 0=Read; 1=write [16]:Type; 0=Oword, 1= Dword [15]:Invalidate after read; [14]:<Reserved, mbz> [13:12]: Block Size 11: 4 registers 10: <reserved> 01: 2 registers 00: 1 register [11:0]: Addr offset (Hword based)	17:14	Message Type 0001: Untyped Surface Read 0010: Untyped Atomic Operation 0011: Untyped Atomic Operation SIMD4x2 0100: Media Block Read 0101: Typed Surface Read 0110: Typed Atomic Operation 0111: Typed Atomic Operation SIMD4x2 1001: Untyped Surface Write 1010: Media Block Write (non-IECP) 1011: Atomic Counter Operation 1100: Atomic Counter Operation SIMD4x2 1101: Typed Surface Write All other encodings are reserved.
13:8	Message Specific Control. Refer to the specific message section for the definition of these bits.				
7:0	Binding Table Index. Specifies the index into the binding table for the specified surface.				



CONSTANT CACHE DATA PORT		DATA CACHE DATA PORT0		DATA CACHE DATA PORT1	
Bit	Description	Bit	Description	Bit	Description
	For the data cache data port, two binding table indexes are used to select special surfaces: 254: A binding table index of 254 indicates that the shared local memory (SLM) is to be used. The SLM is only supported with the Byte Scattered Read/Write, Untyped Surface Read/Write, and Untyped Atomic Operation messages. Refer to the "Shared Local Memory" section earlier in this chapter for further details on its behavior. 255: A binding table index of 255 indicates that a stateless model is to be used. Refer to section "Stateless Model" section for details on the stateless model. 253: An alias for Stateless 252: An alias for Stateless 251: An alias for Stateless 250: An alias for Stateless Format = U8 Range = [0,255]				

[DevHSW+] SFID_DP_DC1 is an extension of SFID_DP_DC0 to allow for more message types. They act as a single logical entity.

The stateless aliases provide a means of SW controlling the coherency properties of an access. The property is ensured for that access only. Typically, SW will use the same coherency type for all access to the same address. Proper fencing is required to ensure that reads and writes are visible. L3UC forces the addressed cache lines out of L3 and the cycles are directly conducted to LLC. This provides a capability for ensuring coherency on a particular location without having to fence all the other cycles.

Binding table index		
255	Locally Coherent	Coherent within a thread group
253	Non-Coherent	Coherent within a thread
252	Globally Coherent	Coherent within Gen
251	LLC Coherent	Coherent within the package
250	L3UC	Uncachable in L3

Programming Restriction: When using BTI = 253, SW must ensure that 2 threads do not both access the same cache line (64B).

Programming Note: If the stateless access falls between the **LLC Coherent Base Address** and the **LLC Coherent Upper bound** and the BTI is not equal to 250, then the access will be forced to take on the LLC coherent attribute and behave accordingly.

Notes: Binding table indexes 250-253 are not implemented. SW should treat these as reserved and have the binding table for these entries point to a surface state of type SURFTYPE_NULL.



Message Header

This header applies to the following data port messages:

Project	Data Port Message
	OWord Block Read/Write
	Unaligned OWord Block Read
	OWord Dual Block Read/Write
	DWord Scattered Read/Write
	Byte Scattered Read/Write
	Scratch Block Read/Write

The header definitions for the other data port messages is in the section for each message.

DWord	Bits	Description	Project	Security
M0.5	31:10	Immediate Buffer Base Address. Specifies the surface base address for messages in which the Binding Table Index is 255 (stateless model), else this field is ignored. This pointer is relative to the General State Base Address . Format = GeneralStateOffset[31:10]		
	9:8	Ignored		
	7:0	Dispatch ID. This ID is assigned by the fixed function unit and is a unique identifier for the thread. It is used to free up resources used by the thread upon thread completion.		
M0.4	31:0	Ignored (reserved for hardware delivery of binding table pointer)		
M0.3	31:4	Ignored		
	3:0	Per Thread Scratch Space Specifies the amount of scratch space allowed to be used by this thread for messages in which the Binding Table Index is 255 (stateless model), else this field is ignored. Programming Notes: This amount is available to the kernel for information only. It is passed verbatim (if not altered by the kernel) to the Data Port in any scratch space access messages. The data port uses this to bounds check scratch space messages. Writes out of bounds are ignored. Reads out of bounds return 0. Format = U4 Range = [0,11] indicating [1K bytes, 2M		



DWord	Bits	Description	Project	Security
		bytes] in powers of two.		
M0.2	31:0	<p>Global Offset.</p> <p>Specifies the global element offset into the buffer.</p> <p>For the Unaligned OWord messages, this offset is in units of Bytes but must be DWord-aligned (bits 1:0 MBZ).</p> <p>For the other OWord messages, this offset is in units of OWords.</p> <p>For the DWord messages, this offset is in units of DWords.</p> <p>For the Byte messages, this offset is in units of Bytes.</p> <p>Format = U32</p> <p>Range = [0,FFFFFFFFCh] for Unaligned OWord messages.</p> <p>Range = [0,0FFFFFFFFh] for other OWord messages.</p> <p>Range = [0,3FFFFFFFFh] for DWord messages.</p> <p>Range = [0,FFFFFFFFh] for Byte messages.</p>		
M0.1	31:0	Ignored		
M0.0	31:0	Ignored		

Write Commit Writeback Message

The writeback message is only sent on Data Port Write messages if the **Send Write Commit Message** bit in the message descriptor is set. The destination register is not modified. Write messages without the **Send Write Commit Message** bit set will not return anything to the thread (response length is 0 and destination register is null).

DWord	Bit	Description
W0.7:0		Reserved

OWord Block ReadWrite

This message takes one offset (Global Offset), and reads or writes 1, 2, 4, or 8 contiguous OWords starting at that offset.



Restrictions

Project	Restriction
	The only surface type allowed is SURFTYPE_BUFFER.
	The surface format is ignored; data is returned from the constant buffer to the GRF without format conversion.
	The surface is treated as a 1-dimensional surface. The element size (pitch) times the number of elements is used to determine the size of the buffer for out-of-bounds checking if using the surface state model. Out of bounds checking is done at DWord granularity; if any part of a DWord is out-of-bounds then the whole DWord is considered out-of-bounds.
	The surface cannot be tiled.
	The surface base address must be OWord-aligned.
	The Render Cache Read Write Mode field in SURFACE_STATE must be set to read/write mode when using this message with the render cache in the surface state model.
	The Stateless Render Cache Read-Write Mode field in the SVG_WORK_CTL register must be set to read/write mode when using this message with the render cache in the stateless model.

Applications:

- Constant buffer reads of a single constant or multiple contiguous constants.
- Scratch space reads/writes where the index for each pixel/vertex is the same.
- Block constant reads, scratch memory reads/writes for media.

Execution Mask. The low 8 bits of the execution mask are used to enable the 8 channels in the first and third GRF registers returned (W0, W2) for read, or the first and third write registers sent (M1, M3). The high 8 bits are used similarly for the second and fourth registers (W1, W3 or M2, M4). For reads, any mask bit set within a group of four causes the entire OWord to be read and returned to the destination GRF register. For writes, each mask bit is considered for its corresponding DWord written to the destination surface.

For the 1-OWord messages, only the low 8 bits of the execution mask are used. Either the low 4 bits or the high 4 bits, depending on the position of the OWord to be read or written, are used as the single group of four with behavior following that in the preceding paragraph.

The above behavior enables a SIMD16 thread to use the 8-OWord form of this message to access two channels (red and green) of a single scratch register across 16 pixels. A second message would access the other two channels (blue and alpha). The execution mask is used to ensure that data associated with inactive pixels are not overwritten.

Out-of-Bounds Accesses. Reads to areas outside of the surface return 0. Writes to areas outside of the surface are dropped and do not modify memory.

Message Descriptor

Project	Bits	Description
---------	------	-------------



Project	Bits	Description
	13	<p>Invalidate After Read Enable. This field, if enabled, causes all lines in the L3 cache accessed by the message to be invalidated after the read occurs, regardless of whether the line contains modified data. It is intended as a performance hint indicating that the data will no longer be used to avoid writing back data to memory. This field is ignored for write messages.</p> <p>Enabling this field is intended for scratch and spill/fill, where the memory is used only by a single thread and thus does not need to be maintained after the thread completes.</p> <p>Format = Enable</p>
	12	Ignored
	11	Ignored
	10:8	<p>Block Size. Specifies the number of contiguous OWords to be read or written</p> <p>000: 1 OWord, read into or written from the low 128 bits of the destination register.</p> <p>001: 1 OWord, read into or written from the high 128 bits of the destination register.</p> <p>010: 2 OWords</p> <p>011: 4 OWords</p> <p>100: 8 OWords</p> <p>All other encodings are reserved.</p> <p>Programming Note: The 6 OWord block size is valid only with Data Port Constant Cache.</p>

Message Payload (Write)

For the write operation, the message payload consists of one, two, or four registers (not including the header) depending on the **Block Size** specified in the message. For the one-constant case, data is taken from either the high or low half of the payload register depending on the half selected in **Block Size**. In this case, the other half of the payload register is ignored.

The **Offset** referred to below is the **Global Offset** and is in units of OWords. The **OWord** array index is also in units of OWords.

DWord	Bits	Description
M1.7:4	127:0	OWord[Offset + 1]. If the block size is 1, OWord to be written from the high 128 bits of the destination, OWord[Offset] will appear in this location.
M1.3:0	127:0	OWord[Offset]
M2.7:4	127:0	OWord[Offset+3]
M2.3:0	127:0	OWord[Offset+2]
M3.7:4	127:0	OWord[Offset+5]



DWord	Bits	Description
M3.3:0	127:0	OWord[Offset+4]
M4.7:4	127:0	OWord[Offset+7]
M4.3:0	127:0	OWord[Offset+6]

Writeback Message (Read)

For the read operation, the writeback message consists of one, two, three, or four registers depending on the **Block Size** specified in the message. For the one-constant case, data is placed in either the high or low half of the returned register depending on the half selected in **Block Size**. In this case, the other half of the register is not changed.

The **Offset** referred to below is the **Global Offset** and is in units of OWords. The **OWord** array index is also in units of OWords.

DWord	Bits	Description
W0.7:4	127:0	OWord[Offset + 1] . If the block size is 1, OWord to be loaded into the high 128 bits of the destination, OWord[Offset] will appear in this location.
W0.3:0	127:0	OWord[Offset]
W1.7:4	127:0	OWord[Offset+3]
W1.3:0	127:0	OWord[Offset+2]
W2.7:4	127:0	OWord[Offset+5]
W2.3:0	127:0	OWord[Offset+4]
W3.7:4	127:0	OWord[Offset+7]
W3.3:0	127:0	OWord[Offset+6]

Unaligned OWord Block Read

This message takes one DWord aligned offset (**Global Offset**), and reads 1, 2, 4, or 8 contiguous OWords starting at that offset. This message is identical to the OWord Block Read message except for the offset alignment. For read/write cache, only the read path supports this unaligned OWord Block access.

Restrictions

Project	Restriction
	The only surface type allowed is SURFTYPE_BUFFER.
	The surface format is ignored; data is returned from the constant buffer to the GRF without format conversion.
	The surface is treated as a 1-dimensional surface. The element size (pitch) times the number of elements is used to determine the size of the buffer for out-of-bounds checking if using the surface state model. Out of bounds checking is done at DWord granularity; if any part of a DWord is out-of-bounds then the whole DWord is considered out-of-bounds.
	The surface cannot be tiled.



Project	Restriction
	The surface base address must be OWord-aligned.
	The Render Cache Read Write Mode field in SURFACE_STATE must be set to read/write mode when using this message with the render cache in the surface state model.
	The Stateless Render Cache Read-Write Mode field in the SVG_WORK_CTL register must be set to read/write mode when using this message with the render cache in the stateless model.

Applications: Reads with an offset that is not aligned with data size, such as row store usage in media.

Execution Mask. The execution mask is ignored by this message.

Out-of-Bounds Accesses. Reads to areas outside of the surface return 0.

Message Descriptor

Project	Bits	Description
	13	Ignored
	12:11	Ignored
	10:8	<p>Block Size. Specifies the number of contiguous OWords to be read.</p> <p>000: 1 OWord, read into the low 128 bits of the destination register.</p> <p>001: 1 OWord, read into the high 128 bits of the destination register.</p> <p>010: 2 OWords.</p> <p>011: 4 OWords.</p> <p>100: 8 OWords.</p> <p>All other encodings are reserved.</p>

Writeback Message (Read)

For the read operation, the writeback message consists of one, two, or four registers depending on the **Block Size** specified in the message. For the one-constant case, data is placed in either the high or low half of the returned register depending on the half selected in **Block Size**. In this case, the other half of the register is not changed.

The **Global Offset** is in units of **Bytes**, aligned to **DWord** (two LSBs set to zero). The **OWordX** array in units of OWord starts at Global Offset.

DWord	Bit	Description
W0.7:4	127:0	OWord1 = $*(&OWord0 + 1)$. If the block size is 1 OWord to be loaded into the high 128 bits of the destination, OWord0 will appear in this location
W0.3:0	127:0	OWord0 = Buffer[Global Offset]
W1.7:4	127:0	OWord3 = $*(&OWord2 + 1)$



DWord	Bit	Description
W1.3:0	127:0	OWord2 = *(&OWord1 + 1)
W2.7:4	127:0	OWord5 = *(&OWord4 + 1)
W2.3:0	127:0	OWord4 = *(&OWord3 + 1)
W3.7:4	127:0	OWord7 = *(&OWord6 + 1)
W3.3:0	127:0	OWord6 = *(&OWord5 + 1)

OWord Dual Block ReadWrite

This message takes two offsets, and reads or writes 1 or 4 contiguous OWords starting at each offset. The Global Offset is added to each of the specific offsets.

Project:	HSW
The message header is no longer required for the <i>OWord Dual Block Read/Write</i> messages if sent to the data cache data port. If header is not sent, the Global Offset field is assumed to be zero. The header is required, however, if the binding table index is 255 (stateless model), as the Immediate Buffer Base Address field is required.	

Programming Restriction: Writes to overlapping addresses have undefined write ordering.

Restrictions

Project	Restriction
	The only surface type allowed is SURFTYPE_BUFFER.
	The surface format is ignored; data is returned from the constant buffer to the GRF without format conversion.
	The surface is treated as a 1-dimensional surface. The element size (pitch) times the number of elements is used to determine the size of the buffer for out-of-bounds checking if using the surface state model. Out of bounds checking is done at DWord granularity; if any part of a DWord is out-of-bounds then the whole DWord is considered out-of-bounds.
	The surface cannot be tiled.
	The surface base address must be OWord-aligned.
	The Render Cache Read Write Mode field in SURFACE_STATE must be set to read/write mode when using this message with the render cache in the surface state model.
	The Stateless Render Cache Read-Write Mode field in the SVG_WORK_CTL register must be set to read/write mode when using this message with the render cache in the stateless model.

Applications:

- SIMD4x2 constant buffer reads where the indices of each vertex/pixel are different (if there are two indices and they are the same, hardware will optimize the cache accesses and do only one cache access).



- SIMD4x2 scratch space reads/writes where the indices are different.

Execution Mask. The low 8 bits of the execution mask are used to enable the 8 channels in the GRF registers returned for read, or each of the write registers sent. For reads, any mask bit asserted within a group of four will cause the entire OWord to be read and returned to the destination GRF register. For writes, each mask bit is considered for its corresponding DWord written to the destination surface.

Out-of-Bounds Accesses. Reads to areas outside of the surface return 0. Writes to areas outside of the surface are dropped and do not modify memory contents.

Message Descriptor

Project	Bits	Description
	13	<p>Invalidate After Read Enable. This field, if enabled, causes all lines in the L3 cache accessed by the message to be invalidated after the read occurs, regardless of whether the line contains modified data. It is intended as a performance hint indicating that the data will no longer be used to avoid writing back data to memory. This field is ignored for write messages.</p> <p>Enabling this field is intended for scratch and spill/fill, where the memory is used only by a single thread and thus does not need to be maintained after the thread completes.</p> <p>Format = Enable</p>
	12:10	Ignored
	9:8	<p>Block Size. Specifies the number of OWords in each block to be read or written:</p> <p>00: 1 OWord</p> <p>10: 4 OWords</p> <p>All other encodings are reserved.</p>

Message Payload

DWord	Bits	Description
M1.7	31:0	Ignored
M1.6	31:0	Ignored
M1.5	31:0	Ignored
M1.4	31:0	Block Offset 1. Specifies the OWord offset of OWord Block 1 into the surface. Format = U32 Range = [0,0FFFFFFh]
M1.3	31:0	Ignored
M1.2	31:0	Ignored
M1.1	31:0	Ignored
M1.0	31:0	Block Offset 0



Additional Message Payload (Write)

For the write operation, the message payload consists of one or four registers (not including the header or the first part of the payload) depending on the **Block Size** specified in the message.

The **Offset1/0** referred to below is the **Global Offset** added to the corresponding **Block Offset 1/0** and is in units of OWords. The **OWord** array index is also in units of OWords.

DWord	Bit	Description
M2.7:4	127:0	OWord[Offset1]
M2.3:0	127:0	OWord[Offset0]
M3.7:4	127:0	OWord[Offset1+1]
M3.3:0	127:0	OWord[Offset0+1]
M4.7:4	127:0	OWord[Offset1+2]
M4.3:0	127:0	OWord[Offset0+2]
M4.7:4	127:0	OWord[Offset1+3]
M4.3:0	127:0	OWord[Offset0+3]

Writeback Message (Read)

For the read operation, the writeback message consists of one or four registers depending on the **Block Size** specified in the message.

The **Offset1/0** referred to below is the **Global Offset** added to the corresponding **Block Offset 1/0** and is in units of OWords. The **OWord** array index is also in units of OWords.

DWord	Bits	Description
W0.7:4	127:0	OWord[Offset1]
W0.3:0	127:0	OWord[Offset0]
W1.7:4	127:0	OWord[Offset1+1]
W1.3:0	127:0	OWord[Offset0+1]
W2.7:4	127:0	OWord[Offset1+2]
W2.3:0	127:0	OWord[Offset0+2]
W3.7:4	127:0	OWord[Offset1+3]
W3.3:0	127:0	OWord[Offset0+3]

Media Block Read/Write

The read form of this message enables a rectangular block of data samples to be read from the source surface and written into the GRF. The write form enables data from the GRF to be written to a rectangular block.



Restrictions

Project	Restriction
	The only surface type allowed is non-arrayed, non-mipmapped SURFTYPE_2D. Because of this, the stateless surface model is not supported with this message.
	The surface format is used to determine the pixel structure for boundary clamp; the raw data from the surface is returned to the thread without any format conversion nor filtering operation.
	The target cache cannot be the data cache.
	The surface base address must be 32-byte aligned.
	When a surface is XMajor tiled, (tilewalk field in the surface state is set to TILEWALK_XMAJOR), a memory area mapped through the Render Cache cannot be read and/or written in mixed frame and field modes. For example, if a memory location is first written with a zero Vertical Line Stride (frame mode), and later on (without render cache flush) read back using Vertical Line Stride of one (field mode), the read data stored in the GRF are uncertain.
	The block width and offset should be aligned to the size of pixels stored in the surface. For a surface with 8bpp pixels for example, the block width and offset can be byte-aligned. For a surface with 16bpp pixels, it is word-aligned.
	For YUV422 formats, the block width and offset must be pixel pair aligned (i.e. DWord-aligned).
	The write form of this message has the additional restriction that both X Offset and Block Width must be DWord-aligned.
	Pitch must be a multiple of 64 bytes when the surface is linear.

Applications: Block reads/writes for media.

Execution Mask. The execution mask on the *send* instruction for this type of message is ignored. The data that is read or written is determined completely by the block parameters.

Out-of-Bounds Accesses. Reads outside of the surface results in the address being clamped to the nearest edge of the surface and the pixel in the position being returned. Writes outside of the surface are dropped and will not modify memory contents.

Determining the boundary pixel value depends on the surface format. Surface format definitions can be found in the Surface Formats Section of the Sampling Engine Chapter.

For a surface with 8bpp pixels, the boundary byte is replicated. For example, for a boundary DWord B0B1B2B3, to replicate the left boundary byte pixel, the out of bound DWords have the format B0B0B0B0, and the format for the right boundary is B3B3B3B3.

This rule applies to all surface formats with BPE of 8. As the data port does not perform format conversion, the most likely used surface formats are R8_UINT and R8_SINT.

For any other surfaces with 16bpp pixels, boundary pixel replication is on words. For example, for a boundary dword B0B1B2B3, to replicate the left boundary word pixel, the out of bound DWords have the format B0B1B0B1, and the format for the right boundary is B2B3B2B3.

This rule applies to all surface formats with BPE of 16. As the data port does not perform format conversion, only the formats with integer data types may be useful in practice.



For special surfaces with 16bpp pixels YUV422 packed format, there are two basic cases depending on the Y location: YUYV (surface format YCRCB_NORMAL) and UYVY (surface format YCRCB_SWAPY). Boundary handling for YVYU (surface format YCRCB_SWAPUV) is the same as that for YUYV. Similarly, boundary handling for VYUY (surface format YCRCB_SWAPUVY) is the same as that for UYVY. Note that these four surface formats have 16bpp pixels, even though the BPE fields are set to zero according to the table in the Surface Formats Section.

For a boundary DWord Y0U0Y1V0, to replicate the left boundary, we get Y0U0**Y0V0**, and to replicate the right boundary, we get **Y1**U0Y1V0.

For a boundary DWord U0Y0V0Y1, to replicate the left boundary, we get U0Y0V0**Y0**, and to replicate the right boundary, we get U0**Y1**V0Y1.

For a surface with 32bpp pixels, the boundary DWord pixel is replicated.

This rule applies to all surface formats with BPE of 32. As the data port does not perform format conversion, some of the formats may not be useful in practice.

Hardware behavior for any other surface types is undefined.

When Color Processing Enable is set to 1 and the IECP output surface to be written is NV12 format (R16_UNORM surface format 0x10A, should be used if the output surface is NV12 format).

NV12 surface state: The width of the surface should be always multiples of 4 pixels. For 16bpp input message (422 8-bit) the width will always need to be in multiples of 8 bytes and for 32bpp input message (422 16-bit or 444 8-bit) the width should be in multiples of 16 bytes. Height should be in multiples of 2 pixels high. (Presently the MFX restriction is that width should be in multiples of 2 pixels.)

The y-offset of the media block write from the EU should always be even.

The x-offset of the media block write from the EU should be in multiples of 4 pixels.

The media block DWord write can have only the following combinations (for IECP when NV12 output format is used):

- 8 pixels wide for 422 8-bit mode
- 4 pixels wide for 422 8-bit mode
- 4 pixels wide for 422 16-bit
- 4 pixels wide for 444 8-bit
- 444 16-bit input format cannot be supported when the output format is NV12 (SW should not use this combination).
- It has to be in multiples of 2 pixels high for all above modes.

If 444-format is used then we use only the pixel_0 UV values of the 2x2 pixel and the rest are dropped and in case of 422-format the top UV values are used and the bottom UV values are dropped if the output format is NV12 format.

Assuming IECP messages will always have vertical stride = 0 (since this is only for pre-processing before the encoder).



Message Descriptor

Project	Bit	Description															
	13	Reserved: MBZ															
	12	Reserved: MBZ															
	11	Reserved: MBZ															
	10	<p>Vertical Line Stride Override</p> <p>Specifies whether the Vertical Line Stride and Vertical Line Stride Offset fields in the surface state should be replaced by bits 9 and 8 below.</p> <p>If this field is 1, Height in the surface state (see SURFACE_STATE section of Sampling Engine chapter) is modified according the following rules:</p> <table border="1"> <thead> <tr> <th>Vertical Line Stride (in surface state)</th> <th>Override Vertical Line Stride</th> <th>Derived 1-based Surface Height (As a function of the 0-based Height in Surface State)</th> </tr> </thead> <tbody> <tr> <td>0</td> <td>0</td> <td>Height + 1 (Normal)</td> </tr> <tr> <td>0</td> <td>1</td> <td>(Height + 1) / 2 Restriction: (Height + 1) must be an even number.</td> </tr> <tr> <td>1</td> <td>0</td> <td>(Height + 1) * 2</td> </tr> <tr> <td>1</td> <td>1</td> <td>Height + 1 (Normal)</td> </tr> </tbody> </table> <p>For example, for a 720x480 standard resolution video buffer, if Vertical Line Stride in surface state is 0, i.e. a frame, Height (of the frame) should be 479. When accessing the bottom field of this frame video buffer, if both Override Vertical Line Stride and Override Vertical Line Stride Offset are set to 1, then the derived surface height (of the field) is 240 ((Height + 1) / 2). In contrast, if Vertical Line Stride in surface state is 1 and Vertical Line Stride Offset in surface state is 0, the surface state represents the top field of the video buffer. In this case, Height (of the top field) should be programmed as 239. Accessing the bottom video field uses the same surface height of 240. Accessing the video frame (with Override Vertical Line Stride and Override Vertical Line Stride Offset of 0) results in a derived surface height of 480 ((Height + 1) * 2).</p> <p>0: Use parameters in the surface state and ignore bits 9:8.</p> <p>1: Use bits 9:8 to provide the Vertical Line Stride and Vertical Line Stride Offset.</p>	Vertical Line Stride (in surface state)	Override Vertical Line Stride	Derived 1-based Surface Height (As a function of the 0-based Height in Surface State)	0	0	Height + 1 (Normal)	0	1	(Height + 1) / 2 Restriction: (Height + 1) must be an even number.	1	0	(Height + 1) * 2	1	1	Height + 1 (Normal)
Vertical Line Stride (in surface state)	Override Vertical Line Stride	Derived 1-based Surface Height (As a function of the 0-based Height in Surface State)															
0	0	Height + 1 (Normal)															
0	1	(Height + 1) / 2 Restriction: (Height + 1) must be an even number.															
1	0	(Height + 1) * 2															
1	1	Height + 1 (Normal)															
	9	Override Vertical Line Stride															



Project	Bit	Description
		Specifies number of lines (0 or 1) to skip between logically adjacent lines – provides support of interleaved (field) surfaces as textures. Format = U1 in lines to skip between logically adjacent lines.
	8	Override Vertical Line Stride Offset Specifies the offset of the initial line from the beginning of the buffer. Ignored when Override VerticalLine Stride is 0. Format = U1 in lines of initial offset (when Vertical Line Stride == 1).

Message Header

DWord	Bits	Description	Project	Security
M0.5	31:8	Ignored		
	7:0	FFTID. This ID is assigned by the fixed function unit and is a unique identifier for the thread. It is used to free up resources used by the thread upon thread completion.		
M0.4	31:0	Ignored (reserved for hardware delivery of binding table pointer)		
M0.3	31:5	Color Processing State Pointer. Defines the pointer to COLOR_PROCESSING_STATE. Ignored on read messages and when Color Processing Enable is not set. This pointer is relative to the General State Base Address . Programming Note: This pointer is <i>not</i> delivered via state variables like most other pointers are delivered. It must be delivered via another software-defined mechanism such as CURBE. Format = GeneralStateOffset[31:5]		
	4	Message Mode. This field selects the mode of this message as follows: 0: NORMAL. The Block Height and Block Width fields are set in M0.2. The Pixel Mask is not explicitly set but behaves as if it is set to all ones. 1: PIXEL_MASK. The Pixel Mask field is set in M0.2. The Block Height and Block Width are not explicitly set but behave as if they are set to 4 rows and 32 bytes, respectively. Programming Note: Only NORMAL mode is allowed for Block width > 32 bytes. For the <i>Sampler Cache Data Port</i> , this field is also ignored, behaving as if always set to NORMAL.		



DWord	Bits	Description	Project	Security
	3:2	Ignored		
	1	Area of Interest. This field controls whether the statistic for the luma pixels is collected at VSC for ACE histogram. This field is effective only when the state variable Full_image_histogram is disabled.		
	0	Ignored		
The following M0.2 definition applies only if the Message Mode field is set to NORMAL:				
M0.2	31:29	Ignored		
	28:24	<p>Sub-Register Offset. This field provides the sub-register offset in unit of byte of a media block read message. This field is ignored (reserved) for a media block write message.</p> <p>Programming Notes:</p> <p>Sub-Register Offset must be aligned to BasePitch (therefore will be a multiple of DWords as well).</p> <p>When Register Pitch Control = 0, Sub-Register Offset must align to BasePitch*Block Height and the output fits in a single GRF register.</p> <p>In general (and specifically when Sub-Register Offset is greater than 0), when the resulting data cross a GRF register boundary, the data must be placed symmetrically between GRF registers.</p> <p>Sub-Register Offset and Register Pitch Control allow software to assemble multiple media block reads directly into a shared GRF register set. For example, if both are set to zero, the read data are written to GRF registers, aligning to the least significant bits of the first register, and the register pitch is equal to the next power-of-2 that is greater than or equal to the Block Width. If Register Pitch Control is non-zero, multiple media block read messages sharing the same Register Pitch Control but with different Sub-Register Offset can fill in the same set of GRF registers with media block data line interleaved.</p> <p>This field must be zero for Render Cache Data Port.</p> <p>Format = U5</p> <p>Range = [0, 28] (Only a multiple of BasePitch, including 0, is valid.)</p>		
	21:16	<p>Block Height. Height in rows of block being accessed.</p> <p>Programming Note: The Block Height is restricted to the following maximum values depending on the Block Width:</p>		



DWord	Bits	Description	Project	Security										
		<table border="1"> <thead> <tr> <th>Block Width (bytes)</th> <th>Maximum Block Height (rows)</th> </tr> </thead> <tbody> <tr> <td>1-4</td> <td>64</td> </tr> <tr> <td>5-8</td> <td>32</td> </tr> <tr> <td>9-16</td> <td>16</td> </tr> <tr> <td>17-32</td> <td>8</td> </tr> </tbody> </table> <p>Format = U6 Range = [0,63] representing 1 to 64 rows</p>	Block Width (bytes)	Maximum Block Height (rows)	1-4	64	5-8	32	9-16	16	17-32	8		
Block Width (bytes)	Maximum Block Height (rows)													
1-4	64													
5-8	32													
9-16	16													
17-32	8													
	15:10	Ignored												
	9:8	<p>Register Pitch Control This field controls the register pitch for a media block read message. This field is ignored (reserved) for a media block write message.</p> <p>Programming Notes:</p> <p>This field must be zero for Render Cache Data Port.</p> <p>Register Pitch Control is only allowed to be non-zero, if Block Width is a multiple of DWords. The effective register pitch must be less than or equal to 32 bytes (to fit in a single GRF register).</p> <p>Defining BasePitch as the next power-of-2 that is greater than or equal to the Block Width, Register Pitch Control set the register pitch in term of BasePitch as the following:</p> <p>Range = [0,3] representing 1 to 4 BasePitch</p>												
	7:5	Ignored												
	4:0	<p>Block Width. Width in bytes of the block being accessed.</p> <p>Programming Note: Must be DWord-aligned for the write form of the message.</p> <p>Range = [0,31] representing 1 to 32 bytes</p>												
The following M0.2 definition applies only if the Message Mode field is set to PIXEL_MASK:														
MO.2	31:0	<p>Pixel Mask. One bit per pixel (each pixel being a DWord) indicating which pixels are to be written. This field is ignored by the read message, all pixels are always returned.</p> <p>The bits in this mask correspond to the pixels (DWords) as follows:</p>												



DWord	Bits	Description	Project	Security																																
		<table border="1"> <tr><td>0</td><td>1</td><td>4</td><td>5</td><td>16</td><td>17</td><td>20</td><td>21</td></tr> <tr><td>2</td><td>3</td><td>6</td><td>7</td><td>18</td><td>19</td><td>22</td><td>23</td></tr> <tr><td>8</td><td>9</td><td>12</td><td>13</td><td>24</td><td>25</td><td>28</td><td>29</td></tr> <tr><td>10</td><td>11</td><td>14</td><td>15</td><td>26</td><td>27</td><td>30</td><td>31</td></tr> </table>	0	1	4	5	16	17	20	21	2	3	6	7	18	19	22	23	8	9	12	13	24	25	28	29	10	11	14	15	26	27	30	31		
0	1	4	5	16	17	20	21																													
2	3	6	7	18	19	22	23																													
8	9	12	13	24	25	28	29																													
10	11	14	15	26	27	30	31																													
M0.1	31:0	<p>Y offset. The Y offset of the upper left corner of the block into the surface.</p> <p>Format = S31</p> <p>Programming Note: If Message Mode is set to PIXEL_MASK, this field must be a multiple of 4.</p>																																		
M0.0	31:0	<p>X offset. The X offset of the upper left corner of the block into the surface.</p> <p>Must be DWord-aligned (Bits 1:0 MBZ) for the write form of the message.</p> <p>The X offset field defines the offset in the input message block. This may differ from the offset in the surface if Color Processing is enabled due to format conversion.</p> <p>Format = S31</p> <p>Programming Note: If Message Mode is set to PIXEL_MASK, this field must be a multiple of 32.</p>																																		

Programming Note: The legal combinations of block width, pitch control, sub-register offset, and block height are given below:

Block Height for given block width, pitch control, subreg offsets									
block width	pitch control	sub-register offsets							
		0	1	2	3	4	5	6	7
1-4	00	1-64	1	1	1	1	1	1	1
	01	1-64	1-64	illegal	illegal	1-2	1-2	illegal	illegal
	10	illegal	illegal	illegal	illegal	illegal	illegal	illegal	illegal
	11	1-64	1-64	1-64	1-64	illegal	illegal	illegal	illegal
5-8	00	1-32	illegal	1	illegal	1	illegal	1	illegal
	01	1-32	illegal	1-32	illegal	illegal	illegal	illegal	illegal
	10	illegal	illegal	illegal	illegal	illegal	illegal	illegal	illegal
	11	1-32	illegal	1-32	illegal	1-32	illegal	1-32	illegal
9-16	00	1-16	illegal	illegal	illegal	1	illegal	illegal	illegal
	01	1-16	illegal	illegal	illegal	1-16	illegal	illegal	illegal
	10	illegal	illegal	illegal	illegal	illegal	illegal	illegal	illegal



Block Height for given block width, pitch control, subreg offsets									
block width	pitch control	sub-register offsets							
		0	1	2	3	4	5	6	7
	11	1-16	illegal	illegal	illegal	1-16	illegal	illegal	illegal
7-32	00	1-8	illegal	illegal	illegal	illegal	illegal	illegal	illegal
	01	1-8	illegal	illegal	illegal	illegal	illegal	illegal	illegal
	10	illegal	illegal	illegal	illegal	illegal	illegal	illegal	illegal
	11	1-8	illegal	illegal	illegal	illegal	illegal	illegal	illegal

Message Payload (Write)

DWord	Bit	Description
M1:n		Write Data. The format of the write data depends on the Block Height and Block Width . The data is aligned to the least significant bits of the first register, and the register pitch is equal to the next power-of-2 that is greater than or equal to the Block Width .

If **Color Processing Enable** is enabled, the write data is divided into pixels according to the **Message Format** field. The fields within each pixel are defined below. For the 4:2:2 modes, each pixel position includes channels for two pixels.

Message Format	31:24	23:16	15:8	7:0
YUV 4:2:2, 8 bits per channel	Cr (V)	right pixel lum (Y1)	Cb (U)	left pixel lum (Y0)
YUV 4:4:4, 8 bits per channel	alpha (A)	luminance (Y)	Cb (U)	Cr (V)
	63:48	47:32	31:16	15:0
YUV 4:2:2, 16 bits per channel	Cr (V)	right pixel lum (Y1)	Cb (U)	left pixel lum (Y0)
YUV 4:4:4, 16 bits per channel	alpha (A)	Cr (V)	luminance (Y)	Cb (U)

Writeback Message (Read)

Project	DWord	Bits	Description
	W0:n	31:0	Read Data. The format of the read data depends on the Block Height , Block Width , Register Pitch Control , and Sub-Register Offset . The data is aligned to the Sub-Register Offset of the first register, and the register pitch is set to one or more BasePatch .

DWord Scattered ReadWrite

This message takes a set of offsets, and reads or writes 8 or 16 scattered DWords starting at each offset. The Global Offset is added to each of the specific offsets.



Restrictions

Project	Restriction
	The only surface type allowed is SURFTYPE_BUFFER.
	The surface format is ignored; data is returned from the constant buffer to the GRF without format conversion.
	The surface cannot be tiled.
	The surface base address must be DWord-aligned.
	Writes to overlapping addresses have undefined write ordering.
	For read messages with X/Y offsets that are outside the bounds of the surface, the address is clamped to the nearest edge of the surface. For write messages with X/Y offsets that are outside the bounds of the surface, the behavior is undefined.
	The Render Cache Read Write Mode field in SURFACE_STATE must be set to read/write mode when using this message with the render cache in the surface state model.
	The Stateless Render Cache Read-Write Mode field in the SVG_WORK_CTL register must be set to read/write mode when using this message with the render cache in the stateless model.
	Hardware does check for and optimize for cases where offsets are equal or contiguous, however for optimal performance in some of these cases a different message may provide higher performance.
	The message header is no longer required for the <i>OWord DWord Scattered Read/Write</i> messages if sent to the data cache data port. If header is not sent, the Global Offset field is assumed to be zero. The header is required, however, if the binding table index is 255 (stateless model), as the Immediate Buffer Base Address field is required.
	The surface is treated as a 1-dimensional surface. The element size (pitch) times the number of elements is used to determine the size of the buffer for out-of-bounds checking if using the surface state model. Out of bounds checking is done at a DWord granularity; if any part of the DWord is out-of-bounds then the whole DWord is considered out-of-bounds.

Applications:

- SIMD8/16 constant buffer reads where the indices of each pixel are different (read one channel per message)
- SIMD8/16 scratch space reads/writes where the indices are different (read/write one channel per message)
- General purpose DWord scatter/gathering, used by media

Execution Mask. Depending on the block size, either the low 8 bits or all 16 bits of the execution mask are used to determine which DWords are read into the destination GRF register (for read), or which DWords are written to the surface (for write).

Out-of-Bounds Accesses. Reads to areas outside of the surface return 0. Writes to areas outside of the surface are dropped and will not modify memory contents.



Message Descriptor

Project	Bits	Description
	13	Invalidate After Read Enable. If enabled, causes all lines in the L3 cache accessed by the message to be invalidated after the read occurs, regardless of whether the line contains modified data. It is intended as a performance hint indicating that the data will no longer be used to avoid writing back data to memory. This field is ignored for write messages. Enabling this field is intended for scratch and spill/fill, where the memory is used only by a single thread and thus does not need to be maintained after the thread completes. Format = Enable
	12	Ignored
	11:10	Ignored
	9:8	Block Size. Specifies the number of DWords read or written: 10: 8 DWords 11: 16 DWords All other encodings are reserved.



Message Payload

DWord	Bits	Description
M1.7	31:0	Offset 7. Specifies the DWord offset of DWord 7 into the surface. Format = U32 Range = [0,3FFFFFFh]
M1.6	31:0	Offset 6
M1.5	31:0	Offset 5
M1.4	31:0	Offset 4
M1.3	31:0	Offset 3
M1.2	31:0	Offset 2
M1.1	31:0	Offset 1
M1.0	31:0	Offset 0
M2.7	31:0	Offset 15. This message register is included only if the block size is 16 DWords.
M2.6	31:0	Offset 14
M2.5	31:0	Offset 13
M2.4	31:0	Offset 12
M2.3	31:0	Offset 11
M2.2	31:0	Offset 10
M2.1	31:0	Offset 9
M2.0	31:0	Offset 8



Additional Message Payload (Write)

For the write operation, either one or two additional registers (depending on the block size) of payload contain the data to be written.

The **Offset_n** referred to below is the **Global Offset** added to the corresponding **Offset n** and is in units of DWords. The **DWord** array index is also in units of DWords.

DWord	Bit	Description
M3.7	31:0	DWord[Offset7]
M3.6	31:0	DWord[Offset6]
M3.5	31:0	DWord[Offset5]
M3.4	31:0	DWord[Offset4]
M3.3	31:0	DWord[Offset3]
M3.2	31:0	DWord[Offset2]
M3.1	31:0	DWord[Offset1]
M3.0	31:0	DWord[Offset0]
M4.7	31:0	DWord[Offset15] . This message register is included only if the block size is 16 DWords
M4.6	31:0	DWord[Offset14]
M4.5	31:0	DWord[Offset13]
M4.4	31:0	DWord[Offset12]
M4.3	31:0	DWord[Offset11]
M4.2	31:0	DWord[Offset10]
M4.1	31:0	DWord[Offset9]
M4.0	31:0	DWord[Offset8]



Writeback Message (Read)

For the read operation, the writeback message consists of either one or two registers depending on the block size.

The **DWord** array index is also in units of DWords.

DWord	Bits	Description
W0.7	31:0	DWord[Offset7]
W0.6	31:0	DWord[Offset6]
W0.5	31:0	DWord[Offset5]
W0.4	31:0	DWord[Offset4]
W0.3	31:0	DWord[Offset3]
W0.2	31:0	DWord[Offset2]
W0.1	31:0	DWord[Offset1]
W0.0	31:0	DWord[Offset0]
W1.7	31:0	DWord[Offset15] . This writeback message register is included only if the block size is 16 DWords.
W1.6	31:0	DWord[Offset14]
W1.5	31:0	DWord[Offset13]
W1.4	31:0	DWord[Offset12]
W1.3	31:0	DWord[Offset11]
W1.2	31:0	DWord[Offset10]
W1.1	31:0	DWord[Offset9]
W1.0	31:0	DWord[Offset8]

Message Descriptor

Bit	Description
12	Two-Source Message. When this bit is set, there are two data-phases for two sources. Two-source message is used only for opcode "0111" and for all other opcodes this bit must be 0. When this bit is 0, M3 is not sent to the data-port.
11:8	Atomic Operation Code: (Please refer to the table below) Unsupported opcodes: 1101, 1110, 1111

Opcode	Operation	Return Value
0000	ADD: new = old + src0	Old value
0001	SUB: new = old – src0	Old value
0010	INC : new = old+1	Old value
0011	DEC: new = old-1	Old value



Opcode	Operation	Return Value
0100	MIN: new = min(old, src0)	Old value
0101	MAX: new = max(old, src0)	Old value
0110	XCHG: new = src0	Old value
0111	CMPXCHG : new = (old==src1) ? src0 : old	Old value
1000	AND: new = old & src0	Old value
1001	OR: new = old src0	Old value
1010	XOR: new = old ^ src0	Old value
1011	MIN_SINT: new = min(old, src0)	Old value(signed)
1100	MAX_SINT: new = max(old, src0)	Old value(signed)
1101-1111		Old value

Message Payload

DWord	Bit	Description
M1.7	31:0	Offset 7. Specifies the DWord offset of DWord 7 into the surface. Format = U32 Range = [0,3FFFFFFh]
M1.6	31:0	Offset 6
M1.5	31:0	Offset 5
M1.4	31:0	Offset 4
M1.3	31:0	Offset 3
M1.2	31:0	Offset 2
M1.1	31:0	Offset 1
M1.0	31:0	Offset 0



Source Payload

Either one or two additional registers (depending on **Two-Source Message**) of source payload contain the data to be used as source.

The **Offset_n** referred to below is the **Global Offset** added to the corresponding **Offset n** and is in units of DWords. The **DWord** array index is also in units of DWords.

DWord	Bit	Description
M2.7	31:0	DWord[Offset7] Src0
M2.6	31:0	DWord[Offset6] Src0
M2.5	31:0	DWord[Offset5] Src0
M2.4	31:0	DWord[Offset4] Src0
M2.3	31:0	DWord[Offset3] Src0
M2.2	31:0	DWord[Offset2] Src0
M2.1	31:0	DWord[Offset1] Src0
M2.0	31:0	DWord[Offset0] Src0
M3.7	31:0	DWord[Offset7] Src1
M3.6	31:0	DWord[Offset6] Src1
M3.5	31:0	DWord[Offset5] Src1
M3.4	31:0	DWord[Offset4] Src1
M3.3	31:0	DWord[Offset3] Src1
M3.2	31:0	DWord[Offset2] Src1
M3.1	31:0	DWord[Offset1] Src1
M3.0	31:0	DWord[Offset0] Src1



Writeback Message

For the read operation, the writeback message consists of either one or two registers depending on the block size.

The **Offset_n** referred to below is the **Global Offset** added to the corresponding **Offset n** and is in units of DWords. The **DWord** array index is also in units of DWords.

DWord	Bit	Description
W0.7	31:0	DWord[Offset7]
W0.6	31:0	DWord[Offset6]
W0.5	31:0	DWord[Offset5]
W0.4	31:0	DWord[Offset4]
W0.3	31:0	DWord[Offset3]
W0.2	31:0	DWord[Offset2]
W0.1	31:0	DWord[Offset1]
W0.0	31:0	DWord[Offset0]

Byte Scattered ReadWrite

These messages are supported on IVB+ only.

These messages take a set of offsets, and read or write 8 or 16 scattered and possibly misaligned bytes, words, or DWords starting at each offset. The **Global Offset** from the message header is added to each of the specific offsets.

Restrictions

Project	Restriction
	The only surface type allowed is SURFTYPE_BUFFER.
	The surface format is ignored; data is returned from the buffer to the GRF without format conversion.
	The surface cannot be tiled.
	The surface base address must be DWord-aligned.
	Writes to overlapping addresses have undefined write ordering.
	The surface is treated as a 1-dimensional surface. The element size (pitch) times the number of elements is used to determine the size of the buffer for out-of-bounds checking if using the surface state model. Out of bounds checking is done at DWord granularity; if any part of the DWord is out-of-bounds then the whole DWord is considered out-of-bounds.
	The stateless model is supported. Bounds checking for a stateless message is 4GB overflow and < General State upper bound.
	For byte scattered read and write the buffer size must be a multiple of 4 bytes.

Applications: Byte aligned buffer accesses in GPGPU programs.



Execution Mask. Depending on the block size, either the low 8 bits or all 16 bits of the execution mask are used to determine which slots are read into the destination GRF register (for read), or which slots are written to the surface (for write).

Out-of-Bounds Accesses. Reads to areas outside of the surface return 0. Writes to areas outside of the surface are dropped and will not modify memory contents.

Message Descriptor

Bit	Description
13:12	Ignored
11:10	<p>Data Size. Specifies the data size for each slot.</p> <p>0: 1 byte</p> <p>1: 2 bytes</p> <p>2: 4 bytes</p> <p>3: Reserved</p>
9	Ignored
8	<p>SIMD Mode. Specifies the SIMD mode of the message (number of slots processed).</p> <p>0: SIMD8</p> <p>1: SIMD16</p>

Message Payload

DWord	Bits	Description
M1.7	31:0	<p>Offset 7.</p> <p>Specifies the byte offset of DWord 7 into the surface.</p> <p>Format = U32</p> <p>Range = [0,FFFFFFFFh]</p>
M1.6	31:0	Offset 6
M1.5	31:0	Offset 5
M1.4	31:0	Offset 4
M1.3	31:0	Offset 3
M1.2	31:0	Offset 2
M1.1	31:0	Offset 1
M1.0	31:0	Offset 0
M2.7	31:0	<p>Offset 15. This message register is included only if the SIMD Mode is SIMD16.</p>



DWord	Bits	Description
M2.6	31:0	Offset 14
M2.5	31:0	Offset 13
M2.4	31:0	Offset 12
M2.3	31:0	Offset 11
M2.2	31:0	Offset 10
M2.1	31:0	Offset 9
M2.0	31:0	Offset 8

Additional Message Payload (Write)

For the write operation, either one or two additional registers (depending on the block size) of payload contain the data to be written.

The **Offset_n** referred to below is the **Global Offset** added to the corresponding **Offset n** and is in units of bytes. The length of **Data** written depends on the **Data Size** and is right-justified within the 32-bit field. The upper bits are ignored for 1 byte and 2 byte **Data Size**.

DWord	Bit	Description
M3.7	31:0	Data[Offset7]
M3.6	31:0	Data[Offset6]
M3.5	31:0	Data[Offset5]
M3.4	31:0	Data[Offset4]
M3.3	31:0	Data[Offset3]
M3.2	31:0	Data[Offset2]
M3.1	31:0	Data[Offset1]
M3.0	31:0	Data[Offset0]
M4.7	31:0	Data[Offset15] . This message register is included only if the SIMD Mode is SIMD16.
M4.6	31:0	Data[Offset14]
M4.5	31:0	Data[Offset13]
M4.4	31:0	Data[Offset12]
M4.3	31:0	Data[Offset11]
M4.2	31:0	Data[Offset10]
M4.1	31:0	Data[Offset9]
M4.0	31:0	Data[Offset8]



Writeback Message (Read)

For the read operation, the writeback message consists of either one or two registers depending on the block size.

The **Offset_n** referred to below is the **Global Offset** added to the corresponding **Offset n** and is in units of bytes. The length of **Data** written depends on the **Data Size** and is right-justified within the 32-bit field and only the requested bytes are written to the GRF.

DWord	Bit	Description
W0.7	31:0	Data[Offset7]
W0.6	31:0	Data[Offset6]
W0.5	31:0	Data[Offset5]
W0.4	31:0	Data[Offset4]
W0.3	31:0	Data[Offset3]
W0.2	31:0	Data[Offset2]
W0.1	31:0	Data[Offset1]
W0.0	31:0	Data[Offset0]
W1.7	31:0	Data[Offset15] . This message register is included only if the SIMD Mode is SIMD16.
W1.6	31:0	Data[Offset14]
W1.5	31:0	Data[Offset13]
W1.4	31:0	Data[Offset12]
W1.3	31:0	Data[Offset11]
W1.2	31:0	Data[Offset10]
W1.1	31:0	Data[Offset9]
W1.0	31:0	Data[Offset8]

TypedUntyped Surface ReadWrite and TypedUntyped Atomic Operation

Six data port messages (Typed Surface Read, Typed Surface Write, Typed Atomic Operation, Untyped Surface Read, Untyped Surface Write, and Untyped Atomic Operation) allow direct read/write accesses to surfaces. These messages support three major categories of surfaces:

- **Typed surfaces.** These surfaces are of type SURFTYPE_1D, 2D, 3D, or BUFFER and have a supported surface format other than RAW.

Project	Description
	Supported via the data cache data port.

Programming Restriction: The Vertical stride & Vertical Offset fields of the surface state object are only supported for 2D non-array surfaces.



- **Raw buffer (untyped).** These surfaces are of type SURFTYPE_BUFFER and have a surface format of RAW and a surface pitch of 1 byte. Supported via the data cache data port. All SLM accesses are in this category.
- **Structured buffer (untyped).** These surfaces are of type SURFTYPE_STRBUF and have a surface format of RAW. Supported via the data cache data port.

A typed surface uses U, V, R, and LOD address parameters (the number of parameters used depends on the surface type), and performs conversion of type to/from the selected surface format as follows:

- Surface formats with UINT require the message data in U32 format.
- Surface formats with SINT require the message data in S32 format.
- All other surface formats require the message data in FLOAT32 format.

The untyped surface categories, both of which use the RAW surface format, perform no type conversion. A raw buffer uses just the U address parameter, which specifies the byte offset into the surface, which must be a multiple of 4. A structured buffer uses the U address parameter as an array index and the V address parameter as a byte offset into the array element (which also must be a multiple of 4).

For both raw and structured buffers, up to 4 DWords are accessed beginning at the byte address determined. These 4 dwords correspond to the red, green, blue, and alpha channels in that order with red mapping to the lowest order DWord. The atomic operation messages only access the first DWord (corresponding to the red channel for typed messages).

The atomic operation messages cause atomic read-modify-write operations on the "destination" location addressed. In the table below, the new value of the destination (new_dst) is computed as indicated based on the old value of the destination (old_dst) and up to two sources included in the message (src0 and src1). Optionally, a value can be returned by the message (ret).

The atomic operations guarantee that the read and the write are performed atomically, meaning that no read or write to the same memory location from this thread or any other thread can occur between the read and the write.



The following atomic operations are available, along with the specific operation performed for each and the return value:

Atomic Operation	new_dst	ret
AOP_AND	$\text{old_dst} \& \text{src0}$	old_dst
AOP_OR	$\text{old_dst} \text{src0}$	old_dst
AOP_XOR	$\text{old_dst} \wedge \text{src0}$	old_dst
AOP_MOV	src0	old_dst
AOP_INC	$\text{old_dst} + 1$	old_dst
AOP_DEC	$\text{old_dst} - 1$	old_dst
AOP_ADD	$\text{old_dst} + \text{src0}$	old_dst
AOP_SUB	$\text{old_dst} - \text{src0}$	old_dst
AOP_REVSUB	$\text{src0} - \text{old_dst}$	old_dst
AOP_IMAX	$\text{imax}(\text{old_dst}, \text{src0})$	old_dst
AOP_IMIN	$\text{imin}(\text{old_dst}, \text{src0})$	old_dst
AOP_UMAX	$\text{umax}(\text{old_dst}, \text{src0})$	old_dst
AOP_UMIN	$\text{umin}(\text{old_dst}, \text{src0})$	old_dst
AOP_CMPWR	$(\text{src0} == \text{old_dst}) ? \text{src1} : \text{old_dst}$	old_dst
AOP_PREDEC	$\text{old_dst} - 1$	new_dst
AOP_CMPWR8B	$(\text{src08B} == \text{old_dst8B}) ? \text{src18B} : \text{old_dst8B}$	old_dst8B

Programming Note: src08B is 8 bytes, src18B is 8 bytes, and old_dst8B is 8 bytes in length.

Programming Note: AOP_CMPWR8B is not supported for SLM.

Programming Note: AOP_CMPWR8B addresses must be QWord-aligned.

Note: imax/imin assume operands are signed integers, umax/umin assume operands are unsigned integers. All other operations treat all values as 32-bit unsigned integers. Add and subtract operations wrap without any special indication.

Restrictions:

For untyped messages, the **Tile Mode** must be LINEAR.

For untyped messages, the **Surface Format** must be RAW and the **Surface Type** must be SURFTYPE_BUFFER or SURFTYPE_STRBUF.

For typed messages, the **Surface Type** must be SURFTYPE_1D, 2D, 3D, or BUFFER.



Surface Format for Typed Surface Reads

Project	Surface Format Name
	R16G16B16A16_UINT
	R8G8B8A8_UINT
	R16G16_UINT
	R32_SINT
	R32_UINT
	R32_FLOAT
	R8G8_UINT
	R16_UINT
	R8_UINT

Surface Format for Typed Surface Reads

Project	Surface Format Name
	R32G32B32A32_FLOAT
	R32G32B32A32_SINT
	R32G32B32A32_UINT
	R16G16B16A16_UNORM
	R16G16B16A16_SNORM
	R16G16B16A16_SINT
	R16G16B16A16_UINT
	R16G16B16A16_FLOAT
	R32G32_FLOAT
	R32G32_SINT
	R32G32_UINT
	B8G8R8A8_UNORM
	R10G10B10A2_UNORM
	R10G10B10A2_UINT
	R8G8B8A8_UNORM
	R8G8B8A8_SNORM
	R8G8B8A8_SINT
	R8G8B8A8_UINT
	R16G16_UNORM
	R16G16_SNORM
	R16G16_SINT
	R16G16_UINT
	R16G16_FLOAT
	B10G10R10A2_UNORM
	R11G11B10_FLOAT



Project	Surface Format Name
	R32_SINT
	R32_UINT
	R32_FLOAT
	B5G6R5_UNORM
	B5G5R5A1_UNORM
	B4G4R4A4_UNORM
	R8G8_UNORM
	R8G8_SNORM
	R8G8_SINT
	R8G8_UINT
	R16_UNORM
	R16_SNORM
	R16_SINT
	R16_UINT
	R16_FLOAT
	B5G5R5X1_UNORM
	R8_UNORM
	R8_SNORM
	R8_SINT
	R8_UINT
	A8_UNORM

General Restrictions

For typed surface writes where the Surface Format has components that are not byte-aligned, each shader channel select in the surface state must be set to a unique surface channel (SCS_RED, SCS_GREEN, SCS_BLUE, SCS_ALPHA) and the value of (SCS_ZERO, SCS_ONE) cannot be selected. Also all channels must be enabled for writing.

The **Surface Format** for typed atomic operations must be R32_UINT or R32_SINT.

For atomic operations, each shader channel select in the surface state must be set to the same surface channel (R = SCS_RED, G = SCS_GREEN, B = SCS_BLUE, A = SCS_ALPHA).

For untyped messages accessing SURFTYPE_STRBUF, the V address (byte offset) must be DWord-aligned (low 2 bits must be zero).

For untyped messages accessing SURFTYPE_BUFFER, the U address (byte offset) must be DWord-aligned (low 2 bits must be zero).

Typed messages only support SIMD8.



Project-Specific Restrictions

Project	Restriction
	The stateless model support is limited to untyped messages. Furthermore, they are treated as SURFTYPE_BUFFER and Surface Format of RAW. The bounds checking for the stateless message is 4GB overflow and < General State upper bound.

Execution Mask

SIMD16: The 16 bits of the execution mask are ANDed with the 16 bits of the **Pixel/Sample Mask** from the message header and the resulting mask is used to determine which slots are read into the destination GRF register (for read), or which slots are written to the surface (for write). If the header is not present, only the execution mask is used.

SIMD8: The low 8 bits of the execution mask are ANDed with 8 bits of the **Pixel/Sample Mask** from the message header. For the typed messages, the **Slot Group** in the message descriptor selects either the low or high 8 bits. For the untyped messages, the low 8 bits are always selected. The resulting mask is used to determine which slots are read into the destination GRF register (for read), or which slots are written to the surface (for write). If the header is not present, only the low 8 bits of the execution mask are used.

SIMD4x2: Each group of 4 bits within the low 8 bits of the execution mask are ORed together to create two bits that are used to determine which slots are read into the destination GRF register.

Out-of-Bounds Accesses: Reads to areas outside of the surface return 0, except for the *Typed Surface Read* message that returns 1 in the alpha channel and 0 in the other channels. Writes to areas outside of the surface are dropped and will not modify memory contents.

Note: The *Typed Surface Read* message returns 0 in all channels for out-of-bounds accesses.

Programming Restriction: Writes to overlapping addresses have undefined write ordering.



SIMD Mode, Surface Category, and Message Type Combinations Supported

SIMD Mode	Surface Category	Message Type	Project
SIMD16	Untyped	Read	
SIMD16	Untyped	Write	
SIMD16	Untyped	Atomic	
SIMD8	Untyped	Read	
SIMD8	Untyped	Write	
SIMD8	Untyped	Atomic	
SIMD8	Typed	Read	
SIMD8	Typed	Write	
SIMD8	Typed	Atomic	
SIMD4x2	Untyped	Read	
SIMD4x2	Untyped	Write	
SIMD4x2	Untyped	Atomic	
SIMD4x2	Typed	Read	
SIMD4x2	Typed	Write	
SIMD4x2	Typed	Atomic	

The following table indicates the hardware interpretation of each input parameter based on surface type. Parameters with blank entries are ignored by hardware if delivered.

Surface Type	"Surface Array" Field in SURFACE_STATE	U Address	V Address	R Address	LOD
SURFTYPE_1D	disabled	X pixel address			LOD
	enabled	X pixel address	array index		LOD
SURFTYPE_2D	disabled	X pixel address	Y pixel address		LOD
	enabled	X pixel address	Y pixel address	array index	LOD
SURFTYPE_3D	disabled	X pixel address	Y pixel address	Z pixel address	LOD
SURFTYPE_BUFFER	disabled	buffer index			
SURFTYPE_STRBUF	disabled	buffer index	byte offset		

Project:	HSW
Note: For 1D surface type SIMD4x2, the array index must be placed in the R address parameter instead of the V address parameter.	



Typed Surface Read/Write Message Descriptor

Bit	Description
13	<p>Slot Group</p> <p>This field controls which 8 bits of Pixel/Sample Mask in the message header are ANDed with the execution mask to determine which slots are accessed. This field is ignored if the header is not present.</p> <p>Format = U1</p> <p>0: Use low 8 slots</p> <p>1: Use high 8 slots</p>
12	Ignored
11	<p>Alpha Channel Mask</p> <p>For the read message, indicates that alpha will be included in the writeback message. For the write message, indicates that alpha is included in the message payload, and that alpha will be written to the surface.</p> <p>0: Alpha channel included</p> <p>1: Alpha channel not included</p> <p>Programming Notes:</p> <p>At least one of the channels must be unmasked (the 4-bit channel mask cannot be 1111b).</p>
10	Blue Channel Mask
9	Green Channel Mask
8	Red Channel Mask



Typed Surface Read/Write Message Descriptor

Bit	Description
13:12	<p>Slot Group</p> <p>This field controls which 8 bits of Pixel/Sample Mask in the message header are ANDed with the execution mask to determine which slots are accessed. This field is ignored if the header is not present.</p> <p>Format = U2</p> <p>00: SIMD4x2</p> <p>01: Use low 8 slots</p> <p>10: Use high 8 slots</p> <p>11: Reserved</p>
11	<p>Alpha Channel Mask</p> <p>For the read message, indicates that alpha will be included in the writeback message. For the write message, indicates that alpha is included in the message payload, and that alpha will be written to the surface.</p> <p>0: Alpha channel included</p> <p>1: Alpha channel not included</p> <p>Programming Notes:</p> <p>At least one of the channels must be unmasked (the 4-bit channel mask cannot be 1111b).</p>
10	Blue Channel Mask
9	Green Channel Mask
8	Red Channel Mask



Untyped Surface ReadWrite Message Descriptor

Bits	Description	Project
13:12	SIMD Mode Format = U2 0: SIMD4x2 (valid for reads & writes) 1: SIMD16 2: SIMD8 3: Reserved	
11	Alpha Channel Mask For the read message, indicates that alpha will be included in the writeback message. For the write message, indicates that alpha is included in the message payload, and that alpha will be written to the surface. 0: Alpha channel included 1: Alpha channel not included Programming Notes: For the <i>Untyped Surface Write</i> message, each channel mask cannot be 0 unless all of the lower mask bits are also zero. This means that the only 4-bit channel mask values allowed are 0000b, 1000b, 1100b, and 1110b. Other messages allow any combination of channel masks. For the <i>Untyped Surface Read</i> message, at least one of the channels must be unmasked (the 4-bit channel mask cannot be 1111b).	
10	Blue Channel Mask	
9	Green Channel Mask	
8	Red Channel Mask	

Typed Atomic Operation Message Descriptor

Bit	Description
13	Return Data Control Specifies whether return data is sent back to the thread. Format = Enable
12	Slot Group This field controls which 8 bits of Pixel/Sample Mask in the message header are ANDed with the execution mask to determine which slots are accessed. Format = U1 0: Use low 8 slots 1: Use high 8 slots
11:8	Atomic Operation Type



Bit	Description
	Specifies the atomic operation to be performed. 0000: Reserved 0001: AOP_AND 0010: AOP_OR 0011: AOP_XOR 0100: AOP_MOV 0101: AOP_INC 0110: AOP_DEC 0111: AOP_ADD 1000: AOP_SUB 1001: AOP_REVSUB 1010: AOP_IMAX 1011: AOP_IMIN 1100: AOP_UMAX 1101: AOP_UMIN 1110: AOP_CMPWR 1111: AOP_PREDEC

Typed Atomic Operation SIMD4x2 Message Descriptor

Bit	Description
13	Return Data Control Specifies whether return data is sent back to the thread. Format = Enable
12	Reserved
11:8	Atomic Operation Type Specifies the atomic operation to be performed. 0000: reserved 0001: AOP_AND 0010: AOP_OR 0011: AOP_XOR 0100: AOP_MOV 0101: AOP_INC



Bit	Description
	0110: AOP_DEC
	0111: AOP_ADD
	1000: AOP_SUB
	1001: AOP_REVSUB
	1010: AOP_IMAX
	1011: AOP_IMIN
	1100: AOP_UMAX
	1101: AOP_UMIN
	1110: AOP_CMPWR
	1111: AOP_PREDEC

Untyped Atomic Operation Message Descriptor

Bit	Description
13	Return Data Control Specifies whether return data is sent back to the thread. Format = Enable
12	SIMD Mode Format = U1 0: SIMD16 1: SIMD8
11:8	Atomic Operation Type Specifies the atomic operation to be performed. 0000: 0000: AOP_CMPWR8B 0001: AOP_AND 0010: AOP_OR 0011: AOP_XOR 0100: AOP_MOV 0101: AOP_INC 0110: AOP_DEC 0111: AOP_ADD 1000: AOP_SUB



Bit	Description
	1001: AOP_REVSUB
	1010: AOP_IMAX
	1011: AOP_IMIN
	1100: AOP_UMAX
	1101: AOP_UMIN
	1110: AOP_CMPWR
	1111: AOP_PREDEC

Untyped Atomic Operation SIMD4x2 Message Descriptor

Bit	Description
13	Return Data Control Specifies whether return data is sent back to the thread. Format = Enable
12	Reserved
11:8	Atomic Operation Type Specifies the atomic operation to be performed. 0000: AOP_CMPWR8B 0001: AOP_AND 0010: AOP_OR 0011: AOP_XOR 0100: AOP_MOV 0101: AOP_INC 0110: AOP_DEC 0111: AOP_ADD 1000: AOP_SUB 1001: AOP_REVSUB 1010: AOP_IMAX 1011: AOP_IMIN 1100: AOP_UMAX 1101: AOP_UMIN 1110: AOP_CMPWR 1111: AOP_PREDEC



Atomic Counter Operation Message Descriptor

Bits	Description
13	Return Data Control Specifies whether return data is sent back to the thread. Format = Enable
12	SIMD Mode Format: U1 0: Reserved 1: SIMD8 (low 8 slots)
11:8	Atomic Operation Type Specifies the atomic operation to perform: 0000: Reserved 0001: AOP_AND 0010: AOP_OR 0011: AOP_XOR 0100: AOP_MOV 0101: AOP_INC 0110: AOP_DEC 0111: AOP_ADD 1000: AOP_SUB 1001: AOP_REVSUB 1010: AOP_IMAX 1011: AOP_IMIN 1100: AOP_UMAX 1101: AOP_UMIN 1110: Reserved 1111: AOP_PREDEC

For Append Counter Operations there is no address payload as the address is provided by the append counter field in the surface state. The write data payloads are the same as untyped atomic. The write backs are the same as untyped atomic.



When accessing a surface with the Append Counter Operation, if the Append Counter enable field of the surface state is not 1, the access is treated as out of bounds, with writes ignored and reads returning 0.

Notes

Project	Note
	Do not use operations with a data operand. Use only INC, DEC, or PREDEC.
	For Atomic Counter OPS other than INC, DEC, or PREDEC, the message header is forbidden and not optional.

Atomic Counter Operation SIMD4x2 Message Descriptor

Bits	Description
13	Return Data Control Specifies whether return data is sent back to the thread. Format = Enable
12	Reserved
11:8	Atomic Operation Type Specifies the atomic operation to be performed. 0000: Reserved 0001: AOP_AND 0010: AOP_OR 0011: AOP_XOR 0100: AOP_MOV 0101: AOP_INC 0110: AOP_DEC 0111: AOP_ADD 1000: AOP_SUB 1001: AOP_REVSUB 1010: AOP_IMAX 1011: AOP_IMIN 1100: AOP_UMAX 1101: AOP_UMIN 1110: Reserved 1111: AOP_PREDEC



For Append Counter Operations there is no address payload as the address is provided by the append counter field in the surface state. The write data payloads are the same as untyped atomic 4x2. The write backs are the same as untyped atomic 4x2.

When accessing a surface with the Append Counter Operation, if the Append Counter enable field of the surface state is not 1, the access is treated as out of bounds, with writes ignored and reads returning 0.

Notes

Project	Note
HSW	Do not use operations with a data operand. Use only INC, DEC, or PREDEC.

Message Header

The message header for the untyped messages only needs to be delivered for pixel shader threads, where the execution mask may indicate pixels/samples that are enabled only due to derivative (LOD) calculations, but the corresponding slot on the surface must not be accessed. Typed messages (which go to the render cache data port) must include the header.

DWord	Bits	Description	Project
M0.7	31:16	Ignored	
	15:0	Pixel/Sample Mask. This field contains the 16-bit pixel/sample mask to be used for SIMD16 and SIMD8 messages. All 16 bits are used for SIMD16 messages. For typed SIMD8 messages, Slot Group selects which 8 bits of this field are used. For untyped SIMD8 messages, the low 8 bits of this field are used. If the header is not delivered, this field defaults to all ones. The field is ignored for SIMD4x2 messages.	
M0.6	31:0	Ignored	
M0.5	31:0	Immediate Buffer Base Address. Specifies the surface base address for messages in which the Binding Table Index is 255 (stateless model), else this field is ignored. This pointer is relative to the General State Base Address . Format = GeneralStateOffset[31:10]	
M0.4	31:0	Ignored (reserved for hardware delivery of binding table pointer)	
M0.3	31:0	Ignored	
M0.2	31:0	Ignored	
M0.1	31:0	Ignored	
M0.0	31:0	Ignored	

Message Payload

The message payload consists of the following:

- For the read messages, only an address payload is delivered.
- For the write messages, an address payload is followed by the write data payload.



- For the atomic operation messages, an address payload is followed by the source payload.
- For SIMD16 and SIMD8 messages, the message length is used to determine how many address parameters are included in the message. The number of message registers in the write data payload is determined by the number of channel mask bits that are enabled, and the number of message registers in the source payload is determined by the atomic operation operation. Thus, one or neither of these two values (depending on the message type), plus one for the header, can be subtracted from the message length to determine the number of message registers in the address payload, from which the number of address parameters can be determined.

SIMD16 Address Payload

The payload of a SIMD16 message provides address parameters to process 16 slots. The possible address parameters are U and V (since SIMD16 is only supported with untyped messages). The number of parameters required depends on the surface type being accessed. Each parameter takes two message registers. Each parameter always takes a consistent position in the input payload. The length field can be used to send a shorter message, but intermediate parameters cannot be skipped as there is no way to signal this.

DWord	Bit	Description
M1.7	31:0	Slot 7 U Address Specifies the U Address for slot 7. Format = U32
M1.6	31:0	Slot 6 U Address
M1.5	31:0	Slot 5 U Address
M1.4	31:0	Slot 4 U Address
M1.3	31:0	Slot 3 U Address
M1.2	31:0	Slot 2 U Address
M1.1	31:0	Slot 1 U Address
M1.0	31:0	Slot 0 U Address
M2.7	31:0	Slot 15 U Address
M2.6	31:0	Slot 14 U Address
M2.5	31:0	Slot 13 U Address
M2.4	31:0	Slot 12 U Address
M2.3	31:0	Slot 11 U Address
M2.2	31:0	Slot 10 U Address
M2.1	31:0	Slot 9 U Address
M2.0	31:0	Slot 8 U Address
M3		Slots 7:0 V Address
M4		Slots 15:8 V Address



SIMD16 Source Payload (Atomic Operation Message Only)

The source payload follows the address payload for atomic operation messages. Depending on the atomic operation, zero, one, or two sources are required. If the source is not required, it must not be included. Message registers given here could be a lower number if some of the address parameters are not included.

The following atomic operations require no sources, thus the source payload is not delivered: AOP_INC, AOP_DEC, AOP_PREDEC

The following atomic operations require both Source0 and Source1: AOP_CMPWR

All of the remaining atomic operations require Source0 only.

DWord	Bit	Description
M5.7	31:0	Slot 7 Source0 Specifies Source0 for slot 7. Format = S31 for AOP_IMAX and AOP_IMIN, U32 for all other operations
M5.6	31:0	Slot 6 Source0
M5.5	31:0	Slot 5 Source0
M5.4	31:0	Slot 4 Source0
M5.3	31:0	Slot 3 Source0
M5.2	31:0	Slot 2 Source0
M5.1	31:0	Slot 1 Source0
M5.0	31:0	Slot 0 Source0
M6.7	31:0	Slot 15 Source0
M6.6	31:0	Slot 14 Source0
M6.5	31:0	Slot 13 Source0
M6.4	31:0	Slot 12 Source0
M6.3	31:0	Slot 11 Source0
M6.2	31:0	Slot 10 Source0
M6.1	31:0	Slot 9 Source0
M6.0	31:0	Slot 8 Source0
M7		Slots 7:0 Source1
M8		Slots 15:8 Source1



SIMD16 Source Payload (AOP_CMPWR8B Only)

DWord	Bit	Description
M5.7	31:0	Slot 7 Source0[31:0] Specifies Source0[31:0] for slot 7. Format = U32
M5.6	31:0	Slot 6 Source0[31:0]
M5.5	31:0	Slot 5 Source0[31:0]
M5.4	31:0	Slot 4 Source0[31:0]
M5.3	31:0	Slot 3 Source0[31:0]
M5.2	31:0	Slot 2 Source0[31:0]
M5.1	31:0	Slot 1 Source0[31:0]
M5.0	31:0	Slot 0 Source0[31:0]
M6.7	31:0	Slot 15 Source0[31:0]
M6.6	31:0	Slot 14 Source0[31:0]
M6.5	31:0	Slot 13 Source0[31:0]
M6.4	31:0	Slot 12 Source0[31:0]
M6.3	31:0	Slot 11 Source0[31:0]
M6.2	31:0	Slot 10 Source0[31:0]
M6.1	31:0	Slot 9 Source0[31:0]
M6.0	31:0	Slot 8 Source0[31:0]
M7		Slots 7:0 Source0[63:32]
M8		Slots 15:8 Source0[63:32]
M9		Slots 7:0 Source1[31:0]
M10		Slots 15:8 Source1[31:0]
M11		Slots 7:0 Source1[63:32]
M12		Slots 15:8 Source1[63:32]



SIMD16 Write Data Payload (Write Message Only)

The write data payload follows the address payload for write messages. Actual position within the message may vary if some of the parameters are not included or if some of the channel mask bits are asserted. Any parameter or write channel not included in the payload is skipped, with message phases below it being renumbered to take up the vacated space.

DWord	Bit	Description
M5.7	31:0	Slot 7 Red Specifies the value of the red channel to be written for slot 7. Format = 32 bits raw data.
M5.6	31:0	Slot 6 Red
M5.5	31:0	Slot 5 Red
M5.4	31:0	Slot 4 Red
M5.3	31:0	Slot 3 Red
M5.2	31:0	Slot 2 Red
M5.1	31:0	Slot 1 Red
M5.0	31:0	Slot 0 Red
M6.7	31:0	Slot 15 Red
M6.6	31:0	Slot 14 Red
M6.5	31:0	Slot 13 Red
M6.4	31:0	Slot 12 Red
M6.3	31:0	Slot 11 Red
M6.2	31:0	Slot 10 Red
M6.1	31:0	Slot 9 Red
M6.0	31:0	Slot 8 Red
M7		Slots 7:0 Green
M8		Slots 15:8 Green
M9		Slots 7:0 Blue
M10		Slots 15:8 Blue
M11		Slots 7:0 Alpha
M12		Slots 15:8 Alpha

SIMD8 Address Payload

The payload of a SIMD8 message provides address parameters to process 8 slots. The possible address parameters are U, V, R, and LOD. The number of parameters required depends on the surface type being accessed. Each parameter takes one message register. Each parameter always takes a consistent position in the input payload. The length field can be used to send a shorter message, but intermediate parameters cannot be skipped as there is no way to signal this.



Programming Notes:

For untyped messages of surface type SURFTYPE_BUFFER, either U only can be sent or U and V can be sent. If V is sent it is ignored

For untyped messages of surface type SURFTYPE_STRBUF, both U and V must be sent.

DWord	Bits	Description
M1.7	31:0	Slot 7 U Address Specifies the U Address for slot 7. Format = U32
M1.6	31:0	Slot 6 U Address
M1.5	31:0	Slot 5 U Address
M1.4	31:0	Slot 4 U Address
M1.3	31:0	Slot 3 U Address
M1.2	31:0	Slot 2 U Address
M1.1	31:0	Slot 1 U Address
M1.0	31:0	Slot 0 U Address
M2		Slots 7:0 V Address
M3		Slots 7:0 R Address Programming Notes: This register can only be delivered for the <i>Typed</i> message types.
M4		Slots 7:0 LOD Programming Notes: This register can only be delivered for the <i>Typed</i> message types.

SIMD8 Source Payload (Atomic Operation Message Only)

The source payload follows the address payload for atomic operation messages. Depending on the atomic operation, zero, one, or two sources are required. If the source is not required, it must not be included. Message registers given here could be a lower number if some of the address parameters are not included.

The following atomic operations require no sources, thus the source payload is not delivered: AOP_INC, AOP_DEC, AOP_PREDEC

The following atomic operations require both Source0 and Source1: AOP_CMPWR

All of the remaining atomic operations require Source0 only.



DWord	Bit	Description
M5.7	31:0	Slot 7 Source0 Specifies Source0 for slot 7. Format = S31 for AOP_IMAX and AOP_IMIN, U32 for all other operations
M5.6	31:0	Slot 6 Source0
M5.5	31:0	Slot 5 Source0
M5.4	31:0	Slot 4 Source0
M5.3	31:0	Slot 3 Source0
M5.2	31:0	Slot 2 Source0
M5.1	31:0	Slot 1 Source0
M5.0	31:0	Slot 0 Source0
M6		Slots 7:0 Source1

SIMD8 Write Data Payload (Write Message Only)

The write data payload follows the address payload for write messages. Actual position within the message may vary if some of the parameters are not included or if some of the channel mask bits are asserted. Any parameter or write channel not included in the payload is skipped, with message phases below it being renumbered to take up the vacated space.

DWord	Bit	Description
M5.7	31:0	Slot 7 Red Specifies the value of the red channel to be written for slot 7. For <i>Untyped</i> messages: Format = 32 bits raw data. For <i>Typed</i> messages: Format = IEEE Float, S31, or U32 depending on the Surface Format of the surface being accessed. SINT formats use S31, UINT formats use U32, and all other formats use Float.
M5.6	31:0	Slot 6 Red
M5.5	31:0	Slot 5 Red
M5.4	31:0	Slot 4 Red
M5.3	31:0	Slot 3 Red
M5.2	31:0	Slot 2 Red
M5.1	31:0	Slot 1 Red
M5.0	31:0	Slot 0 Red
M6		Slots 7:0 Green
M7		Slots 7:0 Blue
M8		Slots 7:0 Alpha



SIMD8 Write Data Payload (Tile W Write Message Only)

The write data payload follows the address payload for write messages. Actual position within the message may vary if some of the parameters are not included.

DWord	Bit	Description
M5.7	31:8	Ignored
	7:0	Slot 7 Red Specifies the value of the red channel to be written for slot 7. For <i>Typed</i> messages: Format = U8
M5.6	31:8	Ignored
	7:0	Slot 6 Red
M5.5	31:8	Ignored
	7:0	Slot 5 Red
M5.4	31:8	Ignored
	7:0	Slot 4 Red
M5.3	31:8	Ignored
	7:0	Slot 3 Red
M5.2	31:8	Ignored
	7:0	Slot 2 Red
M5.1	31:8	Ignored
	7:0	Slot 1 Red
M5.0	31:8	Ignored
	7:0	Slot 0 Red

SIMD4x2 Address Payload

The payload of a SIMD4x2 message provides address parameters to process 2 slots.

DWord	Bits	Description	Project
M1.7	31:0	Slot 1 LOD Programming Note: This register can only be delivered for the <i>Typed</i> message types.	HSW
M1.6	31:0	Slot 1 R Address Programming Note: This register can only be delivered for the <i>Typed</i> message types.	
M1.5	31:0	Slot 1 V Address	



DWord	Bits	Description	Project
		Format = U32	
M1.4	31:0	Slot 1 U Address Format = U32	
M1.3	31:0	Slot 0 LOD	
M1.2	31:0	Slot 0 R Address	
M1.1	31:0	Slot 0 V Address	
M1.0	31:0	Slot 0 U Address	

SIMD4x2 Source Payload (Atomic Operation Message Only)

The source payload follows the address payload for atomic operation messages. Depending on the atomic operation, zero, one, or two sources are required. If the source is not required, it must not be included. Message registers given here could be a lower number if some of the address parameters are not included.

The following atomic operations require no sources, thus the source payload is not delivered: AOP_INC, AOP_DEC, AOP_PREDEC

The following atomic operations require both Source0 and Source1: AOP_CMPWR

All of the remaining atomic operations require Source0 only.

DWord	Bit	Description
M2.7	31:0	Ignored
M2.6	31:0	Ignored
M2.5	31:0	Slot 1 Source1 Specifies Source1 for slot 1. Format = S31 for AOP_IMAX and AOP_IMIN, U32 for all other operations
M2.4	31:0	Slot 1 Source0
M2.3	31:0	Ignored
M2.2	31:0	Ignored
M2.1	31:0	Slot 0 Source1
M2.0	31:0	Slot 0 Source0

SIMD4x2 Source Payload (AOP_CMPWR8B Only)

DWord	Bit	Description
M2.7	31:0	Slot 1 Source1 [63:32]
M2.6	31:0	Slot 1 Source1 [31:0]
M2.5	31:0	Slot 1 Source0 [63:32]
M2.4	31:0	Slot 1 Source0 [31:0]



DWord	Bit	Description
M2.3	31:0	Slot 0 Source1 [63:32]
M2.2	31:0	Slot 0 Source1 [31:0]
M2.1	31:0	Slot 0 Source0 [63:32]
M2.0	31:0	Slot 0 Source0 [31:0]

SIMD4x2 Write Data Payload (Write Message Only)

The write data payload follows the address payload for write messages.

DWord	Bit	Description
M2.7	31:0	Slot 1 Alpha Specifies the value of the red channel to be written for slot 7. For <i>Untyped</i> messages: Format = 32 bits raw data. For <i>Typed</i> messages: Format = IEEE Float, S31, or U32 depending on the Surface Format of the surface being accessed. SINT formats use S31, UINT formats use U32, and all other formats use Float.
M2.6	31:0	Slot 1 Blue
M2.5	31:0	Slot 1 Green
M2.4	31:0	Slot 1 Red
M2.3	31:0	Slot 0 Alpha
M2.2	31:0	Slot 0 Blue
M2.1	31:0	Slot 0 Green
M2.0	31:0	Slot 0 Red



Writeback Message

SIMD8 DWORD Read

DWord	Bit	Description
W0.7	31:0	DWord[Offset7]
W0.6	31:0	DWord[Offset6]
W0.5	31:0	DWord[Offset5]
W0.4	31:0	DWord[Offset4]
W0.3	31:0	DWord[Offset3]
W0.2	31:0	DWord[Offset2]
W0.1	31:0	DWord[Offset1]
W0.0	31:0	DWord[Offset0]



SIMD8 QWORD Read

DWord	Bit	Description
W0.7 W0.6	63:0	QWord[Offset3]
W0.5 W0.4	63:0	QWord[Offset2]
W0.3 W0.2	63:0	QWord[Offset1]
W0.1 W0.0	63:0	QWord[Offset0]
W1.7 W1.6	63:0	QWord[Offset7]
W1.5 W1.4	63:0	QWord[Offset6]
W1.3 W1.2	63:0	QWord[Offset5]
W1.1 W1.0	63:0	QWord[Offset4]



SIMD16 Read

A SIMD16 writeback message consists of up to 8 destination registers. Which registers are returned is determined by the channel mask in the message descriptor. Each asserted channel mask results in the destination register of the corresponding channel being skipped in the writeback message, and all channels with higher numbered registers being dropped down to fill in the space occupied by the masked channel. For example, if only red and alpha are enabled, red is sent to regid+0 and regid+1, and alpha to regid+2 and regid+3. The slots written within each destination register is determined by the execution mask on the "send" instruction.

DWord	Bit	Description
W0.7	31:0	Slot 7 Red: Specifies the value of the red channel for slot 7. Format = 32 bits raw data.
W0.6	31:0	Slot 6 Red
W0.5	31:0	Slot 5 Red
W0.4	31:0	Slot 4 Red
W0.3	31:0	Slot 3 Red
W0.2	31:0	Slot 2 Red
W0.1	31:0	Slot 1 Red
W0.0	31:0	Slot 0 Red
W1.7	31:0	Slot 15 Red
W1.6	31:0	Slot 14 Red
W1.5	31:0	Slot 13 Red
W1.4	31:0	Slot 12 Red
W1.3	31:0	Slot 11 Red
W1.2	31:0	Slot 10 Red
W1.1	31:0	Slot 9 Red
W1.0	31:0	Slot 8 Red
W2		Slots 7:0 Green
W3		Slots 15:8 Green
W4		Slots 7:0 Blue
W5		Slots 15:8 Blue
W6		Slots 7:0 Alpha
W7		Slots 15:8 Alpha



SIMD8 Read

A SIMD8 writeback message consists of up to 4 destination registers. Which registers are returned is determined by the channel mask in the message descriptor. Each asserted channel mask results in the destination register of the corresponding channel being skipped in the writeback message, and all channels with higher numbered registers being dropped down to fill in the space occupied by the masked channel. For example, if only red and alpha are enabled, red is sent to regid+0, and alpha to regid+1. The slots written within each destination register is determined by the execution mask on the "send" instruction.

DWord	Bit	Description
W0.7	31:0	Slot 7 Red: Specifies the value of the red channel for slot 7. For <i>Untyped</i> messages: Format = 32 bits raw data. For <i>Typed</i> messages: Format = IEEE Float, S31, or U32 depending on the Surface Format of the surface being accessed. SINT formats use S31, UINT formats use U32, and all other formats use Float.
W0.6	31:0	Slot 6 Red
W0.5	31:0	Slot 5 Red
W0.4	31:0	Slot 4 Red
W0.3	31:0	Slot 3 Red
W0.2	31:0	Slot 2 Red
W0.1	31:0	Slot 1 Red
W0.0	31:0	Slot 0 Red
W1		Slots 7:0 Green
W2		Slots 7:0 Blue
W3		Slots 7:0 Alpha



SIMD8 Read (Tile W)

The slots written within each destination register is determined by the execution mask on the "send" instruction.

DWord	Bit	Description
M5.7	31:8	Reserved (0)
	7:0	Slot 7 Red Specifies the value of the red channel to be written for slot 7. For <i>Typed</i> messages: Format = U8
M5.6	31:8	Reserved (0)
	7:0	Slot 6 Red
M5.5	31:8	Reserved (0)
	7:0	Slot 5 Red
M5.4	31:8	Reserved (0)
	7:0	Slot 4 Red
M5.3	31:8	Reserved (0)
	7:0	Slot 3 Red
M5.2	31:8	Reserved (0)
	7:0	Slot 2 Red
M5.1	31:8	Reserved (0)
	7:0	Slot 1 Red
M5.0	31:8	Reserved (0)
	7:0	Slot 0 Red



SIMD4x2 Read

A SIMD4x2 writeback message always consists of a single message register containing all four color channels of each of the two slots. The channel mask bits as well as the execution mask on the "send" instruction are used to determine which of the channels in the destination register are overwritten. If any of the four execution mask bits for a slot is asserted, that slot is considered to be active. The active channels in the channel mask will be written in the destination register for that slot. If the slot is inactive (all four execution mask bits deasserted), none of the channels for that slot will be written in the destination register.

DWord	Bit	Description
W0.7	31:0	Slot 1 Alpha: Specifies the value of the pixel's alpha channel. Format = 32 bits raw data.
W0.6	31:0	Slot 1 Blue
W0.5	31:0	Slot 1 Green
W0.4	31:0	Slot 1 Red
W0.3	31:0	Slot 0 Alpha
W0.2	31:0	Slot 0 Blue
W0.1	31:0	Slot 0 Green
W0.0	31:0	Slot 0 Red



SIMD16 Atomic Operation

A writeback message is only returned for an Atomic Operation message if the **Send Return Data** field in the message descriptor is enabled. The execution mask on the "send" instruction indicates which channels in the destination registers are overwritten.

DWord	Bit	Description
W0.7	31:0	Slot 7 Return Data: Specifies the value of the return data for slot 7. Format = U32
W0.6	31:0	Slot 6 Return Data
W0.5	31:0	Slot 5 Return Data
W0.4	31:0	Slot 4 Return Data
W0.3	31:0	Slot 3 Return Data
W0.2	31:0	Slot 2 Return Data
W0.1	31:0	Slot 1 Return Data
W0.0	31:0	Slot 0 Return Data
W1.7	31:0	Slot 15 Return Data
W1.6	31:0	Slot 14 Return Data
W1.5	31:0	Slot 13 Return Data
W1.4	31:0	Slot 12 Return Data
W1.3	31:0	Slot 11 Return Data
W1.2	31:0	Slot 10 Return Data
W1.1	31:0	Slot 9 Return Data
W1.0	31:0	Slot 8 Return Data



SIMD16 Atomic Operation (AOP_CMPWR8B Only)

A writeback message is only returned for an Atomic Operation AOP_CMPWR8B message if the **Send Return Data** field in the message descriptor is enabled. The execution mask on the "send" instruction indicates which channels in the destination registers are overwritten.

DWord	Bit	Description
W0.7	31:0	Slot 7 Return Data[31:0] : Specifies the value of the return data for slot 7. Format = U32
W0.6	31:0	Slot 6 Return Data[31:0]
W0.5	31:0	Slot 5 Return Data[31:0]
W0.4	31:0	Slot 4 Return Data[31:0]
W0.3	31:0	Slot 3 Return Data[31:0]
W0.2	31:0	Slot 2 Return Data[31:0]
W0.1	31:0	Slot 1 Return Data[31:0]
W0.0	31:0	Slot 0 Return Data[31:0]
W1.7	31:0	Slot 15 Return Data[31:0]
W1.6	31:0	Slot 14 Return Data[31:0]
W1.5	31:0	Slot 13 Return Data[31:0]
W1.4	31:0	Slot 12 Return Data[31:0]
W1.3	31:0	Slot 11 Return Data[31:0]
W1.2	31:0	Slot 10 Return Data[31:0]
W1.1	31:0	Slot 9 Return Data[31:0]
W1.0	31:0	Slot 8 Return Data[31:0]
W2		Slot 7:0 Return Data[63:32]
W3		Slot 15:8 Return Data[63:32]



SIMD8 Atomic Operation

A writeback message is only returned for an Atomic Operation message if the **Send Return Data** field in the message descriptor is enabled. The execution mask on the "send" instruction indicates which channels in the destination registers are overwritten.

DWord	Bit	Description
W0.7	31:0	Slot 7 Return Data: Specifies the value of the return data for slot 7. Format = U32
W0.6	31:0	Slot 6 Return Data
W0.5	31:0	Slot 5 Return Data
W0.4	31:0	Slot 4 Return Data
W0.3	31:0	Slot 3 Return Data
W0.2	31:0	Slot 2 Return Data
W0.1	31:0	Slot 1 Return Data
W0.0	31:0	Slot 0 Return Data



SIMD8 Atomic Operation (AOP_CMPWR8B Only)

A writeback message is only returned for an Atomic Operation AOP_CMPWR8B message if the **Send Return Data** field in the message descriptor is enabled. The execution mask on the "send" instruction indicates which channels in the destination registers are overwritten.

DWord	Bit	Description
W0.7	31:0	Slot 7 Return Data[31:0] : Specifies the value of the return data for slot 7. Format = U32
W0.6	31:0	Slot 6 Return Data[31:0]
W0.5	31:0	Slot 5 Return Data[31:0]
W0.4	31:0	Slot 4 Return Data[31:0]
W0.3	31:0	Slot 3 Return Data[31:0]
W0.2	31:0	Slot 2 Return Data[31:0]
W0.1	31:0	Slot 1 Return Data[31:0]
W0.0	31:0	Slot 0 Return Data[31:0]
W1.7	31:0	Slot 7 Return Data[63:32]
W1.6	31:0	Slot 6 Return Data[63:32]
W1.5	31:0	Slot 5 Return Data[63:32]
W1.4	31:0	Slot 4 Return Data[63:32]
W1.3	31:0	Slot 3 Return Data[63:32]
W1.2	31:0	Slot 2 Return Data[63:32]
W1.1	31:0	Slot 1 Return Data[63:32]
W1.0	31:0	Slot 0 Return Data[63:32]



SIMD4x2 Atomic Operation

A writeback message is only returned for an Atomic Operation message if the **Send Return Data** field in the message descriptor is enabled. The execution mask on the "send" instruction indicates which channels in the destination registers are overwritten.

DWord	Bit	Description
W0.7	31:0	reserved – not written to GRF
W0.6	31:0	reserved – not written to GRF
W0.5	31:0	reserved – not written to GRF
W0.4	31:0	Slot 1 Return Data: Specifies the value of the return data for slot 1. Format = U32
W0.3	31:0	reserved – not written to GRF
W0.2	31:0	reserved – not written to GRF
W0.1	31:0	reserved – not written to GRF
W0.0	31:0	Slot 0 Return Data



SIMD4x2 Atomic Operation (AOP_CMPWR8B Only)

A writeback message is only returned for an Atomic Operation AOP_CMPWR8B message if the **Send Return Data** field in the message descriptor is enabled. The execution mask on the "send" instruction indicates which channels in the destination registers are overwritten.

DWord	Bit	Description
W0.7	31:0	reserved – not written to GRF
W0.6	31:0	reserved – not written to GRF
W0.5	31:0	Slot 1 Return Data: [63:32]
W0.4	31:0	Slot 1 Return Data: [31:0]
W0.3	31:0	reserved – not written to GRF
W0.2	31:0	reserved – not written to GRF
W0.1	31:0	Slot 0 Return Data: [63:32]
W0.0	31:0	Slot 0 Return Data[31:0]

Message Descriptor

Bit	Description
13	<p>Invalidate After Read Enable [DevIVB+] only</p> <p>This field, if enabled, causes all lines in the L3 cache accessed by the message to be invalidated after the read occurs, regardless of whether the line contains modified data. It is intended as a performance hint indicating that the data will no longer be used to avoid writing back data to memory. This field is ignored for write messages.</p> <p>Enabling this field is intended for scratch and spill/fill, where the memory is used only by a single thread and thus does not need to be maintained after the thread completes.</p> <p>Format = Enable</p>
12:11	<p>Message sub-type:</p> <p>00: OWord Block Read/Write 01: Unaligned OWord Block Read 10: OWord Dual Block Read/Write 11: HWord Block Read/Write</p>
10:8	<p>Block Size. Specifies the number of elements transferred see table below</p>



	00	01	10	11
Block Size	Oword	UnAligned Oword	Oword Dual	Hword
000	1 OWord, read into or written from the low 128 bits of the destination register	1 OWord, read into or written from the low 128 bits of the destination register	reserved	reserved
001	1 OWord, read into or written from the high 128 bits of the destination register	1 OWord, read into or written from the high 128 bits of the destination register	1 Oword	1 HWord
010	2 OWords	2 OWords	reserved	2 HWord
011	4 OWords	4 OWords	4 OWords	4 HWord
100	8 OWords	8 OWords	reserved	8 HWord
101	reserved	reserved	reserved	reserved
110	reserved	reserved	reserved	reserved
111	reserved	reserved	reserved	reserved

Untyped Atomic Float Add Operation Message Descriptor

Bit	Description
13	Return Data Control Specifies whether return data is sent back to the thread. Format = Enable
12	SIMD Mode Format = U1 0: SIMD16 1: SIMD8
11	Data Size This field controls the data size of the operation Format = U1 0: DWORD size 1: QWORD
10:8	Reserved



Message Header

The message header for the untyped messages only needs to be delivered for pixel shader threads, where the execution mask may indicate pixels/samples that are enabled only due to derivative (LOD) calculations, but the corresponding slot on the surface must not be accessed.

DWord	Bit	Description
M0.7	31:16	Ignored
	15:0	Pixel/Sample Mask. This field contains the 16-bit pixel/sample mask to be used for SIMD16 and SIMD8 messages. All 16 bits are used for SIMD16 messages. For untyped SIMD8 messages, the low 8 bits of this field are used. If the header is not delivered, this field defaults to all ones. The field is ignored for SIMD4x2 messages.
M0.6	31:0	Ignored
M0.5	31:0	Immediate Buffer Base Address. Specifies the surface base address for messages in which the Binding Table Index is 255 (stateless model), otherwise this field is ignored. This pointer is relative to the General State Base Address . Format = GeneralStateOffset[31:10]
M0.4	31:0	Ignored (reserved for hardware delivery of binding table pointer)
M0.3	31:0	Ignored
M0.2	31:0	Ignored
M0.1	31:0	Ignored
M0.0	31:0	Ignored



Message Payload

SIMD16 Address Payload

The payload of a SIMD16 message provides address parameters to process 16 slots. The possible address parameters are U and V (since SIMD16 is only supported with untyped messages). The number of parameters required depends on the surface type being accessed. Each parameter takes two message registers. Each parameter always takes a consistent position in the input payload. The length field can be used to send a shorter message, but intermediate parameters cannot be skipped as there is no way to signal this.

DWord	Bit	Description
M1.7	31:0	Slot 7 U Address Specifies the U Address for slot 7. Format = U32
M1.6	31:0	Slot 6 U Address
M1.5	31:0	Slot 5 U Address
M1.4	31:0	Slot 4 U Address
M1.3	31:0	Slot 3 U Address
M1.2	31:0	Slot 2 U Address
M1.1	31:0	Slot 1 U Address
M1.0	31:0	Slot 0 U Address
M2.7	31:0	Slot 15 U Address
M2.6	31:0	Slot 14 U Address
M2.5	31:0	Slot 13 U Address
M2.4	31:0	Slot 12 U Address
M2.3	31:0	Slot 11 U Address
M2.2	31:0	Slot 10 U Address
M2.1	31:0	Slot 9 U Address
M2.0	31:0	Slot 8 U Address
M3		Slots 7:0 V Address
M4		Slots 15:8 V Address



SIMD8 Address Payload

The payload of a SIMD8 message provides address parameters to process 8 slots. The possible address parameters are U, V. The number of parameters required depends on the surface type being accessed. Each parameter takes one message register. Each parameter always takes a consistent position in the input payload. The length field can be used to send a shorter message, but intermediate parameters cannot be skipped as there is no way to signal this.

DWord	Bit	Description
M1.7	31:0	Slot 7 U Address Specifies the U Address for slot 7. Format = U32
M1.6	31:0	Slot 6 U Address
M1.5	31:0	Slot 5 U Address
M1.4	31:0	Slot 4 U Address
M1.3	31:0	Slot 3 U Address
M1.2	31:0	Slot 2 U Address
M1.1	31:0	Slot 1 U Address
M1.0	31:0	Slot 0 U Address
M2		Slots 7:0 V Address



SIMD16/SIMD8 DWORD Source Payload

Either one or two additional registers (depending on the SIMD mode) of payload contain the sources to be used.

DWord	Bit	Description
M3.7	31:0	DWord[slot7]
M3.6	31:0	DWord[slot6]
M3.5	31:0	DWord[slot5]
M3.4	31:0	DWord[slot4]
M3.3	31:0	DWord[slot3]
M3.2	31:0	DWord[slot2]
M3.1	31:0	DWord[slot1]
M3.0	31:0	DWord[slot0]
M4.7	31:0	DWord[slot15] . This message register is included only for SIMD16
M4.6	31:0	DWord[slot14]
M4.5	31:0	DWord[slot13]
M4.4	31:0	DWord[slot12]
M4.3	31:0	DWord[slot11]
M4.2	31:0	DWord[slot10]
M4.1	31:0	DWord[slot9]
M4.0	31:0	DWord[slot8]



SIMD16/SIMD8 QWORD Source Payload

Either two or four additional registers (depending on the SIMD mode) of payload contain the sources to use.

DWord	Bits	Description
M3.7 M3.6	63:0	QWord[slot3]
M3.5 M3.4	63:0	QWord[slot2]
M3.3 M3.2	63:0	QWord[slot1]
M3.1 M3.0	63:0	QWord[slot0]
M4.7 M4.6	63:0	QWord[slot7]
M4.5 M4.4	63:0	QWord[slot6]
M4.3 M4.2	63:0	QWord[slot5]
M4.1 M4.0	63:0	QWord[slot4]
M5		Qword[slot11:slot8] . This register is only included for SIMD16.
M6		Qword[slot15:slot12] . This register is only included for SIMD16.



Scratch Block Read or Write

This message performs a read or write operation of between 1 and 4 SIMD8 registers to an HWord aligned offset to scratch memory. The HWord offset into the scratch memory is provided in the message descriptor, allowing a single instruction read|write block operation in a single source instruction. 12 bits are provided for the HWord offset, allowing addressing of 4K Hword locations (128KB).

Two modes of channel-enable interpretation are provided: DWord, which support a SIMD8 or SIMD16 DWord channel-serial view of a register, and OWord, which supports a SIMD4x2 view of a register. For operations using SIMD32 processing, two messages should be used, with one of them indicating 'H2' to select the upper 16b of the execution mask.

This message type can only be used with stateless model memory access. Thus binding table entry 0xFF is hard-coded into the execution of this message.

Applications: Scratch space reads/writes for register spill/fill operations.

Execution Mask. The low 8 bits of the execution mask are used to enable the 8 channels in the first and third GRF registers returned (W0, W2) for read, or the first and third write registers sent (M1, M3). The high 8 bits are used similarly for the second and fourth registers (W1, W3 or M2, M4).

For DWord mode, the execution mask delivered with the message dictates DWord-based control of read or write operations. For OWord mode, any one or more asserted bits within the OWord's corresponding execution mask nibble causes read or write operations to occur across all four DWords of the OWord regardless of the setting of any particular DWord's bit.

Out-of-Bounds Accesses. Reads to areas outside of the surface return 0. Writes to areas outside of the surface are dropped and do not modify memory contents.



Message Descriptor

Project	Bits	Description
	17	Operation Type: 0 = Read, 1 = Write
	16	Channel Mode: 0: OWord – Channel enables in effect at the time of 'send' are interpreted such that, if one or more are enabled, the read or write operation occurs on all four DWords. 1: DWord – Channel enables in effect at the time of the 'send' are used as DWord enables, causing the read or write operation to occur only on the DWords whose corresponding channel enable is set.
	15	Invalidate After Read. Indicates whether the cache line should be invalidated after the read: 0: No Invalidate. 1: Invalidate cache line.
	14	Reserved: MBZ
	13:12	Block Size. Indicates the number of SIMD8 registers to be read or written: 00: 1 register 01: 2 registers 10: Reserved 11: 4 registers
	11:0	Offset. A 12-bit HWord offset into the memory Immediate Memory buffer as specified by binding table 0xFF.



Message Header

DWord	Bits	Description
M0.7	31:16	Ignored
	15:0	Ignored
M0.6	31:0	Ignored
M0.5	31:0	Immediate Buffer Base Address. Specifies the surface base address for messages in which the Binding Table Index is 255 (stateless model); otherwise this field is ignored. This pointer is relative to the General State Base Address . Format = GeneralStateOffset[31:10]
M0.4	31:0	Ignored
M0.3	31:0	Ignored
M0.2	31:0	Ignored
M0.1	31:0	Ignored
M0.0	31:0	Ignored

Message Payload (Write)

The table below illustrates the write payload for a message of block size = 4.

DWord	Bits	Description
M1.7:0	255:0	HWord[Offset]
M2.7:0	255:0	HWord[Offset+1]
M3.7:0	255:0	HWord[Offset+2]
M3.7:0	255:0	HWord[Offset+3]

Message Payload (Read)

Read only requires a message header and has no message address payload.

Writeback Message (Read)

The table below illustrates an example where 4 HWords are read through a scratch block read.

DWord	Bits	Description
W0.7:0	255:0	HWord[Offset]
W1.7:0	255:0	HWord[Offset+1]
W2.7:0	255:0	HWord[Offset+2]
W3.7:0	255:0	HWord[Offset+3]



Memory Fence

A memory fence message issued by a thread causes further messages issued by the thread to be blocked until all previous messages issued by the thread to that data port (data cache or render cache) have been globally observed from the point of view of other threads in the system. This includes both read and write messages.

Data is called globally observable by other threads in the system when the data values written to the memory or data cache will now be returned by other threads' read messages when using that same data port. To read globally observable data that was written to a different data port, the thread issuing the data port read message needs to flush its cache (using a memory fence or pipe control) after the program knows that the writing thread issued the memory fence that ensured the global observability.

The memory fence message has an optional commit writeback message. The commit is sent only after all previous messages by this thread to that data port have been globally observed. This writeback can be used by threads to ensure that a fence is honored across both data ports, as each data port's memory fence only honors the corresponding data port messages.

Project	Notes
	The memory fence operation is not required to guarantee SLM memory access ordering between multiple threads in a thread group for the sequence of a write message, a barrier message, and then a read message. (This optimization is due to implementation details of the organization of threads in a thread group, SLM memory, data port messages, and gateway barrier messages.) Beware that the memory fence is still required for non-SLM memory ordering and observability.
	The untyped UAV and typed UAV support are both provided by the data cache. For a thread to ensure both untyped and typed UAV are visible, the thread issues a memory fence message to the data cache data port, and the Commit Enable is no longer required. The data cache ensures that all accesses from that thread prior to the fence are visible, before any access from that thread issued after the fence will become visible. The Commit Enable is only needed if SW needs to ensure any access outside of the data cache and accesses that use the data cache are both visible before continuing. There is no known use case for this at the present time. If such a use case is needed, the thread would then insert an instruction that sources the destination registers from both memory fences before any further data port messages are sent.



Message Descriptor

Project	Bits	Description
	13	Commit Enable Specifies whether the commit is returned to the thread after the fence has been honored. Format = Enable
	12:8	Reserved: MBZ
	12	L3_Flush_RW_Data If enabled causes the L3 to flush any RW data. If disabled RW data is not flushed.
	11	L3_Flush_Constant_Data If enabled causes the L3 to flush any Constant data. If disabled Constant data is not flushed.
	10	L3_Flush_Texture_Data If enabled causes the L3 to flush any Texture data. If disabled Texture data is not flushed.
	9	L3_Flush_Instructions If enabled causes the L3 to flush any Instructions. If disabled Instructions are not flushed.
	8	Reserved: MBZ

Message Header

The fence messages consist of a single phase, and is completely ignored. The message length is always one.

DWord	Bits	Description
M0.7:0	31:0	Ignored

Writeback Message

The writeback message is only sent if **Commit Enable** in the message descriptor is set. The destination register is not modified. Memory fence messages without **Commit Enable** set do not return anything to the thread (response length is 0 and destination register is null).

DWord	Bits	Description
W0.7:0		Reserved



Pixel Data Port

Cache Agents

The data port allows access to memory via various caches. The choice of which cache to use for a given application is dictated by its restrictions, coherency issues, and how heavily that cache is used for other purposes.

The cache to use is selected by the shared function accessed.

Accessing Render Targets

Render targets are the surfaces that the final results of pixel shaders are written to. The render targets support a large set of surface formats (refer to surface formats table in *Sampling Engine* for details) with hardware conversion from the format delivered by the thread. The render target message also causes numerous side effects, including potentially alpha test, depth test, stencil test, alpha blend (which normally causes a read of the render target), and other functions. These functions are covered in the *Windower* chapter as some of them (depth/stencil test) are also partially done in the Windower.

The render target write messages are specifically for the use of pixel shader threads that are spawned by the windower, and may not be used by any other threads. This is due to the pixel scoreboard side-effects that sending of this message entails. The pixel scoreboard ensures that incorrect ordering of reads and writes to the same pixel does not occur.

Message Sequencing Summary

This section summarizes the sequencing that occurs for each legal render target write message. All messages have the M0 and M1 header registers if the header is present. If the header is not present, all registers below are renumbered starting with M0 where M2 appears. All cases not shown in this table are illegal.

Key:

s0, s1 = source 0, source 1

1/0 = slots 15:8

3/2 = slots 7:0

sZ = source depth

oM = oMask

Message Type	oMask Present	Source Depth Present	Source 0 Alpha Present	M2	M3	M4	M5	M6	M7	M8	M9	M10	M11	M12	M13	M14



Message Type	oMask Present	Source Depth Present	Source 0 Alpha Present	M2	M3	M4	M5	M6	M7	M8	M9	M10	M11	M12	M13	M14
000	0	0	0	1/0R	3/2R	1/0G	3/2G	1/0B	3/2B	1/0A	3/2A					
000	0	0	1	1/0s0A	3/2s0A	1/0R	3/2R	1/0G	3/2G	1/0B	3/2B	1/0A	3/2A			
000	0	1	0	1/0R	3/2R	1/0G	3/2G	1/0B	3/2B	1/0A	3/2A	1/0sZ	3/2sZ			
000	0	1	1	1/0s0A	3/2s0A	1/0R	3/2R	1/0G	3/2G	1/0B	3/2B	1/0A	3/2A	1/0sZ	3/2sZ	
000	1	0	0	oM	1/0R	3/2R	1/0G	3/2G	1/0B	3/2B	1/0A	3/2A				
000	1	0	1	1/0soA	3/2s0A	oM	1/0R	3/2R	1/0G	3/2G	1/0B	3/2B	1/0A	3/2A		
000	1	1	0	oM	1/0R	3/2R	1/0G	3/2G	1/0B	3/2B	1/0A	3/2A	1/0sZ	3/2sZ		
000	1	1	1	1/0s0A	3/2s0A	oM	1/0R	3/2R	1/0G	3/2G	1/0B	3/2B	1/0A	3/2A	1/0sZ	3/2sZ
001	0	0	0	RGBA												
001	1	0	0	oM	RGBA											
010	0	0	0	1/0s0R	1/0s0G	1/0s0B	1/0s0A	1/0s1R	1/0s1G	1/0s1B	1/0s1A					
010	0	1	0	1/0s0R	1/0s0G	1/0s0B	1/0s0A	1/0s1R	1/0s1G	1/0s1B	1/0s1A	1/0sZ				
010	1	0	0	oM	1/0s0R	1/0s0G	1/0s0B	1/0s0A	1/0s1R	1/0s1G	1/0s1B	1/0s1A				
010	1	1	0	oM	1/0s0R	1/0s0G	1/0s0B	1/0s0A	1/0s1R	1/0s1G	1/0s1B	1/0s1A	1/0sZ			
011	0	0	0	3/2s0R	3/2s0G	3/2s0B	3/2s0A	3/2s1R	3/2s1G	3/2s1B	3/2s1A					
011	0	1	0	3/2s0R	3/2s0G	3/2s0B	3/2s0A	3/2s1R	3/2s1G	3/2s1B	3/2s1A	3/2sZ				
011	1	0	0	oM	3/2s0R	3/2s0G	3/2s0B	3/2s0A	3/2s1R	3/2s1G	3/2s1B	3/2s1A				
011	1	1	0	oM	3/2s0R	3/2s0G	3/2s0B	3/2s0A	3/2s1R	3/2s1G	3/2s1B	3/2s1A	3/2sZ			
100	0	0	0	R	G	B	A									
100	0	0	1	s0A	R	G	B	A								
100	0	1	0	R	G	B	A	sZ								
100	0	1	1	s0A	R	G	B	A	sZ							
100	1	0	0	oM	R	G	B	A								
100	1	0	1	s0A	oM	R	G	B	A							
100	1	1	0	oM	R	G	B	A	sZ							
100	1	1	1	s0A	oM	R	G	B	A	sZ						



Single Source

The "normal" render target messages are single source. There are two forms, SIMD16 and SIMD8, intended for the equivalent-sized pixel shader threads. A single color (4 channels) is delivered for each of the 16 or 8 pixels in the message payload. Optional depth, stencil, and antialias alpha information can also be delivered with these messages.

The pixel scoreboard bits corresponding to the dispatched pixel mask (or half of the mask in the case of SIMD8 messages) are cleared only if the **Last Render Target Select** bit is set in the message descriptor.

The single source message does not cause a write to the render target if **Dual Source Blend Enable** in 3DSTATE_WM is *enabled*. However, if **Last Render Target Select** is set, the message still causes pixel scoreboard clear and depth/stencil buffer updates if enabled.

Dual Source

The dual source render target messages only have SIMD8 forms due to maximum message length limitations. SIMD16 pixel shaders must send two of these messages to cover all of the pixels. Each message contains two colors (4 channels each) for each pixel in the message payload. In addition to the first source, the second source can be selected as a blend factor (BLENDFACTOR_*_SRC1_* options in the blend factor fields of COLOR_CALC_STATE or BLEND_STATE). Optional depth, stencil, and antialias alpha information can also be delivered with these messages.

Each dual source message delivered clears the corresponding pixel scoreboard bits if the **Last Render Target Select** bit in the message descriptor is set.

The dual source message reverts to a single source message using source 0 if **Dual Source Blend Enable** in 3DSTATE_WM is disabled.



Replicate Data

The replicate data render target message is used for *fast clear* functionality in cases where the color data for each pixel is identical. This message performs better than the other messages due to its smaller message length. This message does not support depth, stencil, or antialias alpha data being sent with it. This message must target only tiled memory. Access of linear memory using this message type is UNDEFINED. The depth buffer can be cleared through the *early depth* function in conjunction with a pixel shader using this message. Refer to the *Windower* chapter for more details on the early depth function.

The pixel scoreboard bits corresponding to the dispatched pixel mask are cleared only if the **Last Render Target Select** bit is set in the message descriptor.

Multiple Render Targets (MRT)

Multiple render targets are supported with the single source and replicate data messages. Each render target is accessed with a separate Render Target Write message, each with a different surface indicated (different binding table index). The depth buffer is written only by the message(s) to the last render target, indicated by the **Last Render Target Select** bit set to clear the pixel scoreboard bits.

MRT is not supported when one or more RTs have any of these surface formats: YCRCB_SWAPUVY, YCRCB_SWAPUV, YCRCB_SWAPY, or YCRCB_NORMAL.

Render Target Read and Write

Render Target Write

This message takes four subspans of pixels for write to a render target. Depending on parameters contained in the message and state, it may also perform a depth and stencil buffer write and/or a render target read for a color blend operation. Additional operations enabled in the Color Calculator state are also initiated as a result of issuing this message (depth test, alpha test, logic ops, etc.). This message is intended only for use by pixel shader kernels for writing results to render targets.

General Restrictions

All surface types, except SURFTYPE_STRBUF, are allowed.

For SURFTYPE_BUFFER and SURFTYPE_1D surfaces, only the X coordinate is used to index into the surface. The Y coordinate must be zero.

For SURFTYPE_1D, 2D, 3D, and CUBE surfaces, a **Render Target Array Index** is included in the input message to provide an additional coordinate. The **Render Target Array Index** must be zero for SURFTYPE_BUFFER.

The surface format is restricted to the set supported as render target. If source/dest color blend is enabled, the surface format is further restricted to the set supported as alpha blend render target.

The last message sent to the render target by a thread must have the **End Of Thread** bit set in the message descriptor and the dispatch mask set correctly in the message header to enable correct clearing of the pixel scoreboard.



The stateless model cannot be used with this message (**Binding Table Index** cannot be 255).

This message can only be issued from a kernel specified in WM_STATE or 3DSTATE_WM (pixel shader kernel), dispatched in non-contiguous mode. Any other kernel issuing this message causes undefined behavior.

The dual source message cannot be used if the Render Target Rotation field in SURFACE_STATE is set to anything other than RTROTATE_0DEG.

This message cannot be used on a surface in field mode (**Vertical Line Stride** = 1).

If multiple SIMD8 Dual Source messages are delivered by the pixel shader thread, each SIMD8_DUALSRC_LO message must be issued *before* the SIMD8_DUALSRC_HI message with the same **Slot Group Select** setting.

Project-Specific Restrictions

Project	Restriction
	Execution Mask. The execution mask for render target messages is ignored. Control of which pixels are active is controlled by the Pixel/Sample Enables fields in the message header.
	Execution Mask. For messages without header, the execution mask for render target messages (sent as part of the channel enables on the obus sideband) is used to kill pixels.

Out-of-Bounds Accesses. Accesses to pixels outside of the surface are dropped and do not modify memory. However, if the **Render Target Array Index** is out of bounds, it is set to zero and the surface write is not suppressed.

The following table indicates the surface formats supported by this message with project restrictions and whether each format supports Alpha Blend.

Project	Surface Format Name	Alpha Blend?
	R32G32B32A32_FLOAT	Yes
	R32G32B32A32_SINT	No
	R32G32B32A32_UINT	No
	R16G16B16A16_UNORM	Yes
	R16G16B16A16_SNORM	Yes
	R16G16B16A16_SINT	No
	R16G16B16A16_UINT	No
	R16G16B16A16_FLOAT	Yes
	R32G32_FLOAT	Yes
	R32G32_SINT	No
	R32G32_UINT	No
	B8G8R8A8_UNORM	Yes
	B8G8R8A8_UNORM_SRGB	Yes
	R10G10B10A2_UNORM	Yes



Project	Surface Format Name	Alpha Blend?
	R10G10B10A2_UINT	No
	R8G8B8A8_UNORM	Yes
	R8G8B8A8_UNORM_SRGB	Yes
	R8G8B8A8_SNORM	Yes
	R8G8B8A8_SINT	No
	R8G8B8A8_UINT	No
	R16G16_UNORM	Yes
	R16G16_SNORM	Yes
	R16G16_SINT	No
	R16G16_UINT	No
	R16G16_FLOAT	Yes
	B10G10R10A2_UNORM	Yes
	B10G10R10A2_UNORM_SRGB	Yes
	R11G11B10_FLOAT	Yes
	R32_SINT	No
	R32_UINT	No
	R32_FLOAT	Yes
	B5G6R5_UNORM	Yes
	B5G6R5_UNORM_SRGB	Yes
	B5G5R5A1_UNORM	Yes
	B5G5R5A1_UNORM_SRGB	Yes
	B4G4R4A4_UNORM	Yes
	B4G4R4A4_UNORM_SRGB	Yes
	R8G8_UNORM	Yes
	R8G8_SNORM	Yes
	R8G8_SINT	No
	R8G8_UINT	No
	R16_UNORM	Yes
	R16_SNORM	Yes
	R16_SINT	No
	R16_UINT	No
	R16_FLOAT	Yes
	B5G5R5X1_UNORM	Yes
	B5G5R5X1_UNORM_SRGB	Yes
	R8_UNORM	Yes
	R8_SNORM	Yes
	R8_SINT	No
	R8_UINT	No
	A8_UNORM	Yes



Project	Surface Format Name	Alpha Blend?
	YCRCB_NORMAL	No
	YCRCB_SWAPUVY	No
	YCRCB_SWAPUV	No
	YCRCB_SWAPY	No

Subspan/Pixel to Slot Mapping

The following table indicates the mapping of subspans, pixels, and samples to slots in the pixel shader dispatch depending on the number of samples and message size. This table applies to all devices. However NumSamples = 4X is supported only on [DevGT+]. NumSamples = 8X is supported only on [HSW].

Pixels are numbered as follows within a subspan:

0 = upper left

1 = upper right

2 = lower left

3 = lower right

sspi = Starting Sample Pair Index (from the message header)

Dispatch Size	Num Samples	Slot Mapping (SSPI = Starting Sample Pair Index)
SIMD32	1X	Slot[3:0] = Subspan[0].Pixel[3:0].Sample[0] Slot[7:4] = Subspan[1].Pixel[3:0].Sample[0] Slot[11:8] = Subspan[2].Pixel[3:0].Sample[0] Slot[15:12] = Subspan[3].Pixel[3:0].Sample[0] Slot[19:16] = Subspan[4].Pixel[3:0].Sample[0] Slot[23:20] = Subspan[5].Pixel[3:0].Sample[0] Slot[27:24] = Subspan[6].Pixel[3:0].Sample[0] Slot[31:28] = Subspan[7].Pixel[3:0].Sample[0]
	2X	Slot[3:0] = Subspan[0].Pixel[3:0].Sample[0] Slot[7:4] = Subspan[0].Pixel[3:0].Sample[1] Slot[11:8] = Subspan[1].Pixel[3:0].Sample[0] Slot[15:12] = Subspan[1].Pixel[3:0].Sample[1] Slot[19:16] = Subspan[2].Pixel[3:0].Sample[0]



Dispatch Size	Num Samples	Slot Mapping (SSPI = Starting Sample Pair Index)
		Slot[23:20] = Subspan[2].Pixel[3:0].Sample[1] Slot[27:24] = Subspan[3].Pixel[3:0].Sample[0] Slot[31:28] = Subspan[3].Pixel[3:0].Sample[1]
	4X	Slot[3:0] = Subspan[0].Pixel[3:0].Sample[0] Slot[7:4] = Subspan[0].Pixel[3:0].Sample[1] Slot[11:8] = Subspan[0].Pixel[3:0].Sample[2] Slot[15:12] = Subspan[0].Pixel[3:0].Sample[3] Slot[19:16] = Subspan[1].Pixel[3:0].Sample[0] Slot[23:20] = Subspan[1].Pixel[3:0].Sample[1] Slot[27:24] = Subspan[1].Pixel[3:0].Sample[2] Slot[31:28] = Subspan[1].Pixel[3:0].Sample[3]
SIMD16	8X	Slot[3:0] = Subspan[0].Pixel[3:0].Sample[0] Slot[7:4] = Subspan[0].Pixel[3:0].Sample[1] Slot[11:8] = Subspan[0].Pixel[3:0].Sample[2] Slot[15:12] = Subspan[0].Pixel[3:0].Sample[3] Slot[19:16] = Subspan[0].Pixel[3:0].Sample[4] Slot[23:20] = Subspan[0].Pixel[3:0].Sample[5] Slot[27:24] = Subspan[0].Pixel[3:0].Sample[6] Slot[31:28] = Subspan[0].Pixel[3:0].Sample[7]
	1X	Slot[3:0] = Subspan[0].Pixel[3:0].Sample[0] Slot[7:4] = Subspan[1].Pixel[3:0].Sample[0] Slot[11:8] = Subspan[2].Pixel[3:0].Sample[0] Slot[15:12] = Subspan[3].Pixel[3:0].Sample[0]
	2X	Slot[3:0] = Subspan[0].Pixel[3:0].Sample[0] Slot[7:4] = Subspan[0].Pixel[3:0].Sample[1] Slot[11:8] = Subspan[1].Pixel[3:0].Sample[0] Slot[15:12] = Subspan[1].Pixel[3:0].Sample[1]

Restriction:



When SIMD32 or SIMD16 PS threads send render target writes with multiple SIMD8 and SIMD16 messages, the following must hold:

All the slots (as described above) must have a corresponding render target write irrespective of the slot's validity. A slot is considered valid when at least one sample is enabled. For example, a SIMD16 PS thread must send two SIMD8 render target writes to cover all the slots.

PS thread must send SIMD render target write messages with increasing slot numbers. For example, SIMD16 thread has Slot[15:0] and if two SIMD8 render target writes are used, the first SIMD8 render target write must send Slot[7:0] and the next one must send Slot[15:8].

Message Descriptor

This section contains descriptors for the render target read and write functions.

Message Descriptor - Render Target Write

Message Header

The render target write message has a two-register message header.

Message Header

DWord	Bit	Description																																
M0.7	31:0																																	
M0.6	31:0																																	
M0.5	31:8	Ignored																																
	7:0	Dispatch ID. This ID is assigned by the fixed function unit and is a unique identifier for the thread. It is used to free up resources used by the thread upon thread completion.																																
M0.4	31:0	Ignored (reserved for hardware delivery of binding table pointer)																																
M0.3	31:0	Ignored																																
M0.2	31:0	<p>Pixel Mask. One bit per pixel indicating which pixels are lit, possibly impacted by kill instruction activity in the pixel shader. This mask is used to control actual writes to the color buffer. This field is ignored by the read message, all pixels are always returned.</p> <p>The bits in this mask correspond to the pixels as follows:</p> <table border="1" style="margin-left: 20px;"> <tbody> <tr> <td>0</td><td>1</td><td>4</td><td>5</td><td>16</td><td>17</td><td>20</td><td>21</td> </tr> <tr> <td>2</td><td>3</td><td>6</td><td>7</td><td>18</td><td>19</td><td>22</td><td>23</td> </tr> <tr> <td>8</td><td>9</td><td>12</td><td>13</td><td>24</td><td>25</td><td>28</td><td>29</td> </tr> <tr> <td>10</td><td>11</td><td>14</td><td>15</td><td>26</td><td>27</td><td>30</td><td>31</td> </tr> </tbody> </table>	0	1	4	5	16	17	20	21	2	3	6	7	18	19	22	23	8	9	12	13	24	25	28	29	10	11	14	15	26	27	30	31
0	1	4	5	16	17	20	21																											
2	3	6	7	18	19	22	23																											
8	9	12	13	24	25	28	29																											
10	11	14	15	26	27	30	31																											



DWord	Bit	Description
M0.1	31:0	Y offset. The Y offset of the upper left corner of the block into the surface. Must be 4-row aligned (Bits 1:0 MBZ). Format = S31
M0.0	31:0	X offset. The X offset of the upper left corner of the block into the surface. This is a pixel offset assuming a 32-bit pixel. Must be 8-pixel aligned (Bits 2:0 MBZ). Format = S31

Writeback Message (Read)

A SIMD16 writeback message consists of up to 8 destination registers. If a channel/component is not present in the RT format, the corresponding GRF is filled with zeroes or 1.0 in float/int depending on whether RGB or Alpha are disabled.

DWord	Bits	Description
W0.7	31:0	Slot 7 Red. Specifies the value of the red channel for slot 7. Format = 32 bits raw data.
W0.6	31:0	Slot 6 Red
W0.5	31:0	Slot 5 Red
W0.4	31:0	Slot 4 Red
W0.3	31:0	Slot 3 Red
W0.2	31:0	Slot 2 Red
W0.1	31:0	Slot 1 Red
W0.0	31:0	Slot 0 Red
W1.7	31:0	Slot 15 Red
W1.6	31:0	Slot 14 Red
W1.5	31:0	Slot 13 Red
W1.4	31:0	Slot 12 Red
W1.3	31:0	Slot 11 Red
W1.2	31:0	Slot 10 Red
W1.1	31:0	Slot 9 Red
W1.0	31:0	Slot 8 Red
W2		Slots 7:0 Green
W3		Slots 15:8 Green
W4		Slots 7:0 Blue
W5		Slots 15:8 Blue



DWord	Bits	Description
W6		Slots 7:0 Alpha
W7		Slots 15:8 Alpha

A SIMD8 writeback message consists of up to 4 destination registers. Which registers are returned is determined by the channel mask in the message descriptor. Each asserted channel mask results in the destination register of the corresponding channel being filled with zeroes or 1.0 in float/int depending on whether RGB or Alpha are disabled.

DWord	Bits	Description
W0.7	31:0	Slot 7 Red. Specifies the value of the red channel for slot 7. Format = 32 bits raw data.
W0.6	31:0	Slot 6 Red
W0.5	31:0	Slot 5 Red
W0.4	31:0	Slot 4 Red
W0.3	31:0	Slot 3 Red
W0.2	31:0	Slot 2 Red
W0.1	31:0	Slot 1 Red
W0.0	31:0	Slot 0 Red
W1		Slots 7:0 Green
W2		Slots 7:0 Blue
W3		Slots 7:0 Alpha



Header for SIMD8_IMAGE_WRITE

DWord	Bit	Description
M0.7	31:0	
M0.6	31:0	
M0.5	31:10	Ignored
	9:8	Color Code: This ID is assigned by the Windower unit and is used to track synchronizing events. Format: Reserved for HW Implementation Use.
	7:0	FFTID. The Fixed Function Thread ID is assigned by the fixed function unit and is a unique identifier for the thread. It is used to free up resources used by the thread upon thread completion.
M0.4	31:0	Ignored (reserved for hardware delivery of binding table pointer)
M0.3	31:0	Ignored
M0.2	31:3	Ignored
	2:0	Render Target Index. Specifies the render target index that will be used to select blend state from BLEND_STATE. Format = U3
M0.1	31:6	ColorCalculatorState Pointer. Specifies the 64-byte aligned pointer to the color calculator state. This pointer is relative to the General State Base Address . Format = GeneralStateOffset[31:6] For SIMD8_IMAGE_WR message under normal GPGPU usage model, SW is recommended to program a dummy color-calc state such that all operations controlled by this state are disabled.
	5:0	Ignored
M0.0	31	Ignored
	30:27	Viewport Index. Specifies the index of the viewport currently being used. Format = U4 Range = [0,15] SIMD8_IMAGE_WR message type this field is ignored by hardware.



DWord	Bit	Description														
	26:16	<p>Render Target Array Index. Specifies the array index to be used for the following surface types:</p> <p>SURFTYPE_1D: specifies the array index. Range = [0,511]</p> <p>SURFTYPE_2D: specifies the array index. Range = [0,511]</p> <p>SURFTYPE_3D: specifies the z or r coordinate. Range = [0,2047]</p> <p>SURFTYPE_CUBE: specifies the face identifier. Range = [0,5]</p> <p>SURFTYPE_BUFFER: must be zero.</p> <table border="1" data-bbox="406 625 821 940"> <thead> <tr> <th>face</th> <th>Render Target Array Index</th> </tr> </thead> <tbody> <tr> <td>+x</td> <td>0</td> </tr> <tr> <td>-x</td> <td>1</td> </tr> <tr> <td>+y</td> <td>2</td> </tr> <tr> <td>-y</td> <td>3</td> </tr> <tr> <td>+z</td> <td>4</td> </tr> <tr> <td>-z</td> <td>5</td> </tr> </tbody> </table> <p>Format = U11</p> <p>The Render Target Array Index used by hardware for access to the Render Target is overridden with the Minimum Array Element defined in SURFACE_STATE if it is out of the range between Minimum Array Element and Depth. For cube surfaces, a depth value of 5 is used for this determination.</p> <p>For SMD8_IMAGE_WRITE :</p> <p>For SURFTYPE_2D, this field must be 0.</p> <p>For SURFTYPE_3D, this field may not be 0 for "Write-3D-Image" operation.</p>	face	Render Target Array Index	+x	0	-x	1	+y	2	-y	3	+z	4	-z	5
face	Render Target Array Index															
+x	0															
-x	1															
+y	2															
-y	3															
+z	4															
-z	5															
	15:8	Ignored														
	7:0	<p>Pixel Maks for SIMD8 messages.</p> <p>1: Pixel is enabled</p> <p>0: Pixel is disabled , in this case the corresponding (x,y) should be ignored by hardware.</p>														
M1.7	31:16	<p>Y7: y-coordinate for pixel 7</p> <p>Format = U16</p>														
	15:0	<p>X7: x-coordinate for pixel 7</p> <p>Format = U16</p>														
M1.6	31:16	<p>Y6: y-coordinate for pixel 6</p> <p>Format = U16</p>														
	15:0	<p>X6: x-coordinate for pixel 6</p> <p>Format = U16</p>														
M1.5	31:16	<p>Y5: y-coordinate for pixel 5</p> <p>Format = U16</p>														



DWord	Bit	Description
	15:0	X5: x-coordinate for pixel 5 Format = U16
M1.4	31:16	Y4: y-coordinate for pixel 4 Format = U16
	15:0	X4: x-coordinate for pixel 4 Format = U16
M1.3	31:16	Y3: y-coordinate for pixel 3 Format = U16
	15:0	X3: x-coordinate for pixel 3 Format = U16
M1.2	31:16	Y2: y-coordinate for pixel 2 Format = U16
	15:0	X2: x-coordinate for pixel 2 Format = U16
M1.1	31:16	Y1: y-coordinate for pixel 1 Format = U16
	15:0	X1: x-coordinate for pixel 1 Format = U16
M1.0	31:16	Y0: y-coordinate for pixel 0 Format = U16
	15:0	X0: x-coordinate for pixel 0 Format = U16



Source 0 Alpha Payload

The source 0 alpha registers, if included, appear in M2 and M3, immediately following the header (if present).

For the SIMD8 single source message, only slot 7:0 data is sent (M2). The source 0 alpha phases are not supported for dual source messages.

DWord	Bit	Description
M2.7	31:0	Source 0 Alpha for Slot 7 Format = IEEE_Float This and the next register is only included if Source 0 Alpha Present bit is set.
M2.6	31:0	Source 0 Alpha for Slot 6
M2.5	31:0	Source 0 Alpha for Slot 5
M2.4	31:0	Source 0 Alpha for Slot 4
M2.3	31:0	Source 0 Alpha for Slot 3
M2.2	31:0	Source 0 Alpha for Slot 2
M2.1	31:0	Source 0 Alpha for Slot 1
M2.0	31:0	Source 0 Alpha for Slot 0
M3.7	31:0	Source 0 Alpha for Slot 15
M3.6	31:0	Source 0 Alpha for Slot 14
M3.5	31:0	Source 0 Alpha for Slot 13
M3.4	31:0	Source 0 Alpha for Slot 12
M3.3	31:0	Source 0 Alpha for Slot 11
M3.2	31:0	Source 0 Alpha for Slot 10
M3.1	31:0	Source 0 Alpha for Slot 9
M3.0	31:0	Source 0 Alpha for Slot 8



oMask Payload

The oMask payload, if present, follows source 0 alpha. The value of p depends on whether the header and source 0 alpha are present.

Sample n for that pixel will be killed (not written to the render target or depth buffer) if bit n of the oMask is zero. Bits numbers where n is larger than the number of multisamples are ignored.

For the SIMD8 messages, only slots 7:0 data is used, or only slots 15:8 depending on the **Message Type** encoding.

DWord	Bit	Description
Mp.7	31:16	oMask for Slot 15 Format = 16-bit mask This register is only included if oMask Present bit is set.
	15:0	oMask for Slot 14
Mp.6	31:16	oMask for Slot 13
	15:0	oMask for Slot 12
Mp.5	31:16	oMask for Slot 11
	15:0	oMask for Slot 10
Mp.4	31:16	oMask for Slot 9
	15:0	oMask for Slot 8
Mp.3	31:16	oMask for Slot 7
	15:0	oMask for Slot 6
Mp.2	31:16	oMask for Slot 5
	15:0	oMask for Slot 4
Mp.1	31:16	oMask for Slot 3
	15:0	oMask for Slot 2
Mp.0	31:16	oMask for Slot 1
	15:0	oMask for Slot 0



Color Payload: SIMD16 Single Source

Color Payload

This payload is included if the Message Type is SIMD16 single source. The value of 'm' depends on whether the header, source 0 alpha, and oMask are present.

DWord	Bits	Description
Mm.7	31:0	Slot 7 Red. Specifies the value of the slot's red component. Format = IEEE Float, S31, or U32 depending on the Surface Format of the surface being accessed. SINT formats use S31, UINT formats use U32, and all other formats use Float.
Mm.6	31:0	Slot 6 Red
Mm.5	31:0	Slot 5 Red
Mm.4	31:0	Slot 4 Red
Mm.3	31:0	Slot 3 Red
Mm.2	31:0	Slot 2 Red
Mm.1	31:0	Slot 1 Red
Mm.0	31:0	Slot 0 Red
M(m+1).7	31:0	Slot 15 Red
M(m+1).6	31:0	Slot 14 Red
M(m+1).5	31:0	Slot 13 Red
M(m+1).4	31:0	Slot 12 Red
M(m+1).3	31:0	Slot 11 Red
M(m+1).2	31:0	Slot 10 Red
M(m+1).1	31:0	Slot 9 Red
M(m+1).0	31:0	Slot 8 Red
M(m+2)		Slot[7:0] Green. See Mm definition for slot locations.
M(m+3)		Slot[15:8] Green. See M(m+1) definition for slot locations.
M(m+4)		Slot[7:0] Blue. See Mm definition for slot locations.
M(m+5)		Slot[15:8] Blue. See M(m+1) definition for slot locations.
M(m+6)		Slot[7:0] Alpha. See Mm definition for slot locations.
M(m+7)		Slot[15:8] Alpha. See M(m+1) definition for slot locations.



Color Payload: SIMD8 Single Source

This payload is included if the Message Type is SIMD8 single source or SIMD8 Image Write. The value of m depends on whether the header, source 0 alpha, and oMask are present.

DWord	Bit	Description
Mm.7	31:0	Slot 7 Red. Specifies the value of the slot's red component. Format = IEEE Float, S31, or U32 depending on the Surface Format of the surface being accessed. SINT formats use S31, UINT formats use U32, and all other formats use Float.
Mm.6	31:0	Slot 6 Red
Mm.5	31:0	Slot 5 Red
Mm.4	31:0	Slot 4 Red
Mm.3	31:0	Slot 3 Red
Mm.2	31:0	Slot 2 Red
Mm.1	31:0	Slot 1 Red
Mm.0	31:0	Slot 0 Red
M(m+1)		Slot[7:0] Green. See Mm definition for slot locations
M(m+2)		Slot[7:0] Blue. See Mm definition for slot locations
M(m+3)		Slot[7:0] Alpha. See Mm definition for slot locations



Color Payload SIMD16 Replicated Data

This payload is included if the Message Type specifies a single source message with replicated data. One set of R/G/B/A data is included in the message, and this data is replicated to all 16 pixels.

This message is legal with color data; oMask is also legal with this message. The registers for depth, stencil, and antialias alpha data cannot be included with this message, and the corresponding bits in the message header must indicate that these registers are not present.

The value of 'm' depends on whether the header and oMask are present.

Note: This message is allowed only on tiled surfaces.

DWord	Bits	Description
Mm.7:4	31:0	Reserved
Mm.3	31:0	Alpha. Specifies the value of the alpha channel for all slots. Format = IEEE Float, S31, or U32 depending on the Surface Format of the surface being accessed. SINT formats use S31, UINT formats use U32, and all other formats use Float.
Mm.2	31:0	Blue
Mm.1	31:0	Green
Mm.0	31:0	Red

Color Payload SIMD8 Dual Source

This payload is included if the **Message Type** specifies dual source message. The value of 'm' depends on whether the header, source 0 alpha, and oMask are present.

The dual source message contains only 2 subspans (8 pixels) due to limitations in message length.

DWord	Bits	Description
Mm.7	31:0	Slot 7 Source 0 Red. Specifies the value of the slot's red component. Format = IEEE Float, S31, or U32 depending on the Surface Format of the surface being accessed. SINT formats use S31, UINT formats use U32, and all other formats use Float.
Mm.6	31:0	Slot 6 Source 0 Red
Mm.5	31:0	Slot 5 Source 0 Red
Mm.4	31:0	Slot 4 Source 0 Red
Mm.3	31:0	Slot 3 Source 0 Red
Mm.2	31:0	Slot 2 Source 0 Red
Mm.1	31:0	Slot 1 Source 0 Red
Mm.0	31:0	Slot 0 Source 0 Red
M(m+1)		Slot[7:0] Source 0 Green. See Mm definition for slot locations.



DWord	Bits	Description
M(m+2)		Slot[7:0] Source 0 Blue. See Mm definition for slot locations.
M(m+3)		Slot[7:0] Source 0 Alpha. See Mm definition for slot locations.
M(m+4)		Slot[7:0] Source 1 Red. See Mm definition for slot locations.
M(m+5)		Slot[7:0] Source 1 Green. See Mm definition for slot locations.
M(m+6)		Slot[7:0] Source 1 Blue. See Mm definition for slot locations.
M(m+7)		Slot[7:0] Source 1 Alpha. See Mm definition for slot locations.



Message Sequencing Summary

Message Sequencing Summary

This section summarizes the sequencing that occurs for each legal render target write message. All messages have the M0 and M1 header registers if the header is present. If the header is not present, all registers below are renumbered starting with M0 where M2 appears. All cases not shown in this table are illegal.

Key:

s0, s1 = source 0, source 1

1/0 = slots 15:8

3/2 = slots 7:0

sZ = source depth

oM = oMask

Message Type	oMask Present	Source Depth Present	Source 0 Alpha Present	M2	M3	M4	M5	M6	M7	M8	M9	M10	M11	M12	M13	M14
000	0	0	0	1/0R	3/2R	1/0G	3/2G	1/0B	3/2B	1/0A	3/2A					
000	0	0	1	1/0s0A	3/2s0A	1/0R	3/2R	1/0G	3/2G	1/0B	3/2B	1/0A	3/2A			
000	0	1	0	1/0R	3/2R	1/0G	3/2G	1/0B	3/2B	1/0A	3/2A	1/0sZ	3/2sZ			
000	0	1	1	1/0s0A	3/2s0A	1/0R	3/2R	1/0G	3/2G	1/0B	3/2B	1/0A	3/2A	1/0sZ	3/2sZ	
000	1	0	0	oM	1/0R	3/2R	1/0G	3/2G	1/0B	3/2B	1/0A	3/2A				
000	1	0	1	1/0soA	3/2s0A	oM	1/0R	3/2R	1/0G	3/2G	1/0B	3/2B	1/0A	3/2A		
000	1	1	0	oM	1/0R	3/2R	1/0G	3/2G	1/0B	3/2B	1/0A	3/2A	1/0sZ	3/2sZ		
000	1	1	1	1/0s0A	3/2s0A	oM	1/0R	3/2R	1/0G	3/2G	1/0B	3/2B	1/0A	3/2A	1/0sZ	3/2sZ
001	0	0	0	RGBA												
001	1	0	0	oM	RGBA											
010	0	0	0	1/0s0R	1/0s0G	1/0s0B	1/0s0A	1/0s1R	1/0s1G	1/0s1B	1/0s1A					
010	0	1	0	1/0s0R	1/0s0G	1/0s0B	1/0s0A	1/0s1R	1/0s1G	1/0s1B	1/0s1A	1/0sZ				
010	1	0	0	oM	1/0s0R	1/0s0G	1/0s0B	1/0s0A	1/0s1R	1/0s1G	1/0s1B	1/0s1A				
010	1	1	0	oM	1/0s0R	1/0s0G	1/0s0B	1/0s0A	1/0s1R	1/0s1G	1/0s1B	1/0s1A	1/0sZ			
011	0	0	0	3/2s0R	3/2s0G	3/2s0B	3/2s0A	3/2s1R	3/2s1G	3/2s1B	3/2s1A					



Message Type	oMask Present	Source Depth Present	Source 0 Alpha Present	M2	M3	M4	M5	M6	M7	M8	M9	M10	M11	M12	M13	M14
011	0	1	0	3/2s0R	3/2s0G	3/2s0B	3/2s0A	3/2s1R	3/2s1G	3/2s1B	3/2s1A	3/2sZ				
011	1	0	0	oM	3/2s0R	3/2s0G	3/2s0B	3/2s0A	3/2s1R	3/2s1G	3/2s1B	3/2s1A				
011	1	1	0	oM	3/2s0R	3/2s0G	3/2s0B	3/2s0A	3/2s1R	3/2s1G	3/2s1B	3/2s1A	3/2sZ			
100	0	0	0	R	G	B	A									
100	0	0	1	s0A	R	G	B	A								
100	0	1	0	R	G	B	A	sZ								
100	0	1	1	s0A	R	G	B	A	sZ							
100	1	0	0	oM	R	G	B	A								
100	1	0	1	s0A	oM	R	G	B	A							
100	1	1	0	oM	R	G	B	A	sZ							
100	1	1	1	s0A	oM	R	G	B	A	sZ						

Render Target Read and Write

Render Target Write

This message takes four subspans of pixels for write to a render target. Depending on parameters contained in the message and state, it may also perform a depth and stencil buffer write and/or a render target read for a color blend operation. Additional operations enabled in the Color Calculator state are also initiated as a result of issuing this message (depth test, alpha test, logic ops, etc.). This message is intended only for use by pixel shader kernels for writing results to render targets.

General Restrictions

All surface types, except SURFTYPE_STRBUF, are allowed.

For SURFTYPE_BUFFER and SURFTYPE_1D surfaces, only the X coordinate is used to index into the surface. The Y coordinate must be zero.

For SURFTYPE_1D, 2D, 3D, and CUBE surfaces, a **Render Target Array Index** is included in the input message to provide an additional coordinate. The **Render Target Array Index** must be zero for SURFTYPE_BUFFER.

The surface format is restricted to the set supported as render target. If source/dest color blend is enabled, the surface format is further restricted to the set supported as alpha blend render target.

The last message sent to the render target by a thread must have the **End Of Thread** bit set in the message descriptor and the dispatch mask set correctly in the message header to enable correct clearing of the pixel scoreboard.

The stateless model cannot be used with this message (**Binding Table Index** cannot be 255).



This message can only be issued from a kernel specified in WM_STATE or 3DSTATE_WM (pixel shader kernel), dispatched in non-contiguous mode. Any other kernel issuing this message causes undefined behavior.

The dual source message cannot be used if the Render Target Rotation field in SURFACE_STATE is set to anything other than RTROTATE_0DEG.

This message cannot be used on a surface in field mode (**Vertical Line Stride** = 1).

If multiple SIMD8 Dual Source messages are delivered by the pixel shader thread, each SIMD8_DUALSRC_LO message must be issued *before* the SIMD8_DUALSRC_HI message with the same **Slot Group Select** setting.

Project-Specific Restrictions

Project	Restriction
	Execution Mask. The execution mask for render target messages is ignored. Control of which pixels are active is controlled by the Pixel/Sample Enables fields in the message header.
	Execution Mask. For messages without header, the execution mask for render target messages (sent as part of the channel enables on the obus sideband) is used to kill pixels.

Out-of-Bounds Accesses. Accesses to pixels outside of the surface are dropped and do not modify memory. However, if the **Render Target Array Index** is out of bounds, it is set to zero and the surface write is not suppressed.

The following table indicates the surface formats supported by this message with project restrictions and whether each format supports Alpha Blend.

Project	Surface Format Name	Alpha Blend?
	R32G32B32A32_FLOAT	Yes
	R32G32B32A32_SINT	No
	R32G32B32A32_UINT	No
	R16G16B16A16_UNORM	Yes
	R16G16B16A16_SNORM	Yes
	R16G16B16A16_SINT	No
	R16G16B16A16_UINT	No
	R16G16B16A16_FLOAT	Yes
	R32G32_FLOAT	Yes
	R32G32_SINT	No
	R32G32_UINT	No
	B8G8R8A8_UNORM	Yes
	B8G8R8A8_UNORM_SRGB	Yes
	R10G10B10A2_UNORM	Yes
	R10G10B10A2_UINT	No
	R8G8B8A8_UNORM	Yes



Project	Surface Format Name	Alpha Blend?
	R8G8B8A8_UNORM_SRGB	Yes
	R8G8B8A8_SNORM	Yes
	R8G8B8A8_SINT	No
	R8G8B8A8_UINT	No
	R16G16_UNORM	Yes
	R16G16_SNORM	Yes
	R16G16_SINT	No
	R16G16_UINT	No
	R16G16_FLOAT	Yes
	B10G10R10A2_UNORM	Yes
	B10G10R10A2_UNORM_SRGB	Yes
	R11G11B10_FLOAT	Yes
	R32_SINT	No
	R32_UINT	No
	R32_FLOAT	Yes
	B5G6R5_UNORM	Yes
	B5G6R5_UNORM_SRGB	Yes
	B5G5R5A1_UNORM	Yes
	B5G5R5A1_UNORM_SRGB	Yes
	B4G4R4A4_UNORM	Yes
	B4G4R4A4_UNORM_SRGB	Yes
	R8G8_UNORM	Yes
	R8G8_SNORM	Yes
	R8G8_SINT	No
	R8G8_UINT	No
	R16_UNORM	Yes
	R16_SNORM	Yes
	R16_SINT	No
	R16_UINT	No
	R16_FLOAT	Yes
	B5G5R5X1_UNORM	Yes
	B5G5R5X1_UNORM_SRGB	Yes
	R8_UNORM	Yes
	R8_SNORM	Yes
	R8_SINT	No
	R8_UINT	No
	A8_UNORM	Yes
	YCRCB_NORMAL	No
	YCRCB_SWAPUVY	No



Project	Surface Format Name	Alpha Blend?
	YCRCB_SWAPUV	No
	YCRCB_SWAPY	No

Message Header

DWord	Bit	Description																																
M0.7	31:0																																	
M0.6	31:0																																	
M0.5	31:8	Ignored																																
	7:0	Dispatch ID. This ID is assigned by the fixed function unit and is a unique identifier for the thread. It is used to free up resources used by the thread upon thread completion.																																
M0.4	31:0	Ignored (reserved for hardware delivery of binding table pointer)																																
M0.3	31:0	Ignored																																
M0.2	31:0	<p>Pixel Mask. One bit per pixel indicating which pixels are lit, possibly impacted by kill instruction activity in the pixel shader. This mask is used to control actual writes to the color buffer. This field is ignored by the read message, all pixels are always returned.</p> <p>The bits in this mask correspond to the pixels as follows:</p> <table border="1" style="margin-left: 40px;"> <tbody> <tr> <td>0</td><td>1</td><td>4</td><td>5</td><td>16</td><td>17</td><td>20</td><td>21</td> </tr> <tr> <td>2</td><td>3</td><td>6</td><td>7</td><td>18</td><td>19</td><td>22</td><td>23</td> </tr> <tr> <td>8</td><td>9</td><td>12</td><td>13</td><td>24</td><td>25</td><td>28</td><td>29</td> </tr> <tr> <td>10</td><td>11</td><td>14</td><td>15</td><td>26</td><td>27</td><td>30</td><td>31</td> </tr> </tbody> </table>	0	1	4	5	16	17	20	21	2	3	6	7	18	19	22	23	8	9	12	13	24	25	28	29	10	11	14	15	26	27	30	31
0	1	4	5	16	17	20	21																											
2	3	6	7	18	19	22	23																											
8	9	12	13	24	25	28	29																											
10	11	14	15	26	27	30	31																											
M0.1	31:0	<p>Y offset. The Y offset of the upper left corner of the block into the surface. Must be 4-row aligned (Bits 1:0 MBZ).</p> <p>Format = S31</p>																																
M0.0	31:0	<p>X offset. The X offset of the upper left corner of the block into the surface. This is a pixel offset assuming a 32-bit pixel. Must be 8-pixel aligned (Bits 2:0 MBZ).</p> <p>Format = S31</p>																																



Cache Agents

The data port allows access to memory via various caches. The choice of which cache to use for a given application is dictated by its restrictions, coherency issues, and how heavily that cache is used for other purposes.

The cache to use is selected by the shared function accessed.

Skin Tone Detection/Enhancement (STD/E)

The STD/E unit, composed of the Skin Tone Detection (STD) and Skin Tone Enhancement (STE) units, is part of color processing pipe located at the Render Cache Pixel Backend (RCBP).

The main goal of the STD/E is to reproduce the skin colors in a way that is more palatable to the observer, and by that to increase the sensed image quality. It may also pass indication of skin tones to the TCC and ACE.

The STD unit detects the skin like colors and passes a grade of skin tone color to the STE. The STE modify the saturation and Hue of the pixel. Both the STD and STE are per-pixel basis. The input pixels are required to be on the YUV space.

The skin tone detected factor will be recorded as a 5-bit number and it will be passed to the module of ACE and TCC to indicate the strength of skin tone likelihood.

Input and output pixel is 444 format and 12bits per channel. Precision=12; Prec_shift = 4

STD

Skin Tone Detection (STD) module is turned on with state parameter *STD Enable*. The output of STD can be either the original pixel values or the skin tone likelihood score (STD score) for every pixel, and the selection of the output type is controlled by *Output Control*.

The distribution of skin color can be viewed statistically as a cluster spanning in the 3D YUV domain where the center of the cluster is considered as the 'exact' skin tone value. The detection of such 3D cluster can be done by taking the intersection of its projections onto three planes (that is, UV, YV, and YU).

While the distribution of skin color can roughly result in an ellipse shape from projection on UV plane, a rectangle and a diamond shape in a transformed coordinate (i.e., saturation hue (SH) domain) are utilized by STD block to approximate the shape of the projection to facilitate the detection of the projection in UV plane. The likelihood of a pixel being a skin color pixel in UV plane, *likelihood_uv* is then calculated from a function modeling the distance relationship between an input pixel and the transformed/projected skin tone center in the enclosure of the rectangle and the diamond shape. Several state parameters are involved in the derivation of *likelihood_uv*:

- $\text{Cos}(\alpha)$, $\text{Sin}(\alpha)$: parameters for UV to SH transformation
- U_Mid , V_Mid : configurable UV values of the pixel considered to be the skin tone center; center of the rectangle



- *Hue_Max, Sat_Max*: parameters specifying the coverage of the rectangle (thus, the range of SH values to be considered possibly as skin tone color)
- *HS_margin*: parameter indicating the transition rate of skin tone likelihood score as a pixel moves towards the center of the rectangle
- *Diamond_du, Diamond_dv*: shift amount between the center of the diamond shape and that of the rectangle
- *Diamond_alpha, Diamond_Th*: parameters specifying the size and the shape of the diamond
- *Diamond Margin*: parameter indicating the transition rate of skin tone likelihood score as a pixel moves towards the center of the diamond

The projection of the 3D skin color cluster on YU is further simplified to be a 1D projection over Y axis where the skin likelihood score *likelihood_yu* is derived from one Piece-Wise-Linear-Function (PWLF) mapping input pixel's Y value to the likelihood score. Four control points (*Y_point_1, Y_point_2, Y_point_3, Y_point_4*) together with two slopes (*Y_Slope_1, Y_Slope_2*) are available to SW for characterizing this PWLF. While (*Y_point_1, Y_point_2, Y_point_3, Y_point_4*) would specify the range of Y values considered valid for skin tone color, (*Y_Slope_1, Y_Slope_2*) would be the transition rate of the skin likelihood score as the change of a pixel's Y value within the valid range.

The projection of the 3D skin color cluster on YV plan is approximated be covered by an enclosure of two PWLFs (i.e., upper PWLF and lower PWLF). The calculation of *likelihood_yv* is similar to the calculation of *likelihood_uv*: the likelihood would be zero for pixels fall outside the enclosure of the two PWLFs while the likelihood value increases from zero to one (in normalized scale) as the pixels inside the enclosure moves towards the center of the enclosure. External state parameters involved in the derivation of *likelihood_yv* are:

- (*P0L, B0L*), (*P1L, B1L*), (*P2L, B2L*), (*P3L, B3L*): control points for lower PWLF
- *S0L, S1L, S2L, S3L*: slopes for lower PWLF
- (*P0U, B0U*), (*P1U, B1U*), (*P2U, B2U*), (*P3U, B3U*): control points for upper PWLF
- *S0U, S1U, S2U, S3U*: slopes for upper PWLF
- *INV_Margin_VYL*: parameter indicating the transition rate of skin tone likelihood score as a pixel within the enclosure moves towards the center of the enclosure viewed from the lower PWLF point of view
- *INV_Margin_VYU*: parameter indicating the transition rate of skin tone likelihood score as a pixel within the enclosure moves towards the center of the enclosure viewed from the upper PWLF point of view

The final skin tone likelihood score, STD score, is taken as an intersection of the likelihood score in UV, YU, and YV plane. That is

$$\text{STD_score} = \min(\text{likelihood_uv}, \text{likelihood_yu}, \text{likelihood_yv})$$

STD score is represented as a 5bps integer number. Note that the detection of skin tone color in YV plane is controlled by the state parameter **VY_STD_Enable**, and it is optional. When the detection in YV plane is turned off, STD score is taken as the intersection of *likelihood_uv* and *likelihood_yu*.



Skin Tone Enhancement

The Skin Tone Enhancement step is performed on the pixels that are detected as the skin-tone pixels by the Skin Tone Detection (STD) step. The Skin Tone Enhancement step is divided into two sub-steps: Saturation Correction Enhancement and Hue Correction Enhancement.

Saturation Correction Enhancement

The saturation correction enhancement is performed by the transformation $Sat_{New} = F_{Sat}(Sat_{Old})$, which is realized by the piece-wise linear function F_{Sat} with 4 linear segments.

The parameters of this PWLF are:

- Points:
 $SATP0 = -SatMax$
 $SATPx(x=1,2,3)$ – defined by the user
 $SATP4 = SatMax$
- Biases:
 $SATB0 = -SatMax$
 $SATBx(x=1,2,3)$ – defined by the user
 $SATB4 = SatMax$
- Slopes:
 $SATSx(x=0,1,2,3)$ – defined by the user

There are Programming Restrictions to specify the parameters. (See the figure below for an example.)

- The point $Sat = -Sat_{Max}$ maps to itself: $(-Sat_{Max}) \rightarrow (-Sat_{Max})$.
- The point $Sat = Sat_{Max}$ maps to itself: $(Sat_{Max}) \rightarrow (Sat_{Max})$.
- The correction function is continuous.
- The correction function is non-decreasing.

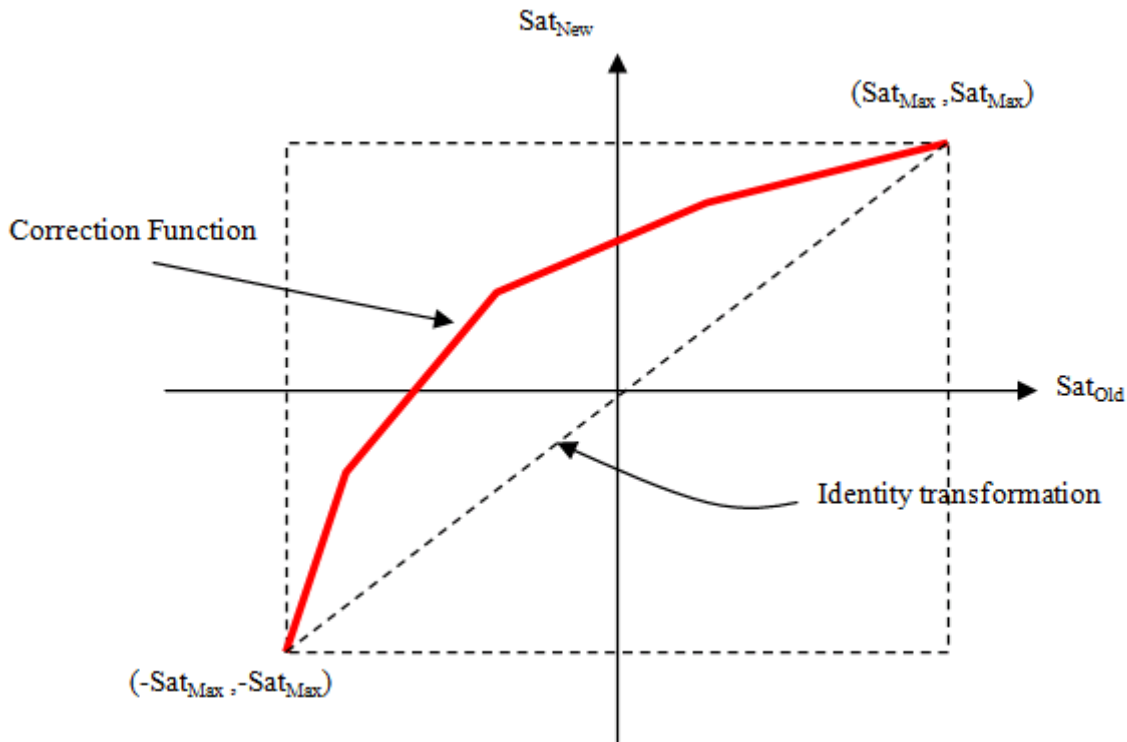

General Form of the Saturation Correction PwLF

Note: Although the points with $Sat < -Sat_{Max}$ are processed, these points are not affected by the skin tone saturation correction enhancement, because for these points, the $SkinToneFactor = 0$.

Hue Correction Enhancement

The hue correction enhancement is performed by the transformation $Hue_{New} = F_{SHue}(Hue_{Old})$, which is realized by the piece-wise linear function F_{Hue} with 4 linear segments.

The parameters of this PwLF are:

- Points:
 $HUEP_0 = -Hue_{Max}$
 $HUEP_x$ ($x=1,2,3$) – defined by the user
 $HUEP_4 = Hue_{Max}$
- Biases:
 $HUEB_0 = -Hue_{Max}$
 $HUEB_x$ ($x=1,2,3$) – defined by the user
 $HUEB_4 = Hue_{Max}$
- Slopes:

$HUES_x$ ($x=0,1,2,3$) – defined by the user

There are Programming Restrictions to specify the parameters

The point Hue = $-Hue_{Max}$ maps to itself: $(-Hue_{Max}) \rightarrow (-Hue_{Max})$.

The point Hue = Hue_{Max} maps to itself: $(Hue_{Max}) \rightarrow (Hue_{Max})$.

The correction function is continuous.

The correction function is non-decreasing.

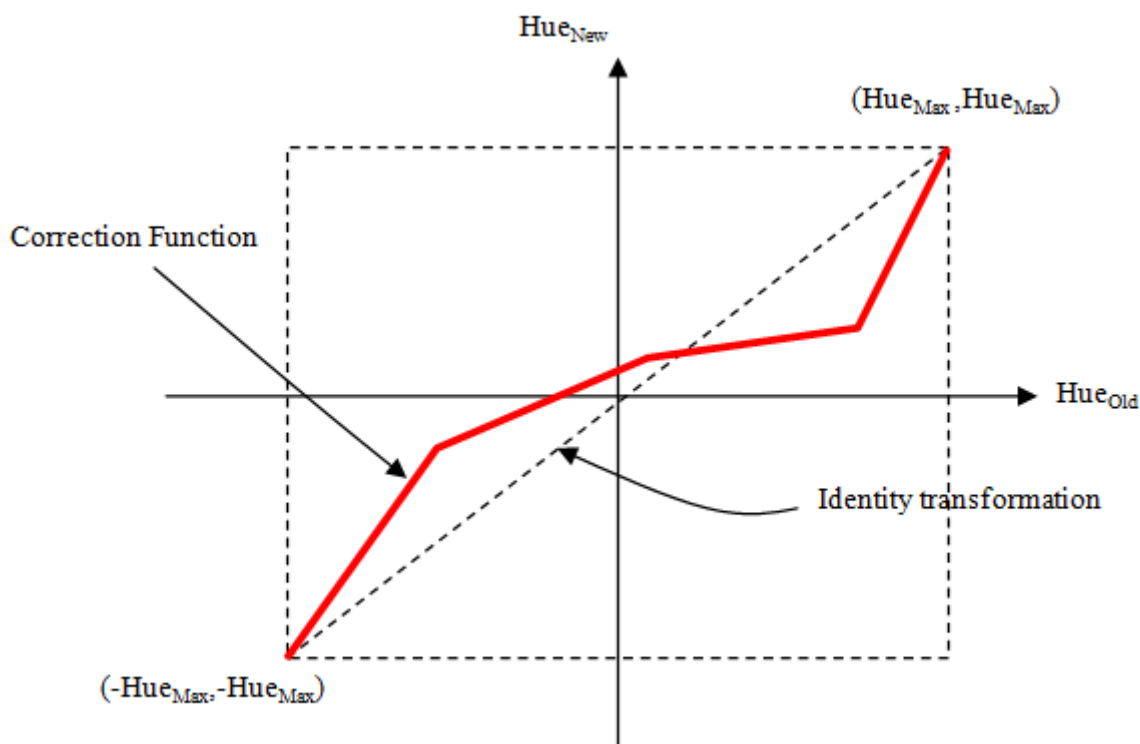

General form of the Hue Correction PWLF

Skin Type Correction Enhancement

This optional enhancement operation is enabled by setting the control parameter *Skin_Types_Enable* to 1.

In this advanced optional mode, skin tone is enhanced based on one of two skin types, Bright Skin and Dark Skin. A second set of the Saturation and Hue Correction enhancement parameters is defined, with different values in an identical structure. The second set of parameters has the suffix "_DARK" in the names.

The classification of the skin type is achieved using two parameters, *Skin_types_thesh*, and *Skin_types_margin* in the luma (Y) values.

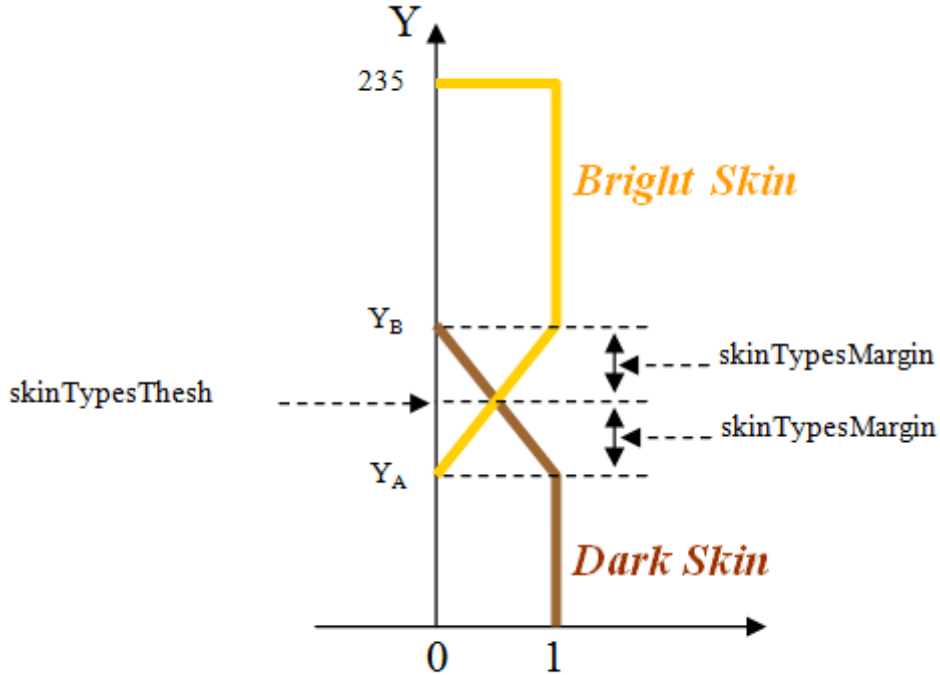

Bright/Dark Skin Type Classifier

The related parameters are:

- Points:
 - $HUEP_x_DARK$ ($x=1,2,3$) – defined by the user
 - $SATP_x_DARK$ ($x=1,2,3$) – defined by the user
- Biases:
 - $HUEB_x_DARK$ ($x=1,2,3$) – defined by the user
 - $SATB_x_DARK$ ($x=1,2,3$) – defined by the user
- Slopes:
 - $HUES_x_DARK$ ($x=0,1,2,3$) – defined by the user
 - $SATS_x_DARK$ ($x=0,1,2,3$) – defined by the user

The final values of the skin tone enhanced pixels are given by:

$$Sat_{New} = MV_{Dark} * Sat_{New D} + MV_{Bright} * Sat_{New B}$$

$$Hue_{New} = MV_{Dark} * Hue_{New D} + MV_{Bright} * Hue_{New B}$$

where MV_{Dark} and MV_{Bright} are blending factors computed from the plot above.



Transformation from (Sat, Hue) to (U, V)

The (U,V) → (Sat,Hue) transformation is processed by the two steps: *shift* and *rotation*. The inverse transformation, (Sat,Hue) → is done by: a *rotation* and then a *shift*.

The difference (DU, DV) between the skin tone enhanced and original UV values is weighted by the five-bit-per-pixel skin tone detection result *SkinToneFactor*.

The final output (U_{out},V_{out}) values are calculated by adding the weighted difference values (DU):

$$U_{out} = U_{in} + DU$$

$$V_{out} = V_{in} + DV$$

STD Score Output

This mode outputs the STD score, which is controlled by the state bit *Output STD Decisions* instead of the pixel values. In this mode, the STD should be enabled and other functions in the IECF after STDE in the pipe should be disabled. Only ACE can be enabled to collect the histogram of the STD score values.

The output when *Output STD Decision* is enabled should be as follows:

$$Y = 0x7FF + (STD_Score \ll 6)$$

$$U = 0x7FF$$

$$V = 0x7FF$$

In this mode, a histogram of skin tone distribution can be obtained in ACE module, and a special ACE PWLF curve (step function) can be configured to produce a bi-level picture to illustrate the pixels based on the level of skin tone detection.

Adaptive Contrast Enhancement (ACE)

Automatic Contrast Enhancement (ACE) is a part of the color processing pipe. It works in YCbCr444 12bpc color space.

The main goals of ACE are to improve the overall contrast of the image and to emphasize details in obscured regions, such as dark regions of the input image.

The ACE algorithm analyzes the input image and modifies contrast of the image according to its content characteristic. Analysis and contrast adjustment are performed over the Y component.

ACE algorithm generates a Piece-wise Linear Function (PWLF) that maps input luma values to output luma values. The output luma values, Y_{out}, are calculated by Y_{out} = PWLF(Y_{in}).

ACE receives skin-tone information from the Skin Tone Enhancement block. When the input image contains skin-tone colors, the effect of ACE is reduced in the regions with skin-tone colors.

ACE works on the upper 8bit MSB of Y-ch for point detection in the PWLF.



The parameter, *skin_threshold*, is used to determine if the current pixel contains skin-tone color or not.

The *Full_image_histogram* flag forces the ACE operations on all of the input pixels.

HW computes the luma histogram and the maximum and minimum luma values (Y_{max} , Y_{min}) from the input image. The number of skin-tone pixels is also computed.

The PWLF is an eleven-segment (12 points) 1D LUT and specified by the set of parameters (Points: Y_{min} , $Y1$ - $Y10$, Y_{max} , Bias: $B1$ – $B10$, Slope: $S0$ - $S10$).

Total Color Control (TCC)

TCC adjusts the color saturation level of the input image based on six anchor colors (Red, Green, Blue, Magenta, Yellow, and Cyan). The TCC algorithm operates on the UV-color components in the YUV color space on a per-pixel basis.

Input and output pixels are in the YUV444 12bpc format. The input to the TCC block is:

- U and V color components (10 bit)
- Skin-tone detection value (5 bit)
- External control parameters

The output of the TCC block is:

- Updated U and V values (10 bit)

The TCC block is implemented in HW to reduce the power of the system and improve the battery life. The throughput is two pixels per clock. See the diagram below. There are two paths in parallel to support the requirement of two pixels per clock.

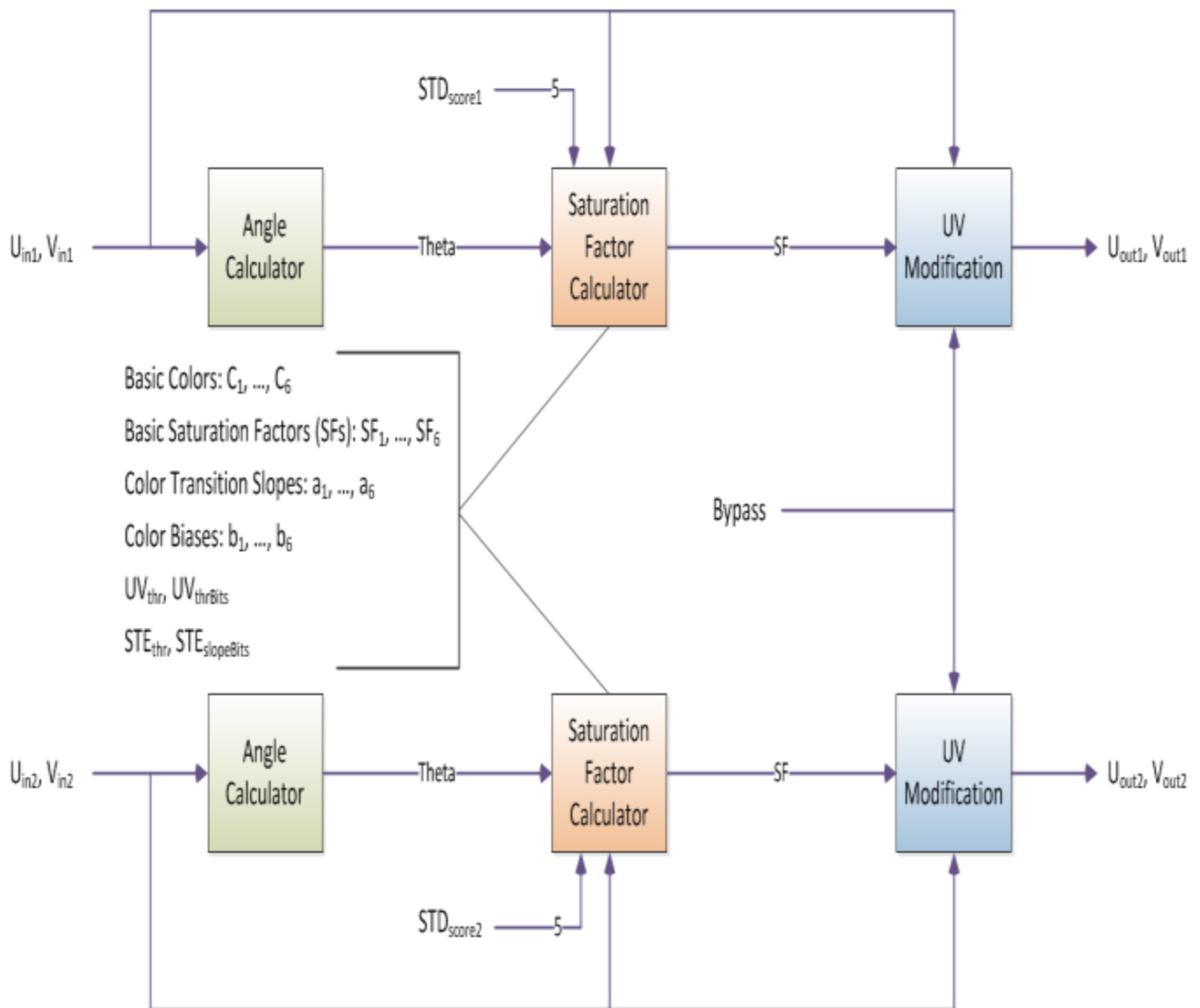

The TCC block is controlled by state only and does not require any memory access. The TCC block runs at the same frequency as the existing RCPBunit.

The TCC block includes three sub-blocks: Angle_Calculator, Saturation_Factor_Calculator, UV_Modification.

Angle_Calculator

This sub-block computes the color hue angle, θ , in radians (10 bit approximation with maximal error of 0.005 rad).

Saturation_Factor_Calculator

This sub-block uses the angle θ to find the corresponding anchor colors and calculates the multiplicative saturation factor in 8-bit per pixel.

This block requires several external input parameters such as:



- *BaseColor1, ..., BaseColor6* – Six basic user-defined colors (anchor colors)
- *SatFactor1, ..., SatFactor6* – Six user-defined saturation factors for anchor colors
- *ColorTransitSlope12, ..., ColorTransit61* – Six calculation results of $1/(\text{BaseColorX} - \text{BaseColorY})$ for anchor colors
- *ColorBias1, ..., ColorBias6* – Six color biases for anchor colors
- *STDscore* – Skin-Tone Detection score (from the STD/E block)

There are four intermediate saturation factors, SFs1, SFs2, SFs3, and SFs4. The final saturation factor SFfinal is equal to SFs4.

The first saturation factor SFs1 is computed from the external input parameters (*SatFactori, BaseColori, ColorTransitSlopei, ColorBiasi*) and the color hue angle θ .

Computation of the saturation factor SFs2 involves (*UVMaxColor, Inv_UVMaxColor*) where *UVMaxColor* is the maximum (and legal) absolute UV values, which in the case of YUV color space equals 448 in 10-bit representation. *Inv_UVMaxColor* is the inverse calculation of *UVMaxColor*, that is, $1/UVMaxColor$.

The third saturation factor SFs3 involves CLF which is Color Limiting Factor and ranges from 0 to 1. CLF is computed using a threshold value *UV_Threshold*.

The last and fourth saturation factor SFs4 considers the skin-tone pixels and a threshold value *STE_Threshold*.

UV Modification

The input UV pixels are multiplied by the saturation factor SFfinal in this sub-block.

The calculation of the modified output U_{new} and V_{new} values are:

$$\begin{aligned}U_{new} &= U * SF_{final} \\V_{new} &= V * SF_{final}\end{aligned}$$

where (U, V) are the input color components.

ProcAmp

The PROCAMP block modifies the brightness, contrast, hue, and saturation of the input image in YUV color space.

Input and output pixels are in the YCbCr 444 12bpc (bits per channel) format. Precision=12.

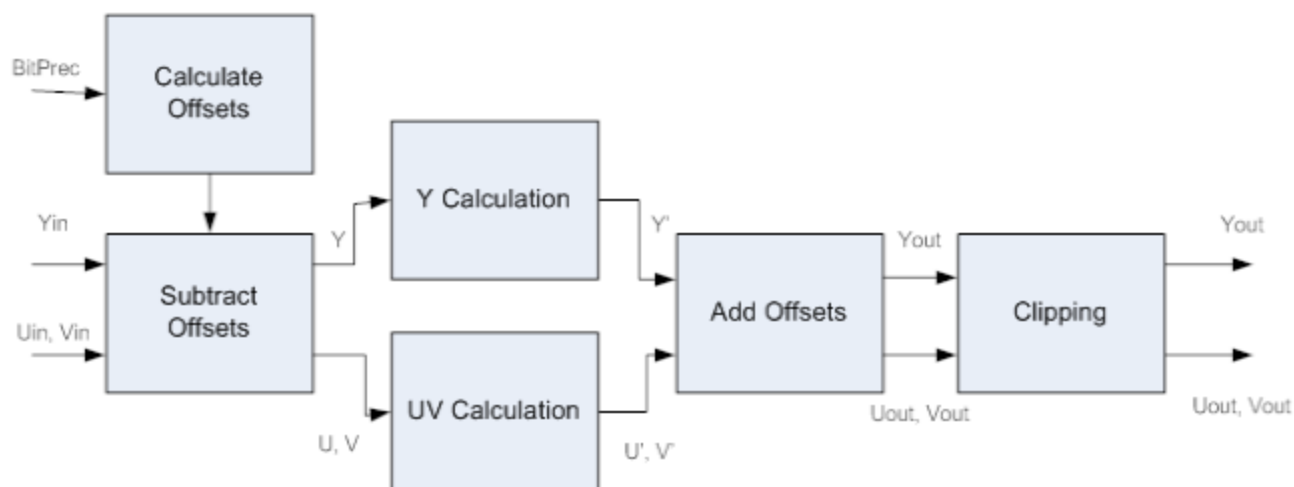

Y Processing:

An offset of 256 (that is, 16 in 8bpc) is subtracted from the 12-bit Y values to position the black level at zero. This removes the DC offset so that adjusting the contrast does not vary the black level. Since Y values may be less than 256, negative Y values should be supported at this point. Contrast is adjusted by multiplying the YUV pixel values by a constant. If U and V are adjusted, a color shift results whenever the contrast is changed. The brightness property value is added (or subtracted) from the contrast adjusted Y values; this is done to avoid introducing a DC offset due to adjusting the contrast. Finally the offset 256 is added back to reposition the black level at 256.

The equation for processing Y values is:

$$Y_{out}' = ((Y_{in} - 256) \times C) + B + 256,$$

Where C is the Contrast adjustment value and B is the Brightness adjustment value.

UV Processing:

An offset of 2048 (that is, 128 in 8bpc) is subtracted from the 12-bit U and V values. The hue adjustment is implemented by combining the U and V input values together as in:

$$\begin{aligned} U_{out}' &= (U_{in} - 2048) \times \cos(H) + (V_{in} - 2048) \times \sin(H) \\ V_{out}' &= (V_{in} - 2048) \times \cos(H) - (U_{in} - 2048) \times \sin(H) \end{aligned}$$

Where H represents the desired Hue angle; Saturation is adjusted by multiplying the U and V input values by a constant S.

Finally, the offset value 2048 is added back to both U and V.

The combined processing of Hue, Saturation, and Contrast on the UV data is:

$$\begin{aligned} U_{out}' &= (((U_{in} - 2048) \times \cos(H) + (V_{in} - 2048) \times \sin(H)) \times C \times S) + 2048 \\ V_{out}' &= (((V_{in} - 2048) \times \cos(H) - (U_{in} - 2048) \times \sin(H)) \times C \times S) + 2048 \end{aligned}$$

Where C is the contrast, H is Hue angle, and S is the Saturation.



The multiplication factors $\text{Cos}(H)x^*C_x^*S$ and $\text{Sin}(H)x^*C_x^*S$ are programmed by the parameters Cos_c_s and Sin_c_s .

Color Space Conversion

The CSC block enables linear conversion between different color spaces such as YCbCr and RGB using vector shifts and matrix multiplication.

The CSC algorithm is a linear coordinate transformation, comprising of the following steps:

1. Shift the input color coordinate
2. Multiply by 3x3 matrix
3. Shift the output color coordinate

The formula representation of the 3 steps is:

$$\begin{pmatrix} \mathbf{vout_1} \\ \mathbf{vout_2} \\ \mathbf{vout_3} \end{pmatrix} = \begin{pmatrix} \mathbf{a11} & \mathbf{a12} & \mathbf{a13} \\ \mathbf{a21} & \mathbf{a22} & \mathbf{a23} \\ \mathbf{a31} & \mathbf{a32} & \mathbf{a33} \end{pmatrix} * \begin{pmatrix} \mathbf{vin_1+v0_1} \\ \mathbf{vin_2+v0_2} \\ \mathbf{vin_3+v0_3} \end{pmatrix} + \begin{pmatrix} \mathbf{u0_1} \\ \mathbf{u0_2} \\ \mathbf{u0_3} \end{pmatrix}$$

where

- a_{ij} are the 3x3 matrix elements [$C0, C1, C2, C3, C4, C5, C6, C7, C8$] in S2.10
- vin_i are the color components of the input pixel in U12
- $vout_i$ are the color components of the output pixel in U12
- $v0_i$ are the input offset vector elements [$Offset_in_1, Offset_in_2, Offset_in_3$] in S10
- $u0_{1,i}$ are the output offset vector elements [$Offset_out_1, Offset_out_2, Offset_out_3$] in S10

The output pixel values are clipped to ensure that each color component is within the valid range.



Color Gamut Compression

Background of Color Gamut Compression

While most photography today complies with the sRGB standard color space, which covers around 72% of the color perceived by humans, this 72% content looks incorrect/unnatural on wide gamut displays, which can extend more than 100%. Therefore, a gamut mapping (GM) algorithm is required to adjust when the input gamut range is different from the output gamut range such as an input sRGB color space displayed on a wide gamut display, or to adjust wide gamut content to display on traditional lower gamut displays.

The easiest compression method applied to displaying wider gamut content on lower gamut displays is to clip the out of range primary values to the valid range (i.e., 0-1). Although this simple clipping procedure leads to acceptable visual appearance in most cases, loss of color depth can be observed in the video containing out-of-range pixels. The reason behind this effect should be the uniform quantization process applied to out-of-range values (e.g., two distinct out-of-range red colors are mapped to the same boundary red color). Moreover, the simple clipping method treats each color channel independently. This may lead to unexpected perceptual loss since the composite ratios of three primaries have been changed. An approach which takes these two factors into account while scaling down the out of range values can possibly maintain the detail information of the image.

Project:	SNB+
Input and output pixel is 444 format and 12bits per channel. Precision=12; Prec_shift = 4.	

Usage Models

There are two usage models depending on the set up of the *FullRangeMappingEnable* bit:

Basic mode: fixed-hue color gamut clipping mode

Advanced mode: fixed-hue full range mapping mode

The application of basic mode of the fixed-hue color gamut clipping is preferred when the content having the smaller percentage of out-of-range pixels in the scene. The advanced mode of fixed-hue full range mapping mode may also change the in-range pixels and is thus preferred when the percentage of out-of-range pixel is large. The outcome of the in/out range pixel percentage is derived from the out-of range color gamut detection module to provide an indicator to operate among basic mode and advanced mode.



Gamut Compression Module Overview

The main goal of color gamut compression module algorithm is to compress out-of-range pixel values while keeping their hue values same as it is before compression. A block diagram to color gamut compress the xv Color video into sRGB format is shown below.

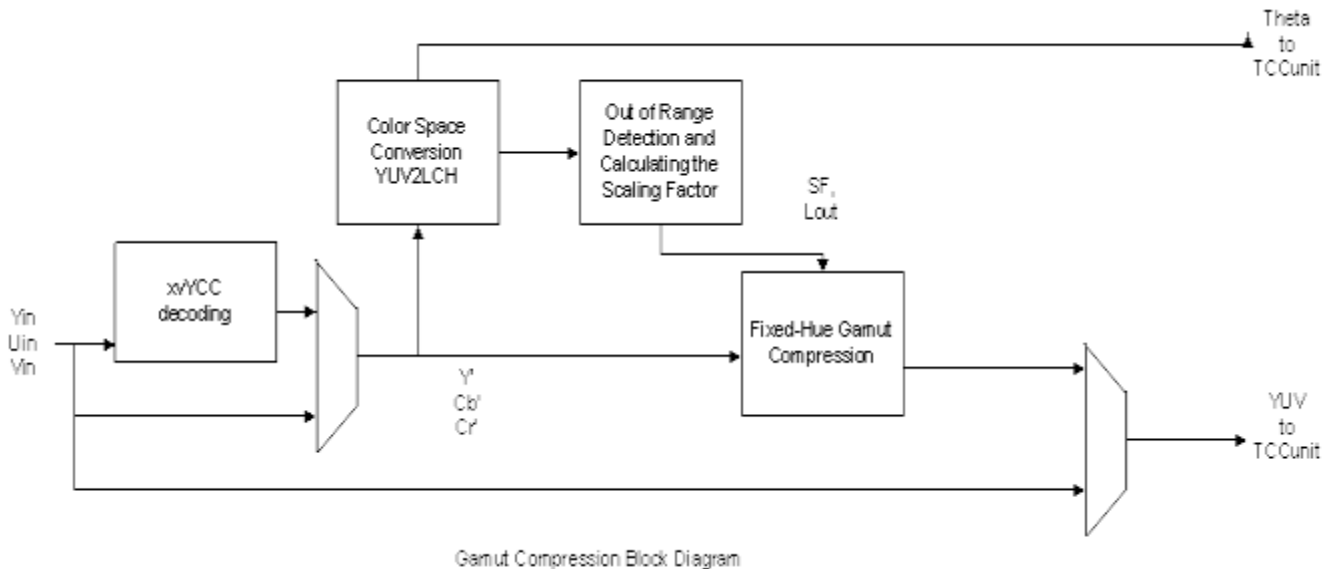

AT the pipeline level, the input into Gamut compression unit is from STDE unit and the output from the Gamut compression goes to TCCE unit. The Gamut compression comprises of the following stages:

xvYCC decoding

YUV2LCH color space conversion

Out of range Gamut pixel detection

Scaling factor calculation

Find out the Euclidean distance for the out of range pixel for advance mode

Fixed-hue Gamut compression

Bring the out of range pixel to the boundary for basic mode

Bring the out of range pixel depending on the distance and apply uniform quantization process in advance mode

xvYCC encoding

xvYCC decoding

The input non-linear YCbCr values (i.e., $Y'Cb'Cr'$, or $Y'UV$) are decoded into linear, normalized yuv space.



$$y = (Y - 16 * 2^{Src_prec-8}) / (219 * 2^{Src_prec-8})$$
$$u = (Cb - 128 * 2^{Src_prec-8}) / (224 * 2^{Src_prec-8})$$
$$v = (Cr - 128 * 2^{Src_prec-8}) / (224 * 2^{Src_prec-8})$$

Depending on the characteristics (e.g., linearity) of the input to gamut compression module, the state parameter *xvYCCDecEncEnable* can be utilized to indicate whether xvYCC decoding (later with xvYCC encoding) needs to be turned on.

Src prec is 12.

YUV2LCH

The scaling factors utilized to compress the out-of-gamut pixels are derived in Lightness-Chroma-Hue (LCH) color-space. The conversion from linear yuv space to LCH space is known as:

$$l = y$$
$$c = \sqrt{u^2 + v^2}$$
$$h = \tan^{-1}(v/u)$$

Out-of-Gamut Pixel Detection

For the mapping of xvYCC to sRGB, both gamuts share the same primaries as those defined in either BT.601 or BT. 709. With the transformation matrix available for yuv-rgb conversion in BT. 601 or BT. 709, the sRGB gamut boundary can be depicted as a rectangle for each hue plane. The rectangle which is the sRGB gamut boundary for a hue is characterized by its three vertices: (0, 0), (Cv_h, Lv_h), and (0, 1). An example of the concept of gamut boundary is given in below figure.

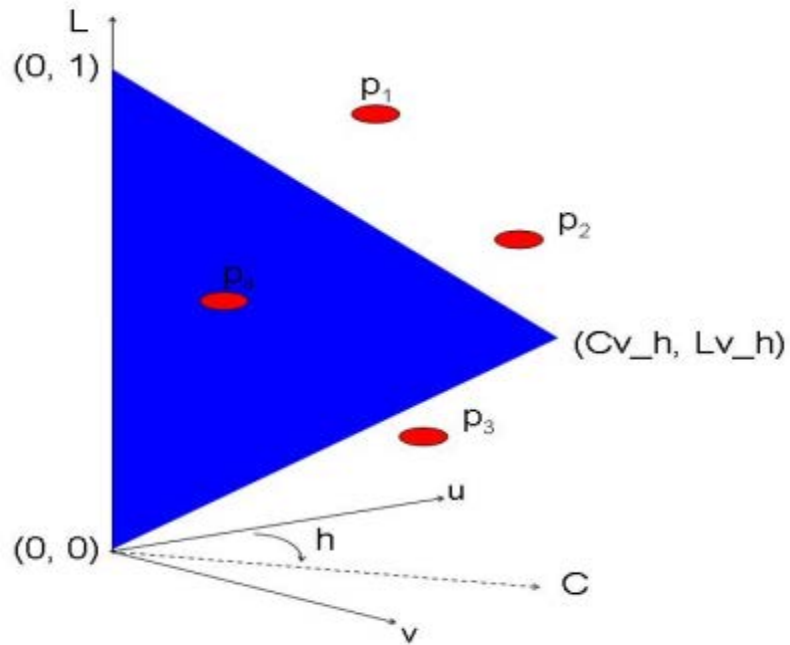

Gamut boundary: the sRGB gamut boundary is a rectangle shape for each hue plane. p1, p2, p3, p4 are pixels with the same hue value.

VEBOX_VERTEX_TABLE serves as the storage place for the programmed vertex information (Cv_h, Lv_h) where the continuous [0- π] hue plane is quantized to be 512 resulting in a 512x2-entries table with 12bpc for every entry.

With the destination gamut depicted as aggregation of rectangles over all hue planes, out-of-gamut pixel detection block works in LC-plane indexed by a pixel's hue value and determine whether the pixel falls outside the rectangle. For example, p1, p2, and p3 in the above figure would be detected as out-of-gamut pixels. A statistic parameter, **number_of_out-of-range_pixel** collects the number of out-of-gamut pixels at picture level through VSC unit. This statistic parameter may be utilized to assess the property of a picture to achieve intelligent selection of gamut compression mode applied to the input picture.

Scaling Factor – Basic Mode

The slope of a compression line is defined from the vertex point table.

$$m_{comp} = m_{vert} \gg (\text{compression_line_shift}), \text{ with } \text{compression_line_shift} \text{ default to be } 3.(5)$$

m_{comp} in the above equation is the slope of the compression line while m_{vert} represents the slope of the line perpendicular to the RGB boundary line:

$$m_{vert} = -\frac{1}{m_{boundary}}, \text{ and (6)}$$

$$m_{boundary} = \frac{(l_V - e_V)}{c_V} \text{ where } e_V = \begin{cases} 1, & \text{if } l_{p_i} > l_V \\ 0, & \text{else} \end{cases} \text{ .(7)}$$

The intersection between the compression line for pixel p_i and the L -axis is denoted as I_{p_i}

$$I_{p_i} = (c_{I_{p_i}}, l_{I_{p_i}}), \text{ then}$$

$$c_{I_{p_i}} = 0, \text{ and (8)}$$

$$l_{I_{p_i}} = l_{p_i} - c_{p_i} \times m_{comp}$$

The point nearest to the input pixel p_i on the RGB boundary along the compression direction (i.e., intersection between the compression line and the RGB boundary) be B_{p_i} , then

$$B_{p_i} = (c_{B_{p_i}}, l_{B_{p_i}}), \text{ with}$$

$$c_{B_{p_i}} = \frac{(l_{p_i} - e_V)}{(m_{boundary} - m_{comp})}, \text{ and (9)}$$

$$l_{B_{p_i}} = c_{B_{p_i}} \times m_{boundary} + e_V$$

Scaling factor is denoted as



$$sf_{p_i} = \frac{C_{p_i,output}}{C_{p_i}} \quad (10)$$

For the usage of Basic mode - fixed-hue color gamut clipping mode, all out-of-range pixels will be clipped to the boundary, which means

$$C_{p_i,output} = C_{B_{p_i}} \quad (11)$$

And the luma is mapped at along the compression line to hit the boundary line at

$$l_{p_i,output} = l_{I_{p_i}} + C_{p_i,output} \times m_{comp} \quad (12)$$

Fixed-Hue Compression

The output of fixed compression is based on the scaling factor and the property of pixel.

$$\begin{cases} u_{p_i,out} = u_{p_i,in} \\ v_{p_i,out} = v_{p_i,in} \\ y_{p_i,out} = y_{p_i,in} \end{cases}, \text{ if } C_{p_i} = 0 \text{ or } P_i \in \text{in_range_pixel}, \text{ else } \begin{cases} u_{p_i,out} = u_{p_i,in} \times sf_{p_i} \\ v_{p_i,out} = v_{p_i,in} \times sf_{p_i} \\ y_{p_i,out} = l_{p_i,output} \end{cases} \quad (13)$$

Scaling Factor – Advanced Mode

The out-of-range pixel values can be mapped inwards according to how far they are from the boundary from the following equation:

$$C_{p_i,output} = C_{R_{p_i}} + (C_{p_i} - C_{R_{p_i}}) \times \frac{d_{p_i,final}}{d(R_{p_i}, p_i)} \quad (14)$$

$$l_{p_i,output} = l_{I_{p_i}} + C_{p_i,output} \times m_{comp}$$

Where $C_{R_{p_i}}$ is coming from the reference point as the origin of the linear transformation for

compressing pixel P_i as

Denote the reference point



$$R_{p_i} = (c_{R_{p_i}}, l_{R_{p_i}})$$

$$l_{R_{p_i}} = \begin{cases} \max(l_{I_{p_i}}, l_V), & \text{if } l_{p_i} > l_V \\ \min(l_{I_{p_i}}, l_V), & \text{otherwise} \end{cases} \quad (15)$$

$$c_{R_{p_i}} = (l_{R_{p_i}} - l_{I_{p_i}}) \times \frac{1}{m_{comp}}$$



Shared Functions Pixel Interpolator

The Pixel Interpolator provides barycentric parameters at various offsets relative to the pixel location. These barycentric parameters are in the same format and layout as those received in the pixel shader dispatch. Please refer to the "Windower" chapter in the "3D Pipeline" volume for more details on barycentric parameters.

Barycentric parameters delivered in the pixel shader payload are at pre-defined positions based on **Barycentric Interpolation Mode** bits selected in 3DSTATE_WM. The pixel interpolator allows barycentric parameters to be computed at additional locations.



Messages

The following is the message definition for the Pixel Interpolator shared function.

Restriction: Pixel Interpolator messages can only be delivered by pixel shader kernels.

Execution Mask. Each bit in the execution mask enables the corresponding slot's barycentric parameter return to the destination registers.

Initiating Message

Message Descriptor

Bits	Description	Project
19	<p>Header Present: Specifies whether the message includes a header phase. Must be zero for all <i>Pixel Interpolator</i> messages.</p> <p>Format = Enable</p>	
18:1 7	Ignored	
16	<p>SIMD Mode. Specifies the SIMD mode of the message being sent.</p> <p>Format = U1</p> <p>0: SIMD8 mode 1: SIMD16 mode</p>	
15	Ignored	
14	<p>Interpolation Mode. Specifies which interpolation mode is used.</p> <p>Format = U1</p> <p>0: Perspective Interpolation 1: Linear Interpolation</p> <p>Programming Note: This field cannot be set to "Linear Interpolation" unless Non-Perspective Barycentric Enable in 3DSTATE_CLIP is enabled.</p>	
13:1 2	<p>Message Type. Specifies the type of message being sent when pixel-rate evaluation requested.</p> <p>Format = U2</p> <p>0: Per Message Offset (eval_snapped with immediate offset) 1: Sample Position Offset (eval_sindex) 2: Centroid Position Offset (eval_centroid) 3: Per Slot Offset (eval_snapped with register offset)</p>	
	Project:	



Bits	Description	Project
	<p>Note: When "eval_centroid" is selected and Render Target Independent Rasterization is selected, the rasterizer may produce incorrect results.</p>	
11	<p>Slot Group Select. This field selects whether slots 15:0 or slots 31:16 are used for bypassed data.</p> <p>Bypassed data includes the X/Y addresses and centroid position. For 8- and 16-pixel dispatches, SLOTGRP_LO must be selected on every message. For 32-pixel dispatches, this field must be set correctly for each message based on which slots are currently being processed.</p> <p>0: SLOTGRP_LO: Choose bypassed data for slots 15:0. 1: SLOTGRP_HI: Choose bypassed data for slots 31:16.</p> <p>Programming Note: This field must be set to SLOTGRP_LO for SIMD8 messages. SIMD8 messages always use bypassed data for slots 7:0.</p>	
10:8	Ignored	
7:0	<p>Message Specific Control. Refer to the sections below for the definition of these bits based on Message Type.</p>	

Per Message Offset Message Descriptor

Bit	Description
7:4	<p>Per Message Y Pixel Offset</p> <p>Specifies the Y Pixel Offset that applies to all slots.</p> <p>Format = S4 2's complement representing units of 1/16 pixel. Range = [-8/16, +7/16]</p>
3:0	<p>Per Message X Pixel Offset</p> <p>Specifies the X Pixel Offset that applies to all slots.</p> <p>Format = S4 2's complement representing units of 1/16 pixel. Range = [-8/16, +7/16]</p>

Sample Position Offset Message Descriptor

Bit	Description
7:4	<p>Sample Index</p> <p>Specifies the sample index that applies to all slots.</p>



Bit	Description
	Format = U4 Range = [0,15]
3:0	Ignored

Centroid Position and Per Slot Offset Message Descriptor

Bit	Description
7:0	Ignored

Message Payload for Most Messages

This message payload applies to the following message types:

- Per Message Offset
- Sample Position Offset
- Centroid Position Offset

DWord	Bit	Description
M0.7:0		Ignored

SIMD8 Per Slot Offset Message Payload

This message payload applies only to the SIMD8 Per Slot Offset message type. The message length is 2.

DWord	Bit	Description
M0.7	31:0	Slot 7 X Pixel Offset Specifies the X pixel offset for slot 7. Format = S4 2's complement representing units of 1/16 pixel. The upper 28 bits are ignored. Range = [-8/16, +7/16]
M0.6	31:0	Slot 6 X Pixel Offset
M0.5	31:0	Slot 5 X Pixel Offset
M0.4	31:0	Slot 4 X Pixel Offset
M0.3	31:0	Slot 3 X Pixel Offset
M0.2	31:0	Slot 2 X Pixel Offset



DWord	Bit	Description
M0.1	31:0	Slot 1 X Pixel Offset
M0.0	31:0	Slot 0 X Pixel Offset
M1.7	31:0	Slot 7 Y Pixel Offset Specifies the Y pixel offset for slot 7. Format = S4 2's complement representing units of 1/16 pixel. The upper 28 bits are ignored. Range = [-8/16, +7/16]
M1.6	31:0	Slot 6 Y Pixel Offset
M1.5	31:0	Slot 5 Y Pixel Offset
M1.4	31:0	Slot 4 Y Pixel Offset
M1.3	31:0	Slot 3 Y Pixel Offset
M1.2	31:0	Slot 2 Y Pixel Offset
M1.1	31:0	Slot 1 Y Pixel Offset
M1.0	31:0	Slot 0 Y Pixel Offset

SIMD16 Per Slot Offset Message Payload

This message payload applies only to the SIMD16 Per Slot Offset message type. The message length is 4.

DWord	Bit	Description
M0.7	31:0	Slot 7 X Pixel Offset Specifies the X pixel offset for slot 7. Format = S4 2's complement representing units of 1/16 pixel. The upper 28 bits are ignored. Range = [-8/16, +7/16]
M0.6	31:0	Slot 6 X Pixel Offset
M0.5	31:0	Slot 5 X Pixel Offset
M0.4	31:0	Slot 4 X Pixel Offset



DWord	Bit	Description
M0.3	31:0	Slot 3 X Pixel Offset
M0.2	31:0	Slot 2 X Pixel Offset
M0.1	31:0	Slot 1 X Pixel Offset
M0.0	31:0	Slot 0 X Pixel Offset
M1.7	31:0	Slot 15 X Pixel Offset
M1.6	31:0	Slot 14 X Pixel Offset
M1.5	31:0	Slot 13 X Pixel Offset
M1.4	31:0	Slot 12 X Pixel Offset
M1.3	31:0	Slot 11 X Pixel Offset
M1.2	31:0	Slot 10 X Pixel Offset
M1.1	31:0	Slot 9 X Pixel Offset
M1.0	31:0	Slot 8 X Pixel Offset
M2.7	31:0	Slot 7 Y Pixel Offset Specifies the Y pixel offset for slot 7. Format = S4 2's complement representing units of 1/16 pixel. The upper 28 bits are ignored. Range = [-8/16, +7/16]
M2.6	31:0	Slot 6 Y Pixel Offset
M2.5	31:0	Slot 5 Y Pixel Offset
M2.4	31:0	Slot 4 Y Pixel Offset
M2.3	31:0	Slot 3 Y Pixel Offset
M2.2	31:0	Slot 2 Y Pixel Offset
M2.1	31:0	Slot 1 Y Pixel Offset



DWord	Bit	Description
M2.0	31:0	Slot 0 Y Pixel Offset
M3.7	31:0	Slot 15 Y Pixel Offset
M3.6	31:0	Slot 14 Y Pixel Offset
M3.5	31:0	Slot 13 Y Pixel Offset
M3.4	31:0	Slot 12 Y Pixel Offset
M3.3	31:0	Slot 11 Y Pixel Offset
M3.2	31:0	Slot 10 Y Pixel Offset
M3.1	31:0	Slot 9 Y Pixel Offset
M3.0	31:0	Slot 8 Y Pixel Offset



Writeback Message

SIMD8

The response length for all SIMD8 messages is 2. The data for each slot is written only if its corresponding execution mask bit is set.

DWord	Bit	Description
W0.7	31:0	Barycentric[1] for Slot 7 Format = IEEE_Float
W0.6	31:0	Barycentric[1] for Slot 6
W0.5	31:0	Barycentric[1] for Slot 5
W0.4	31:0	Barycentric[1] for Slot 4
W0.3	31:0	Barycentric[1] for Slot 3
W0.2	31:0	Barycentric[1] for Slot 2
W0.1	31:0	Barycentric[1] for Slot 1
W0.0	31:0	Barycentric[1] for Slot 0
W1.7	31:0	Barycentric[2] for Slot 7 Format = IEEE_Float
W1.6	31:0	Barycentric[2] for Slot 6
W1.5	31:0	Barycentric[2] for Slot 5
W1.4	31:0	Barycentric[2] for Slot 4
W1.3	31:0	Barycentric[2] for Slot 3
W1.2	31:0	Barycentric[2] for Slot 2
W1.1	31:0	Barycentric[2] for Slot 1
W1.0	31:0	Barycentric[2] for Slot 0



SIMD16

The response length for all SIMD16 messages is 4. The data for each slot is written only if its corresponding execution mask bit is set.

DWord	Bit	Description
W0.7	31:0	Barycentric[1] for Slot 7 Format = IEEE_Float
W0.6	31:0	Barycentric[1] for Slot 6
W0.5	31:0	Barycentric[1] for Slot 5
W0.4	31:0	Barycentric[1] for Slot 4
W0.3	31:0	Barycentric[1] for Slot 3
W0.2	31:0	Barycentric[1] for Slot 2
W0.1	31:0	Barycentric[1] for Slot 1
W0.0	31:0	Barycentric[1] for Slot 0
W1.7	31:0	Barycentric[2] for Slot 7 Format = IEEE_Float
W1.6	31:0	Barycentric[2] for Slot 6
W1.5	31:0	Barycentric[2] for Slot 5
W1.4	31:0	Barycentric[2] for Slot 4
W1.3	31:0	Barycentric[2] for Slot 3
W1.2	31:0	Barycentric[2] for Slot 2
W1.1	31:0	Barycentric[2] for Slot 1
W1.0	31:0	Barycentric[2] for Slot 0 Format = IEEE_Float
W2.7	31:0	Barycentric[1] for Slot 15



DWord	Bit	Description
W2.6	31:0	Barycentric[1] for Slot 14
W2.5	31:0	Barycentric[1] for Slot 13
W2.4	31:0	Barycentric[1] for Slot 12
W2.3	31:0	Barycentric[1] for Slot 11
W2.2	31:0	Barycentric[1] for Slot 10
W2.1	31:0	Barycentric[1] for Slot 9
W2.0	31:0	Barycentric[1] for Slot 8
W3.7	31:0	Barycentric[2] for Slot 15
W3.6	31:0	Barycentric[2] for Slot 14
W3.5	31:0	Barycentric[2] for Slot 13
W3.4	31:0	Barycentric[2] for Slot 12
W3.3	31:0	Barycentric[2] for Slot 11
W3.2	31:0	Barycentric[2] for Slot 10
W3.1	31:0	Barycentric[2] for Slot 9
W3.0	31:0	Barycentric[2] for Slot 8



Shared Functions - Unified Return Buffer (URB)

The Unified Return Buffer (URB) is a general-purpose buffer used for sending data between different threads, and, in some cases, between threads and fixed-function units (or vice-versa). A thread accesses the URB by sending messages.



URB Size

An URB entry is a logical entity within the URB, referenced by an entry handle and comprised of some number of consecutive rows. A row corresponds in size to a 256-bit EU GRF register. Read/write access to the URB is generally supported on a row-granular basis.

Project	URB Size	URB Rows	URB Rows when SLM Enabled
See the Configurations volume.			



URB Access

The URB can be *written* by the following agents:

- Command Stream (CS) can write constant data into Constant URB Entries (CURBEs) as a result of processing CONSTANT_BUFFER commands.
- The Video Front End (VFE) fixed-function unit of the Media pipeline can write thread payload data in to its URB entries.
- The Vertex Fetch (VF) fixed-function unit of the 3D pipeline can write vertex data into its URB entries.
- GEN4 threads can write data into URB entries via URB_WRITE messages sent to the URB shared function.

The URB can be *read* by the following agents:

- The Thread Dispatcher (TD) is the main source of URB reads. As a part of spawning a thread, pipeline fixed-functions provide the TD with a number of URB handles, read offsets, and lengths. The TD reads the specified data from the URB and provide that data in the thread payload pre-loaded into GRF registers.
- The Geometry Shader (GS) and Clipper (CLIP) fixed-function units of the 3D pipeline can read selected parts of URB entries to extract vertex data required by the pipeline.
- The Windower (WM) FF unit reads back depth coefficients from URB entries written by the Strip/Fan unit.

Project	Note
	The CPU cannot read the URB directly.



URB State

The URB function is stateless, with all information required to perform a function being passed in the write message.

See URB Allocation (*Graphics Processing Engine*) for a discussion of how the URB is divided amongst the various fixed functions.



URB Messages

This section documents the global aspects of the URB messages. The actual data stored in URB entries differs for each fixed function – refer to *3D Pipeline* and the fixed-function chapters or details on 3D URB data formats and *Media* for media-specific URB data formats.

URB Handles: Unlike prior products where the URB handle contents was not specified for software use, URB handles are now specified as offsets into the URB partition in the L3 cache, in 512-bit units. Thus, kernels can now perform math operations on URB handles.

The **End of Thread** bit in the message descriptor may be set on URB messages only in threads dispatched by the vertex shader (VS), hull shader (HS), domain shader (DS), and geometry shader (GS). The **End of Thread** bit cannot be set on URB_READ* or URB_ATOMIC* messages.

Execution Mask. The low 8 bits of the execution mask on the send instruction determines which DWords from each write data phase are written or which DWords from each read phase are written to the destination GRF register. The execution mask is ignored on URB_ATOMIC* messages, because this is a scalar operation that is always enabled.

Out-of-Bounds Accesses. Reads to addresses outside of the URB region allocated in the L3 cache return 0. Writes to addresses outside of the URB region are dropped and do not modify any URB data.

Message Type	Header Required	Shared Local Memory Support	Stateless Support	Address Modes	Vector Width	Project
URB Read HWORD	yes	N/A	N/A	handle + URBoffset or handle + URBoffset + offset	1, 2	
URB Write HWORD	yes	N/A	N/A	handle + URBoffset or handle + URBoffset + offset	1, 2	
URB Read OWORD	yes	N/A	N/A	handle + URBoffset or handle + URBoffset + offset	1, 2	



Message Type	Header Required	Shared Local Memory Support	Stateless Support	Address Modes	Vector Width	Project
URB Write OWORD	yes	N/A	N/A	handle + URBoffset or handle + URBoffset + offset	1, 2	
URB Atomic MOV	yes	N/A	N/A	handle + URBoffset	1	
URB Atomic INC	yes	N/A	N/A	handle + URBoffset	1	
URB Atomic ADD	yes	N/A	N/A	handle + URBoffset	1	

"offset" is in the message payload, and is per-slot.

"handle" is the handle address in the message header.

"URBoffset" is the **Global Offset** field in the URB message descriptor.

Execution Mask

The Execution Mask specified in the 'send' instruction determines which DWords within each message register are read/written to the URB.

Message Descriptor

Bits	Description
19	Header Present. This bit must be 1 for all URB messages.
18:17	Ignored
16	Per Slot Offset. If clear, the slot offset fields in the header are ignored. If set the slot offset fields are added to the global offset to obtain the overall offset. Programming Note: This bit must be 0 for URB_ATOMIC_* messages.
15	Complete. For URB_WRITE*, URB_SIMD8_WRITE and URB_ATOMIC*, this bit is ignored. For URB_READ* and URB_SIMD8_READ, if set, this bit signals that the thread is finished reading from the URB entries referenced by the handles, causing the entries to be deallocated. This bit is strictly control information passed to snooping FF units. The URB shared function itself does not use this bit for any purpose.



Bits	Description				
14	<p>Swizzle Control. This field is used to specify which "swizzle" operation is to be performed on the write data. It indirectly specifies whether one or two handles are valid.</p> <p>0: URB_NOSWIZZLE. The message accesses a single URB entry (using URB Handle 0).</p> <p>1: URB_INTERLEAVED. The message accesses two URB entries. The data is interleaved such that the upper DWords (7:4) of each 256-bit unit contain data associated with URB Handle 1, and the lower DWords (3:0) contain data associated with URB Handle 0.</p>				
13:3	<p>Global Offset. This field specifies a destination offset (in 256-bit units) from the start of the URB entries, as referenced by URB Handle <i>n</i>, at which the data (if any) is written or read.</p> <p>When URB_INTERLEAVED is used, this field provides a 256-bit granular offset applied to both URB entries.</p> <p>If the Per Slot Offset bit is set, this offset is added to the per-slot offsets in the header to obtain the overall offset.</p> <p>For the URB*_OWORD messages, this offset is in 128-bit units instead of 256-bit units.</p> <p>For the URB_ATOMIC* messages, this offset is in 32-bit units instead of 256-bit units.</p> <p>Format = U11</p> <p>Range = [0, 1023] for URB*_HWORD messages.</p> <p>Range = [0, 2047] for URB*_OWORD messages.</p> <p>Range = [0, 2047] for URB_ATOMIC* messages.</p>				
2:0	<p>URB Opcode</p> <p>0: URB_WRITE_HWORD</p> <p>1: URB_WRITE_OWORD</p> <p>2: URB_READ_HWORD</p> <p>3: URB_READ_OWORD</p> <p>4: URB_ATOMIC_MOV</p> <p>5: URB_ATOMIC_INC</p> <table border="1" data-bbox="220 1556 1369 1640"> <thead> <tr> <th data-bbox="220 1556 521 1598">Project:</th> <th data-bbox="521 1556 1369 1598">URB Opcode</th> </tr> </thead> <tbody> <tr> <td data-bbox="220 1598 521 1640">HSW</td> <td data-bbox="521 1598 1369 1640">6: URB_ATOMIC_ADD</td> </tr> </tbody> </table> <p>7: Reserved</p>	Project:	URB Opcode	HSW	6: URB_ATOMIC_ADD
Project:	URB Opcode				
HSW	6: URB_ATOMIC_ADD				

URB_WRITE and URB_READ

The URB_WRITE* and URB_READ* messages share the same header definition. URB_WRITE has additional payload containing the write data, but has no writeback message. URB_READ has no payload beyond the



header (message length is always one), but always has a writeback message. URB_WRITE_SIMD4x2 has a single-phase payload with the per-slot offsets followed by the write data, and has no writeback message. URB_READ_SIMD4x2 has a single phase payload containing the per-slot offsets.

Message Header

M0.5[7:0] bits in message header are used for enabling DWs in cull test, at HDC unit by HS kernel, while writing TF data using URB write messages. Cull test is performed on outside TF and HS kernel set the appropriate DW enable, which carry the TF for different domain types. When DW is enabled and if cull test is positive, HS stage will be informed by HDC unit, to cull the HS handle early at HS stage itself.

DWord	Bits	Description	Project	Security
M0.7	31:0			
M0.6	31:0			
M0.5	31:17	Ignored		
	16	<p>High OWORD Enable</p> <p>For URB_READ_OWORD and URB_WRITE_OWORD with NOSWIZZLE indicates whether the 128 bits of the GRF register is used.</p> <p>0: 1 OWord, read into or written from the low 128 bits of the GRF register.</p> <p>1: 1 OWord, read into or written from the high 128 bits of the GRF register.</p>		
	15	<p>Vertex 1 DATA [3] / Vertex 0 DATA[7] Channel Mask</p> <p>When Swizzle Control = URB_INTERLEAVED this bit controls Vertex 1 DATA[3].</p> <p>When Swizzle Control = URB_NOSWIZZLE this bit controls Vertex 0 DATA[7].</p> <p>This bit is ANDed with the corresponding channel enable to determine the final channel enable. For the URB_READ_OWORD & URB_READ_HWORD messages, when final channel enable is 1 it indicates that Vertex 1 DATA [3] will be included in the writeback message. For the URB_WRITE_OWORD & URB_WRITE_HWORD messages, when final channel enable is 1 it indicates that Vertex 1 DATA [3] will be written to the surface.</p> <p>0: Vertex 1 DATA [3] / Vertex 0 DATA[7] channel not included.</p>		



DWord	Bits	Description	Project	Security
		1: Vertex DATA [3] / Vertex 0 DATA[7] channel included.		
	14	Vertex 1 DATA [2] Channel Mask		
	13	Vertex 1 DATA [1] Channel Mask		
	12	Vertex 1 DATA [0] Channel Mask		
	11	Vertex 0 DATA [3] Channel Mask		
	10	Vertex 0 DATA [2] Channel Mask		
	9	Vertex 0 DATA [1] Channel Mask		
	8	Vertex 0 DATA [0] Channel Mask		
	7:0	Reserved		
M0.4	31:0	<p>Slot 1 Offset. This field, after adding to the Global Offset field in the message descriptor, specifies the offset (in 256-bit units) from the start of the URB entry, as referenced by URB Handle 1, at which the data will be accessed. This field is ignored unless Swizzle Control is set to URB_INTERLEAVED.</p> <p>For the URB_*_OWORD messages, this offset is in 128-bit units instead of 256-bit units.</p> <p>Format = U32</p> <p>Range = [0, 1023] for URB_*_HWORD messages. The range of the calculated offset must fall within the range [0, 1023] or behavior is undefined.</p> <p>Range = [0, 2047] for URB_*_OWORD messages. The range of the calculated offset must fall within the range [0, 2047] or behavior is undefined.</p>		
M0.3	31:0	<p>Slot 0 Offset. This field, after adding to the Global Offset field in the message descriptor, specifies the offset (in 256-bit units) from the start of the URB entry, as referenced by URB Handle 0, at which the data will be accessed.</p> <p>For the URB_*_OWORD messages, this offset is in 128-bit units instead of 256-bit units.</p> <p>Format = U32</p> <p>Range = [0, 1023] for URB_*_HWORD messages. The range of the calculated offset must fall within the range [0, 1023]</p>		



DWord	Bits	Description	Project	Security
		<p>or behavior is undefined.</p> <p>Range = [0, 2047] for URB*_OWORD messages. The range of the calculated offset must fall within the range [0, 2047] or behavior is undefined.</p>		
M0.2	31:16	<p>GS Number of Output Vertices for Slot 1. Indicates the number of vertices output for geometry shader slot 1 primitive. This field is only defined if end-of-thread is set on the message. It is ignored for all messages from non-GS threads.</p> <p>Format = U16</p>		
	15:0	<p>GS Number of Output Vertices for Slot 0. Indicates the number of vertices output for geometry shader slot 0 primitive. This field is only defined if end-of-thread is set on the message. It is ignored for all messages from non-GS threads.</p> <p>Format = U16</p>		
M0.1	31:16	<p>Handle ID 1. This ID is assigned by the fixed function unit and links the work in channel 1 to a specific entry within the fixed function unit. This field is ignored unless Swizzle Control indicates Interleave mode.</p>		
	15:0	<p>URB Handle 1. This is the URB handle where channel 1's results are to be written or read. This field is ignored unless Swizzle Control indicates interleave mode.</p>		
M0.0	31:16	<p>Handle ID 0. This ID is assigned by the fixed function unit and links the work in channel 0 to a specific entry within the fixed function unit. This field is ignored unless Swizzle Control indicates Interleave mode.</p>		
	15:0	<p>URB Handle 0. This is the URB handle where channel 0's results are to be written or read.</p>		

URB_WRITE_HWORD Write Data Payload

For the URB_WRITE_HWORD messages, the message payload will be written to the URB entries indicated by the URB return handles in the message header.

Payload	Usage
---------	-------



Payload	Usage
URB_NOSWIZZLE	The message payload contains data to be written to a single URB entry (e.g., one Vertex URB entry). The Swizzle Control field of the message descriptor must be set to 'NoSwizzle'.
URB_INTERLEAVED	The message payload contains data to be written to two separate URB entries. The payload data is provided in a high/low interleaved fashion. The Swizzle Control field of the message descriptor must be set to 'Interleave'.

URB_NOSWIZZLE

URB_NOSWIZZLE is used to simply write data into consecutive URB locations (no data swizzling applied).

Programming Notes:

- The URB function *will use* (not ignore) the Channel Enables associated with this message.

When URB_NOSWIZZLE is used to write vertex data, the following table shows an example layout of a URB_NOSWIZZLE payload containing one (non-interleaved) vertex containing n pairs of 4-DWord vertex elements (where for the example, n is >2).

DWord	Bit	Description
M1.7	31:0	Vertex Data [7]
M1.6	31:0	Vertex Data [6]
M1.5	31:0	Vertex Data [5]
M1.4	31:0	Vertex Data [4]
M1.3	31:0	Vertex Data [3]
M1.2	31:0	Vertex Data [2]
M1.1	31:0	Vertex Data [1]
M1.0	31:0	Vertex Data [0]
M2.7	31:0	Vertex Data [15]
M2.6	31:0	Vertex Data [14]
M2.5	31:0	Vertex Data [13]
M2.4	31:0	Vertex Data [12]
M2.3	31:0	Vertex Data [11]
M2.2	31:0	Vertex Data [10]
M2.1	31:0	Vertex Data [9]
M2.0	31:0	Vertex Data [8]
...		...
Mn.7	31:0	Vertex Data [8(n-1)+7]
Mn.6	31:0	Vertex Data [8(n-1)+6]



DWord	Bit	Description
Mn.5	31:0	Vertex Data [8(n-1)+5]
Mn.4	31:0	Vertex Data [8(n-1)+4]
Mn.3	31:0	Vertex Data [8(n-1)+3]
Mn.2	31:0	Vertex Data [8(n-1)+2]
Mn.1	31:0	Vertex Data [8(n-1)+1]
Mn.0	31:0	Vertex Data [8(n-1)+0]

URB_INTERLEAVED

The following table shows an example layout of a URB_INTERLEAVED payload containing two interleaved vertices, each containing n 4-DWord vertex elements ($n > 1$).

Programming Restrictions:

- The URB function *will use* (not ignore) the Channel Enables associated with this message.
- Writes to overlapping addresses of vertex0 and vertex1 will have undefined write ordering.

DWord	Bit	Description
M1.7	31:0	Vertex 1 Data [3]
M1.6	31:0	Vertex 1 Data [2]
M1.5	31:0	Vertex 1 Data [1]
M1.4	31:0	Vertex 1 Data [0]
M1.3	31:0	Vertex 0 Data [3]
M1.2	31:0	Vertex 0 Data [2]
M1.1	31:0	Vertex 0 Data [1]
M1.0	31:0	Vertex 0 Data [0]
M2.7	31:0	Vertex 1 Data [7]
M2.6	31:0	Vertex 1 Data [6]
M2.5	31:0	Vertex 1 Data [5]
M2.4	31:0	Vertex 1 Data [4]
M2.3	31:0	Vertex 0 Data [7]
M2.2	31:0	Vertex 0 Data [6]
M2.1	31:0	Vertex 0 Data [5]
M2.0	31:0	Vertex 0 Data [4]
...		...
Mn.7	31:0	Vertex 1 Data [4(n-1)+3]
Mn.6	31:0	Vertex 1 Data [4(n-1)+2]
Mn.5	31:0	Vertex 1 Data [4(n-1)+1]
Mn.4	31:0	Vertex 1 Data [4(n-1)+0]



DWord	Bit	Description
Mn.3	31:0	Vertex 0 Data [4(n-1)+3]
Mn.2	31:0	Vertex 0 Data [4(n-1)+2]
Mn.1	31:0	Vertex 0 Data [4(n-1)+1]
Mn.0	31:0	Vertex 0 Data [4(n-1)+0]

URB_READ_HWORD Writeback Message

For the URB_READ_HWORD messages, the URB entries indicated by the URB handles in the message header are read and returned in the writeback message. The amount of read data returned is determined by the **Response Length** field.

While GS threads will read one vertex at a time to the URB, the VS will read two interleaved vertices. The description of the URB read messages will refer to the per-vertex DWords described in the Vertex URB Entry Formats section of the *3D Overview* chapter.

Payload	Usage
URB_NOSWIZZLE	The writeback message contains data read from a single URB entry (e.g., one Vertex URB entry). The Swizzle Control field of the message descriptor must be set to 'NoSwizzle'.
URB_INTERLEAVED	The writeback message contains data read from two separate URB entries. The data is provided in a high/low interleaved fashion. The Swizzle Control field of the message descriptor must be set to 'Interleave'.

URB_NOSWIZZLE

URB_NOSWIZZLE is used to simply read data into consecutive URB locations (no data interleaving applied).

When URB_NOSWIZZLE is used to read vertex data, the following table shows an example layout of a URB_NOSWIZZLE writeback message containing one (non-interleaved) vertex containing n pairs of 4-DWord vertex elements (where for the example, n is >2).

DWord	Bit	Description
W0.7	31:0	Vertex Data [7]
W0.6	31:0	Vertex Data [6]
W0.5	31:0	Vertex Data [5]
W0.4	31:0	Vertex Data [4]
W0.3	31:0	Vertex Data [3]
W0.2	31:0	Vertex Data [2]
W0.1	31:0	Vertex Data [1]
W0.0	31:0	Vertex Data [0]
W1.7	31:0	Vertex Data [15]



DWord	Bit	Description
W1.6	31:0	Vertex Data [14]
W1.5	31:0	Vertex Data [13]
W1.4	31:0	Vertex Data [12]
W1.3	31:0	Vertex Data [11]
W1.2	31:0	Vertex Data [10]
W1.1	31:0	Vertex Data [9]
W1.0	31:0	Vertex Data [8]
...		...
Wn.7	31:0	Vertex Data [8n+7]
Wn.6	31:0	Vertex Data [8n+6]
Wn.5	31:0	Vertex Data [8n+5]
Wn.4	31:0	Vertex Data [8n+4]
Wn.3	31:0	Vertex Data [8n+3]
Wn.2	31:0	Vertex Data [8n+2]
Wn.1	31:0	Vertex Data [8n+1]
Wn.0	31:0	Vertex Data [8n+0]

URB_INTERLEAVED

The following table shows an example layout of a URB_INTERLEAVED payload containing two interleaved vertices, each containing n 4-DWord vertex elements ($n > 1$).

DWord	Bit	Description
W0.7	31:0	Vertex 1 Data [3]
W0.6	31:0	Vertex 1 Data [2]
W0.5	31:0	Vertex 1 Data [1]
W0.4	31:0	Vertex 1 Data [0]
W0.3	31:0	Vertex 0 Data [3]
W0.2	31:0	Vertex 0 Data [2]
W0.1	31:0	Vertex 0 Data [1]
W0.0	31:0	Vertex 0 Data [0]
W1.7	31:0	Vertex 1 Data [7]
W1.6	31:0	Vertex 1 Data [6]
W1.5	31:0	Vertex 1 Data [5]
W1.4	31:0	Vertex 1 Data [4]
W1.3	31:0	Vertex 0 Data [7]
W1.2	31:0	Vertex 0 Data [6]
W1.1	31:0	Vertex 0 Data [5]



DWord	Bit	Description
W1.0	31:0	Vertex 0 Data [4]
...		...
Wn.7	31:0	Vertex 1 Data [4n+3]
Wn.6	31:0	Vertex 1 Data [4n+2]
Wn.5	31:0	Vertex 1 Data [4n+1]
Wn.4	31:0	Vertex 1 Data [4n+0]
Wn.3	31:0	Vertex 0 Data [4n+3]
Wn.2	31:0	Vertex 0 Data [4n+2]
Wn.1	31:0	Vertex 0 Data [4n+1]
Wn.0	31:0	Vertex 0 Data [4n+0]

URB_WRITE_OWORD Write Data Payload

For the URB_WRITE_OWORD messages, the message payload will be written to the URB entries indicated by the URB return handles in the message header.

Payload	Usage
URB_NOSWIZZLE	The message payload contains data to be written to a single URB entry (e.g., one Vertex URB entry). The Swizzle Control field of the message descriptor must be set to 'NoSwizzle'.
URB_INTERLEAVED	The message payload contains data to be written to two separate URB entries. The payload data is provided in a high/low interleaved fashion. The Swizzle Control field of the message descriptor must be set to 'Interleave'.

URB_NOSWIZZLE

URB_NOSWIZZLE is used to simply write data into a single 128-bit URB location (no data swizzling applied).

Programming Notes:

- The URB function *will use* (not ignore) the Channel Enables associated with this message.

When URB_NOSWIZZLE is used to write vertex data, the following table shows an example layout of a URB_NOSWIZZLE payload containing one (non-interleaved) vertex containing 4-DWord vertex elements and HIGH OWORD ENABLE is 0.

DWord	Bit	Description
M1.7	31:0	Ignored
M1.6	31:0	Ignored
M1.5	31:0	Ignored
M1.4	31:0	Ignored



DWord	Bit	Description
M1.3	31:0	Vertex 0 Data [3]
M1.2	31:0	Vertex 0 Data [2]
M1.1	31:0	Vertex 0 Data [1]
M1.0	31:0	Vertex 0 Data [0]

When URB_NOSWIZZLE is used to write vertex data, the following table shows an example layout of a URB_NOSWIZZLE payload containing one (non-interleaved) vertex containing 4-DWord vertex elements and HIGH OWORD ENABLE is 1.

DWord	Bit	Description
M1.7	31:0	Vertex 0 Data [3]
M1.6	31:0	Vertex 0 Data [2]
M1.5	31:0	Vertex 0 Data [1]
M1.4	31:0	Vertex 0 Data [0]
M1.3	31:0	Ignored
M1.2	31:0	Ignored
M1.1	31:0	Ignored
M1.0	31:0	Ignored

URB_INTERLEAVED

The following table shows an example layout of a URB_INTERLEAVED payload containing two interleaved vertices, each containing 4-DWord vertex elements.

Programming Restrictions:

- The URB function *will use* (not ignore) the Channel Enables associated with this message.
- Writes to overlapping addresses of vertex0 and vertex1 will have undefined write ordering.

DWord	Bit	Description
M1.7	31:0	Vertex 1 Data [3]
M1.6	31:0	Vertex 1 Data [2]
M1.5	31:0	Vertex 1 Data [1]
M1.4	31:0	Vertex 1 Data [0]
M1.3	31:0	Vertex 0 Data [3]
M1.2	31:0	Vertex 0 Data [2]
M1.1	31:0	Vertex 0 Data [1]
M1.0	31:0	Vertex 0 Data [0]



URB_READ_OWORD Writeback Message

For the URB_READ_HWORD messages, the URB entries indicated by the URB handles in the message header are read and returned in the writeback message. The amount of read data returned is determined by the **Response Length** field.

Programming Restrictions:

- **Response Length** must be set to 1.

While GS threads will read one vertex at a time to the URB, the VS will read two interleaved vertices. The description of the URB read messages will refer to the per-vertex DWords described in the Vertex URB Entry Formats section of the *3D Overview* chapter.

Payload	Usage
URB_NOSWIZZLE	The writeback message contains data read from a single URB entry (e.g., one Vertex URB entry). The Swizzle Control field of the message descriptor must be set to 'NoSwizzle'.
URB_INTERLEAVED	The writeback message contains data read from two separate URB entries. The data is provided in a high/low interleaved fashion. The Swizzle Control field of the message descriptor must be set to 'Interleave'.

URB_NOSWIZZLE

URB_NOSWIZZLE is used to simply read data into consecutive URB locations (no data interleaving applied).

When URB_NOSWIZZLE is used to read vertex data, the following table shows an example layout of a URB_NOSWIZZLE writeback message containing one (non-interleaved) vertex containing 4-DWord vertex elements and HIGH OWORD ENABLE is 0.

DWord	Bit	Description
W0.7	31:0	Reserved (not written to GRF)
W0.6	31:0	Reserved (not written to GRF)
W0.5	31:0	Reserved (not written to GRF)
W0.4	31:0	Reserved (not written to GRF)
W0.3	31:0	Vertex Data [3]
W0.2	31:0	Vertex Data [2]
W0.1	31:0	Vertex Data [1]
W0.0	31:0	Vertex Data [0]

When URB_NOSWIZZLE is used to read vertex data, the following table shows an example layout of a URB_NOSWIZZLE writeback message containing one (non-interleaved) vertex containing 4-DWord vertex elements and HIGH OWORD ENABLE is 1.

DWord	Bit	Description
-------	-----	-------------



DWord	Bit	Description
W0.7	31:0	Vertex Data [3]
W0.6	31:0	Vertex Data [2]
W0.5	31:0	Vertex Data [1]
W0.4	31:0	Vertex Data [0]
W0.3	31:0	Reserved (not written to GRF)
W0.2	31:0	Reserved (not written to GRF)
W0.1	31:0	Reserved (not written to GRF)
W0.0	31:0	Reserved (not written to GRF)

URB_INTERLEAVED

The following table shows an example layout of a URB_INTERLEAVED payload containing two interleaved vertices, each containing 4-DWord vertex elements.

DWord	Bit	Description
W0.7	31:0	Vertex 1 Data [3]
W0.6	31:0	Vertex 1 Data [2]
W0.5	31:0	Vertex 1 Data [1]
W0.4	31:0	Vertex 1 Data [0]
W0.3	31:0	Vertex 0 Data [3]
W0.2	31:0	Vertex 0 Data [2]
W0.1	31:0	Vertex 0 Data [1]
W0.0	31:0	Vertex 0 Data [0]

URB_ATOMIC

The URB_ATOMIC messages implement atomic operations on a single DWord in the URB. The location of the DWord within the URB is specified by the single URB handle and the **Global Offset** field in the message descriptor, which for these messages is a DWord offset from the URB handle. The DWord selected is operated on according to the following table:

URB Opcode	new_dst	ret	Project
URB_ATOMIC_MOV	0	none	
URB_ATOMIC_INC	old_dst + 1	old_dst	
URB_ATOMIC_ADD	old_dst + src0	old_dst	

The previous contents of the DWord are returned in the destination register for operations that update the DWord value, such as URB_ATOMIC_INC. The URB_ATOMIC_MOV opcode does not return data (response length must be zero).

The URB_ATOMIC* messages consist only of the header. A single URB handle is specified.



Message Header

DWord	Bits	Description	Security
M0.7	31:0		
M0.6	31:0		
M0.5	31:0	Ignored	
M0.4	31:0	Ignored	
M0.3	31:0	Ignored	
M0.2	31:0	Source0 Data Specifies the source 0 data for the atomic operation. This field is ignored for the URB_ATOMIC_INC message. Format = U32	
M0.1	31:0	Ignored	
M0.0	31:16	Ignored	
	15:0	URB Handle. The URB handle to access.	

Writeback Message

A writeback message is only returned for URB atomic operations that update the DWord value, such as URB_ATOMIC_INC. Only the low 32 bits of the destination GRF register are overwritten with the return data.

DWord	Bits	Description
W0.7:1		Reserved (not written to GRF)
W0.0	31:0	Return Data Specifies the value of the return data for the atomic operation. Format = U32



Message Gateway

The Message Gateway shared function provides a mechanism for active thread-to-thread communication. Such thread-to-thread communication is based on direct register access. One thread, a *requester thread*, is capable of writing into the GRF register space of another thread, a *recipient thread*. Such direct register access between two threads in a multi-processor environment some time is referred to as *remote register access*. Remote register access may include read or write. The architecture supports *remote register write*, but not remote register read (natively). Message Gateway facilitates such remote register write via message passing. The requester thread sends a message to Message Gateway requesting a write to the recipient thread's GRF register space. Message Gateway sends a writeback message to the recipient thread to complete the register write on behalf of the requester. The requester thread and the recipient thread may be on the same EU or on different EUs.

When Bypass Gateway Control is set to 1, the commands OpenGateway and CloseGateway are no longer used, the gateway parameters are taking the default values as the following:

- **RegBase** = 0
- **Gateway Size** check and **Key** check are bypassed.
- **Gateway Open** (an internal signal that is used to be set by OpenGateway message) check is bypassed

A separate Gateway exists per half-slice in the architecture. For ForwardMsg this is handled transparently, but barriers can only be accessed by threads in the local half-slice. This means that all threads that access a shared barrier need to use the half-slice select in GPGPU_OBJECT and MEDIA_OBJECT to stay on a single half-slice. GPGPU_WALKER handles this automatically.



Messages

Message Gateway supports such thread-to-thread communication with the following messages:

- **OpenGateway:** Opens a gateway for a requester thread. Once a thread successfully opens its gateway, it can be a recipient thread to receive remote register write.
- **CloseGateway:** Closes the gateway for a requester thread. Once a thread successfully closes its gateway, Message Gateway blocks any future remote register writes to this thread.
- **ForwardMsg:** Forwards a formatted message (remote register write) from a requester thread to a recipient thread.
- **GetTimeStamp:** Reads absolute and relative timestamps for a requester thread.
- **BarrierMsg:** A set of threads sends this message to the Gateway. When all threads in a group have sent the message, a reply (both a register write and an N0 notification) is sent to each member of the group.
- **UpdateGatewayState:** Updates the internal state of the Message Gateway.

One example usage is to allow a control thread to change Barrier Byte to convey dynamic state information. This may be used to support interrupt when persistent compute/worker threads are synchronized using Barrier.

Project:
<ul style="list-style-type: none"> • MMIO Read/Write: allows a message to read or write an MMIO register. The MEDIA_VFE_STATE command has a field which limits the accesses for security.

Message Descriptor

The following message descriptor applies to all messages supported by Message Gateway.

Bits	Description
19	Header Present. This bit must be 0 for all Message Gateway messages.
18:17	Ignored.
16:15	<p>Notify. Send Notification Signal. This is a two-bit field indicating which notify event is sent.</p> <p>00b: No notify.</p> <p>01b: Increment recipient thread's N0 notification counter.</p> <p>10b: Increment recipient thread's N2 notification counter.</p> <p>11b: Reserved.</p> <p>This field is only valid for a ForwardMsg message. It is ignored for other messages. The BarrierMsg message always increments the N0 notification counter.</p>
14	AckReq. Acknowledgment Required. When this bit is set, an acknowledgment return message is required. Message Gateway sends a writeback message containing the error code to the requester thread using the



Bits	Description
	<p>post destination register address. When this bit is 0, no writeback message is sent to the requesting thread by Message Gateway, even if an error occurs.</p> <p>This field is valid for OpenGateway, CloseGateway, ForwardMsg, and BarrierMsg messages.</p> <p>When this bit is 1, post destination register must be valid and the response length must be 1.</p> <p>When this bit is 0, post destination register must be <i>null</i> and the response length must be 0.</p> <p>This bit cannot be set when EOT is set; otherwise, hardware behavior is undefined.</p> <p>0: No Acknowledgement is required.</p> <p>1: Acknowledgement is required.</p>
13:3	Reserved: MBZ
2:0	<p>SubFuncID. Identify the supported sub-functions by Message Gateway. Encodings are:</p> <p>000b: OpenGateway. Open the gateway for the requester thread.</p> <p>001b: CloseGateway. Close the gateway for the requester thread.</p> <p>010b: ForwardMsg. Forward the formatted message to the recipient thread with the given offset from the recipient's register base.</p> <p>011b: GetTimeStamp. Read absolute and relative timestamps.</p> <p>100b: BarrierMsg. Record an additional thread reaching the barrier.</p> <p>101b: UpdateGatewayState. Update the barrier byte for a barrier.</p> <p>110b: MMIO Read/Write.</p> <p>111b: Reserved.</p>

OpenGateway Message

The OpenGateway message opens a communication channel between the requesting thread and other threads. It specifies a key for other threads to access its gateway, as well as the GRF register range allowed to be written. The message consists of a single 256-bit message payload.

If the AckReq bit is set, a single 256-bit payload writeback message is sent back to the requesting thread after completion of the OpenGateway function. Only the least significant DWord in the post destination register is overwritten.

If the EOT is set for this message, Message Gateway ignores this message; instead, it closes the gateway for the requesting thread regardless of the previous state of the gateway.

It is software's policy to determine how to generate the key.

Project:	
The BarrierMsg command does not use an OpenGateway message.	



Message Payload

DWord	Bits	Description	Security
M0.5	31:29	Reserved: MBZ	
	28:21	<p>RegBase: The register base address to be stored in the Message Gateway. It is used to compute the destination GRF register address from the offset field in ForwardMsg. RegBase contains 256-bit GRF aligned register address.</p> <p>Note 1: This field aligns with bits [28:21] of the Offset field of the message payload for ForwardMsg.</p> <p>Note 2: The most significant bit of this field must be zero.</p> <p>Format = U8</p> <p>Range = [0,127]</p>	
	20:11	Reserved: MBZ	
	10:8	<p>Gateway Size: The range limit for messages through the Message Gateway.</p> <p>000b: 1 GRF Register</p> <p>001b: 2 GRF Registers</p> <p>010b: 4 GRF Registers</p> <p>011b: 8 GRF Registers</p> <p>100b: 16 GRF Registers</p> <p>101b: 32 GRF Registers</p> <p>110b: 64 GRF Registers</p> <p>111b: 128 GRF Registers</p>	
	7:0	<p>Dispatch ID: This ID is assigned by the fixed function unit and is a unique identifier for the thread. It is used to free up resources used by the thread upon thread completion.</p> <p>This field is ignored by Message Gateway.</p> <p>This field is only required for a thread that is created by a fixed function (therefore, not a child thread) and EOT bit is set for the message.</p>	
M0.4	31:16	Reserved: MBZ	
	15:0	Reserved: MBZ.	
M0.3:0	31:0	Ignored	

Writeback Message to Requester Thread

The writeback message is only sent if the **AckReq** bit in the message descriptor is set.



DWord	Bits	Description
W0.7:1	31:0	Reserved (not overwritten)
W0.0	31:20	Reserved
	19:16	Shared Function ID. The message gateway's shared function ID.
	15:3	Reserved
	2:0	Error Code 000b: Successful. No Error (Normal). 101b: Opcode Error. Attempt to send a message which is not either open/close/forward. Other codes: Reserved.

CloseGateway Message

The CloseGateway message closes a communication channel for the requesting thread that was previously opened with OpenGateway. Each thread is allowed to have only one open gateway at a time, thus no additional information in the message payload is required to close the gateway. The message consists of a single 256-bit message payload.

If the AckReq bit is set, a single 256-bit payload writeback message is sent back to the requesting thread after completing the CloseGateway function. Only the least significant DWord in the post destination register is overwritten.

Project:
The BarrierMsg command does not use a CloseGateway message.

Message Payload

DWord	Bit	Description
M0.7:6		Ignored
M0.5	31:8	Ignored
	7:0	Dispatch ID: This ID is assigned by the fixed function unit and is a unique identifier for the thread. It is used to free up resources used by the thread upon thread completion. This field is ignored by Message Gateway This field is only required for a thread that is created by a fixed function (therefore, not a child thread) and EOT bit is set for the message.
M0.4:0		Ignored

Writeback Message to Requester Thread

The writeback message is only sent if the **AckReq** bit in the message descriptor is set.



DWord	Bit	Description
W0.7:1		Reserved (not overwritten)
W0.0	31:20	Reserved
	19:16	Shared Function ID: Contains the message gateway's shared function ID.
	15:3	Reserved
	2:0	Error Code 000: <i>Successful</i> . No Error (Normal) 101: <i>Opcode Error</i> . Attempt to send a message which is not either open/close/forward other codes: Reserved

ForwardMsg Message

The ForwardMsg message gives the ability for a requester thread to write a **data segment** in the form of a byte, a dword, 2 dwords, or 4 dwords to a GRF register in a recipient thread. The message consists of a single 256-bit message payload, which contains the specially formatted data segment.

The ForwardMsg message utilizes a communication channel previously opened by the recipient thread. The recipient thread has communicated its EUID, TID, and key to the requester thread previously via some other mechanism. Generally, this is done through the thread spawn message from parent to child thread, allowing each child (requester) to then communicate with its parent through a gateway opened by the parent (recipient). The child could then use ForwardMsg message to communicate its own EUID, TID, and key back to the parent to enable bi-directional communication after opening its own gateway.

If the AckReq bit is set, a single 256-bit payload writeback message is sent back to the requester thread after completion of the ForwardMsg function. Only the least significant DWord in the post destination register is overwritten.

If the Notify bit in the message descriptor is set, a *notification* is sent to the recipient thread in order to increment the recipient thread's notification counter. This allows multiple messages to be sent to the recipient without waking up the recipient thread. The last message, having this bit set, will then wake up the recipient thread.

Message Payload

DWord	Bit	Description
M0.7	31:0	
M0.6	31:0	
M0.5	31:29	Reserved: MBZ
	28:16	Offset: It provides the destination register position in the recipient thread GRF register space as the offset from the RegBase stored in the recipient thread's gateway entry. The offset is in unit of byte, such that bits [28:21] is the 256-bit aligned register offset and bits [4:0] is the sub-register offset.



DWord	Bit	Description
		<p>The sub-register offset must be aligned to the Length field in bits [10:8]. The subfields of Offset are further illustrated as the following.</p> <p>Offset[28:21]: Register offset from the gateway base (Range [0, 127]: bit 12 MBZ)</p> <p>Offset[20:18]: DW offset</p> <p>Offset[17:16]: Byte offset (must be 00 for all DW length cases)</p> <p>Programming restriction: R0 can not be used as destination GRF register for ForwardMsg. NULL register is also not allowed as destination.</p>
	15:11	Reserved: MBZ
	10:8	<p>Length: The length of the data segment.</p> <p>000: 1 byte</p> <p>001: 1 word</p> <p>010: 1 dword</p> <p>011: 2 dwords</p> <p>100: 4 dwords</p> <p>101-111: Reserved</p>
	7:0	<p>Dispatch ID: This ID is assigned by the fixed function unit and is a unique identifier for the thread. It is used to free up resources used by the thread upon thread completion.</p> <p>This field is ignored by Message Gateway</p> <p>This field is only required for a thread that is created by a fixed function (therefore, not a child thread) and EOT bit is set for the message.</p>
M0.4	31:30	Ignored
	29	SliceID: The Slice ID as part of the Recipient field is used to identify the slice containing the EU to whom the message is forwarded.
	28	HalfSliceID: The Half-slice ID is used to identify the half-slice containing the EU to whom the message is forwarded. For project before HSW the half-slice ID is encoded in the EUID.
	31:30	
	29:28	
	27:24	EUID: The Execution Unit ID as part of the Recipient field is used to identify the recipient thread to whom the message is forwarded.
	23:19	Ignored
	18:16	TID: The Thread ID as part of the Recipient field is used to identify the recipient thread to whom the message is forwarded.



DWord	Bit	Description	
	15:0	Key The key to match with the one stored in the recipient thread's entry in Message Gateway. [DevSNB+] Ignored	
M0.3	31:0	Data Segment DWord 3: valid only for the 4-DWord data segment length	
M0.2	31:0	Data Segment DWord 2: valid only for the 4-DWord data segment length	
M0.1	31:0	Data Segment Dword 1: valid only for the 2- and 4-DWord data segment lengths	
M0.0	31:24	Data Segment Byte 0: the same byte must be copied to all four positions within this DWord. Valid only for the 1-Byte data segment length.	Data Segment Dword 0: valid only for the 1-, 2- and 4-Dword data segment lengths
	23:16	Data Segment Byte 0	
	15:8	Data Segment Byte 0	
	7:0	Data Segment Byte 0	

Writeback Message to Requester Thread

The writeback message is only sent if the **AckReq** bit in the message descriptor is set.

DWord	Bits	Description
W0.7:1	31:0	Reserved (not overwritten)
W0.0	31:20	Reserved
	19:16	Shared Function ID. The message gateway's shared function ID.
	15:3	Reserved
	2:0	Error Code 000b: Successful. No Error (Normal). 001b: Reserved. 010b: Gateway Closed. Attempt to send a message through a closed gateway. 011b: Reserved. 100b: Reserved. 101b: Opcode Error. Attempt to send a message which is not either open/close/forward. 110b: Invalid Message Size. Attempt to forward a message with length greater than 4 DWords.



DWord	Bits	Description
		111b: Reserved.

Writeback Message to Recipient Thread

This message contains the byte or dwords data segment indicated in the message written to the GRF register offset indicated. Only the byte/dword(s) will be enabled, all other data in the GRF register is untouched.

GetTimeStamp Message

The GetTimeStamp message gives the ability for a requester thread to read the timestamps back from the message gateway. The message consists of a single 256-bit message payload.

AbsoluteTimeLap is based on an absolute wall clock in unit of nSec/uSec that is independent of context switch or GPU frequency adjustment. Message Gateway shares the same GPU timestamp. Details can be found in the TIMESTAMP register section in *vol1c Memory Interface and Command Stream*.

RelativeTimeLap is based on a relative time count that is counting the GPU clocks for the context. The relative time count is saved/restored during context switch.

Message Payload

DWord	Bit	Description
M0.7	31:0	
M0.6	31:0	
M0.5	31	Return to High GRF: 0: the return 128-bit data goes to the first half of the destination GRF register 1: the return 128-bit data goes to the second half of the destination GRF register
	30:8	Reserved : MBZ
	7:0	Dispatch ID: This ID is assigned by the fixed function unit and is a unique identifier for the thread. It is used to free up resources used by the thread upon thread completion. This field is ignored by Message Gateway This field is only required for a thread that is created by a fixed function (therefore, not a child thread) and EOT bit is set for the message.
M0.4	31:0	Ignored
M0.3	31:0	Ignored
M0.2	31:0	Ignored
M0.1	31:0	Ignored
M0.0	31:0	Ignored



Writeback Message to Requester Thread

As the writeback message is only sent if the **AckReq** bit in the message descriptor is set, **AckReq** bit must be set for this message.

Only half of the destination GRF register is updated (via write-enables). The other half of the register is not changed. This is determined by the **Return to High GRF** control field.

Writeback Message if Return to High GRF is set to 0:

DWord	Bit	Description
W0.7:4		Reserved (not overwritten)
W0.3	31:0	RelativeTimeLapHigh: This field returns the MSBs of time lap for the relative clock since the previous reset. This field represents 1.024 uSec increment of the time stamp. Hardware handles the wraparound (over 64 bit boundary) of the timestamp. Format: U12
W0.2	31:20	RelativeTimeLapLow: This field returns the LSBs of time lap for the relative clock since the previous reset. This field represents 1/4 nSec increment of the time stamp. Hardware handles the wraparound (over 64 bit boundary) of the timestamp. Format: U12
	19:0	Reserved : MBZ
W0.1	31:0	AbsoluteTimeLapHigh: This field returns the MSBs of time lap for the absolute clock since the previous reset. This field represents 1.024 uSec increment of the time stamp. Hardware handles the wraparound (over 64 bit boundary) of the timestamp. Format: U12
W0.0	31:20	AbsoluteTimeLapLow: This field returns the LSBs of time lap for the absolute clock since the previous reset. This field represents 1/4 nSec increment of the time stamp. Hardware handles the wraparound (over 64 bit boundary) of the timestamp. Format: U12
	19:0	Reserved : MBZ

Writeback Message if Return to High GRF is set to 1:

DWord	Bit	Description
W0.7	31:0	RelativeTimeLapHigh
W0.6	31:20	RelativeTimeLapLow
	19:0	Reserved : MBZ
W0.5	31:0	AbsoluteTimeLapHigh



DWord	Bit	Description
W0.4	31:20	AbsoluteTimeLapLow
	19:0	Reserved : MBZ
W0.3:0		Reserved : MBZ

BarrierMsg Message

The BarrierMsg message gives the ability for multiple threads to synchronize their progress. This is useful when there are data shared between threads. The message consists of a single 256-bit message payload.

Upon receiving one such message, Message Gateway increments the Barrier counter and mark the Barrier requester thread. There is no immediate response from the Message Gateway. When the counter value equates **Barrier Thread Count**, Message Gateway will send response back to all the Barrier requesters.

Message Payload

DWord	Bit	Description
M0.7	31:0	
M0.6	31:0	
M0.5	31:0	Ignored
M0.4	31:0	Ignored
M0.3	31:0	Ignored
M0.2	31	Ignored
	30	Ignored
	30:28	Ignored
	27:24	BarrierID . This field indicates which one from the 16 Barrier States is updated. Format: U4 Note: this field location matches with that of R0 header.
	23:16	Ignored
	15	Barrier Count Enable : Allows the message to reprogram the barrier count. If set, the current value of the barrier state is compared to the Barrier Count field (below). If these values are equal, the barrier is considered satisfied, barrier responses are sent to the waiting thread(s) including the sending thread, and the barrier state is reset to 0. If these values are not equal, the



DWord	Bit	Description
		<p>barrier state is incremented and the sending thread is added to the list of threads waiting on this barrier.</p> <p>If clear, the Message Gateway increments the Barrier counter and marks the Barrier requester thread. There is no immediate response from the Gateway. When the counter value equates Barrier Thread Count, Gateway will send response back to all the Barrier requesters.</p> <p>Format: Enable</p>
	14:9	<p>Barrier Count:</p> <p>If Barrier Count Enable is set, this field specifies the terminating barrier count. Otherwise this field is ignored. All threads that belong to a single barrier must deliver the same value for this field for a particular barrier iteration.</p>
	8:0	Ignored
M0.1	31:0	Ignored
M0.0	31:4	Ignored

Writeback Message to Requester Thread

The writeback message is only sent if the **AckReq** bit in the message descriptor is set.

DWord	Bits	Description
W0.7:1		Reserved (not overwritten)
W0.0	31:20	Reserved
	19:16	Shared Function ID. Contains the message gateway's shared function ID.
	15:3	Reserved
	2:0	<p>Error Code</p> <p>000: <i>Successful.</i> No Error (Normal).</p> <p>001: <i>Error (Barrier is inactive).</i></p> <p>Other encodings are reserved.</p>

Broadcast Writeback Message

When the count for a Barrier reaches Barrier.Count, the Message Gateway sends the notification bit N0 to each EU/Thread that reached the barrier. A Barrier Return Byte is not sent.

DWord	Bit	Description
W0.7:1	31:0	Reserved (not overwritten)



DWord	Bit	Description
W0.0	31:16	Reserved (not overwritten)
	15:8	Reserved (not overwritten)
	7:0	Reserved (not overwritten)

MMIOReadWrite Message

MMIO read/write is not allowed to registers that are associated with a particular slice.

Description	Project	Security
-------------	---------	----------

Message Payload

DWord	Bit	Description
M0.7	31:0	
M0.6	31:0	
M0.5	31:0	Ignored
M0.4	31:0	Ignored
M0.3	31:1	Ignored
	0	MMIO R/W: 0 – MMIO Read – a response will be sent to the EU with read data 1 – MMIO Write – no response is sent to EU (unless acknowledge requested in sideband)
M0.2	31:28	Ignored
	22:0	MMIO Address: The MMIO Byte address to be accessed. The bottom 2 bits must be zero.
M0.1	31:0	Ignored
M0.0	31:0	MMIO Write Data (Only if MMIO R/W = 1, otherwise ignored).

Writeback Message to Requester Thread (MMIO Read Only)

DWord	Bit	Description
R0.7	31:0	Ignored
R0.6	31:0	Ignored
R0.5	31:0	Ignored
R0.4	31:0	Ignored
R0.3	31:0	Ignored
R0.2	31:0	Ignored



DWord	Bit	Description
R0.1	31:0	Ignored
R0.0	31:0	MMIO Read Data



Shared Functions - Media Sampler

This section describes the functionality of the Media Sampler.



Video Motion Estimation

The Video Motion Estimation (VME) engine is a shared function that provides motion estimation services. It includes motion estimation for various block sizes and also standard specific operations such as

- Motion estimation and mode decision for AVC
- Intra prediction and mode decision for AVC
- Motion estimation and mode decision for MPEG2
- Motion estimation and mode decision for VC1

The motion estimation engine may also be used for other coding standards or other video processing applications.

Theory of Operation

VME performs a sequence of operations to find the best mode for a given macroblock. Each operation step can be enabled/disabled through the control of the income message. Early termination, skipping of subsequent operation steps, is also supported when certain search criteria are met.

VME contains the following operation steps:

1. Skip check
2. IME: Integer motion estimation
3. FME: Fractional motion estimation
4. BME: Bidirectional motion estimation
5. IPE: Intra prediction estimation (AVC only)

Shape Decision

As a terminology, we call sub-block shapes: 8x4, 4x8, and 4x4 *minor shapes* (corresponding to *sub-partitions* of 8x8 sub-macroblock), and 16x16, 16x8, 8x16, and 8x8 *major shapes* (corresponding to *sub-macroblocks* of a 16x16 macroblock).

If the maximal allowed number of motion vectors **MaxNumMVs** (**MaxNumMVs** = **MaxNumMVsMinusOne** + 1) is less than 4, we will set minor MV flag off: **MinorMVsFlag** = 0, *i.e.* no minor motion vectors will be generated.

The reason of having this parameter **MaxNumMVs** is due to high level AVC conformance restrictions for certain profiles: *the total number of motion vectors of any two consecutive macroblocks not exceeding 16 (or 32)*. The mechanism here allows a reasonable degree of user control. In disable cases, **MaxNumMVs** should be set to 32.

In the coding process of VME, the shape decision is done in multiple locations:

- 1) After IME and before FME, intermediate shape decision is performed to reduce the FME searching candidates



2) After FME and before BME, existing shape decision is revised among the remaining candidates and to see if there is further reduction.

3) Final shape decision is done after BME.

Partition decision before BME uses unidirectional motion vector count to meet **MaxNumMVs** requirement. Adding BME for the partition candidates may exceed **MaxNumMVs**. As BME is performed on a block by block basis using the block order for a given partition, BME step for a given block is skipped and the best unidirectional motion vectors are used for the block if the overall motion vector count exceeds **MaxNumMVs** when that particular block is switched to bidirectional. The process continues to the last block of the partition.

Note: This is a sub-optimal solution to simplify the hardware implementation. For some cases, bidirectional modes with larger sub-partitions might be better than unidirectional modes with finer sub-partitions.

The VME implementation has the following restriction: Multiple partition candidates are only enabled if **PartCandidateEn** is set. And this only applies to source block of size 16x16.

If **PartCandidateEn** is not set, only the best partition is kept in state 1 (after IME) above and carried through FME and BME. In other words, FME if enabled only operates on one partition candidate, and BME if enabled only operates on one partition candidate. Bidirectional mode check only applies to the partition candidates that meet the bidirectional restriction provided by **BiSubMbPartMask**. For example, if a minor partition determined based on best unidirectional cost function is not 8x8 but one of 4x8, 8x4 or 4x4, VME skips the bidirectional mode check.

If **PartCandidateEn** is set, up to two sets of candidates are maintained by VME hardware, if the second best partition candidate is within **PartToleranceThrh** from the best one. The second best partition is selected only from the two major partition candidates based on the unidirectional motion vector count, subject to that the major partition is enabled:

- 1MV: The 16x16 partition
- 4MV: The 4x(8x8) partition with no minor shape

The following partitions are not supported as alternative partition.

- 2MV: The best of 2x(16x8) and 2x(8x16) partitions
- More than 4MV: The best of all 4x(8x8) partitions with at least one 8x8 having minor shape of 8x4, 4x8 or 4x4

Minor Shape Decision Prior to FME

If any minor shapes are selected, we decide the best minor first.

For each 8x8 sub-block, before performing bidirectional, we reduce code candidates to no more than three based on the best unidirectional motion search results (best of the forward and backward):

0) One MV, i.e. the best in shape of 8x8.

1) Up to two MVs, i.e. the best in shapes 8x8, 8x4, or 4x8. And



2) Up to four MVs, i.e. the best for the sub-block 8x8.

Now for the first and the second sub-blocks, we can merge them into up to six candidates of 2, 3, 4, 5, 6, and 8 possible motion vectors.

Do the same to the third and the fourth sub-blocks; we have similarly up to six candidates.

Now we further combine these two groups, and find the best solution under the constraint of not exceeding the number of motion vectors more than **MaxNumMVs** (see pseudo-code below for detail).

Consequently, we have the best combined 8x8 solutions with **N** motion vectors for some **N** less or equal to **MaxNumMVs**.

Assume $distA[k][s]$ is the cost-adjusted distortion of the best forward or backward motion vector mix of the k -th 8x8 sub-block of the sub-shape s , where $s=0, 1, 2,$ and 3 represent shape partitioning 8x8, 8x4, 4x8, and 4x4 respectively. Assume $distA[k][s]$ is the bidirectional one of the corresponding sub-block and sub-shape. And assume some large number, say $128 \times 16 = 2048$ is assigned to the variable, if there were no valid corresponding codes. Hence, the following pseudo-code explains the code selection algorithm.

Let's first explain the case where **MaxNumMVs** is disabled, i.e. **MaxNumMVs** ≥ 16 :

```
void SelectBestCombinedMinors(
    short *distA,
    short *MinorShape,
    short *MinorDisto)
{
    short s[4], d[4];
    s = ShapeList;
    d = DistoList;
    for ( int k=0; k<4; k++ ) {
        s[k] = 0;
        d[k] = distA[k][0];
        if ( distA[k][1]<d[k] ) { d[k] = distA[k][1]; s[k] = 1; }
        if ( distA[k][2]<d[k] ) { d[k] = distA[k][2]; s[k] = 2; }
        if ( distA[k][3]<d[k] ) { d[k] = distA[k][3]; s[k] = 3; }
    }
    * MinorDisto = d[0] + d[1] + d[2] + d[3];
    * MinorShape = s[0] | (s[1]<<2) | (s[2]<<4) | ({s[3]<<6});
}
```

Now for the case of using **MaxNumMVs** control:

```
void SelectBestCombinedMinors(
    short *distA,
    int    MaxNumMVs,
    short *MinorShape,
    short *MinorDisto)
{
    int k, n;
    short dist, best0 = 0, best1 = 0;
    if ( MaxNumMVs < 4 ) { // We reset other parameters.
        switch ( MaxNumMVs ) {
            case 0:
                DoIntraInter &= (~DO_INTER); // Not do Inter
                break;

            case 1:
```



```
        ShapeMask |= (NO_16X8 | NO_8X16);
        BidirMask |= NO_16X16;
        break;

    case 2:
    case 3:
        ShapeMask |= (NO_8X8 | NO_8X4 | NO_4X8 | NO_4X4);
        BidirMask |= (NO_16X8 | NO_8X16);
        break;
    }
}
if ( MaxNumMVs >= 16 ) { // It should use unrestricted code selection.
    SelectBestCombinedMinors(DistA,MinorShape,MinorDisto);
    return;
}
short *s, ShapeList[18];
short *d, DistoList[18];
s = ShapeList;
d = DistoList;
for ( k=0; k<4; k++ ){
    s[0] = 0; // 1 mv
    d[0] = distA[k][0];
    s[4] = (distA[k][2] < distA[k][1]) + 1; // 2 mvs
    d[4] = distA[k][s[1]];
    s[8] = 3; // 4 mvs
    d[8] = distA[k][3];
    s ++, d ++;
}
// Merge two:
s = ShapeList;
d = DistoList;
for ( k=0; k<2; k++ ) {
    s[16] = 0x33; // 8 mvs
    d[16] = d[8] + d[10];

    s[12] = (d[4] + d[10] < d[6] + d[8]) ? (s[4] | 0x30) : (0x03 | (s[6] << 4)); // 6
mvs    d[12] = (d[4] + d[10] < d[6] + d[8]) ? (d[4] + d[10]) < (d[6] + d[8]);

    s[10] = (d[0] + d[10] < d[8] + d[2]) ? 0x30 : 0x03; // 5 mvs
    d[10] = (d[0] + d[10] < d[8] + d[2]) ? (d[0] + d[10]) < (d[8] + d[2]);

    s[8] = s[4] | (s[6] << 4); // 4 mvs
    d[8] = d[4] + d[6];

    s[6] = (d[4] + d[2] < d[0] + d[6]) ? s[4] : (s[6] << 4); // 3 mvs
    d[6] = (d[4] + d[2] < d[0] + d[6]) ? (d[4] + d[2]) < (d[0] + d[6]);

    s[4] = 0; // 2 mvs
    d[4] = d[0] + d[2];

    if ( d[ 6] > d[ 4] ) d[ 6] = d[ 4];
    if ( d[ 8] > d[ 6] ) d[ 8] = d[ 6];
    if ( d[10] > d[ 8] ) d[10] = d[ 8];
    if ( d[12] > d[10] ) d[12] = d[10];
    d[14] = d[12];
    if ( d[16] > d[12] ) d[16] = d[12];

    s ++; d ++;
}
s = ShapeList;
```



```
d = DistoList;
* MinorDisto = 2048;
for ( k=0; k<8; k++ ) {
    n = MaxNumMVs - k;
    if ( (n>=2 && n<=8) <2 ) {
        dist = d[(k << 1) + 1] + d[n << 1];
        if ( dist < *MinorDisto ) {
            *MinorDisto = dist;
            best0 = (n << 1);
            best1 = (k << 1) + 1;
        }
    }
}
while ( best0 > 1 && d[best0] == d[best0-2] ) best0 -= 2;
while ( best1 > 1 && d[best1] == d[best1-2] ) best1 -= 2;
*MinorShape = s[best0] | (s[best1] << 2);
}
```

Major Shape Decision Prior to FME

Now considering the best of each 8x8 is done, and we have the total cost-adjusted-distortion for this sub-block level partition. Now among the four choices: the resulting 8x8 sub-partitioning, one 16x16, two 16x8, and two 8x16, the one gives the best cost-adjusted-distortion, will determine the final decision of partitioning shape. Any among these four, if its cost-adjusted-distortion is within *the intermediate tolerance* (which is a predefined system state) from the best distortion will be marked as **candidate shapes**.

Notice that, when the intermediate tolerance is set to 0, only the best shape will be selected as the candidate. When the intermediate tolerance is large, all four shapes will become candidates.

Assume we have all the distortions for majors enumerated in `DistoMajor[k]`, where $k = 0, 1, 2, 3, 4,$ and 5 , for 16x16, 16x8, 8x16, the combined minors, 16x8 field, and 8x8 field respectively. Assume `BestDisto` is equal to the minimal of the six values `DistoMajor[k]`, for $k = 0, \dots, 5$. Assume the intermediate tolerance is `IntTol`, the major shape k is a candidate shape if and only if $\text{DistoMajor}[k] \leq \text{BestDisto} + \text{IntTol}$.

Shape Update after FME

Among all the candidate shapes, we recheck the distortion, if any of them is no longer within the intermediate tolerance **DistortionTolerance** from the best choice; we drop it for reduced calculation.

Final Code Decision after BME

For any given candidate shape, for each motion vector, if we do have improved distortion by switch from the single direction to bi-direction, then we do it, unless the increased number of motion vectors hits above **MaxNumMVs**; in this case, we take as many as possible first the ones generate the most improvement.

Then, we choose the best among the improved candidate shapes.



Integer Motion Estimation

IME, the integer motion estimation, is the most key part of VME. In our current design, the minimal functional block is to do a full search over a search unit. This functional block is then called via two distinctive methods:

1. Via a predefined searching path of search units.
2. Via a dynamic process based on the previous results.

This section will describe both.

Reference Window and Search Units

The reference window is a rectangular region fetched put in the reference cache for VME. Either one or two reference windows are allowed to be loaded into the reference cache. In the case of dual windows, both windows follow a common search path or different paths (relative to their corresponding Start Center) depending on the dual search path option flag.

The total reference cache is limited to 2K bytes and only the luma component searching is performed. For example, we may select the reference windows to be one of the following sample choices: one 64x32 area, one 48x40 area, two 40x24 areas, or two 32x32 areas, where the possible reference address will cover an area of 48x16, 32x24, 24x8, and 16x16.

As a convention, we will call the valid reference addressing region the *reference region*, and its width and height are called the *reference window width* and *height* respectively. So the reference loading region of VME has therefore 16 more columns and 16 more rows.

It is not efficient for hardware to search one location at a time due to reference cache access bandwidth and latency constraints. Thus, possible reference search locations are grouped in a predefined pattern, and all locations within the same group must be either all are chosen or all are skipped. These predefined groups are called *search unit* (SU). *Reference Window and Search Units* shows a sample of grouping search locations into searching units. The reference window in the figure has a dimension of 32x20, and assuming the source block is 8x8, the dark dots indicate all legitimate reference locations for motion searching. It shows a partitioning of SUs of 16 locations.

In general, the indices of SUs are given by counting rows and units within the row.

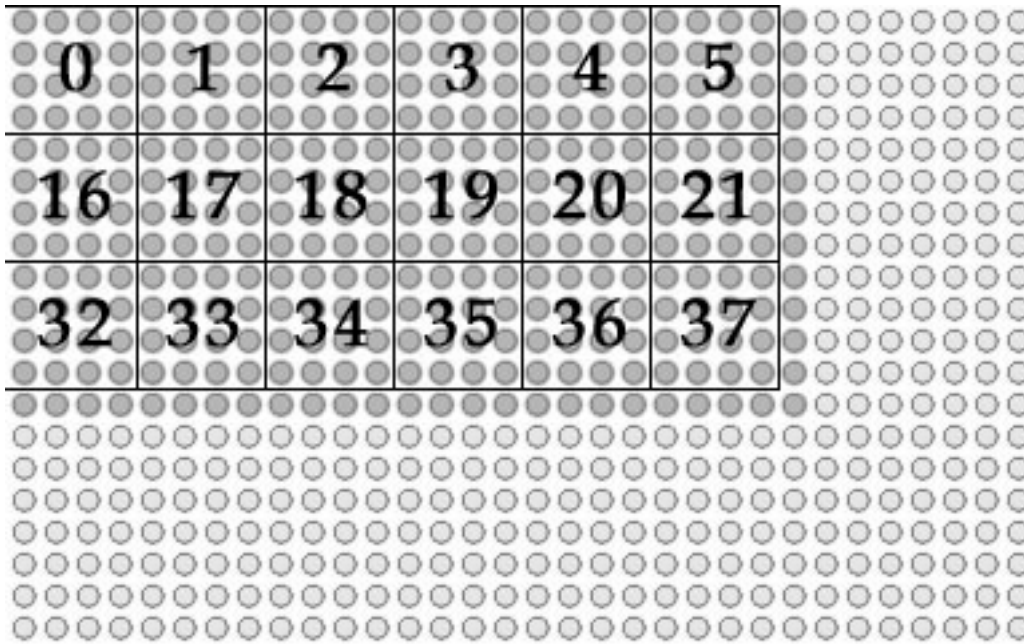

Example of Search Units in a reference window

Given a fixed reference cache access latency, SU size is determined solely based on the source block size as shown in *Reference Window and Search Units*. Note that SU sizes for both 16x8 and 8x16 source blocks are both 8x4, which gives a preference for motions along horizontal direction.

Determination of Search Unit size based on Source Block dimension

Source Block Dimension	Search Unit (SU) Size (X x Y)	GT Support
16x16	4x4	Y
16x8	8x4	Y
8x16	8x4	N
8x8	8x8	Y

To keep tracking on whether a SU has been searched or not, an equivalent hardware process is implemented performing as a *search record* that marks whether any search units being searched is a bit-plan of the bit-length equal to the maximal index of SUs. Before searching starts, the search record must be reset which sets the value 0 (= yet-to-be-searched) to all legitimate SU indices, and the value 1 (= no longer available) for other SUs that are not intended to be searched.

Given a search window, unique indices are assigned to all SUs. A search path (SP), is a sequence of such indices. The number of SUs in a SP is called the length of the walker (denoted by Len_{SP} here), which shall be a number more than one. Instead of storing the absolute indices of a search path, relative *search unit deltas* are sent instead. In the current VME a search unit delta is a 8 bit index consisting of a pair of 4-bit signed integers in $[-8,8)$.



Given start center in a pair of 4-bit unsigned integer (sx, sy) , and denote a search path described in SU deltas $(dx[i], dy[i])$. The first search unit SU[0] will be the search unit which has the first reference address $(sx*4, sy*4)$ in integer-pel relative to the reference origin., i.e.

$SU[0].x = sx*4$, and $SU[0].y = sy*4$.

The second search unit SU[1] is derived by adding $(dx[0], dy[0])$:

$SU[1].x = SU[0].x + dx[0]*4$, and $SU[1].y = SU[0].y + dy[0]*4$.

In general, we have:

$SU[i+1].x = SU[i].x + dx[i]*4$, and $SU[i+1].y = SU[i].y + dy[i]*4$.

When SU[i] is out of range, it is either always skipped or always wrapped depending on the SU wrapping flag.

When the SU wrapping flag is on, it is equivalent to as we perform

$SU[i].x = SU[i].x(\text{mod } \text{ref_win_width})$, and

$SU[i].y = SU[i].y(\text{mod } \text{ref_win_height})$,

As a convention, a NULL delta marks the end of the search path.

Fixed and Adaptive Search Paths

A *fixed pattern motion search algorithm* is an algorithm following some predefined SP with the designated **MaxNumSU** (*maximal number of search units*) less than or equal to **LenSP** (*the fixed search path length*). This is referred to as *fixed pattern searching* or *predetermined searching*.

When **MaxNumSU** > **LenSP**, (the maximal number of SU is more than what are given by the SP), the searching continues unless reaching a local minimum, which is called *dynamic searching* or *adaptive searching* or *gradient searching*. In this case, the current best result is used. If it is located in some SU boundary, the neighborhood SUs are checked and any one of them that is yet-to-be-searched will be the next SU to be searched. If all neighbor SUs are done, the process of IME is done. *Fixed and Adaptive Search Paths* illustrates on how neighbor SUs are defined for dynamic search.

Hardware maintains one scoreboard per reference to keep track of the state of SUs, whether being searched or yet-to-be-searched. When dual records are enabled on a single reference, both records share the same scoreboard for the reference.

Sample Neighborhood SUs in a Dynamic Search

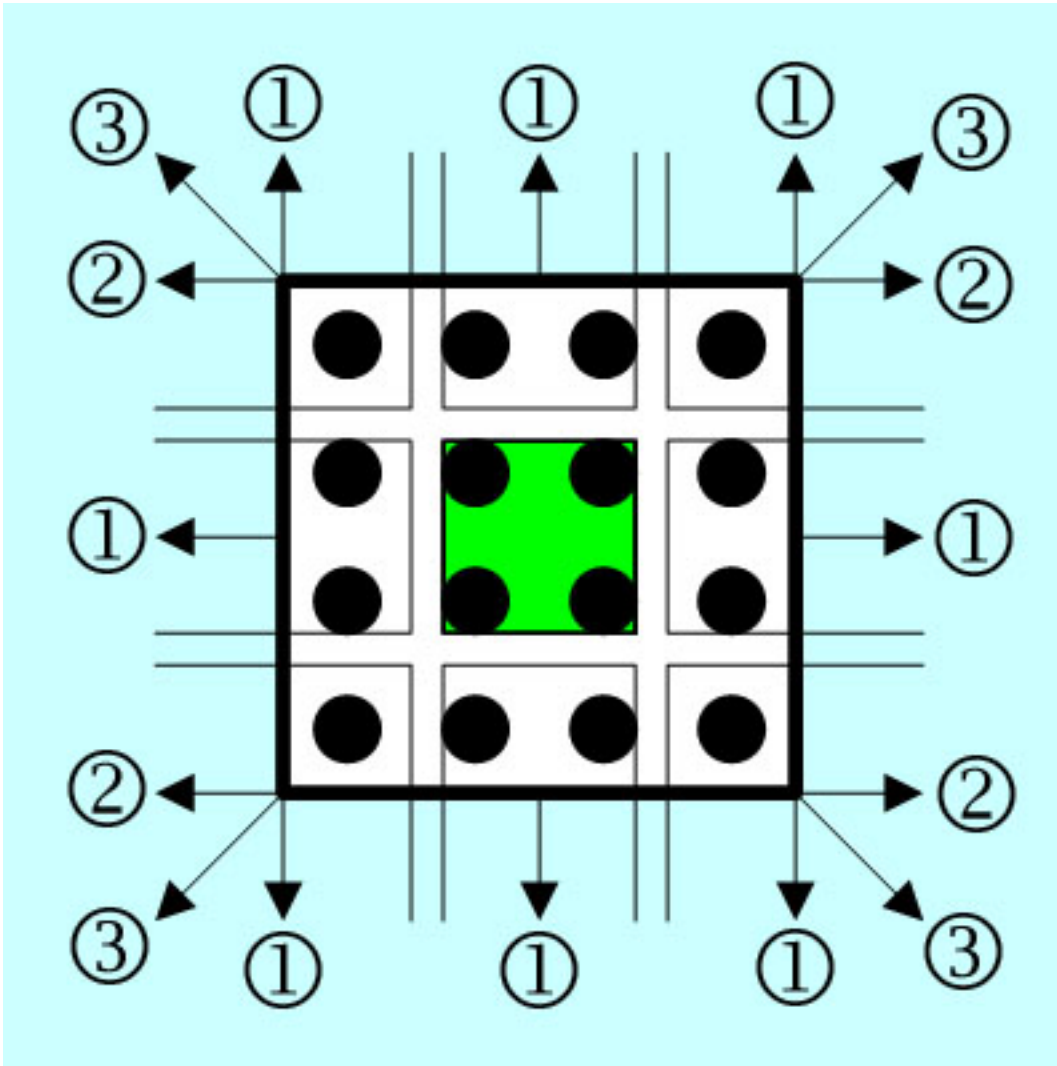

Fixed and Adaptive Search Paths shows the algorithm of this integrated solution. In order to hide the decision logic of dynamic walking, the one-step-delayed-queue is implemented. So when searching the current SU, the next SU is put in the queue. If there are more SUs yet to be searched in the current SP, the next SU is the next SU according to SP; if there is no more SU from SP, the first unsearched neighbor SU (in some predefined order) based on the current best result will be put instead, and if there is no more unsearched neighbor SU, the integer searching terminates.

To reduce the one-step-delay, and to support bidirectional, we create the dual mode that allows the above algorithm to be ping-ponged between two search paths. *Fixed and Adaptive Search Paths* illustrates this case.

In both figures, the best MVs refer to the best resulting motion vectors so far. There are potentially total 41 motion vectors (1 for 16x16, 2 for 16x8, 2 for 8x16, 4 for 8x8, and 32 more for 8x4, 4x8, and 4x4 cases).

The current hardware implementation only considers the four 8x8 MVs.

VME in Single SP Mode

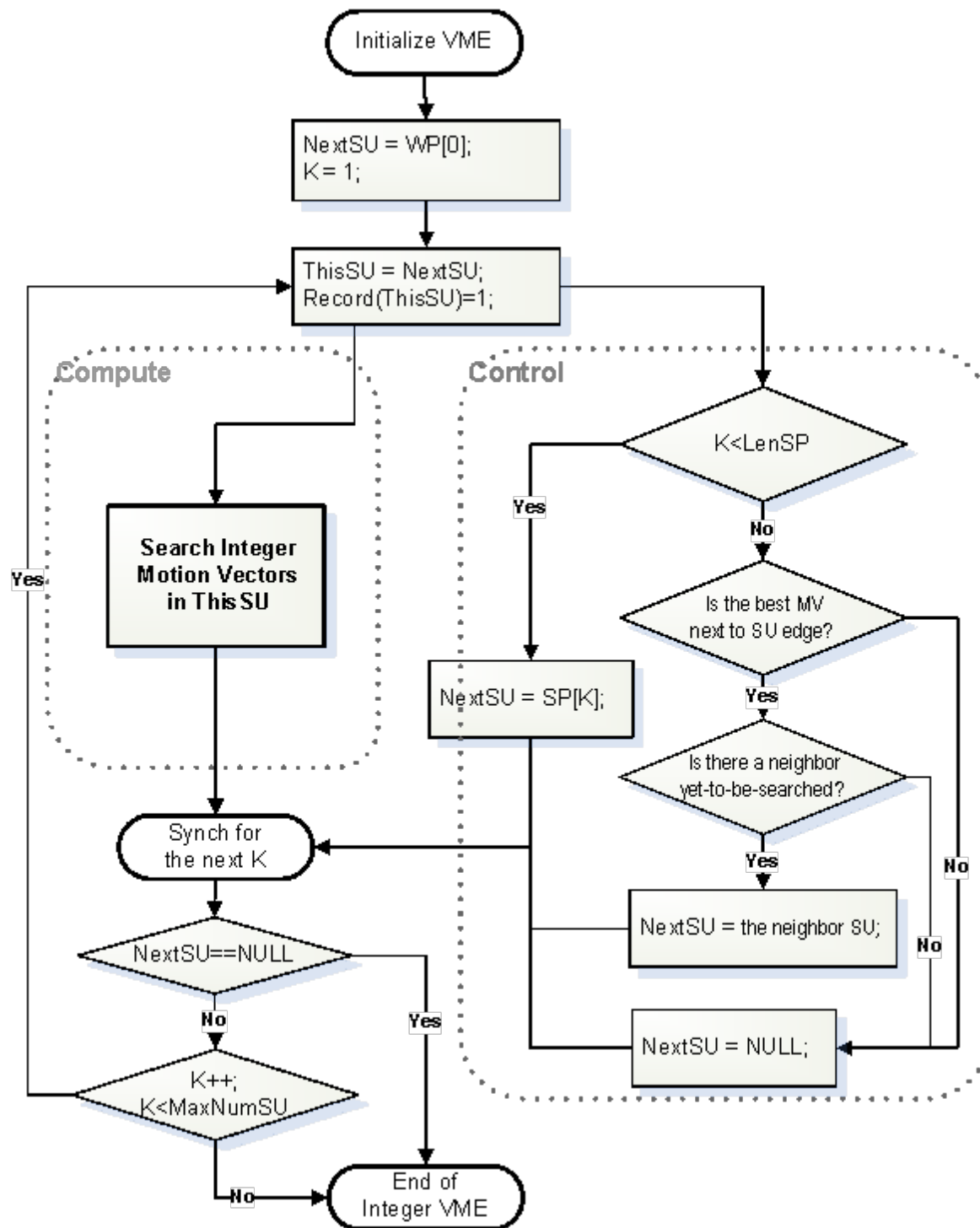

VME in Dual SP Mode

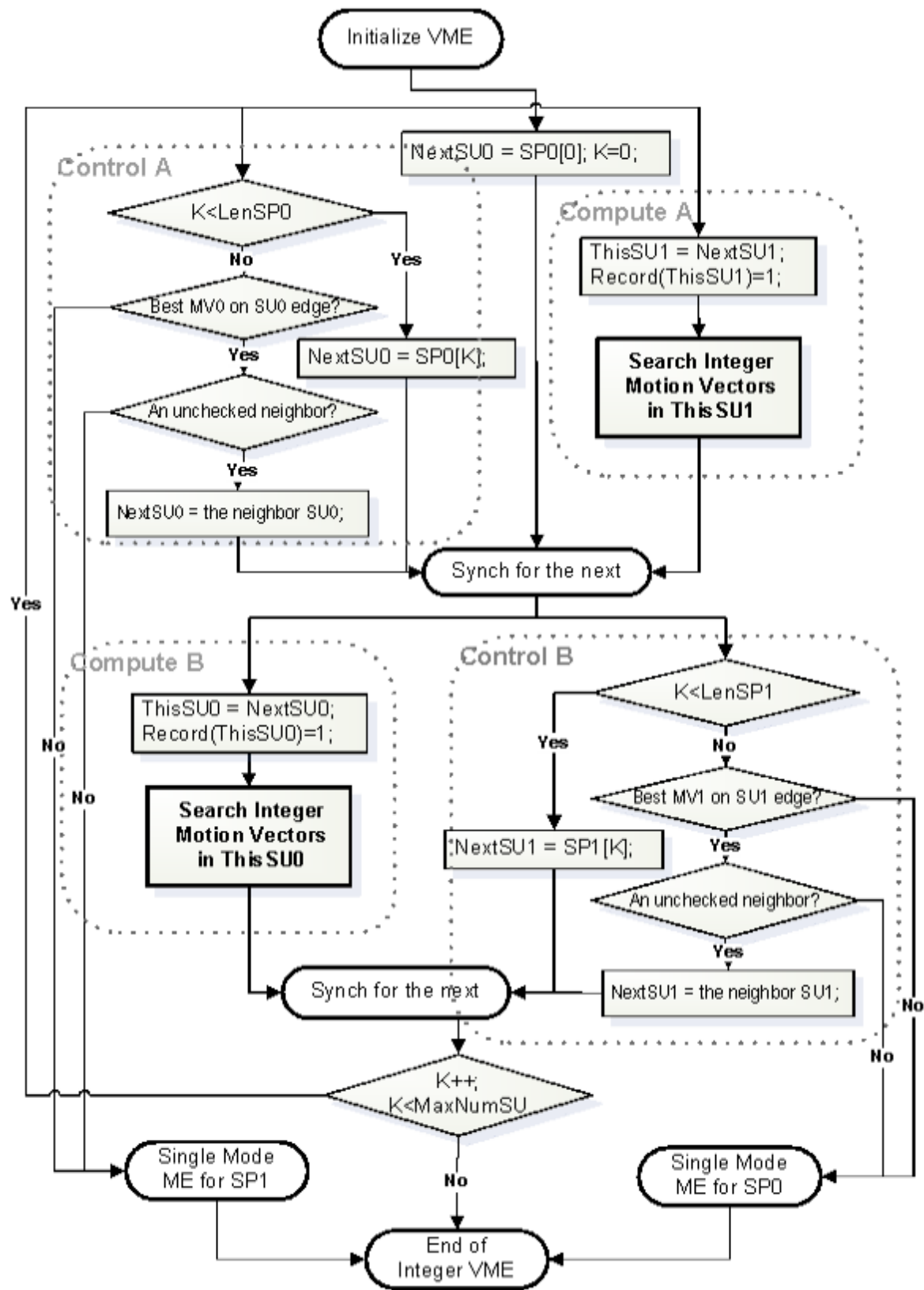

Fractional Motion Estimation

Instead of following the exact interpolation as specified by the individual video standards, 4 tap interpolation is used for the Fractional Motion Estimation (FME) step in the VME engine. It is expected to be adjusted according to different standards.

Interpolations

Instead of following the exact interpolation as specified by the individual video standards, fixed 4 tap interpolation is used in the VME engine, as defined below:

1. $(-1,5,5,-1)/8$ for $\frac{1}{2}$ -pel, i.e. $s = (-P1+P2*5+P3*5-P4+4)/8$ and
2. $(-1,13,5,-1)/16$ for $\frac{1}{4}$ -pel position, i.e. $c = (-P1+P2*13+P3*5-P4+8)/16$.

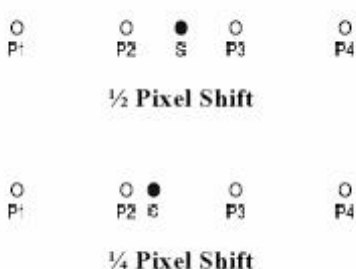

Fractional pixel locations

The quarter-pels are actually the averages of its nearest integer and half pixel values.

It is not hard to see our suggested interpolation formulas are very much the good approximations of the formulas from various standards

For AVC, they should be the following 6-tap formulas in theory:

1. $(1, -5,20,20,-5,1)/32$ for $\frac{1}{2}$ -pel, i.e. $s = ((P2+P3)*20-(P1+P4)*5+(F0+F6)$, and
2. $(1,-5,52,20-5,-1)/64$ for $\frac{1}{4}$ -pel position.. n.

For VC-1, the 4-tap filters are precisely defined:

1. $(-1,9,9,-1)/16$ for $\frac{1}{2}$ -pel, and
2. $(-4,53,18,-3)/64$ for $\frac{1}{4}$ -pel position.

In general, bilinear interpolation is accepted too:

1. $(0,1,1,0)/2$ for $\frac{1}{2}$ -pel (as used in MPEG2), and
2. $(0,3,1,0)/4$ for $\frac{1}{4}$ -pel position.

After IME is done, if the best Inter result is too bad, we may decide to stop the Inter-search to not waste the effort further computationally. If we decided to continue, we have the option to decide shape first to cut down FME calculation or to perform FME for all possible configurations.



VME performs the sub-block level intermediate shape decision first (see *Shape Decision* section for detail), then perform FME only for the reduced candidate shapes. In this way, the computation is reduced significantly with tunable small quality hit.

8+8 vs. 7x7

With a given sub-block of motion vector search, we also have multiple options to pursue the searching. Name two common extremes: 7x7 and 8+8.

Given an integer motion vector location, surrounding it there are 48 surrounding quarter-pel locations, and among them there are 8 are in half-pel grids. So we may check all 48, which covers the 7x7 region, for the best, or we may adopt a two-step approach by considering the half-pel grids first then followed by the second step of the quarter-pel refinement.

The one step method is named as 7x7, and the two step method called 8+8 as only 16 block comparisons are performed as shown in the next figure.

VME hardware follows the 8+8 approach.

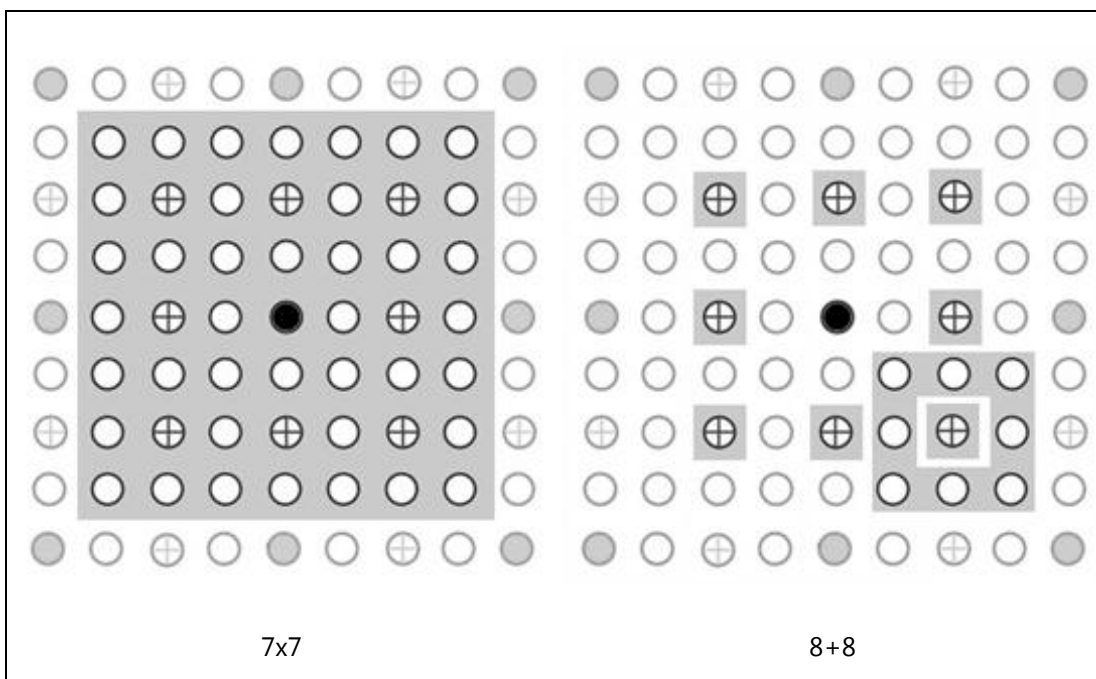

7x7 vs. 8+8, whereas the 8+8 method is used by VME

Partitioning Refinement

When the partitioning refinement is enabled, the FME refinement results will be propagated to or sub-blocks as well, and a shape partitioning will be redone after the completion of both half-pel and quarter-pel searching for a possible better choice.

In the case when alternative candidate is enabled, both half-pel refinements are done in parallel, and then records are combined. Then, both quarter-pel refinements are done again in parallel, and combined



again prior to the final repartitioning. In HW implementation, we do the coarser on first, and the finer one later to achieve the above equivalence.

BME and Weighted Prediction

Bidirectional searching is performed to all candidate shapes.

A weighted bidirectional search is supported particularly for AVC implicit weighted prediction. Only a common subset of frame relations, which falls into linear interpolation with positive weight, is implemented. The weight between forward and backward is approximated into 5 cases only: 16 (quarter distance like Rf B X X Rb), 21 (one third distance like Rf B X Rb), 32 (half distance like Rf B Rb), 43 (two third distance like Rf X B Rb), and 48 (three quarter distance like RXXBR). Here the notation is for bidirectional prediction with display picture order, whereas Rf stands for forward reference, Rb for backward reference, B for the current bidirectional predicted picture and X is another picture in the sequence.

So if the forward prediction is {Ref0[i]}, and the corresponding backward reference is {Ref1[i]}, then the combined bidirectional motion prediction is calculated as the following:

$$\text{Ref}[i] = ((64-\alpha)*\text{Ref0}[i] + \alpha*\text{Ref1}[0] + 32)>>6;$$

where, **alpha** is one of the 5 weighting numbers mentioned above.

Skip Check

There are two SKIP modes:

- **SKIP_1MVP** – one MV pair for 16x16 macroblock, and
- **SKIP_4MVP** – four MV pairs for four 8x8 subblocks.

Otherwise, when Skip Check is enabled and the skip MV number does not exceed **MaxMumMV**, VME will first perform the fractional motion estimation at the skip centers provided by the motion vector pairs as specified by the corresponding mode. In this case the following distortions will be calculated:

1. **RawSkipDist** – (intended for AVC PB_Skip) the raw SAD/HAAR distortion calculated from the skip motion vectors with no costing added.
2. **NonSkipDist** – (intended for AVC B_Direct16x16) the adjusted non-skip distortion is defined by adding optionally the zero motion vector cost and 16x16 Inter mode penalty to **RawSkipDist**. And
3. **NonSkip8x8Dist[4]** – (intended for AVC B_Direct8x8) the four adjusted non-skip distortions for four individual 8x8 subblocks with the ZMV cost and 8x8q Inter mode penalty optionally added. (Note: This case may produce partitions with 8x8 subblock even if the 8x8 subblock shape is disabled.)

Optional implies whether add or not is purely depends on two enabling input bits: **NonSkipModeAdded** and **NonSkipMvAdded**. It should be also noted that MODE_INTER_BWD is not added to **NonSkipDist** or **NonSkip8x8Dist[]** even though a skip center contains backward motion vector (this is for a direct



mode, whether the motion vector for a block is forward, backward or bidirection is derived from its spatial or temporal predictor and there is no coding cost).

If **RawSkipDist** is less than or equal to **EarlySkipSuccess** threshold, **MinDist** will be set to **RawSkipDist** if the skip MV number does not exceed **MaxMumMV**.

- If **EarlySuccessEn** flag is on, VME exits immediately afer setting **MbSkipFlag** on, and **Direct8x8Pattern** = Fh.
- If **EarlySuccessEn** flag is off, VME continue the IME, FME, BME, and Direct8x8 searching after setting **MbSkipFlag** on and **Direct8x8Pattern** = Fh. VME will choose the skip output unless another better choice of code with less adjusted distortion is found.

If **RawSkipDist** is greater than **EarlySkipThreshold**, **MinDist** will be set to **NonSkipDist** if the skip MV number does not exceed **MaxMumMV**. **MbSkipFlag** will be always set to off. VME continue the IME, FME, BME, and Direct8x8 searchings. VME will still choose the skip output (with **MbSkipFlag** off) unless another better choice of code with less adjusted distortion is found.

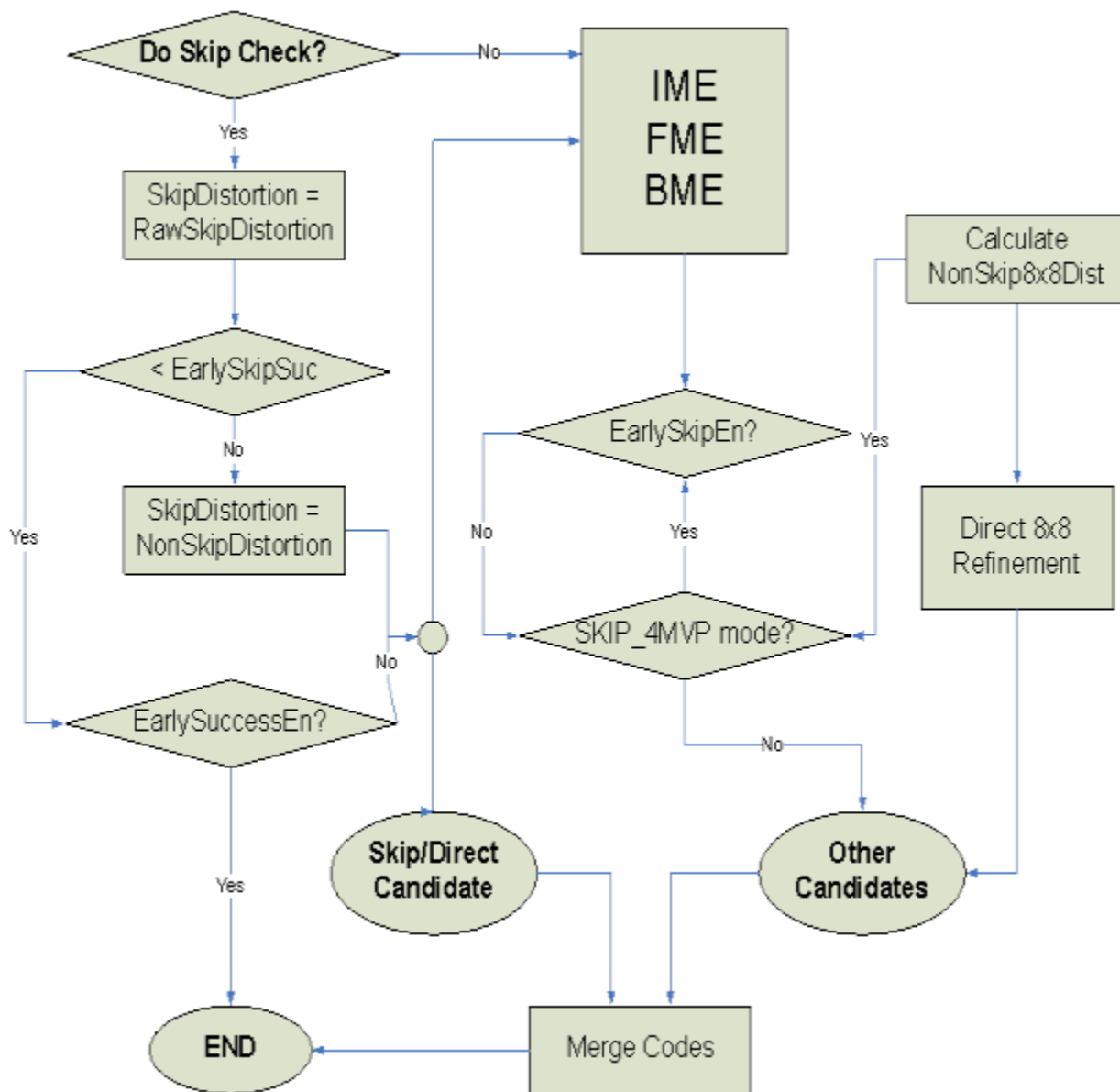

Direct 8x8 Search

Direct8x8 Searching and then possible replacement is performed ONLY for 16x16 source block.

Direct8x8 Searching is performed only for **Skip_4MVP** mode when skip check is on to candidates of MbType in a partition that is in the Inter shape of 8x8 or minors, after IME, FME, and BME searchings.

For each candidate in 8x8 or smaller partition, and for each 8x8 sub-block, the corresponding codes will be replaced by the skip motion vector (pair) of the same 8x8 subblock, if all of the following requirements are satisfied:



- The non-skip 8x8 distortion **NonSkip8x8Dist[k]** is less than or equal to the adjusted 8x8 distortion of the corresponding codes.
- The merge does not violate uni-mix and bi-mix rules (the violating cases are skipped).
- The number of MVs used for the candidate adding the number of subblocks of the shape 8x8 must be less than or equal to **MaxNumMV**. Or otherwise it does not replace a uni-directional 8x8 MV with a true bi-directional skip MV pair.

Note that, during all of the above comparisons, we skip the process whenever the MV numbers exceeding the **MaxNumMV**.

If either **UniMixDisable** or **BiMixDis** is set, then there would be no direct8x8 block level replacement.

Skip Check Only Mode

VME supports the skip check only mode, when **Intra** is set off, **Inter** and **Skip** are enabled, and all 7 inter shapes (**SubMbPartMask**): 16x16, 16x8, 8x16, 8x8, 8x4, 4x8, and 4x4 are set to 1 (all sub partitions are turned off). That indicates that none of the partition and sub partitions are valid for IME. Therefore IME is not performed, and no subsequent FME/BME is performed. This is another performance optimization choice if the intended usage is to check the skip centers only.

Intra Prediction Estimation

Intra Prediction Estimation state supports all Intra16x16, Intra8x8, and Intra4x4 modes. All predictions are based on original frame pixels for quick performance, as widely adopted in HW industry. There is a known quality drop.

For supporting AVS as well as providing finer knobs for AVC, five enabling flags are defined:

- Enable Intra16x16: whether Intra16x16 shall be performed.
- Enable Intra8x8: Enable all Intra8x8 modes, and the next flag determines which ones are actually performed.
- AVS Intra8x8 Flag: whether should perform the subset of 5 AVS modes or perform the super set of 8 AVC modes.
- Enable Intra4x4: Enable all Intra4x4 modes, and the next flag determines which ones are actually performed.
- AVS Intra4x4 Flag: whether should perform the subset of 5 AVS modes or perform the super set of 8 AVC modes.

Transform Adjusted SAD

A simple Wavelet transform, Haar transform, is used to refine the cost function measure of SAD. The per pixel difference goes through a 4x4 Haar transform. Then the SAD is replaced by the sum of the absolute values the transform domain coefficients (L1 norm) in the cost function. Haar transform here is used as a coarse estimation of the integer transform.

Assume the 4x4 block **Blk** is given in the following order:



```

0  1  2  3
4  5  6  7
8  9 10 11
12 13 14 15

```

The 4x4 Haar transform is performed using cascaded 2x2 Haar filters of the following steps:

- Four 4-tap row filter
- Two 4-tap column filter
- Two 2-tap row filter
- Two 2-tap column filter

Where the 2x2 Haar transform is given as:

```

1  1
1 -1

```

	<pre> x00 x01 x02 x03 x10 x11 x12 x13 x20 x21 x22 x23 x30 x31 x32 x33 </pre>	<pre> 1 0 1 0 1 0 -1 0 0 1 0 1 0 1 0 -1 </pre>
<pre> 1 1 0 0 0 0 1 1 1 -1 0 0 0 0 1 -1 </pre>	<pre> t00 t01 h08 h09 t02 t03 h10 h11 t04 t05 h12 h13 t06 t07 h14 h15 </pre>	
	<pre> t00 t01t02 t03 h04 h05 h06 h07 </pre>	<pre> 1 1 1 -1 </pre>
<pre> 1 1 1 -1 </pre>	<pre> t00 h02 t01 h03 </pre>	
	<pre> h00 h01 </pre>	

This is equivalent to the following pseudo code functions:

```

void Haar(short Blk4x4[16], short Haar4x4[16])
{
    short Tmp[16];
    // First level 4-element horizontal Haar for 4 rows:
    for ( int i=0; i<8; i++ ) {
        Haar4x4[8+i] = (Blk4x4[i*2] - Blk4x4[i*2+1]);
        // Storing LP 2x4 in scan order:
        Tmp[i] = (Blk4x4[i*2] + Blk4x4[i*2+1]);
    }

    // First level 4-element vertical Haar for 2 columns:

```



```
Haar4x4[4] = (Tmp[0] - Tmp[2]);
Haar4x4[5] = (Tmp[1] - Tmp[3]);
Haar4x4[6] = (Tmp[4] - Tmp[6]);
Haar4x4[7] = (Tmp[5] - Tmp[7]);

// Storing LP 2x2 in scan order:
Tmp[0] = (Tmp[0] + Tmp[2]);
Tmp[1] = (Tmp[1] + Tmp[3]);
Tmp[2] = (Tmp[4] + Tmp[6]);
Tmp[3] = (Tmp[5] + Tmp[7]);

// Second level 2-element horizontal Haar for 2 columns:
Haar4x4[3] = (Tmp[0] - Tmp[1]);
Haar4x4[2] = (Tmp[2] - Tmp[3]);

// Storing LP 1x2:
Tmp[0] = (Tmp[0] + Tmp[2]);
Tmp[1] = (Tmp[1] + Tmp[3]);

// Second level 2-element vertical Haar:
Haar4x4[1] = (Tmp[0] - Tmp[1]);
Haar4x4[0] = (Tmp[0] + Tmp[1]);
}

int AdjustedSAD(BYTE Src[16], BYTE Ref[16])
{
    short diff[16], diffH[16];
    for ( int i=0; i<16; i++ ) diff[i] = r[i]-s[i];
    Haar(diff, diffH);
    intasad = 0;
    for ( int i=0; i<16; i++ ) asad += (diff[i] < 0 ? -diff[i] : diff[i]);
    asad >= (12 - DISTBIT4X4);
    return (asad);
}
```

Thus instead of calculating the SAD of the actual pixel values, now we apply SAD to the after transformation values.

As the Haar transform basis vectors have a magnitude of $\frac{1}{2}$, instead of the normalized Haar of $1/\sqrt{2}$, the resulting transformed coefficients maintain the same bit precision as the input. Thus the sum tree has the same precision as without the transform adjustment. However, this version of the Haar transform has low weightings on the DC and low AC terms, which may not be optimal as a motion-search cost function.

Early Decisions

There are 5 programmable early decision states available for fine control of the VME process. All stored in one byte of U4U4 format to representing a value of (B<S), (where B, called **base**, is the 4-LSB of the byte and S, called **shift**, is the 4-MSB of the byte,) they are the following:

- a) ESS: EarlySkipSuccess = Early successful return after Skip is checked
- b) EIS: EarlyImeStop = Early IME stop when a good match is found inside of IME process.
- b) ITG: ImeTooGood = Early successful return after IME is done when a good enough match is found.
- a) ITB: ImeTooBad = Early termination do skip fractional and bidirectional refinement after IME is done with a hopelessly bad match as the best result.

c) EFS: EarlyFmeSuccess = Early Success after Fractional ME to skip bidirectional search.

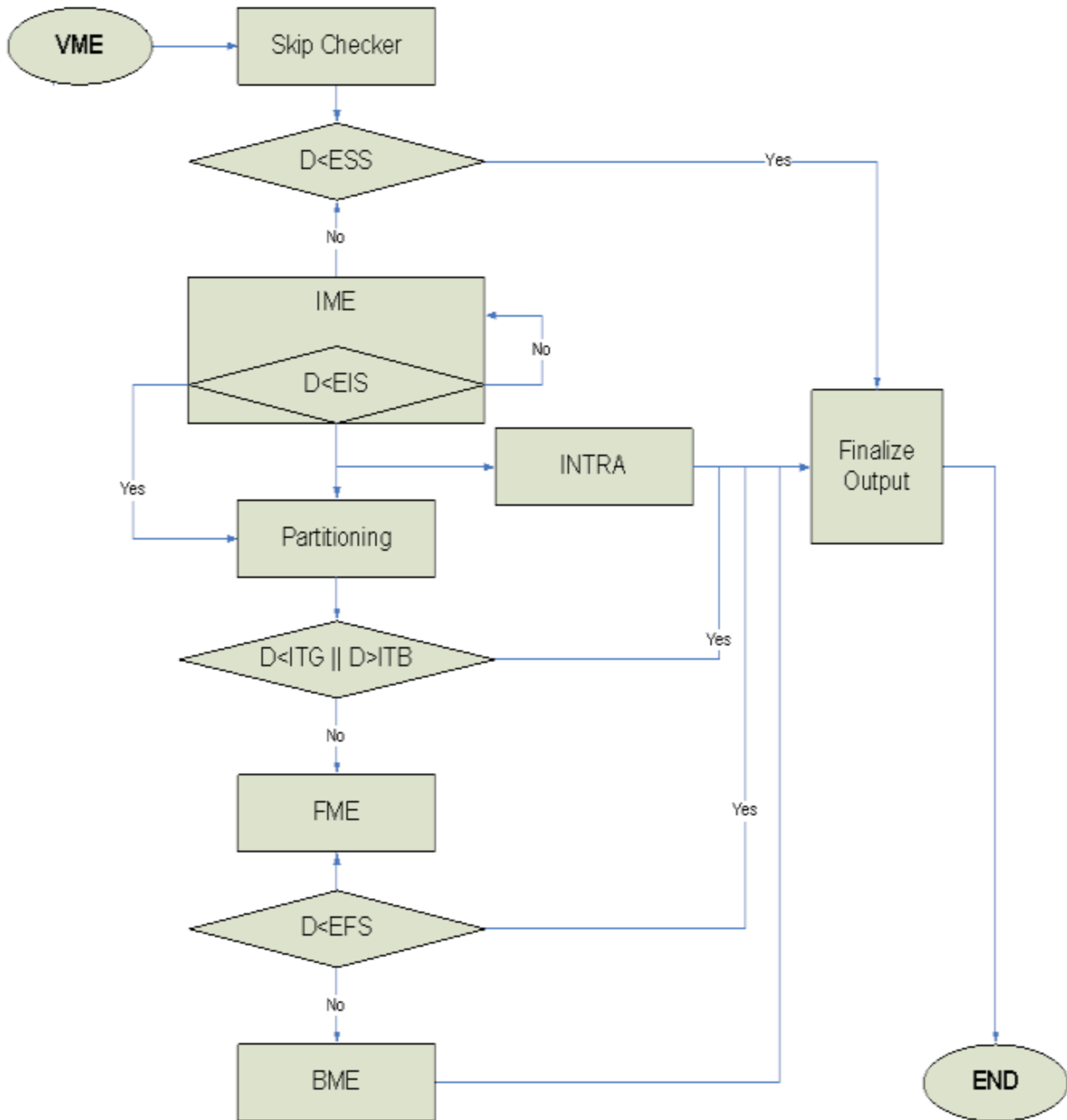

Note. For any reason, if all possible code types are not chosen, VME will return Intra16x16 type with all modes set to 0, and the **MinDist** is set to 0x3FFF.



Performance Information

VME makes many internal decisions such as whether or not early exits occurred. Additionally, the number of search units processed and the total clocks spent per message are valuable to software for real-time adjustments or testing and statistical analysis. VME output message contains such information to fulfill this basic feature.

The output message for VME contains fields to encode decision and performance counters. This includes performed sub-functions (IME, FME, BME, etc), the early exit conditions, and other internal decisions.

Of the *other* internal decisions, there are fields for whether or not FME or BME improved the primary candidate. These bits will be set when FME or BME modifies the best mv decision. If the *alternate partition* or *extra candidate* results in a lower cost at the end of VME, a bit will be used to represent that the alternate beat the original best. Lastly, 1 bit will be used to indicate partitioning was constrained by MaxMV. For example, if 16x16 was the lowest sad+cost and MaxMV was set to 10, the partitioning was not constrained. However, if 8x8 was the lowest sad+cost and MaxMV was set to 1, partitioning was constrained by MaxMV and this bit would be set.

There are also 3 counter values. One is to report the total number of search units processed by the back-end (max is 48). Another is to report the total time the front-end is starved due to cache misses, counted in divisions of 16 clocks (max is 1024*16 clocks). This will most likely be active at the beginning of a VME request, however, even after processing has begun, if any front-end stalls occur this counter should resume counting. Hence, when the VME request has finished, this counter will have the total time the front-end is stalled. The third field is used to report the total time the back-end consumed for computation, also counted in divisions of 16 clocks (max is 256*16 clocks) [**Note:** this should include any bubbles in the pipe, simply put, if front-end is not stalled, this counter should be free-running]. Thus, by adding total front-end starved time with total back-end computation time, the exact total VME message time can be obtained.

Changes

VME will retain the grand majority of previous VME features; however a new programming model is required. Additionally, new features have been added. Overall, the engine is more flexible, has more features and is faster than previous generations. See *Haswell New Features Overview* for further details.

Surfaces

The data elements accessed by VME are called *surfaces*. Surfaces are accessed using the surface state model.

VME uses the binding table to bind indices to surface state, using the same mechanism used by the sampling engine. A **Binding Table Index** (specified in the message descriptor) of less than 255 is used to index into the binding table, and the binding table entry contains a pointer to the SURFACE_STATE. SURFACE_STATE contains the parameters defining the surface to be accessed, including its location, format, and size.



State

BINDING_TABLE_STATE

VME uses the binding table to retrieve surface state. Refer to *Sampling Engine* for the definition of this state.

SURFACE_STATE

VME uses the surface state for current and reference surfaces. Refer to *Sampling Engine* for the definition of this state.

VME_STATE

This state structure contains the state used by the VME engine for data processing. VME state contains the motion search path location tables and rate-distortion weight look-up-tables. As the two sets of tables are fairly large, they are accessed as two separate states via state indexing mechanism so that applications can inter-mix the use of the search path tables and RDLUT tables.

Even though VME engine has its unique shared function ID (see Target Function ID field in the SEND instruction), the VME state is delivered through the Sampler State Pointer. When the General Purpose Pipe is used, the **Sampler State Pointer** is programmed in the MEDIA_INTERFACE_DESCRIPTOR_LOAD command and delivered directly to Sampler/VME by hardware. This posts one usage limitation. As the VME state is overloaded on top of the Sampler State Pointer, VME messages cannot be intermixed with other Sampler messages.

Each VME state may contain up to 8 VME_SEARCH_PATH_LUT_STATE. When multiple VME_SEARCH_PATH_LUT_STATE are used, they need to be stored in memory contiguously. Each VME_SEARCH_PATH_LUT_STATE contains 32 dwords in comparison of 4 dwords of a Sampler State. When enabling sampler state pre-fetch (programming the **Sampler Count** field in the MEDIA_INTERFACE_DESCRIPTOR_LOAD command), one VME_SEARCH_PATH_LUT_STATE is equivalent to 8 Samplers. Hardware may support up to two VME_SEARCH_PATH_LUT_STATE to be pre-fetched (See See 3D_Media_GPGPU chapter, Media_GPGPU_Pipeline for more details).

VME_SEARCH_PATH_LUT_STATE

Up to eight VME_SEARCH_PATH_LUT_STATE allowed for a message to select. Each state contains one set of search path locations, and four sets of rate distortion cost function LUT for various modes and rate distortion cost function LUT for motion vectors (relative to *cost center*). Motion vector cost function is provided as a piece-wise-linear curve with only the values of the power-of-2 positions provided.

DWord	Bit	Description
0:13		Search Path
0	31:24	Search Path Location [3] (X, Y) – Relative distance from location [2]



DWord	Bit	Description
	23:16	Search Path Location [2] (X, Y) – Relative distance from location [1]
	15:8	Search Path Location [1] (X, Y) – Relative distance from location [0]
	7:4	Search Path location [0] (Y) – specifies relative Y distance of the next walk from the starting position in unit of Search Unit (SU) in U4 Format = U4, (e.g. 0x3 + 0xE = 0x1)
	3:0	Search Path Distance [0] (X) – specifies relative X distance of the next walk from the starting position in unit of SU. Format = U4
1:13		Search Path Location [4 – 55] (X, Y)
14:31		RD LUT SET 0-4
14	31:24	LUT_MbMode [9] for Set 1 Format = U4U4 (encoded value must fit in 12-bits)
	23:16	LUT_MbMode [8] for Set 1 Format = U4U4 (encoded value must fit in 12-bits)
	15:8	LUT_MbMode [9] for Set 0 Format = U4U4 (encoded value must fit in 12-bits)
	7:0	LUT_MbMode [8] for Set 0 Format = U4U4 (encoded value must fit in 12-bits)
15	31:24	LUT_MbMode [9] for Set 3 Format = U4U4 (encoded value must fit in 12-bits)
	23:16	LUT_MbMode [8] for Set 3 Format = U4U4 (encoded value must fit in 12-bits)
	15:8	LUT_MbMode [9] for Set 2 Format = U4U4 (encoded value must fit in 12-bits)
	7:0	LUT_MbMode [8] for Set 2 Format = U4U4 (encoded value must fit in 12-bits)
16	31:24	LUT_MbMode [3] for Set 0 Format = U4U4 (encoded value must fit in 12-bits)
	23:16	LUT_MbMode [2] for Set 0 Format = U4U4 (encoded value must fit in 12-bits)
	15:8	LUT_MbMode [1] for Set 0 Format = U4U4 (encoded value must fit in 12-bits)
	7:0	LUT_MbMode [0] for Set 0 Format = U4U4 (encoded value must fit in 10-bits)
17	31:24	LUT_MbMode [7] for Set 0 Format = U4U4 (encoded value must fit in 10-bits)



DWord	Bit	Description
	23:16	LUT_MbMode [6] for Set 0 Format = U4U4 (encoded value must fit in 10-bits)
	15:8	LUT_MbMode [5] for Set 0 Format = U4U4 (encoded value must fit in 10-bits)
	7:0	LUT_MbMode [4] for Set 0 Format = U4U4 (encoded value must fit in 12-bits)
18	31:24	LUT_MV [3] – For MV = 4 for Set 0 Format = U4U4 (encoded value must fit in 10-bits)
	23:16	LUT_MV [2] – For MV = 2 for Set 0 Format = U4U4 (encoded value must fit in 10-bits)
	15:8	LUT_MV [1] – For MV = 1 for Set 0 Format = U4U4 (encoded value must fit in 10-bits)
	7:0	LUT_MV [0] – For MV = 0 for Set 0 Format = U4U4 (encoded value must fit in 10-bits)
19	31:24	LUT_MV [7] – For MV = 64 for Set 0 Format = U4U4 (encoded value must fit in 10-bits)
	23:16	LUT_MV [6] – For MV = 32 for Set 0 Format = U4U4 (encoded value must fit in 10-bits)
	15:8	LUT_MV [5] – For MV = 16 for Set 0 Format = U4U4 (encoded value must fit in 10-bits)
	7:0	LUT_MV [4] – For MV = 8 for Set 0 Format = U4U4 (encoded value must fit in 10-bits)
20-23		Finish RD LUT SET 1
24-27		Finish RD LUT SET 2
28-31		Finish RD LUT SET 3

The assignment of LUT_MbMode entries is according to the MbTypeEx definition:

Index to LUT_MbMode	MbTypeEx	Description	AVC	VC1	MPEG2
0	MODE_INTRA_NONPRED	For INTRA8x8 and INTRA4x4 only. Added per 8x8 for INTRA8x8, and per 4x4 for INTRA4x4	Yes	n/a	n/a
1	MODE_INTRA MODE_INTRA_16x16	Added per 16x16 macroblock	Yes	Yes	Yes
2	MODE_INTRA_8x8	Added per 16x16 macroblock	Yes	n/a	n/a
3	MODE_INTRA_4x4	Added per 16x16 macroblock	Yes	n/a	n/a
8	MODE_INTER MODE_INTER_16x16	Added per 16x16 macroblock	Yes	Yes	Yes



Index to LUT_MbMode	MbTypeEx	Description	AVC	VC1	MPEG2
9	MODE_INTER_BWD	Added for RefIdx (per partition for major type or 8x8 for minor types)	Yes	Yes	Yes
4	MODE_INTER_16x8 MODE_INTER_8x16	Added per 16x16 macroblock	Yes	n/a	n/a
5	MODE_INTER_8x8q	Added per 8x8 subblock	Yes	Yes	n/a
6	MODE_INTER_8x4q	Added per 8x8 subblock	Yes	n/a	n/a
6	MODE_INTER_4x8q	Added per 8x8 subblock	Yes	n/a	n/a
7	MODE_INTER_4x4q	Added per 8x8 subblock	Yes	n/a	n/a
6	MODE_INTER_FIELD_16x8	Added per 16x16 macroblock	n/a	?	Yes
7	MODE_INTER_FIELD_8x8q	Added per 16x16 macroblock	n/a	n/a	n/a

The value of each byte of the LUTs will be viewed as a pair of 4-bit units: (shift, base), and constructed as $\text{base} \ll \text{shift}$.

For example, an entry 0x4A represents the value $(0xA \ll 4) = 10 \cdot 16 = 160$. Encoded value must fit in **12**-bits (unsigned number); otherwise, the hardware behavior is undefined.

The only exception is for Index of 9, MODE_INTER_BWD, which is used as a bias for the two search directions. It is a signed number instead, in the form of (SU3U4) = (sign, shift, base). The sign bit indicates whether the bias is added to the forward (if sign = 1) or the backward (if sign = 0). The bias has a magnitude of $(\text{base} \ll \text{shift})$, which has 11-bits precision. It should be noted that the number is always added, there is no subtraction.

Intra Modes only apply to AVC standard. The mode penalty doesn't apply to Skip Mode Checking. Note that while other mode penalty applies to a fixed macroblock partition, MODE_INTRA_NONPRED applies to all three intra modes. It is a constant cost adder for intra-mode coding regardless of the block size.

For source block that is less than 16x16 (like a 16x8 source block), the proper mode penalty that is stated as *added per 16x16 macroblock* is added once to the source block (like MODE_INTER_16x8 is added once to a 16x8 source block). It will not be divided by the source block size.

The LUT_MV is added to all motion vector coordinate deltas in quarter-pel unit except for the SKIP mode, which no costing penalty applies. Given motion vector coordinate, e.g. mv_x , which is in quarter-pel precision (S5.2), the mv delta is defined to be its difference from the given costing center, e.g. cc_x , and the costing penalty is applied to $dx = |mv_x - cc_x|$. The cost penalty is a piecewise linear interpolation from the LUT_MV table whereas the values on power-of-2 integer samples are provided. The piecewise linear interpolation is performed using quarter-pel precision, while the LUT_MV are only provided for the given power-of-2 integer positions. The maximum distance provided in the table is 64 pixels. A linear ramp with gradient of 1 on integer distance is applied for bigger distances with maximum penalty capped to 0x3FF (10 bits). Thus,

$$\text{Costing_penalty_x} = \text{LUT_MV}[\text{int}(dx)], \text{ if } dx < 3 \text{ and } dx = \text{int}(dx);$$



Costing_penalty_x = LUT_MV[p+1], else if $dx = 2^p$, for any $p \leq 6$;

Costing_penalty_x = LUT_MV[p+1] + ((LUT_MV[p+2] – LUT_MV[p+1])*k) > p,
else if $dx = 2^p + k$, for any $p < 6$ and $k < 2^p$, and

Costing_penalty_x = min (LUT_MV[7] + int(dx)– 64, 255), else if $dx > 64$.

The total costing penalty for a motion vector is

Costing_penalty = Costing_penalty_x + Costing_penalty_y

As a convention, a (0,0) relative search path distance (meaning a repeat search path location) is treated as the ending of the search path. Or the search path may also end when **Max Predetermined Search Path Length** is reached, or one of the Early Success conditions is reached.

Software must program the search path to terminate with at least one (0,0).

Haswell New Features Overview

Previously issued PRMs list out numerous features of the VME unit. The VME is by default a superset of those features. However, some features are added and some legacy features are removed (where possible). For deeper familiarity with the VMEs for previous chipsets, see their respective PRMs. Discussion of previous VME instantiations only occurs here when required to explain a new or removed feature.

The new features are listed below and descriptions are provided in the sections that follow:

- IME Repartition (Dedicated IME Pipeline)
- HW Accelerated Chroma Intra
- Improved Skip Decision (FTQ)
- HW Assisted Multi-Reference Support
- Chroma Inter Mode
- Increased SAD Precision

IME Repartition (Dedicated IME Pipeline)

This is the most significant change to VME. It improves both performance (significantly) and flexibility of the unit, but imposes an increase of complexity to the kernel (other features are added with intent of offsetting this burden). VME will be divided into 2 internal pipelines for increased parallelism: the IME message will be given a new dedicated datapath separate from where the SIC and FBR messages will be performed. This added parallelism will increase VME performance on the order of 1.5x.

Specifically, instead of 1 single call to VME where all 5 subfunctions (Skip, Intra, IME, FME, BME) would be performed serially, the VME has been divided into 3 atomic operations that SW can configure anyway it chooses. The final mode decision is done inside the kernel.

- Skip & Intra operations have been joined together in a *Skip & Intra Check* message (SIC).
- Integer Motion Estimation has been isolated in a standalone IME message (IME).



- FME & BME have been combined into a *Fraction & Bidirectional Refinement* message (FBR).

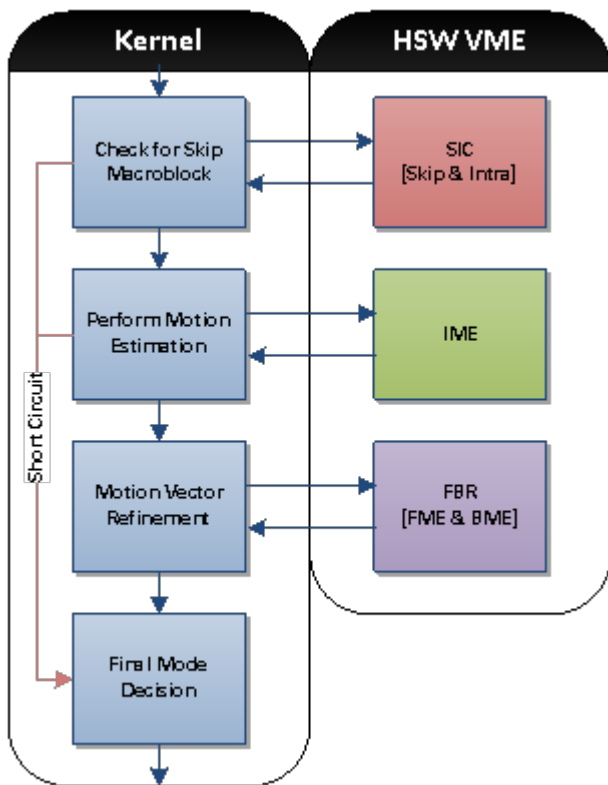

Example Kernel S Pipeline

The preceding figure shows an example SW pipeline to reproduce the HW-managed pipeline of . The following figures show the monolithic and atomic pipelines in more detail.

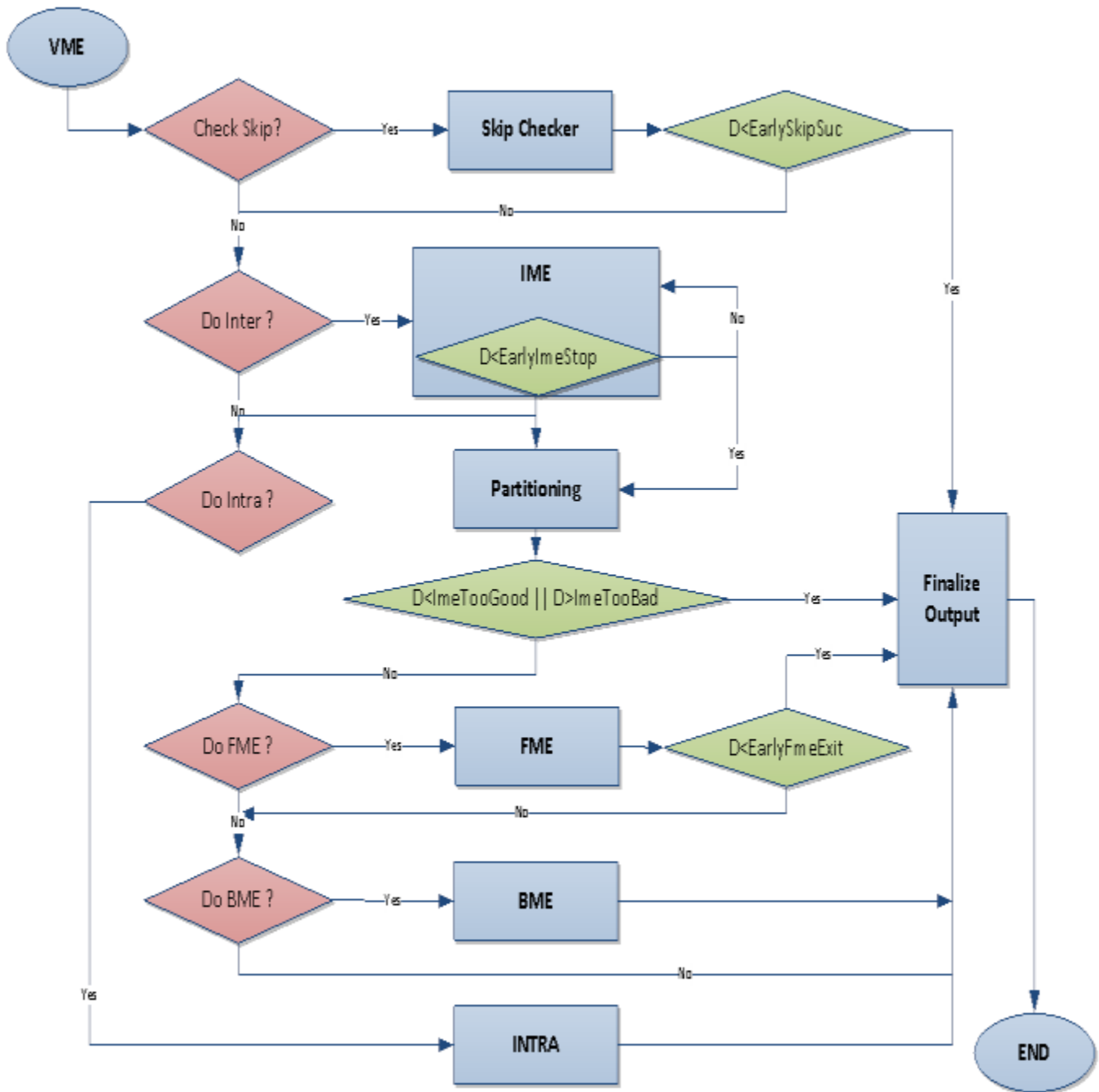

VME Flowchart

The preceding figure shows the HW-managed VME flow, which allows for sub-functions to be enabled\disabled independently and certain exit points to be activated by satisfying a quality threshold.

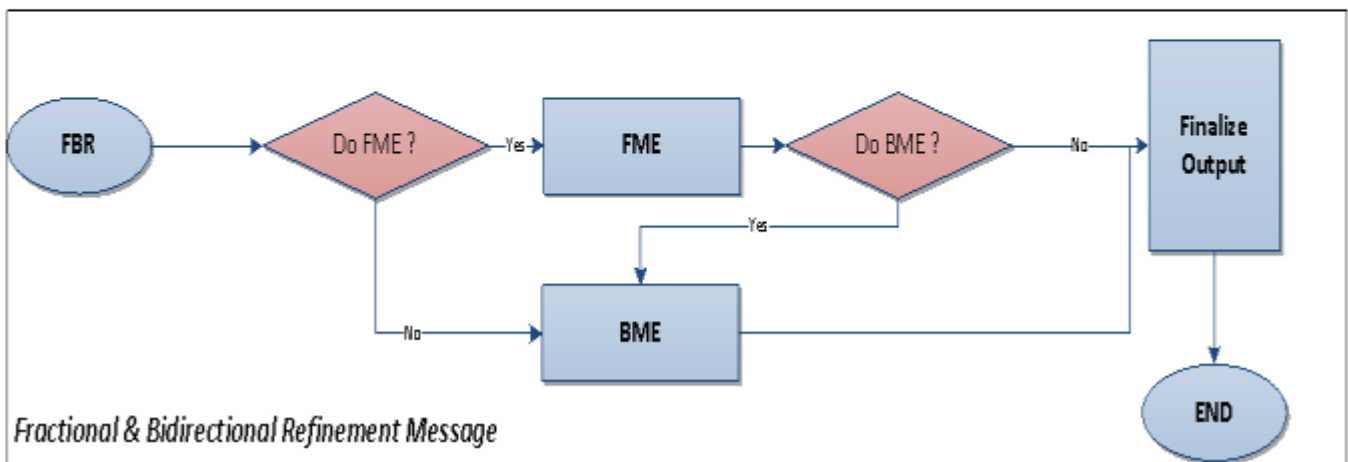
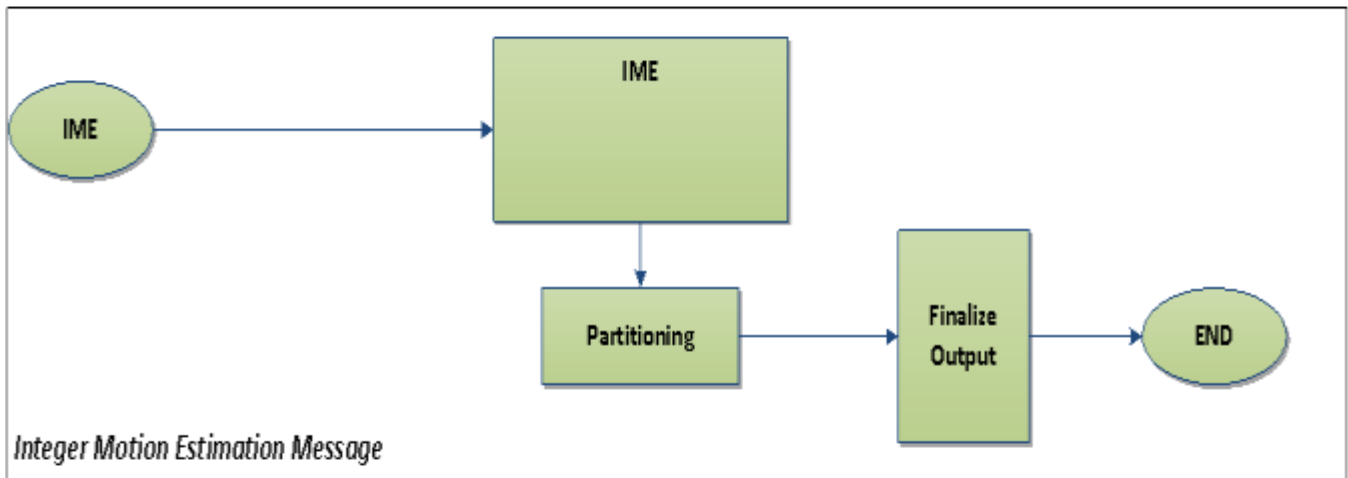
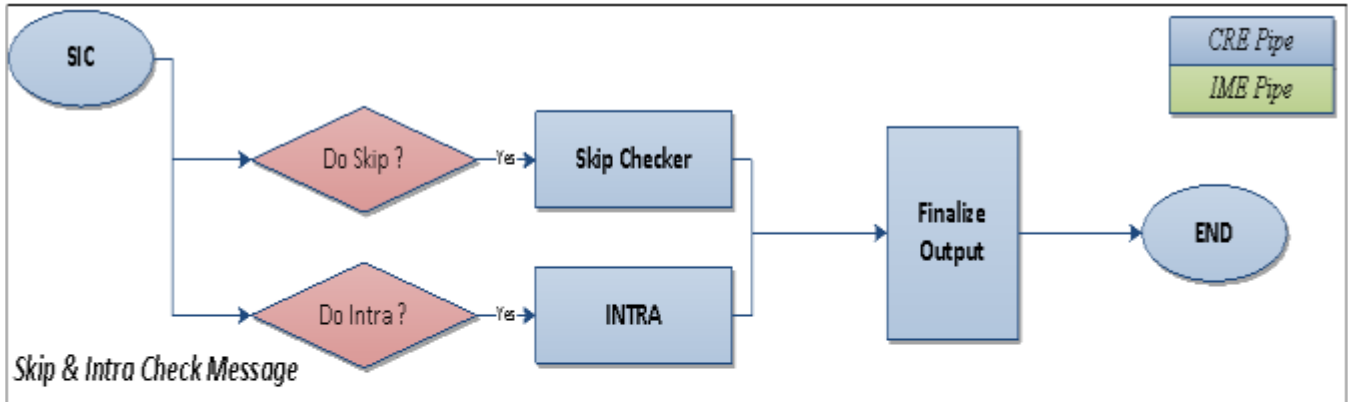

VME Flowchart

The preceding figure shows the managed VME atomic messages, which is similar to VME but split at key points between subfunctions. This is done to isolate IME for performance reasons and provide more flexibility for to SW to innovate.



HW Accelerated Chroma Intra

The chroma mode decision consumes a significant portion of the kernel footprint and time, moving it to HW will offset some of the cost to support the IME repartition. The kernel will fetch the neighbor MBs CbCr pairs and provide them in the SIC message and VME will evaluate the 4 chroma modes and return the mode with the least combined CbCr distortion. Note: only NV12 is supported. A U4U4 value *Chroma Intra Mode Cost* will be used to penalize the different chroma intra modes. DC gets no penalty, Horz & Vert get 1x penalty, and Plane gets 2x added to the final SAD of each mode before VME selects the winner. (e.g. add cost for each mode: DC=0x, Horz=1x, Vert=1x, Plane=2x). The kernel can select HW intra prediction for Y+CbCr, Y only, or no intra prediction. However, all 4 SIC message phases are expected to be sent by the kernel in any of these cases.

Cb	Cr	Cb	Cr	Cb	Cr	Cb	Cr	Cb	Cr	Cb	Cr	Cb	Cr	Cb	Cr	Cb	Cr
Cb	Cr	Cb	Cr	Cb	Cr	Cb	Cr	Cb	Cr	Cb	Cr	Cb	Cr	Cb	Cr	Cb	Cr
Cb	Cr	Cb	Cr	Cb	Cr	Cb	Cr	Cb	Cr	Cb	Cr	Cb	Cr	Cb	Cr	Cb	Cr
Cb	Cr	Cb	Cr	Cb	Cr	Cb	Cr	Cb	Cr	Cb	Cr	Cb	Cr	Cb	Cr	Cb	Cr
Cb	Cr	Cb	Cr	Cb	Cr	Cb	Cr	Cb	Cr	Cb	Cr	Cb	Cr	Cb	Cr	Cb	Cr
Cb	Cr	Cb	Cr	Cb	Cr	Cb	Cr	Cb	Cr	Cb	Cr	Cb	Cr	Cb	Cr	Cb	Cr
Cb	Cr	Cb	Cr	Cb	Cr	Cb	Cr	Cb	Cr	Cb	Cr	Cb	Cr	Cb	Cr	Cb	Cr
Cb	Cr	Cb	Cr	Cb	Cr	Cb	Cr	Cb	Cr	Cb	Cr	Cb	Cr	Cb	Cr	Cb	Cr
Cb	Cr	Cb	Cr	Cb	Cr	Cb	Cr	Cb	Cr	Cb	Cr	Cb	Cr	Cb	Cr	Cb	Cr

Improved Skip Decision (FTQ)

The skip decision has been enhanced to include an accurate AVC forward transform for skip estimation. This feature is in addition to the previous SAD or HAAR skip estimation. The results are then compared one coefficient at a time against a user-specified threshold to emulate quantization's zeroing effect. The user is returned the count of coefficients that exceeded their threshold along with a sum of the amount exceeded, both grouped at the 8x8 block level. Coefficients of similar frequencies are grouped together and will share the same threshold and are show in the matrix below. Note: the DC threshold has 16b of precision whereas the remaining thresholds are 8b. Also, only the 4x4 transform is supported.

0	1	2	3
1	2	3	4
2	3	4	5
3	4	5	6

Note: There is a performance penalty of using this feature as the throughput of SIC is reduced and hence it can be disabled entirely to save performance when necessary. However, the performance loss should not affect app performance.



HW Assisted Multi-Reference Support

VME messages will provide 4b reference identifier (refid) to the HW. VME will keep track of this field and report out the refid along with the rest of the output. For IME, this is most useful when combined with the streamin\streamout feature for multi-call as the references can now be swapped between calls and when the global record is updated, VME will keep track of which reference that shape comes from for the kernel. For the cases of SIC and FBR, this is mostly pass-through, as those messages will not change the partitioning decision from IME.

The Ref ID Cost is defined as follows. There will be two penalty costing modes: AVC and Linear. They are applied to each major shape partition independently. For the AVC costing mode, these RefIDs get the associated penalty x times per major shape partition: $0 \Rightarrow 0x$, $1-2 \Rightarrow 1x$, $3-6 \Rightarrow 2x$, $7-15 \Rightarrow 3x$. For the Linear costing mode, the penalty is applied x times per major shape partition where x is equal to the RefID value.

Shape Partition Penalty Scaling Factor by RefID

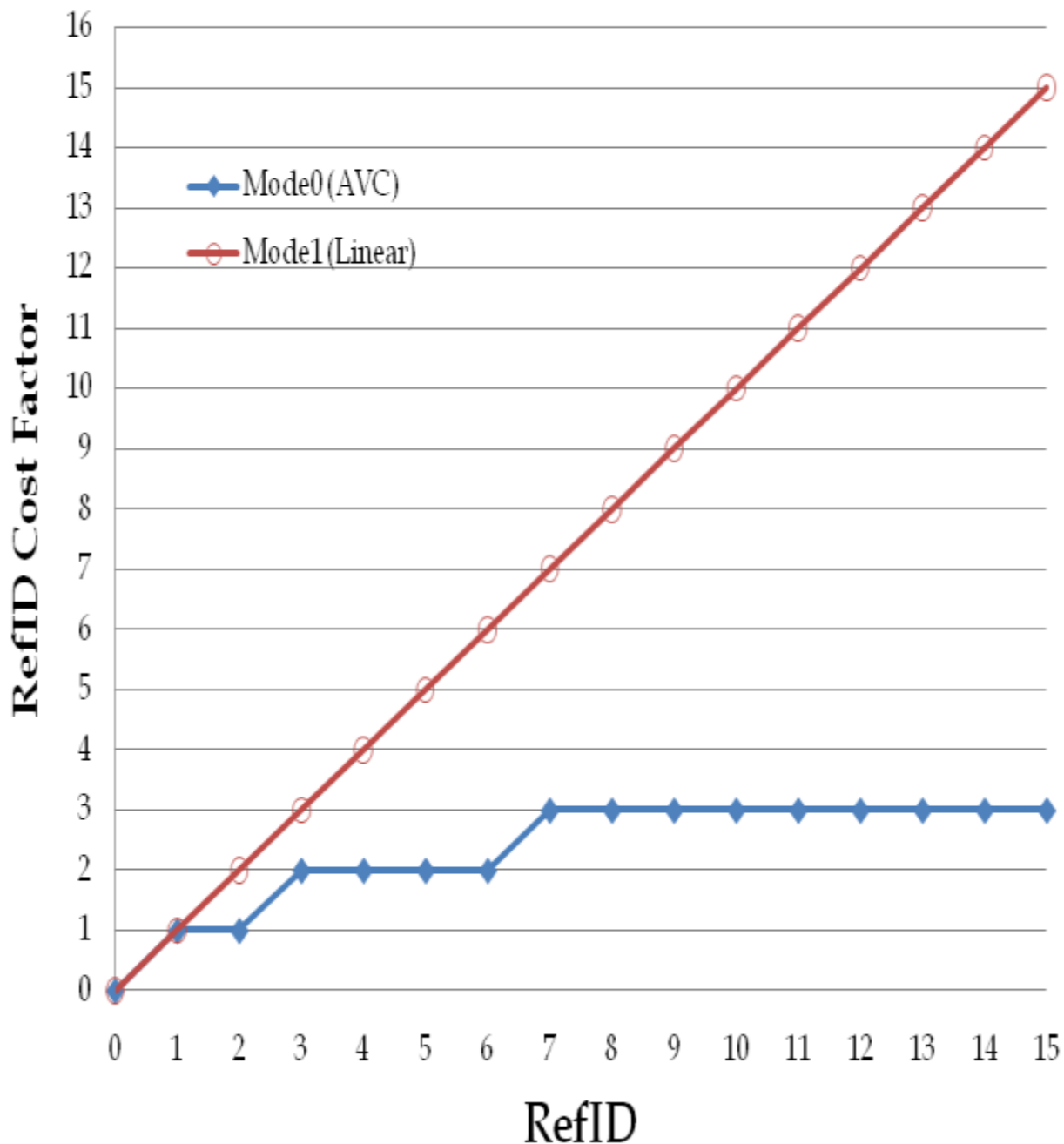

Chroma Inter Mode

In order to improve quality of complex chroma content, which is not common, VME will add *low-cost* support for performing skip, IME, FME, and BME of chroma pixels. Each VME message will be performing



either luma inter **or** chroma inter skip check, search, or refinement. Performance of chroma is not expected to be at rate with luma as the chroma pixel arrangement does not match with the uArch of the previous pipelines, so some clocks will be wasted when computes are performed illegally (these outputs are ignored, but still computed, hence performance is lost). This is the nature of the *low-cost* designation. For Chroma Inter Mode SIC messages, no intra prediction (either luma or chroma) will be performed. However, all 4 SIC message phases will be expected to be sent by the kernel. Input and output fields within the PRM will have special interpretation when chroma inter mode is enabled. Specifically, the MB source location, IME reference window location and size, skip center, and cost center input fields and the return motion vectors are to be interpreted as follows:

- All of these fields will be in context of the chroma Cb or Cr surface (e.g. nothing in relation to luma or CbCr pairs).
- This requires the HW to double the x integer component of the source, reference window location, and skip center for working with data on NV12 surfaces.
- Regarding the reference window height, the user can now select multiples of 2 instead of multiples of 4. However, the HW might overfetch what is required to simplify the design to match the luma processing mode (RefH will end up snapping to nearest larger multiple of 4 and not be lesser than 20 tall).
- The skip center and cost center will be S12.3 values. The LSB, which denotes 8th pel precision, will be ignored by the HW (only quarter pel precision is supported) for both x and y components.
- The return MVs will also be S12.3 values. Since the internal HW works on CbCr pairs instead of Y values in this mode, the integer x component of the motion vectors will need to be divided by 2 to denote the Cb motion vector. Also, both the fractional x and y components will need to be multiplied by 2 to artificially produce the 3b fractional precision result.

Increased SAD Precision

In previous generations VME would perform clamping of the MSB and drop the LSB of each 4x4 SAD\HAAR block, and impose saturation checks along the entire shape reduction tree. This was done to save HW cost, but the cost is not significant and there is a marginal risk to quality. Hence, the full SAD precision will be retained throughout the calculation and shape reduction tree. The net effect is the distortion values returned to the kernel will now be 16b instead of 14b.

Legacy Feature Removal

The IME repartition feature allows the removal of features which are no longer needed and can be emulated by the SW if required. Additionally, defining the new message types allowed for the opportunity to cleanup waste in the messages.

- Early exits
 - All of the performance thresholds (except EarlyIMESStop) are implicitly removed when the atomic message methodology is applied. Now, the kernel will check the results of each stage and determine if continued computation is required. EarlyIMESStop is still supported,



as this allows early termination of the IME searching operation, which the kernel does not have visibility into IME between SUs.

- FME Repartition
 - The cost in HW of duplicating the partitioning logic between the IME and CRE pipelines within VME is very large and outweighs the quality improvement.
- Alternate Candidate
 - The spirit of this feature can be better implemented by the atomic message types and through multiple FBR calls via the kernel per MB than what was previously achievable.
- VME State
 - The addition of a 2nd pipeline that needs access to this cache presents significant performance risk as stalls are more likely. Additionally, the search path and cost lookup tables can be added to the input message payload without significant impact to the kernel or hardware. This will eliminate the need for the IME and CRE pipes to access SVSM for VME state. An additional benefit of this is increased programmability during execution of a frame, as the kernel can now modify the search path and/or cost lookup tables on the fly and are no longer bound to fit within a limited number of locations within the lookup table. Hence, this is a faster and more flexible solution.

Software Interface – PRM Highlights

Message Structure Overview

- VME is divided into 3 message types: IME (Integer Motion Estimation), SIC (Skip & Intra Check), and FBR (Fractional & Bidirectional Refinement).
- The contents of each message are different, but they have structural similarities to reduce coding complexity.
- The first 3 input phases (*Message Phase == 1 GRF of the message payload*) are structurally the same, given the mnemonic "Universal". Individual fields within the Universal phase are ignored based on message type.
- Additional input phases are appended to each message type to fulfill the required inputs only exclusive to that message type.
- Specifically, 4 message phases are appended to SIC (SIC0-SIC3), either 2, 4 or 6 message phases (based on streamin\streamout) are appended to IME (IME0-IME5), and 4 message phases are appended to FBR (FBR0-FBR3)
- The programmer will be required to pack the necessary GRFs together to generate the correct message phase sequence prior to calling VME (i.e. 7 phases for SIC, 5, 7 or 9 phases for IME, and 7 phases for FBR).



- The return data will be structurally common amongst all 3 message types, given in 7 phases. The only exception is IME return data when streamout data is present, then 2 or 4 additional phases will be returned.
- In total, 19 message phases are based on Gen7 VME and 5 new message phases are defined for Gen7.5 VME (1 Universal Input, 1 SIC Input, 2 IME Input, 1 Output).
- Additionally, the placement of individual fields within the message phases is generally identical to that of previous generations.



IME & IDM Message Descriptor

Bits	Description
19	Header Present. If set, indicates that the message includes the header. This bit must be 1 for all VME messages. Format = Enable
18	Reserved: MBZ.
17	Reserved. Format = Enable
16	Stream-In Enable. If set, additional message phases of record stream-in are present with the input of IME message: 4 additional phases only when search control (M0.3 10:8) is 111b (dual reference & dual record) and 2 additional phases otherwise. Format = Enable
15	Stream-Out Enable. If set, additional message phases of record stream-out are present with the output of IME message: 4 additional phases only when search control (M0.3 10:8) is 111b (dual reference & dual record) and 2 additional phases otherwise. Format = Enable
14:13	Message Type 00: Reserved 01: Reserved 10: IME 11: Reserved
12:8	Reserved: MBZ
7:0	Binding Table Index. Specifies the index into the binding table for the source surface. Format = U8 Range = [0,254]



SIC and FBR Message Descriptor

Bit	Description
19	Header Present. If set, indicates that the message includes the header. This bit must be set to one for all VME messages Format = Enable
18:15	Reserved: MBZ
14:13	Message Type 00: Reserved 01: SIC 10: Reserved 11: FBR
12:8	Reserved: MBZ
7:0	Binding Table Index. Specifies the index into the binding table for the source surface. Format = U8 Range = [0,254]



Input GRFs

GRF	Name	Msgs	New	Major Contents
0	Uni0	ALL	No	Universal control data
1	Uni1	ALL	No	Universal control data
2	Uni2	ALL	Yes	Costs, FT Matrix, FBR Modes
3	SIC0	SIC	No	8 Skip MVs
4	SIC1	SIC	No	Luma intra pix, modes, masks
5	SIC2	SIC	No	Luma intra pix, modes, masks
6	SIC3	SIC	Yes	Chroma intra pix & masks
7	IME0	IME	Yes	Search Path
8	IME1	IME	Yes	Search Path
9	IME2	IME	No	Streamin/Streamout
10	IME3	IME	No	Streamin/Streamout
11	IME4	IME	No	Streamin/Streamout
12	IME5	IME	No	Streamin/Streamout
13	FBR0	FBR	No	8 Inter 4x4 MVs
14	FBR1	FBR	No	8 Inter 4x4 MVs
15	FBR2	FBR	No	8 Inter 4x4 MVs
16	FBR3	FBR	No	8 Inter 4x4 MVs

Input Message Phases by Type

VME message types require only a subset of the total GRFs of control data.

Phase	SIC	IME	FBR
0	Uni0	Uni0	Uni0
1	Uni1	Uni1	Uni1
2	Uni2	Uni2	Uni2
3	SIC0	IME0	FBR0
4	SIC1	IME1	FBR1
5	SIC2	IME2	FBR2
6	SIC3	IME3	FBR3
7		IME4	
8		IME5	

Output GRFs

GRF	Name	Msgs	New	Major Contents
-----	------	------	-----	----------------



GRF	Name	Msgs	New	Major Contents
0	Ret0	ALL	No	Best MB Control Data
1	Ret1	ALL	No	8 Inter 4x4 MVs
2	Ret2	ALL	No	8 Inter 4x4 MVs
3	Ret3	ALL	No	8 Inter 4x4 MVs
4	Ret4	ALL	No	8 Inter 4x4 MVs
5	Ret5	ALL	No	Inter Block Distortions
6	Ret6	ALL	Yes	Block Ref Indices & FTQ Data
7	IME2	IME	No	Streamin\Streamout
8	IME3	IME	No	Streamin\Streamout
9	IME4	IME	No	Streamin\Streamout
10	IME5	IME	No	Streamin\Streamout

Output Message Phases by Type

All message types return 7 phases. IME returns 2 or 4 additional phases of streamout if it is enabled (2 for uni, 4 for bi). Note the IME streamout message phases are structurally identical to the IME streamin phases.

Phase	SIC	IME	FBR
0	Ret0	Ret0	Ret0
1	Ret1	Ret1	Ret1
2	Ret2	Ret2	Ret2
3	Ret3	Ret3	Ret3
4	Ret4	Ret4	Ret4
5	Ret5	Ret5	Ret5
6	Ret6	Ret6	Ret6
7		IME2	
8		IME3	
9		IME4	
10		IME5	



Binding Table Pointers

The following gives the driver and HW perspective of how the RefID will map to the binding table pointers indices (and hence surface state). The fixed mapping simplifies the HW definition.

Progressive Content

BTI	Driver View			Universal Input M1.6 RefIDs (4b Value per Block)								Conversion
	Direction	Number	Field	FWD 0	BWD 0	FWD 1	BWD 1	FWD 2	BWD 2	FWD 3	BWD 3	BTI Equation
0	Source	N/A	N/A	N/A	N/A	N/A	N/A	N/A	N/A	N/A	N/A	= From input
1	FWD	0	N/A	0	N/A	0	N/A	0	N/A	0	N/A	= RefID * 2 + 1
2	BWD	0	N/A	N/A	0	N/A	0	N/A	0	N/A	0	= RefID * 2 + 2
3	FWD	1	N/A	1	N/A	1	N/A	1	N/A	1	N/A	= RefID * 2 + 1
4	BWD	1	N/A	N/A	1	N/A	1	N/A	1	N/A	1	= RefID * 2 + 2
5	FWD	2	N/A	2	N/A	2	N/A	2	N/A	2	N/A	= RefID * 2 + 1
6	BWD	2	N/A	N/A	2	N/A	2	N/A	2	N/A	2	= RefID * 2 + 2
7	FWD	3	N/A	3	N/A	3	N/A	3	N/A	3	N/A	= RefID * 2 + 1
8	BWD	3	N/A	N/A	3	N/A	3	N/A	3	N/A	3	= RefID * 2 + 2
9	FWD	4	N/A	4	N/A	4	N/A	4	N/A	4	N/A	= RefID * 2 + 1
10	BWD	4	N/A	N/A	4	N/A	4	N/A	4	N/A	4	= RefID * 2 + 2
11	FWD	5	N/A	5	N/A	5	N/A	5	N/A	5	N/A	= RefID * 2 + 1



BTI	Driver View			Universal Input M1.6 RefIDs (4b Value per Block)								Conversion
	Direction	Number	Field	FWD 0	BWD 0	FWD 1	BWD 1	FWD 2	BWD 2	FWD 3	BWD 3	BTI Equation
12	BWD	5	N/A	N/A	5	N/A	5	N/A	5	N/A	5	= RefID * 2 + 2
13	FWD	6	N/A	6	N/A	6	N/A	6	N/A	6	N/A	= RefID * 2 + 1
14	BWD	6	N/A	N/A	6	N/A	6	N/A	6	N/A	6	= RefID * 2 + 2
15	FWD	7	N/A	7	N/A	7	N/A	7	N/A	7	N/A	= RefID * 2 + 1
16	BWD	7	N/A	N/A	7	N/A	7	N/A	7	N/A	7	= RefID * 2 + 2
17	FWD	8	N/A	8	N/A	8	N/A	8	N/A	8	N/A	= RefID * 2 + 1
18	BWD	8	N/A	N/A	8	N/A	8	N/A	8	N/A	8	= RefID * 2 + 2
19	FWD	9	N/A	9	N/A	9	N/A	9	N/A	9	N/A	= RefID * 2 + 1
20	BWD	9	N/A	N/A	9	N/A	9	N/A	9	N/A	9	= RefID * 2 + 2
21	FWD	10	N/A	10	N/A	10	N/A	10	N/A	10	N/A	= RefID * 2 + 1
22	BWD	10	N/A	N/A	10	N/A	10	N/A	10	N/A	10	= RefID * 2 + 2
23	FWD	11	N/A	11	N/A	11	N/A	11	N/A	11	N/A	= RefID * 2 + 1
24	BWD	11	N/A	N/A	11	N/A	11	N/A	11	N/A	11	= RefID * 2 + 2
25	FWD	12	N/A	12	N/A	12	N/A	12	N/A	12	N/A	= RefID * 2



Driver View				Universal Input M1.6 RefIDs (4b Value per Block)								Conversion
BTI	Direction	Number	Field	FWD 0	BWD 0	FWD 1	BWD 1	FWD 2	BWD 2	FWD 3	BWD 3	BTI Equation
												+ 1
26	BWD	12	N/A	N/A	12	N/A	12	N/A	12	N/A	12	= RefID * 2 + 2
27	FWD	13	N/A	13	N/A	13	N/A	13	N/A	13	N/A	= RefID * 2 + 1
28	BWD	13	N/A	N/A	13	N/A	13	N/A	13	N/A	13	= RefID * 2 + 2
29	FWD	14	N/A	14	N/A	14	N/A	14	N/A	14	N/A	= RefID * 2 + 1
30	BWD	14	N/A	N/A	14	N/A	14	N/A	14	N/A	14	= RefID * 2 + 2
31	FWD	15	N/A	15	N/A	15	N/A	15	N/A	15	N/A	= RefID * 2 + 1
32	BWD	15	N/A	N/A	15	N/A	15	N/A	15	N/A	15	= RefID * 2 + 2

Interlaced Content

Driver View				Universal Input M1.6 RefIDs (4b Value per Block)								Conversion
BTI	Direction	Number	Field	FWD 0	BWD 0	FWD 1	BWD 1	FWD 2	BWD 2	FWD 3	BWD 3	BTI Equation
0	Source	N/A	N/A	N/A	N/A	N/A	N/A	N/A	N/A	N/A	N/A	= From input
1	FWD	0	Top	0	N/A	0	N/A	0	N/A	0	N/A	= RefID * 2 + 1
2	BWD	0	Top	N/A	0	N/A	0	N/A	0	N/A	0	= RefID * 2 + 2
3	FWD	0	Bot	1	N/A	1	N/A	1	N/A	1	N/A	= RefID * 2 + 1



BTI	Driver View			Universal Input M1.6 RefIDs (4b Value per Block)								Conversion
	Direction	Number	Field	FWD 0	BWD 0	FWD 1	BWD 1	FWD 2	BWD 2	FWD 3	BWD 3	BTI Equation
4	BWD	0	Bot	N/A	1	N/A	1	N/A	1	N/A	1	= RefID * 2 + 2
5	FWD	1	Top	2	N/A	2	N/A	2	N/A	2	N/A	= RefID * 2 + 1
6	BWD	1	Top	N/A	2	N/A	2	N/A	2	N/A	2	= RefID * 2 + 2
7	FWD	1	Bot	3	N/A	3	N/A	3	N/A	3	N/A	= RefID * 2 + 1
8	BWD	1	Bot	N/A	3	N/A	3	N/A	3	N/A	3	= RefID * 2 + 2
9	FWD	2	Top	4	N/A	4	N/A	4	N/A	4	N/A	= RefID * 2 + 1
10	BWD	2	Top	N/A	4	N/A	4	N/A	4	N/A	4	= RefID * 2 + 2
11	FWD	2	Bot	5	N/A	5	N/A	5	N/A	5	N/A	= RefID * 2 + 1
12	BWD	2	Bot	N/A	5	N/A	5	N/A	5	N/A	5	= RefID * 2 + 2
13	FWD	3	Top	6	N/A	6	N/A	6	N/A	6	N/A	= RefID * 2 + 1
14	BWD	3	Top	N/A	6	N/A	6	N/A	6	N/A	6	= RefID * 2 + 2
15	FWD	3	Bot	7	N/A	7	N/A	7	N/A	7	N/A	= RefID * 2 + 1
16	BWD	3	Bot	N/A	7	N/A	7	N/A	7	N/A	7	= RefID * 2 + 2
17	FWD	4	Top	8	N/A	8	N/A	8	N/A	8	N/A	= RefID * 2



	Driver View			Universal Input M1.6 RefIDs (4b Value per Block)								Conversion
BTI	Direction	Number	Field	FWD 0	BWD 0	FWD 1	BWD 1	FWD 2	BWD 2	FWD 3	BWD 3	BTI Equation
												+ 1
18	BWD	4	Top	N/A	8	N/A	8	N/A	8	N/A	8	= RefID * 2 + 2
19	FWD	4	Bot	9	N/A	9	N/A	9	N/A	9	N/A	= RefID * 2 + 1
20	BWD	4	Bot	N/A	9	N/A	9	N/A	9	N/A	9	= RefID * 2 + 2
21	FWD	5	Top	10	N/A	10	N/A	10	N/A	10	N/A	= RefID * 2 + 1
22	BWD	5	Top	N/A	10	N/A	10	N/A	10	N/A	10	= RefID * 2 + 2
23	FWD	5	Bot	11	N/A	11	N/A	11	N/A	11	N/A	= RefID * 2 + 1
24	BWD	5	Bot	N/A	11	N/A	11	N/A	11	N/A	11	= RefID * 2 + 2
25	FWD	6	Top	12	N/A	12	N/A	12	N/A	12	N/A	= RefID * 2 + 1
26	BWD	6	Top	N/A	12	N/A	12	N/A	12	N/A	12	= RefID * 2 + 2
27	FWD	6	Bot	13	N/A	13	N/A	13	N/A	13	N/A	= RefID * 2 + 1
28	BWD	6	Bot	N/A	13	N/A	13	N/A	13	N/A	13	= RefID * 2 + 2
29	FWD	7	Top	14	N/A	14	N/A	14	N/A	14	N/A	= RefID * 2 + 1
30	BWD	7	Top	N/A	14	N/A	14	N/A	14	N/A	14	= RefID * 2 + 2



BTI	Driver View			Universal Input M1.6 RefIDs (4b Value per Block)								Conversion
	Direction	Number	Field	FWD 0	BWD 0	FWD 1	BWD 1	FWD 2	BWD 2	FWD 3	BWD 3	BTI Equation
31	FWD	7	Bot	15	N/A	15	N/A	15	N/A	15	N/A	= RefID * 2 + 1
32	BWD	7	Bot	N/A	15	N/A	15	N/A	15	N/A	15	= RefID * 2 + 2

Glossary of Messages

This section describes the glossary of messages in regard to Media Sampler.

Programming Note:

- Use of any messages to the Video Motion Estimation function while there are any messages to any sampler function is not allowed.

Universal Input Message Phases

Major changes:

- Many fields are only required for one or two of the message types.
- MV cost and mode cost are moved into the message payload.
- RefID per block are new inputs.
- Enables for forward transform skip check, chroma searching.
- Thresholds and control data for forward transform skip check.
- Many of the performance thresholds have been removed (IME success, skip success, etc).

ValidMsgType = "..." identifies the given field is required for each message type. Hardware will ignore these fields under messages where that field is invalid. Hardware output for non valid fields is undefined.

DWord	Bits	Description
M0.7	31:0	
M0.6	31:0	
M0.5	31:24	<p>Reference Region Height (RefHeight)</p> <p>Reference Region Height (RefHeight): This field specifies the reference region height in pixels. When bidirectional search is enabled, this applies to both search regions. Minus 16 provides the number of search point in vertical direction.</p> <p>The value must be a multiple of 4.</p>



DWord	Bits	Description
		ValidMsgType = IME Format = U8 Range = [8, 64]
	23:16	<p>Reference Region Width (RefWidth)</p> <p>Reference Region Width (RefWidth): This field specifies the search region width in pixels. When bidirectional search is enabled, this applies to both search regions. Minus 16 provides the number of search point in horizontal direction.</p> <p>The value must be a multiple of 4.</p> <p>ValidMsgType = IME Format = U8 Range = [20, 128]</p> <p>Note: Please make sure the reference windows are not completely outside of the video frame. In that case, VME behavior is undefined.</p> <p>Note: Reference Window size must be \leq Surface Size, otherwise VME behavior is undefined.</p>
	15:8	Ignored
	7:0	<p>Dispatch ID. This ID is assigned by the fixed function unit and is a unique identifier for the thread. It is used to free up resources used by the thread upon thread completion.</p> <p>ValidMsgType = SIC, IME, FBR</p>
M0.4	31:0	Ignored (reserved for hardware delivery of binding table pointer)
M0.3	31	2D 7 by 7 Enable Reserved MBZ
	30:24	<p>Sub-Macroblock Sub-Partition Mask (SubMbPartMask)</p> <p>Sub-Macroblock Sub-Partition Mask (SubMbPartMask): This field defines the bit-mask for disabling sub-partition and sub-macroblock modes.</p> <p>The lower 4 bits are for the major partitions (sub-macroblock) and the higher 3 bits for minor partitions (with sub-partition for 4x(8x8) sub-macroblocks.</p> <p>xxxxxx1: 16x16 sub-macroblock disabled xxxxx1x: 2x(16x8) sub-macroblock within 16x16 disabled xxxx1xx: 2x(8x16) sub-macroblock within 16x16 disabled xxx1xxx: 1x(8x8) sub-partition for 4x(8x8) within 16x16 disabled</p>



DWord	Bits	Description
		xx1xxxx: 2x(8x4) sub-partition for 4x(8x8) within 16x16 disabled x1xxxxx: 2x(4x8) sub-partition for 4x(8x8) within 16x16 disabled 1xxxxxx: 4x(4x4) sub-partition for 4x(8x8) within 16x16 disabled 1111111: Invalid Note: Invalid to have all partions disabled in the IME call. ValidMsgType = IME <i>Usage note: one example usage of only enabling 4x(4x4) sub-partition while all other partitions are disabled is for video processing, whereas parallel motion searches are performed for 16 4x4 blocks. For that no further block combination (into larger sub-partitions/sub-macroblocks) is needed.</i>
	23:22	Intra SAD Measure Adjustment (IntraSAD) Intra SAD Measure Adjustment (IntraSAD): This field specifies distortion measure adjustments used for the motion search SAD comparison. This field applies to both luma and chroma intra measurement. 00b: none 01b: Reserved 10b: Haar transform adjusted 11b: Reserved ValidMsgType = SIC
	21:20	Inter SAD Measure Adjustment (InterSAD) Inter SAD Measure Adjustment (InterSAD): This field specifies distortion measure adjustments used for the motion search SAD comparison. This field applies to both luma and chroma intra measurement. 00b: none 01b: Reserved 10b: Haar transform adjusted 11b: Reserved ValidMsgType = SIC, IME, FBR, IDM
	19	Block-Based Skip Enabled: When this field is set on the skip thresholding passing criterion will be based on the maximal distortion of individual blocks (8x8's or 4x4's) instead of their sum (i.e. the distortion of 16x16). The block size is 8x8 if and only if the Transform 8x8 Flag is set to ON and the source size is 16x16. ValidMsgType = SIC



DWord	Bits	Description
	18	<p>BME disable for FBR Message (BMEDisableFBR)</p> <p>FBR messages that do not want bidirectional motion estimation performed will set this bit and VME will only perform fractional refinement on the shapes identified by subpredmode. Note: only the LSB of the subpredmode for each shape will be considered in FBR (a shape is either FWD or BWD as input of FBR, output however could change to BI if BME is enabled).</p> <p>0 = BME enabled 1 = BME disabled ValidMsgType = FBR</p>
	17	<p>Forward Transform Skip Check Enable (FTEnable)</p> <p>This field enables the forward transform calculation for skip check. It does not override the other skip calculations but it does decrease the performance marginially so don't enable it unless the transform is necessary.</p> <p>0 = FT disabled 1 = FT enabled ValidMsgType = SIC</p>
	16	<p>Process Inter Chroma Pixels Mode (InterChroaZmaMode)</p> <p>This bit switches the inter operations from luma mode to chroma mode.</p> <p>All shapes sizes are referred to as UV pairs. For instance, the 4x4 shape is a 8x4 of pixel components (16 U and 16 V, interleaved vertically) and the 8x8 shape is a 16x8 of pixel components.</p> <p>MBMode is always 8x8.</p> <p>MBSubShape is either 8x8 or 4x4 indicated by LSB[1:0]. Bits[7:2] are MBZ.</p> <p>For MBSubShape of 4x4, SubPredMode is mapped to each 4x4 shape.</p> <p>Only 8x8 and 4x4 ModeCost are valid.</p> <p>Source block size is ignored.</p> <p>Streamin\streamout distortions are overloaded on 16x16 (Chroma8x8) and 8x8 (Chroma4x4).</p> <p>BilinearEnable is ignored (Chroma can only perform bilinear filtering)</p> <p>Restrictions when set: Intra operations are disabled (SIC), valid ref window sizes are 32x20, 24x24 (max Xsus), 16x32 (max Xsus), and 10x20 (max Xsus) (IME), adaptive is disabled (IME), no backward penalty cost (ALL), and only 4x4 and 8x8 shapes are valid (ALL).</p> <p>ValidMsgType = SIC, IME, FBR</p>
	15	<p>Disable Field Cache Allocation</p> <p>This field, when set to 1, disables the optimized field cache line method in the Sampler Cache for</p>



DWord	Bits	Description
		reference block data when RefAccess is 1 (field based). It is ignored by hardware if RefAccess is 0. 0 – frame or field cache lines according to RefAccess 1 – always frame cache lines
	14	<p>Skip Mode Type</p> <p>For B_DIRECT_16x16, both motion vectors of the skip center pair 0 are used.</p> <p>For B_DIRECT_8x8s, all four skip center pairs are fully used (VME will never try to combine them with non-skip shapes from IME, FME, or BME).</p> <p>0: SKIP_1MVP – one MV pair for 16x16</p> <p>1: SKIP_4MVP – Four MV pairs for 8x8s (in this case and only this case, SkipCenter Delta 1-3 will be used)</p> <p>Note: SkipModeType should be programmed to 1MVP for non-16x16 Source size.</p> <p>ValidMsgType = SIC</p>
	13:12	<p>Sub-Pel Mode (SubPelMode)</p> <p>This field defines the half/quarter pel modes. The mode is inclusive, ie., higher precision mode samples lower precision locations.</p> <p>00b: integer mode searching</p> <p>01b: half-pel mode searching</p> <p>10b: Reserved</p> <p>11b: quarter-pel mode searching</p> <p>ValidMsgType = FBR</p>
	11	<p>Dual Search Path Option</p> <p>Used only for dual record cases, this field flags whether two searching records uses the same or the different paths.</p> <p>0: use the same path as specified by the Search Path Location array</p> <p>1: use the different paths, the first one uses the even entries of the Search Path Location array and the second one uses the odd entries of the Search Path Location array.</p> <p>ValidMsgType = IME</p>
	10:8	<p>Search Control (SearchCtrl)</p> <p>This field specifies how the motion search is performed.</p> <p>ValidMsgType = IME</p> <p>The following table shows the valid encodings. Other encodings are reserved.</p>



DWord	Bits	Description	
		Code	Mode
		000b	<p>Single reference, single record and single start.</p> <p>Search is performed only on reference 0; only cost center 0 and start 0 are used. There is only one record. Adaptive search is also allowed. However, when AdaptiveEn is on, LenSU must be at least 2 as the adaptive search in VME is one-step delayed.</p> <p>This is the common single directional motion search mode.</p>
		001b	<p>Single reference, single record and dual start.</p> <p>Search is performed only on reference 0; only cost center 0 is used. There is only one record. Search performs first on start 0 and then on start 1. Then if LenSP is not reached, the predetermined search path will start on start 1 with increment added to start 1 location. It then is followed by adaptive search.</p> <p>This is used for single direction adaptive search.</p>
		011b	<p>Single reference, dual record (and implied dual start).</p> <p>Search is performed only on reference 0; both cost center 0 and 1 and start 0 and 1 are used. Two records are used for both paths during IME.</p> <p>When integer search is complete, the two records are combined to find the best search. Sub-pel refinement is only performed from the best one.</p> <p>This may be used for search for multiple motion search candidates/predicators.</p>
		111b	<p>Dual reference, dual record (and implied dual start).</p> <p>Search is performed on references 0/1 with both cost centers 0/1 and starts 0/1. Two records are used for both paths during IME.</p> <p>When integer search is complete, and then sub-pel refinement is also performed separately, the two records are combined to find the best search on a subblock basis.</p> <p>This may be used for bidirectional motion search, or multi-reference P search. Whether bidirectional is enabled or not depends on the bidirection sub-macroblock mask.</p> <p>If BiSubMbPartMask is set to 1111'b, bidirectional search is disabled. VME will output only the best unidirectional search results. Otherwise, BME will be performed.</p> <p>Note that bidirectional search and sub-pel refinement are orthogonal features that can be enabled independently.</p>
	7	<p>Reference Access (RefAccess)</p> <p>This field defines how the reference blocks are accessed from the reference frames. It indicates if the source picture is a frame picture or a field picture.</p> <p><i>Programming Note: For all known video coding standards, reference pictures always have the same picture type as the source picture. Therefore, this field should be programmed to be the same as</i></p>	



DWord	Bits	Description
		<p>SrcAccess.</p> <p>0: frame based 1: field based</p>
	6	<p>Source Access (SrcAccess)</p> <p>This field defines how the source block is accessed from the source frame. It indicates if the source picture is a frame picture or a field picture. It is similar to the Picture Type used in video standards.</p> <p>0: frame based 1: field based</p>
	5:4	<p>Inter MbType Remap (MbTypeRemap): This field controls the mapping of the output MbType when the VME output is an Inter (IntraMbFlag = INTER). The intended usage, for example, is for two forward (or backward) references or for two search regions from the same reference picture in one VME call. Hardware ignores this field if the VME output is an intra type (IntraMbFlag = INTRA).</p> <p>00b: no remapping</p> <p>01b: remapping MbType to forward only (1-3 mapped to 1, even numbers in [4-14h] mapped to 4, odd numbers in [5-15h] mapped to 5, and 16h is unchanged)</p> <p>10b: remapping MbType to backward only (1-3 mapped to 2, even numbers in [4-14h] mapped to 6, odd numbers in [5-15h] mapped to 7, and 16h is unchanged)</p> <p>11b: Reserved</p> <p>ValidMsgType = IME, FBR</p>
	3	<p>Reserved: MBZ</p> <p>(</p> <p>Note: The following text needs to be maintained so that we can bring back the feature in the next opportunity.</p> <p>Will be used for Field 8x8 Enabled: This field enables 8x8 interlaced-block partitioning (used for VC-1).</p> <p>Note: Enabling Field 8x8 prevents use of subpartitions types 4x4, 4x8 and 8x4, RefAccess and SrcAccess must be 0 and SrcSize must be 16x16 (00). Field8x8 and Field16x8 are mutually exclusive.</p> <p>)</p>
	2	<p>Reserved: MBZ</p> <p>(</p> <p>Note: The following text needs to be maintained so that we can bring back the feature in the next opportunity.</p>



DWord	Bits	Description
		<p>Will be used for Field 16x8 Enabled: This field enables 16x8 interlaced-block partitioning for MPEG-2.</p> <p>Note: Enabling Field 16x8 prevents use of subpartitions types 8x16, 4x4, 4x8 and 8x4, RefAccess and SrcAccess must be 0 and SrcSize must be 16x16 (00). Field8x8 and Field16x8 are mutually exclusive.</p> <p>)</p>
	1:0	<p>Source Block Size (SrcSize)</p> <p>This field defines how the 16x16 source block is formed. When Source Block Size is less than 16x16, SU larger than 4x4 will be used.</p> <p>00b: 16x16 01b: 16x8 10b: Reserved (for 8x16) 11b: 8x8</p> <p>ValidMsgType = SIC, IME, FBR</p>
M0.2	31:16	<p>Source Y (SrcY)</p> <p>This field defines the vertical position (of the block's upper-left pixel) in units of pixels for the source block in the source frame.</p> <p>The resulting Y address in the reference picture must be in even line aligned within the reference picture. Specifically, if the reference picture is a frame picture. the resulting Y address must be 2-line aligned; if the reference picture is a field picture within a frame storage, and the resulting Y address must be 2-line aligned within the field. i.e. it must be an even number for the frame case, and must be equal to 0 or 1 modulo 4 for the field case.</p>
	15:0	<p>Source X (SrcX)</p> <p>This field defines the horizontal position (of the block's upper-left pixel) in units of pixels for the source block in the source picture.</p> <p>The source block must be within the source picture starting at any integer grid.</p> <p>For SIC messages where Intra Compute Type is set to 00 (Luma + Chroma enabled), SrcX must be a multiple of 2.</p>
M0.1	31:16	<p>Reference 1 Y Delta (Ref1Y)</p> <p>This field defines the vertical position (of the upper-left corner of the reference region) in units of pixels for Reference 1 region relative to the surface origin. The resulting Y address in the reference picture must be in even line aligned within the reference picture. Specifically, if the reference picture is a frame picture. the resulting Y address must be 2-line aligned; if the reference picture is a field picture within a frame storage, and the resulting Y address must be 2-line aligned within the field. I.e. it must be an even number for the frame case, and must be equal to 0 or 1 modulo 4 for the</p>



DWord	Bits	Description
		field case. Note: For search control=3, this must equal Ref0Y.
	15:0	Reference 1 X Delta (Ref1X) This field defines the horizontal position (of the upper-left corner of the reference region) in units of pixels for Reference 1 region relative to the surface origin. The resulting reference region is allowed to be outside the picture. Pixel replication is applied to generate out of bound reference pixels. This field is only valid when dual reference mode is selected. Note: For search control=3, this must equal Ref0X. ValidMsgType = IME Format = S15 Hardware Range: [-2048 to 2047]
M0.0	31:16	Reference 0 Y Delta (Ref0Y) This field defines the vertical position (of the upper-left corner of the reference region) in units of pixels for Reference 0 region relative to the surface origin. [HSW]: The resulting Y address in the reference picture must be in even line aligned within the reference picture. Specifically, if the reference picture is a frame picture, the resulting Y address must be 2-line aligned; if the reference picture is a field picture within a frame storage, and the resulting Y address must be 2-line aligned within the field. i.e. it must be an even number for the frame case, and must be equal to 0 or 1 modulo 4 for the field case.
	15:0	Reference 0 X Delta (Ref0X) This field defines the horizontal position (of the upper-left corner of the reference region) in units of pixels for Reference 0 region relative to the surface origin. The resulting reference region is allowed to be outside the picture. Pixel replication is applied to generate out of bound reference pixels.
M1.7	31:24	Skip Center Enable Mask (SkipCenterMask): [bit 31...24] xxxx xxx1: Ref0 Skip Center 0 is enabled [corresponds to M2.0] xxxx xx1x: Ref1 Skip Center 0 is enabled [corresponds to M2.1] xxxx x1xx: Ref0 Skip Center 1 is enabled [corresponds to M2.2] xxxx 1xxx: Ref1 Skip Center 1 is enabled [corresponds to M2.3]



DWord	Bits	Description
		xxx1 xxxx: Ref0 Skip Center 2 is enabled [corresponds to M2.4] xx1x xxxx: Ref1 Skip Center 2 is enabled [corresponds to M2.5] x1xx xxxx: Ref0 Skip Center 3 is enabled [corresponds to M2.6] 1xxx xxxx: Ref1 Skip Center 3 is enabled [corresponds to M2.7] Illegal cases: Disable both Ref0 and Ref1 Skip Center 0 in case of Skip_1MVP. Disable both Ref0 and Ref1 for any Skip Center pair in case of Skip_4MVP. ValidMsgType = SIC ValidMsgType = SIC
	23	IDM Shape Mode Select (IDMShapeMode): [Also see M1.1 bits 30 and 31] [HSW]: Reserved MBZ Notes: <ul style="list-style-type: none"> Only ref window size of 32x32 (shape16x16), 24x24(shape8x8), 128x16 (shape16x16), and 32x16 (shape16x16) are supported. Search control[2:0] will be default to single ref and single start. Luma only.
	22	RefID Cost Mode Select (RefIDCostMode) Selects the RefID costing mode. 0 = Mode0 (AVC) 1 = Mode1 (linear)
	21	Enable AC-Only HAAR (ACOnlyHAAR) This bit zeros out the DC component in the HAAR SATD block. 0 = AC+DC HAAR 1 = AC HAAR ValidMsgType = SIC, IME, FBR
	20	Enable Weighted-SAD\HAAR (WeightedSADHAAR) This bit enables fixed weighted SAD\HAAR pattern. Right-shift 4x4 SAD\HAAR for the sub-blocks mapped onto the 16x16 source macroblock by the following amounts: 2 1 1 2 1 0 0 1



DWord	Bits	Description		
		<p>1 0 0 1</p> <p>2 1 1 2</p> <p>0 = Flat weighting</p> <p>1 = Enable Weighted-SAD\HAAR</p> <p>Only supported for source-type luma 16x16. Streamin\Streamout must be disabled.</p> <p>ValidMsgType = IME</p>		
	19	<p>Source Field Polarity Select (SrcFieldPolarity)</p> <p>If SrcAccess = 1 (M0.3-6), meaning field based, than the hardware requires this value is to derive the correct location on the source surface in memory to fetch pixels. This is because the source is stored as a frame picture with both fields interleaved in memory and the SrcY value (M0.2-31:16) is the location on the field picture (in other words, it does not convey the field polarity).</p> <p>Hence, the starting y-pixel coordinate that will be fetched from the memory will be:</p> $\text{SrcY} * 2 + \text{SrcFieldPolarity}$ <p>Else, this field is ignored by the hardware.</p>		
	18	<p>Bilinear Filter Enable (BilinearEnable)</p> <p>If set, the fractional filter will implement a simple bilinear interpolation filter instead of the 4-tap filter. Note: this is supported for both hpel and qpel interpolation.</p> <p>ValidMsgType = SIC, FBR</p> <p>Format = Enable</p>		
	17:16	<p>MV Cost Scaling Factor (MVCostScaleFactor)</p> <p>This term allows the user to redefine the precision of the lookup into the LUT_MV based on the MV cost difference from the cost center. The piecewise linear cost function is defined from 0 to 64 in powers of 2 intervals, and the precision of the difference is set by this field. There are 4 precision choices:</p> <p>00b: qpel [Qpel difference between MV and cost center: eff cost range 0-15pel]</p> <p>01b: hpel [Hpel difference between MV and cost center: eff cost range 0-31pel]</p> <p>10b: pel [Pel difference between MV and cost center: eff cost range 0-63pel]</p> <p>11b: 2pel [2Pel difference between MV and cost center: eff cost range 0-127pel]</p>		
	15:8	<p>Macroblock Intra Structure (MbIntraStruct): This is a bitmask that specifies neighbor macroblock availability. This allows software to constrain intra prediction mode search.</p> <p>Note: user must set Bit6=Bit5.</p> <table border="1" data-bbox="324 1864 1370 1911"> <tr> <td>Bits</td> <td>MotionVerticalFieldSelect Index</td> </tr> </table>	Bits	MotionVerticalFieldSelect Index
Bits	MotionVerticalFieldSelect Index			



DWord	Bits	Description														
		<table border="1"> <tr> <td>7</td> <td>Reserved: MBZ (for IntraPredAvailFlagF – F (pixel[-1,7] available for MbAff)</td> </tr> <tr> <td>6</td> <td>Reserved: MBZ (for IntraPredAvailFlagA/E – A (left neighbor top half for MbAff)</td> </tr> <tr> <td>5</td> <td>IntraPredAvailFlagE/A – A (Left neighbor or Left bottom half)</td> </tr> <tr> <td>4</td> <td>IntraPredAvailFlagB – B (Upper neighbor)</td> </tr> <tr> <td>3</td> <td>IntraPredAvailFlagC – C (Upper left neighbor)</td> </tr> <tr> <td>2</td> <td>IntraPredAvailFlagD – D (Upper right neighbor)</td> </tr> <tr> <td>1:0</td> <td>Reserved: MBZ (ChromaIntraPredMode)</td> </tr> </table> <p>ValidMsgType = SIC</p>	7	Reserved: MBZ (for IntraPredAvailFlagF – F (pixel[-1,7] available for MbAff)	6	Reserved: MBZ (for IntraPredAvailFlagA/E – A (left neighbor top half for MbAff)	5	IntraPredAvailFlagE/A – A (Left neighbor or Left bottom half)	4	IntraPredAvailFlagB – B (Upper neighbor)	3	IntraPredAvailFlagC – C (Upper left neighbor)	2	IntraPredAvailFlagD – D (Upper right neighbor)	1:0	Reserved: MBZ (ChromaIntraPredMode)
7	Reserved: MBZ (for IntraPredAvailFlagF – F (pixel[-1,7] available for MbAff)															
6	Reserved: MBZ (for IntraPredAvailFlagA/E – A (left neighbor top half for MbAff)															
5	IntraPredAvailFlagE/A – A (Left neighbor or Left bottom half)															
4	IntraPredAvailFlagB – B (Upper neighbor)															
3	IntraPredAvailFlagC – C (Upper left neighbor)															
2	IntraPredAvailFlagD – D (Upper right neighbor)															
1:0	Reserved: MBZ (ChromaIntraPredMode)															
	7	<p>Luma Intra Source Corner Swap (IntraCornerSwap):This field specifies the format of the intra luma neighbor pixel format in the message.</p> <p>0: top neighbors are in sequential order</p> <p>1: Left-top corner is swapped with the last left-edge neighbor</p> <p>ValidMsgType = SIC</p>														
	6	<p>Non Skip MB Mode Cost Added (NonSkipModeAdded)</p> <p>This field indicates that the distortion of the survived motion vectors will become non-skip, and the MB mode cost will be added to its distortion.</p> <p>ValidMsgType = SIC</p>														
	5	<p>Non Skip Zero MV Cost Added (NonSkipZMvAdded)</p> <p>This field indicates that the distortion of the survived motion vectors will become non-skip, and the zero MV component costs will be added to its distortion.</p> <p>ValidMsgType = SIC</p>														
	4:0	<p>Luma Intra Partition Mask (IntraPartMask)</p> <p>This field specifies which Luma Intra partition is enabled/disabled for intra mode decision.</p> <p>xxxx1: luma_intra_16x16 disabled</p> <p>xxx1x: luma_intra_8x8 disabled</p> <p>xx1xx: luma_intra_4x4 disabled</p>														



DWord	Bits	Description
		Note: for SIC message with IntraComputeType == 00 or 01, at least 1 partition must be enabled. Bits [4:3] MBZ ValidMsgType = SIC
M1.6	31:28	Bwd Block 3 RefID
	27:24	Fwd Block 3 RefID
	23:20	Bwd Block 2 RefID
	19:16	Fwd Block 2 RefID
	15:12	Bwd Block 1 RefID
	11:8	Fwd Block 1 RefID
	7:4	Bwd Block 0 RefID
	3:0	<p>Fwd Block 0 RefID</p> <p>M1.6 contains 8 input RefIDs, 1 per block. The RefID is used to penalize selection of shapes away from the optimal RefID similar to how MVCost penalizes shapes with motion vectors far from the cost center.</p> <p>The following restriction is for [HSW] only: For field content, the top fields must have bit 0 as 0 and bottom fields must have bit 0 as 1.</p> <p>RefIDs are programmed similar to SubPredMode:</p> <p>MbMode 16x16: RefID0</p> <p>MbMode 16x8: RefID0 Top\RefID1 Bottom</p> <p>MbMode 8x16: RefID0 Left\RefID1 Right</p> <p>MbMode 8x8: RefID 0,1,2,3 mapped to 8x8 block number.</p> <p>Performance note: For cases when not MbMode 8x8 and all major shapes share the same reference ID, SW should copy the RefID value into all 4 blocks for surface state fetching optimization.</p>
M1.5	31:16	<p>Cost Center 1 Delta Y (CostCenter0Y)</p> <p>This field defines the Y value for the second cost center (associated with the second start) relative to the picture source MB Y value.</p> <p>For FBR messages, Cost Center 1 is used for all backward shapes.</p> <p>ValidMsgType = SIC, IME, FBR</p> <p>Format = S13.2 (2's comp)</p> <p>Hardware Range: [-512.00 to 511.75]</p>
	15:0	<p>Cost Center 1 Delta X (CostCenter1X)</p> <p>This field defines the X value for the second cost center (associated with the second start) relative to the picture source MB X value.</p>



DWord	Bits	Description
		<p>For FBR messages, Cost Center 1 is used for all backward shapes.</p> <p>ValidMsgType = SIC, IME, FBR</p> <p>Format = S13.2 (2's comp)</p> <p>Hardware Range: [-2048.00 to 2047.75]</p>
M1.4	31:16	<p>Cost Center 0 Delta Y (CostCenter0Y):</p> <p>This field defines the Y value for the first cost center (associated with the first start) relative to the picture source MB Y value.</p> <p>For FBR messages, Cost Center 0 is used for all forward shapes.</p> <p>ValidMsgType = SIC, IME, FBR</p> <p>Format = S13.2 (2's comp)</p> <p>Hardware Range: [-512.00 to 511.75]</p>
	15:0	<p>Cost Center 0 Delta X (CostCenter0X):</p> <p>This field defines the X value for the first cost center (associated with the first start) relative to the picture source MB X value.</p> <p>For FBR messages, Cost Center 0 is used for all forward shapes.</p> <p>ValidMsgType = SIC, IME, FBR</p> <p>Format = S13.2 (2's comp)</p> <p>Hardware Range: [-2048.00 to 2047.75]</p>
M1.3	31:30	Weighted SAD Control Sub-block 15 (F)
	29:28	Weighted SAD Control Sub-block 14 (E)
	27:26	Weighted SAD Control Sub-block 13 (D)
	25:24	Weighted SAD Control Sub-block 12 (C)
	23:22	Weighted SAD Control Sub-block 11 (B)
	21:20	Weighted SAD Control Sub-block 10 (A)
	19:18	Weighted SAD Control Sub-block 9
	17:16	Weighted SAD Control Sub-block 8
	15:14	Weighted SAD Control Sub-block 7
	13:12	Weighted SAD Control Sub-block 6
	11:10	Weighted SAD Control Sub-block 5
	9:8	Weighted SAD Control Sub-block 4
	7:6	Weighted SAD Control Sub-block 3
5:4	Weighted SAD Control Sub-block 2	
3:2	Weighted SAD Control Sub-block 1	



DWord	Bits	Description
	1:0	Weighted SAD Control Sub-block 0 M1.3 31:0 Reserved MBZ.
M1.2	31:28	Start Center 1 Y (Start1Y) This field defines the Y position of Search Path 1 relative to the reference Y location. It is in units of SU. ValidMsgType = IME Format = U4
	27:24	Start Center 1 (Start1X) This field defines the X position of Search Path 1 relative to the reference X location. It is in units of SU. The corresponding reference block must be fully within the reference region. ValidMsgType = IME Format = U4
	23:20	Start Center 0 Y (Start0Y) This field defines the Y position of Search Path 1 relative to the reference Y location. It is in units of SU. ValidMsgType = IME Format = U4
	19:16	Start Center 0 X (Start0X) This field defines the X position of Search Path 1 relative to the reference X location. It is in units of SU. The corresponding reference block must be fully within the reference region. ValidMsgType = IME Format = U4
	15:8	Maximum Search Path Length (MaxNumSU) This field defines the maximum number of SUs per reference including the predetermined SUs and the adaptively generated SUs. Note: Every SU in fixed path will be counted (including the out-bound ones and repeated ones), and in addition for adaptive SUs only the ones actually searched will be added. ValidMsgType = IME



DWord	Bits	Description
		Format = U8, with valid range of [1,63]
	7:0	<p>Max Fixed Search Path Length (LenSP)</p> <p>This field defines the maximum number of SUs per reference which are evaluated by the predetermined SUs. When adaptive walk is enabled, adaptive walk starts when this number is reached.</p> <p>Note: Every SU in fixed path will be counted (including the out-bound ones and repeated ones).</p> <p>ValidMsgType = IME</p> <p>Format = U8, with valid range of [1,63]</p>
M1.1	31	<p>IDM Shape Mode Select (IDMShapeMode) Extension</p> <p>[HSW]: Reserved MBZ.</p>
	30	<p>IDM Shape Mode Select (IDMShapeMode) Extension</p> <p>Reserved MBZ.</p>
	29	<p>Ref pixel bias enable</p>
	28	<p>Unidirectional Mix Disable (UniMixDisable): if it is on, all unidirectional resulting motion vectors must share the same direction, <i>i.e.</i> either all are forward, or all are backward. If this field is off, each partition, down to 8x8 subblock, may have a different mix of forward and backward motion vectors. (Within each 8x8 subblock, only one common choice is allowed.)</p> <p>Programmers note: for the case when BMEdisableFBR is set, only the input subpredmode direction will be refined. If BMEdisableFBR is not set, both directions undergo fractional refinement prior to bidirectional refinement, but the subpredmode output will never invert directions if the refinement yielded a better result (subpredmode could change to bidirectional in this case though).</p> <p>This field is MBZ except for cases of Search Control = 111'b (e.g. 7, dual reference).</p> <p>ValidMsgType = IME</p>
	27:24	<p>Reserved: MBZ</p>
	23:22	<p>Reserved: MBZ</p>
	21:16	<p>Bidirectional Weight (BiWeight)</p> <p>This field defines the weighting for the backward and forward terms to generate the bidirectional term. This field is only valid for bidirectional search (SearchCtrl = 111).</p> <p>ValidMsgType = SIC, FBR</p> <p>Format = U6</p>



DWord	Bits	Description
		Valid Values: [16, 21, 32, 43, 48]
	15:8	<p>RefId Polarity Bits</p> <p>Bit15->bwd block3 Bit14->bwd block2 Bit13->bwd block1 Bit12->bwd block0 Bit11->fwd block3 Bit10->fwd block2 Bit9->fwd block1 Bit8->fwd block0</p>
	7	Reserved: MBZ
	6	<p>Extended MV Cost Range</p> <p>This bit specifies if the increased 12-bit mvcost range is used vs. the legacy 10-bit range.</p> <p>0 = Disable 1 = Enable</p> <p>ValidMsgType = SIC,IME, FBR</p>
	5:0	<p>Maximum Number of Motion Vectors (MaxNumMVs)</p> <p>This field specifies the maximum number of motion vectors allowed for the current macroblock. This field affects the macroblock partition decision. VME will return the best partition with MvQuantity not exceeding MaxNumMVs. MaxNumMVs = 0 will only allow skip as a valid Inter mode.</p> <p>Note: This value is used ONLY for 16x16 source MB mode.</p> <p>Usage Example: <i>Certain profiles/levels for AVC standard have restriction for the maximum number of motion vectors allowed for two consecutive macroblocks (MaxMvsPer2Mb may be 16 or 32).</i></p> <p>ValidMsgType = IME Format = U6</p>
M1.0	31:24	<p>Early IME Successful Stop Threshold (EarlyImeStop)</p> <p>This field specifies the threshold value for the IME distortion computes of single 16x16 mode below which no more search will be performed within the IME unit.</p> <p>This field only takes effect if EarlyImeSuccessEn is set.</p>



DWord	Bits	Description
		<p>Note: Early IME exit only looks at ref0, and uses 8x8 for source 8x8 and 2 16x8 0 for source 16x8.</p> <p>ValidMsgType = IME</p> <p>Format = U4U4 (encoded value should fit in 14-bits)</p>
	23:16	Reserved: MBZ
	15:8	Reserved:MBZ
	7	<p>Transform 8x8 Flag For Inter Enable (T8x8FlagForInterEn)</p> <p>This field specifies whether Transform8x8Flag is updated for inter mode according the resulting inter-mode sub-partition size.</p> <p>0: disable</p> <p>1: enable</p> <p>ValidMsgType = SIC, IME, FBR</p>
	6	<p>X only search</p> <p>This field enables searching in only the x dimension.</p> <p>ValidMsg type - IME, IDM</p>
	5	<p>Early IME Success Enable (EarlyImeSuccessEn)</p> <p>This field specifies whether the Early Success may terminate on full-pel precision. When this field is not set, if early out does occur on full-pel location, hardware continues to local sub-pel refinement search and so on. When this field is set, however, the local sub-pel refinement step is skipped and intra search is also skipped.</p> <p>This field only takes effect if EarlySuccessEn is set.</p> <p><i>Usage example: This may be used for cases with large static area where (0,0) motion vector delivers very good results that no FME refinement is needed and also intra check is also skipped. This may also be used in place of Skip Mode Checking when the skip center(s) happens to be an integer location inside the SU of the Start Center(s).</i></p> <p>0: disable</p> <p>1: enable</p> <p>ValidMsgType = IME</p>
	4:3	Reserved: MBZ
	2	<p>Bidirectional Mix Disable (BiMixDis): if it is on, all resulting motion vectors must share the same direction, <i>i.e.</i> either all are unidirectional (<i>i.e.</i> forward or backward), or all bidirectional. If this field is off, each partition may have different search direction (forward, backward or bidirectional).</p>



DWord	Bits	Description
		<p>Usage Example: MPEG2 bidirectional decision is at whole macroblock level, while AVC decision is at subblock level.</p> <p>0: bidirectional decision on subblock level that bidirectional mode is enabled</p> <p>1: bidirectional decision on whole macroblock</p> <p>Note: This must be disabled for SubMbShape with any minors (8x4/4x8/4x4) in the MB.</p> <p>ValidMsgType = FBR</p>
	1	<p>Adaptive Search Enable (AdaptiveEn): This field defines whether adaptive searching is enabled for IME. When Adaptive Search is enabled, there must be at least two search steps preceded. It is either from a single start with step of ≥ 2 or from a dual-start.</p> <p>0: disable</p> <p>1: enable</p> <p>ValidMsgType = IME</p>
	0	<p>Skip Mode Enable (SkipModeEn): This field specifies whether the skip mode checking is performed before the motion search. If this field is set, Skip Center, which may have a sub-pel precision, is first tested before IME.</p> <p>0: disable</p> <p>1: enable</p>
M2.7	31:24	SIC Forward Transform Coeff Threshold Matrix[6] - Highest Freq
	23:16	SIC Forward Transform Coeff Threshold Matrix[5]
	15:8	SIC Forward Transform Coeff Threshold Matrix[4]
	7:0	SIC Forward Transform Coeff Threshold Matrix[3]
M2.6	31:24	SIC Forward Transform Coeff Threshold Matrix[2]
	23:16	SIC Forward Transform Coeff Threshold Matrix[1]
	15:0	<p>SIC Forward Transform Coeff Threshold Matrix[0]</p> <p>Values of the threshold matrix[0..6] are provided here.</p> <p>Matrix[0] contains the DC threshold for the Forward Transform Skip check. It has increased precision vs. the other thresholds due to the larger size of DC coefficients. Matrix[1] through Matrix[6] have lower precision.</p> <p>Threshold Matrix for 4x4 transform is as follows:</p> <pre> 0 1 2 3 1 2 3 4 2 3 4 5 3 4 5 6 </pre>



DWord	Bits	Description
		Matrix[0] Format = U16 Matrix[1..6] Format = U8 ValidMsgType = SIC
M2.5	31:24	Reserved: MBZ
	23:16	FBR SubPredMode Input VME will use this to select the appropriate shapes from the input message to perform FME on. Bits [1:0]: SubMbPredMode[0] Bits [3:2]: SubMbPredMode[1] Bits [5:4]: SubMbPredMode[2] Bits [7:6]: SubMbPredMode[3] 00: Forward 01: Backward 10: Bidirectional 11: Illegal Note: only the LSB of the subpredmode for each shape will be considered in FBR (a shape is either FWD or BWD as input of FBR). ValidMsgType = FBR
	15:8	FBR SubMBSShape Input This field is used to specify the subshape per block for fractional and bidirectional refinement. Bits [1:0]: SubMbShape[0] Bits [3:2]: SubMbShape[1] Bits [5:4]: SubMbShape[2] Bits [7:6]: SubMbShape[3] 00: 8x8 01: 8x4 10: 4x8 11: 4x4 ValidMsgType = FBR
	7:2	Reserved: MBZ



DWord	Bits	Description
	1:0	<p>FBR MbMode Input</p> <p>This field is used to specify the inter macroblock type in the same format as VME output.</p> <p>00: 16x16</p> <p>01: 16x8</p> <p>10: 8x16</p> <p>11: 8x8</p> <p>ValidMsgType = FBR</p>
M2.4	31:24	MV 7 Cost
	23:16	MV 6 Cost
	15:8	MV 5 Cost
	7:0	MV 4 Cost
M2.3	31:24	MV 3 Cost
	23:16	MV 2 Cost
	15:8	MV 1 Cost
	7:0	<p>MV 0 Cost</p> <p>Motion vector costings. See 6.3.3.1 for details. In short, the cost is linearly interpolated between control points.</p> <p>Format = U4U4 (encoded value must fit in 10-bits)</p>
M2.2	31:24	<p>Chroma Intra Mode Cost</p> <p>Penalty for chroma intra modes.</p> <p>DC = 0x</p> <p>Horz = 1x</p> <p>Vert = 1x</p> <p>Plane = 2x</p> <p>Format = U4U4 (encoded value must fit in 12-bits)</p> <p>ValidMsgType = SIC, IME, FBR</p>
	23:16	<p>RefID Cost</p> <p>RefID costing base penalty. Under AVC or Linear mode, different scaling are applied on top of this.</p> <p>Format = U4U4 (encoded value must fit in 12-bits)</p>
	15:8	Mode 9 Cost



DWord	Bits	Description
		MODE_INTER_BWD Format = U4U4 (encoded value must fit in 12-bits) ValidMsgType = SIC, IME, FBR
	7:0	Mode 8 Cost MODE_INTER_16x16 Format = U4U4 (encoded value must fit in 12-bits)
M2.1	31:24	Mode 7 Cost MODE_INTER_4x4q MODE_INTER_FIELD_8x8q Format = U4U4 (encoded value must fit in 10-bits) ValidMsgType = SIC, IME, FBR
	23:16	Mode 6 Cost MODE_INTER_8x4q MODE_INTER_4x8q MODE_INTER_FIELD_16x8 Format = U4U4 (encoded value must fit in 10-bits) ValidMsgType = SIC, IME, FBR
	15:8	Mode 5 Cost MODE_INTER_8x8q Format = U4U4 (encoded value must fit in 10-bits)
	7:0	Mode 4 Cost MODE_INTER_16x8 MODE_INTER_8x16 Format = U4U4 (encoded value must fit in 12-bits) ValidMsgType = SIC, IME, FBR
M2.0	31:24	Mode 3 Cost MODE_INTRA_4x4 Format = U4U4 (encoded value must fit in 12-bits)



DWord	Bits	Description
		ValidMsgType = SIC, IME, FBR
	23:16	Mode 2 Cost MODE_INTRA_8x8 Format = U4U4 (encoded value must fit in 12-bits) ValidMsgType = SIC, IME, FBR
	15:8	Mode 1 Cost MODE_INTRA_16x16 Format = U4U4 (encoded value must fit in 12-bits) ValidMsgType = SIC, IME, FBR
	7:0	Mode 0 Cost MODE_INTRA_NONPRED Format = U4U4 (encoded value must fit in 10-bits) ValidMsgType = SIC, IME, FBR
M3.7	31:0	BWD Cost Center 3
M3.6	31:0	FWD Cost Center 3
M3.5	31:0	BWD Cost Center 2
M3.4	31:0	FWD Cost Center 2
M3.3	31:0	BWD Cost Center 1
M3.2	31:0	FWD Cost Center 1
M3.1	31:16	BWD Cost Center 0 Delta Y (BWDCostCenter0Y) This field defines the Y value for the first cost center relative to the picture source MB Y value for the BWD direction.
	15:0	BWD Cost Center 0 Delta X (BWDCostCenter0X) This field defines the X value for the first cost center relative to the picture source MB X value for the BWD direction. Major shape mapping to each cost center: CC0: 16x16_0, 16x8_0, 8x16_0, 8x8_0 CC1: 8x16_1, 8x8_1 CC2: 16x8_1, 8x8_2 CC3: 8x8_3



DWord	Bits	Description
M3.0	31:16	FWDCostCenter 0 Delta Y (FWDCostCenter0Y): This field defines the Y value for the first cost center relative to the picture source MB Y value for the FWD direction.
	15:0	<p>FWDCostCenter 0 Delta X (FWDCostCenter0X): This field defines the X value for the first cost center relative to the picture source MB X value for the FWD direction.</p> <p>Major shape mapping to each cost center:</p> <p>CC0: 16x16_0, 16x8_0, 8x16_0, 8x8_0</p> <p>CC1: 8x16_1, 8x8_1</p> <p>CC2: 16x8_1, 8x8_2</p> <p>CC3: 8x8_3</p>

SIC Input Message Phases

Major changes

- Addition of chroma pixel pairs (CbCr as 16b value) for the left 8, top 8, and top-left 1 corner.
- Addition of chroma mode masks (only 4 modes possible, so 4b mask).
- Addition of intra compute type (Y+CbCr, Y only, disabled).

ValidMsgType = ... identifies the given field is required for each message type. Hardware will ignore these fields under messages where that field is invalid. Hardware output for non valid fields is undefined. X in WX+... below is 3.

DWord	Bits	Name
WX+0.7	31:0	<p>Ref1 SkipCenter 3 Delta XY</p> <p><u>Ref1 Skip Center 3 Delta Y:</u></p> <p>This field defines the Y value for the forward skip center relative to the 8x8 block offset from the source MB Y location in quarter-pel precision associated with Ref1.</p> <p>To match the relative 8x8 block location, the HW will add fixed offsets to the 4 skip centers in each direction to generate the correct pixel location to fetch the data.</p> <p>For SkipCenter 0: VME will add 0 to the user-input Y value.</p> <p>For SkipCenter 1: VME will add 0 to the user-input Y value.</p> <p>For SkipCenter 2: VME will add 32 to the user-input Y value.</p> <p>For SkipCenter 3: VME will add 32 to the user-input Y value.</p> <p>ValidMsgType = SIC</p> <p>Format = S13.2 (2's comp)</p> <p>Hardware Range: [-512.00 to 511.75]</p>



DWord	Bits	Name
		<p>For chroma skip: Format = S12.3 (2's comp) Hardware Range: [-256.000 to 255.875] <u>Ref1SkipCenter3 Delta X:</u> This field defines the X value for the forward skip center relative to the 8x8 block offset from the source MB X location in quarter-pel precision associated with Ref1. To match the relative 8x8 block location, the HW will add fixed offsets to the 4 skip centers in each direction to generate the correct pixel location to fetch the data. For SkipCenter 0: VME will add 0 to the user-input X value. For SkipCenter 1: VME will add 32 to the user-input X value. For SkipCenter 2: VME will add 0 to the user-input X value. For SkipCenter 3: VME will add 32 to the user-input X value.</p> <p>Format = S13.2 (2's comp) Hardware Range: [-2048.00 to 2047.75] For chroma skip: Format = S12.3 (2's comp) Hardware Range: [-1024.000 to 1023.875]</p>
WX+0.6	31:0	Ref0 SkipCenter 3 Delta XY (for definition see M3.7)
WX+0.5	31:0	Ref1 SkipCenter 2 Delta XY (for definition see M3.7)
WX+0.4	31:0	Ref0 SkipCenter 2 Delta XY (for definition see M3.7)
WX+0.3	31:0	Ref1 SkipCenter 1 Delta XY (for definition see M3.7)
WX+0.2	31:0	Ref0 SkipCenter 1 Delta XY (for definition see M3.7)
WX+0.1	31:0	Ref1 SkipCenter 0 Delta XY (for definition see M3.7)
WX+0.0	31:0	Ref0 SkipCenter 0 Delta XY (for definition see M3.7)
WX+1.7	31:0	Neighbor pixel Luma value [23, -1] to [20, -1] . Upper-right pixels from neighbor macroblock C
WX+1.6	31:0	Neighbor pixel Luma value [19, -1] to [16, -1] . Upper-right edge pixels from neighbor macroblock C



DWord	Bits	Name
WX+1.5	31:0	Neighbor pixel Luma value [15, -1] to [12, -1]. Top edge pixels from neighbor macroblock B
WX+1.4	31:0	Neighbor pixel Luma value [11, -1] to [8, -1]. Top edge pixels from neighbor macroblock B
WX+1.3	31:0	Neighbor pixel Luma value [7, -1] to [4, -1]. Top edge pixels from neighbor macroblock B
WX+1.2	31:24	Neighbor pixel Luma value [3, -1]. Fourth top edge pixel from neighbor macroblock B
	23:16	Neighbor pixel Luma value [2, -1]. Third top edge pixel from neighbor macroblock B
	15:8	Neighbor pixel Luma value [1, -1]. Second top edge pixel from neighbor macroblock B
	7:0	Neighbor pixel Luma value [0, -1]. First top edge pixel from neighbor macroblock B
WX+1.1	31:24	Corner Neighbor pixel 0. Its content depends on IntraCornerSwap field. It swaps with Corner Neighbor pixel 1.
	23:10	Reserved: MBZ
	9:8	Intra Compute Type (IntraComputeType) This field specifies the pixel components measured for intra prediction. 00: Luma + Chroma enabled 01: Luma only 1X: Intra disabled
	7:4	AVC Intra Chroma Mode Mask (IntraChromaModeMask) The following mask disables the chroma intra modes from the output. xxx1: VERT xx1x: HORZ x1xx: DC 1xxx: PLANAR
	3:0	AVC Intra 16x16 Mode Mask (Intra16x16ModeMask): Disables given intra mode as follows. xxx1: xx1x: x1xx:



DWord	Bits	Name
		1xxx:
WX+1.0	31:25	Reserved: MBZ
	24:16	AVC Intra 8x8 Mode Mask (Intra16x16ModeMask): Disables given intra mode as follows. x xxxx xxx1: x xxxx xx1x: x xxxx x1xx: x xxxx 1xxx: x xxx1 xxxx: x xx1x xxxx: x x1xx xxxx: x 1xxx xxxx: 1 xxxx xxxx:
	15:9	Reserved: MBZ
	8:0	AVC Intra 4x4 Mode Mask (Intra16x16ModeMask): Disables given intra mode as follows. x xxxx xxx1: x xxxx xx1x: x xxxx x1xx: x xxxx 1xxx: x xxx1 xxxx: x xx1x xxxx: x x1xx xxxx: x 1xxx xxxx: 1 xxxx xxxx:
WX+2.7	31:24	Reserved: MBZ
	23:16	Penalty for Intra4x4 non-DC prediction mode Format: U8
	15:8	Penalty for Intra8x8 non-DC prediction mode Format: U8
	7:0	Penalty for Intra16x16 non-DC prediction mode Format: U8
WX+2.6	31:0	Reserved: MBZ



DWord	Bits	Name
WX+2.5	31:16	Reserved: MBZ
	15:0	Neighbor pixel Chroma value CbCr pair [-1, -1] Corner neighbor pixel pair (CbCr pair, each U8).
WX+2.4	31:28	Intra Predictor Mode for Neighbor B15 (IntraMxMPredModeB15): This field carries the intra prediction mode of the fourth bottom 4x4 block (Block 15 in Numbers of Block4x4 in a 16x16 region) of the top neighbor macroblock B. Definition of the term is according to Sections 8.3.1 and 8.3.2 of the AVC specification.
	27:24	Intra Predictor Mode for Neighbor B14 (IntraMxMPredModeB14): This field carries the intra prediction mode of the third bottom 4x4 block (Block 14 in Numbers of Block4x4 in a 16x16 region) of the top neighbor macroblock B. Definition of the term is according to Sections 8.3.1 and 8.3.2 of the AVC specification.
	23:20	Intra Predictor Mode for Neighbor B11 (IntraMxMPredModeB11): This field carries the intra prediction mode of the second bottom 4x4 block (Block 11 in Numbers of Block4x4 in a 16x16 region) of the top neighbor macroblock B. Definition of the term is according to Sections 8.3.1 and 8.3.2 of the AVC specification.
	19:16	Intra Predictor Mode for Neighbor B10 (IntraMxMPredModeB10): This field carries the intra prediction mode of the first bottom 4x4 block (Block 10 in Numbers of Block4x4 in a 16x16 region) of the top neighbor macroblock B. Definition of the term is according to Sections 8.3.1 and 8.3.2 of the AVC specification.
	15:12	Intra Predictor Mode for Neighbor A15 (IntraMxMPredModeA15): This field carries the intra prediction mode of the fourth rightmost 4x4 block (Block 15 in Numbers of Block4x4 in a 16x16 region) of the left neighbor A. Definition of the term is according to Sections 8.3.1 and 8.3.2 of the AVC specification.
	11:8	Intra Predictor Mode for Neighbor A13 (IntraMxMPredModeA13): This field carries the intra prediction mode of the third rightmost 4x4 block (Block 13 in Numbers of Block4x4 in a 16x16 region) of the left neighbor A. Definition of the term is according to Sections 8.3.1 and 8.3.2 of the AVC specification.
	7:4	Intra Predictor Mode for Neighbor A7 (IntraMxMPredModeA7): This field carries the intra prediction mode of the second rightmost 4x4 block (Block 7 in Numbers of Block4x4 in a 16x16 region) of the left neighbor A.
	3:0	Intra Predictor Mode for Neighbor A5 (IntraMxMPredModeA5): This field carries the intra prediction mode of the first rightmost 4x4 block (Block 5 in Numbers of Block4x4 in a 16x16 region) of the left neighbor A. Definition of the term is according to Sections 8.3.1 and 8.3.2 of the AVC specification. Intra Predictor Modes for Neighbor A and B are only used if MODE_INTRA_NOPRED is not zero. For intra mode selection, bias is applied to the predicted mode if a predictor is present for a



DWord	Bits	Name
		<p>partition. This is achieved by applying a penalty term MODE_INTRA_NONPRED defined in the VME state to the cost functions for non-predicted modes.</p> <p>The predictor for a given partition is from its left neighbor and top neighbor. The intra decision for a partition serves as the predictor for the next partition in the partition order as defined in Numbers of Block4x4 in a 16x16 region and Numbers of Block4x4 in an 8x8 region or numbers of Block8x8 in a 16x16 region.</p> <p>This set of intra predictor mode for neighbor macroblocks are only used for INTRA8x8 and INTRA4x4 modes.</p> <p>Format : U4 (The value of this field is defined in Definition of Intra4x4PredMode which is the same as that in Definition of Intra8x8PredMode.)</p>
WX+2.3	31:24	<p>Corner Neighbor pixel 1. Its content depends on IntraCornerSwap field. It swaps with Corner Neighbor pixel 0.</p> <p>Neighbor pixel Luma value [-1, -1]. The one upper-left edge pixel from neighbor macroblock D, which is the right most edge pixel of D, if IntraCornerSwap field is 1. Or</p> <p>Neighbor pixel Luma value [-1, 15]. The last left edge pixel from neighbor macroblock A, which is the left most edge pixel of D, if IntraCornerSwap field is 0.</p>
	23:0	<p>Neighbor pixel Luma value [-1, 14] to [-1, 12]. Left edge pixels from neighbor macroblock A</p>
WX+2.2	31:0	<p>Neighbor pixel Luma value [-1, 11] to [-1, 8]. Left edge pixels from neighbor macroblock A</p>
WX+2.1	31:0	<p>Neighbor pixel Luma value [-1, 7] to [-1, 4]. Left edge pixels from neighbor macroblock A</p>
WX+2.0	31:24	<p>Neighbor pixel Luma value [-1, 3]. Fourth left edge pixel from neighbor macroblock A</p>
	23:16	<p>Neighbor pixel Luma value [-1, 2]. Third left edge pixel from neighbor macroblock A</p>
	15:8	<p>Neighbor pixel Luma value [-1, 1]. Second left edge pixel from neighbor macroblock A</p>
	7:0	<p>Neighbor pixel Luma value [-1, 0]. First left edge pixel from neighbor macroblock A</p>
WX+3.7	31:0	<p>Neighbor pixel Chroma value CbCr pair [7, -1] to [6, -1]</p>
WX+3.6	31:0	<p>Neighbor pixel Chroma value CbCr pair [5, -1] to [4, -1]</p>
WX+3.5	31:0	<p>Neighbor pixel Chroma value CbCr pair [3, -1] to [2, -1]</p>
WX+3.4	31:0	<p>Neighbor pixel Chroma value CbCr pair [1, -1] to [0, -1]</p>
WX+3.3	31:0	<p>Neighbor pixel Chroma value CbCr pair [-1, 7] to [-1, 6]</p>



DWord	Bits	Name
WX+3.2	31:0	Neighbor pixel Chroma value CbCr pair [-1, 5] to [-1, 4]
WX+3.1	31:0	Neighbor pixel Chroma value CbCr pair [-1, 3] to [-1, 2]
WX+3.0	31:0	Neighbor pixel Chroma value CbCr pair [-1, 1] to [-1, 0]

IME Input Message Phases

Major changes:

- Addition of the search path, no longer accessed via LUT, will come in message payload.
- Streamin\streamout now contains the 9 major shape reference indices per direction.
- Distortion precisions increased to 16b

ValidMsgType = ... identifies the given field is required for each message type. Hardware will ignore these fields under messages where that field is invalid. Hardware output for non valid fields is undefined. X in WX+... below is 3.

DWord	Bits	Name
WX+0.7	31:0	IME Search Path Delta 28-31
WX+0.6	31:0	IME Search Path Delta 24-27
WX+0.5	31:0	IME Search Path Delta 20-23
WX+0.4	31:0	IME Search Path Delta 16-19
WX+0.3	31:0	IME Search Path Delta 12-15
WX+0.2	31:0	IME Search Path Delta 8-11
WX+0.1	31:0	IME Search Path Delta 4-7
WX+0.0	31:0	IME Search Path Delta 0-3 [7:4] (Y) – specifies relative Y distance to the next SU from previous SU in units of SU. [3:0] (X) – specifies relative X distance to the next SU from previous SU in units of SU. Format = U8
WX+1.7	31:0	Reserved MBZ



DWord	Bits	Name
WX+1.6	31:0	Reserved MBZ
WX+1.5	31:0	IME Search Path Delta 52-55
WX+1.4	31:0	IME Search Path Delta 48-51
WX+1.3	31:0	IME Search Path Delta 44-47
WX+1.2	31:0	IME Search Path Delta 40-43
WX+1.1	31:0	IME Search Path Delta 36-39
WX+1.0	31:0	IME Search Path Delta 32-35
WX+2.7	31:0	Reserved MBZ
WX+2.6	31:28	Rec0 Shape 8x8_3 RefID
	27:24	Rec0 Shape 8x8_2 RefID
	23:20	Rec0 Shape 8x8_1 RefID
	19:16	Rec0 Shape 8x8_0 RefID
	15:12	Rec0 Shape 8x16_1 RefID
	11:8	Rec0 Shape 8x16_0 RefID
	7:4	Rec0 Shape 16x8_1 RefID
	3:0	Rec0 Shape 16x8_0 RefID Format = U4
WX+2.5	31:16	Rec0 Shape 16x16 Y (relative to source MB)
	15:0	Rec0 Shape 16x16 X (relative to source MB)
WX+2.4	31:20	Reserved MBZ
	19:16	Rec0 Shape 16x16 RefID Format = U4
	15:0	Rec0 Shape 16x16 Distortion Format = U16
WX+2.3	31:16	Rec0 Shape 8x8_3 Distortion Format = U16 Hardware only uses 14 bits. Upper bits ignored (True for all 8x8_X Distortions).
	15:0	Rec0 Shape 8x8_2 Distortion Format = U16
WX+2.2	31:16	Rec0 Shape 8x8_1 Distortion Format = U16



DWord	Bits	Name
	15:0	Rec0 Shape 8x8_0 Distortion Format = U16
WX+2.1	31:16	Rec0 Shape 8x16_1 Distortion Format = U16 Hardware only uses 15 bits. Upper bits ignored (True for all 8x16_X Distortions).
	15:0	Rec0 Shape 8x16_0 Distortion Format = U16
WX+2.0	31:16	Rec0 Shape 16x8_1 Distortion Format = U16 Hardware only uses 15 bits. Upper bits ignored (True for all 16x8_X Distortions).
	15:0	Rec0 Shape 16x8_0 Distortion Format = U16
WX+3.7	31:16	Rec0 Shape 8x8_3 Y (relative to source MB)
	15:0	Rec0 Shape 8x8_3 X (relative to source MB)
WX+3.6	31:16	Rec0 Shape 8x8_2 Y (relative to source MB)
	15:0	Rec0 Shape 8x8_2 X (relative to source MB)
WX+3.5	31:16	Rec0 Shape 8x8_1 Y (relative to source MB)
	15:0	Rec0 Shape 8x8_1 X (relative to source MB)
WX+3.4	31:16	Rec0 Shape 8x8_0 Y (relative to source MB)
	15:0	Rec0 Shape 8x8_0 X (relative to source MB)
WX+3.3	31:16	Rec0 Shape 8x16_1 Y (relative to source MB)
	15:0	Rec0 Shape 8x16_1 X (relative to source MB)
WX+3.2	31:16	Rec0 Shape 8x16_0 Y (relative to source MB)
	15:0	Rec0 Shape 8x16_0 X (relative to source MB)
WX+3.1	31:16	Rec0 Shape 16x8_1 Y (relative to source MB)
	15:0	Rec0 Shape 16x8_1 X (relative to source MB)
WX+3.0	31:16	Rec0 Shape 16x8_0 Y (relative to source MB)
	15:0	Rec0 Shape 16x8_0 X (relative to source MB)
WX+4.7	31:0	Reserved MBZ
WX+4.6	31:28	Rec1 Shape 8x8_3 RefID
	27:24	Rec1 Shape 8x8_2 RefID
	23:20	Rec1 Shape 8x8_1 RefID
	19:16	Rec1 Shape 8x8_0 RefID
	15:12	Rec1 Shape 8x16_1 RefID
	11:8	Rec1 Shape 8x16_0 RefID
	7:4	Rec1 Shape 16x8_1 RefID
	3:0	Rec1 Shape 16x8_0 RefID



DWord	Bits	Name
		Format = U4
WX+4.5	31:16	Rec1 Shape 16x16 Y (relative to source MB)
	15:0	Rec1 Shape 16x16 X (relative to source MB)
WX+4.4	31:20	Reserved MBZ
	19:16	Rec1 Shape 16x16 RefID Format = U4
	15:0	Rec1 Shape 16x16 Distortion Format = U16
WX+4.3	31:16	Rec1 Shape 8x8_3 Distortion Format = U16 Hardware only uses 14 bits. Upper bits ignored (True for all 8x8_X Distortions).
	15:0	Rec1 Shape 8x8_2 Distortion Format = U16
WX+4.2	31:16	Rec1 Shape 8x8_1 Distortion Format = U16
	15:0	Rec1 Shape 8x8_0 Distortion Format = U16
WX+4.1	31:16	Rec1 Shape 8x16_1 Distortion Format = U16 Hardware only uses 15 bits. Upper bits ignored (True for all 8x16_X Distortions).
	15:0	Rec1 Shape 8x16_0 Distortion Format = U16
WX+4.0	31:16	Rec1 Shape 16x8_1 Distortion Format = U16 Hardware only uses 15 bits. Upper bits ignored (True for all 16x8_X Distortions).
	15:0	Rec1 Shape 16x8_0 Distortion Format = U16
WX+5.7	31:16	Rec1 Shape 8x8_3 Y (relative to source MB)
	15:0	Rec1 Shape 8x8_3 X (relative to source MB)
WX+5.6	31:16	Rec1 Shape 8x8_2 Y (relative to source MB)
	15:0	Rec1 Shape 8x8_2 X (relative to source MB)
WX+5.5	31:16	Rec1 Shape 8x8_1 Y (relative to source MB)
	15:0	Rec1 Shape 8x8_1 X (relative to source MB)
WX+5.4	31:16	Rec1 Shape 8x8_0 Y (relative to source MB)
	15:0	Rec1 Shape 8x8_0 X (relative to source MB)
WX+5.3	31:16	Rec1 Shape 8x16_1 Y (relative to source MB)
	15:0	Rec1 Shape 8x16_1 X (relative to source MB)
WX+5.2	31:16	Rec1 Shape 8x16_0 Y (relative to source MB)



DWord	Bits	Name
	15:0	Rec1 Shape 8x16_0 X (relative to source MB)
WX+5.1	31:16	Rec1 Shape 16x8_1 Y (relative to source MB)
	15:0	Rec1 Shape 16x8_1 X (relative to source MB)
WX+5.0	31:16	Rec1 Shape 16x8_0 Y (relative to source MB)
	15:0	Rec1 Shape 16x8_0 X (relative to source MB)

FBR Input Message Phases

Major changes:

- Consists of the 32 sub-block motion vectors following the same 32MV format as the rest of VME.

ValidMsgType = ... identifies the given field is required for each message type. Hardware will ignore these fields under messages where that field is invalid. Hardware output for non valid fields is undefined. X in WX+... below is 3.

DWord	Bit(s)	Name
WX+0.7	31:0	Ref1 Sub-block XY 3
WX+0.6	31:0	Ref0 Sub-block XY 3
WX+0.5	31:0	Ref1 Sub-block XY 2
WX+0.4	31:0	Ref0 Sub-block XY 2
WX+0.3	31:0	Ref1 Sub-block XY 1
WX+0.2	31:0	Ref0 Sub-block XY 1
WX+0.1	31:0	Ref1 Sub-block XY 0
WX+0.0	31:16	<p>Ref0 Sub-block Y 0</p> <p>The y-coordinate of Motion Vector 0 for Reference 0, relative to source MB location.</p> <p>Note: All MVs must be replicated for each shape. (e.g. for luma 16x16 shape and chroma 8x8, all Sub-block MVs must be the same. For luma 8x8 shape and chroma 4x4, each 8x8 must have its respective Sub-block MVs be replicated).</p> <p>Format = S13.2 (2's comp)</p> <p>Hardware Range: [-2048.00 to 2047.75]</p>



DWord	Bit(s)	Name
	15:0	<p>Ref0 Sub-block X 0</p> <p>The x-coordinate of Motion Vector 0 for Reference 0, relative to source MB location.</p> <p>Note: All MVs must be replicated for each shape. (e.g. for luma 16x16 shape and chroma 8x8, all Sub-block MVs must be the same. For luma 8x8 shape and chroma 4x4, each 8x8 must have its respective Sub-block MVs be replicated).</p> <p>Format = S13.2 (2's comp)</p> <p>Hardware Range: [-2048.00 to 2047.75]</p>
WX+1.7	31:0	Ref1 Sub-block XY 7
WX+1.6	31:0	Ref0 Sub-block XY 7
WX+1.5	31:0	Ref1 Sub-block XY 6
WX+1.4	31:0	Ref0 Sub-block XY 6
WX+1.3	31:0	Ref1 Sub-block XY 5
WX+1.2	31:0	Ref0 Sub-block XY 5
WX+1.1	31:0	Ref1 Sub-block XY 4
WX+1.0	31:0	Ref0 Sub-block XY 4
WX+2.7	31:0	Ref1 Sub-block XY 11
WX+2.6	31:0	Ref0 Sub-block XY 11
WX+2.5	31:0	Ref1 Sub-block XY 10
WX+2.4	31:0	Ref0 Sub-block XY 10
WX+2.3	31:0	Ref1 Sub-block XY 9
WX+2.2	31:0	Ref0 Sub-block XY 9
WX+2.1	31:0	Ref1 Sub-block XY 8



DWord	Bit(s)	Name
WX+2.0	31:0	Ref0 Sub-block XY 8
WX+3.7	31:0	Ref1 Sub-block XY 15
WX+3.6	31:0	Ref0 Sub-block XY 15
WX+3.5	31:0	Ref1 Sub-block XY 14
WX+3.4	31:0	Ref0 Sub-block XY 14
WX+3.3	31:0	Ref1 Sub-block XY 13
WX+3.2	31:0	Ref0 Sub-block XY 13
WX+3.1	31:0	Ref1 Sub-block XY 12
WX+3.0	31:0	Ref0 Sub-block XY 12

Return Data Message Phases

Major changes:

- Many of the fields are not valid output for all message types.
- Addition of new message phase, which has the block reference IDs and forward transform skip check data.
- Intra chroma distortion and best mode are reported.
- All U14 distortion values are now U16.

ValidMsgType = "..." identifies that the given field is required for each message type. Hardware will ignore these fields under messages where that field is invalid. Hardware output for non valid fields is undefined.

DWord	Bit	Description
W0.7	31:16	Total VME Stalled Clocks: Counts the number of clocks VME is stalled\starved while processing this request, due to cache misses. Format: U16 ValidMsgType = SIC, IME, FBR
	15:0	Total VME Compute Clocks: Counts the number of clocks VME is processing this request, but not stalled\starved as a result of cache misses. Format: U16 ValidMsgType = SIC, IME, FBR
W0.6	31:26	Alternate Search Path Length: Counts the number of unique search units computed by VME for the alternate search path for dual reference or dual search path. If the search path would return to a previously processed SU, it would not be reprocessed and hence not recounted. The value of [W0.1 15:8] is the overall total search units processed from both paths whereas this value is the



DWord	Bit	Description
		<p>contribution only from the second search path. Note: Whenever VME is in a mode that processes only a single search path, this field will be 0x0.</p> <p>Format: U6, Range of 0-48</p> <p>ValidMsgType = IME</p>
	25	<p>MaxMV Occurred:</p> <p>This bit is set if the MaxMV event prevented the lowest distortion solution is rejected due to lack of motion vectors.</p> <p>Format: U1</p> <p>Valid only for Luma Source Size = 16x16.</p> <p>ValidMsgType = IME</p>
	24	<p>EarlyIMESStop Occurred:</p> <p>This bit is set if the EarlyIMESStop threshold is satisfied and IME discontinues searching.</p> <p>Format: U1</p> <p>ValidMsgType = IME</p>
	23:16	<p>Sub-Macroblock Prediction Mode (SubMbPredMode): If InterMbMode is INTER8x8, this field describes the prediction mode of the sub-partitions in the four 8x8 sub-macroblock. It contains four subfields each with 2-bits, corresponding to the four 8x8 sub-macroblocks in sequential order.</p> <p>This field is derived from sub_mb_type for a BP_8x8 macroblock.</p> <p>This field is derived from MbType for a non-BP_8x8 inter macroblock, and carries redundant information as MbType).</p> <p>If InterMbMode is INTER16x16, INTER16x8 or INTER8x16, this field carries the prediction modes of the sub macroblock (one 16x16, two 16x8 or two 8x16). The unused bits are set to zero.</p> <p>Bits [1:0]: SubMbPredMode[0]</p> <p>Bits [3:2]: SubMbPredMode[1]</p> <p>Bits [5:4]: SubMbPredMode[2]</p> <p>Bits [7:6]: SubMbPredMode[3]</p> <p>ValidMsgType = SIC, IME, FBR</p>
	15:8	<p>Sub-Macroblock Shape (SubMbShape): This field describes the subdivision of the four 8x8 sub-macroblocks. It contains four subfields each with 2-bits, corresponding to the four 8x8 sub macroblocks in sequential order.</p> <p>This field is derived from sub_mb_type for a BP_8x8 or equivalent macroblock.</p> <p>This field is forced to 0 for a non-BP_8x8 inter macroblock, and effectively carries redundant</p>



DWord	Bit	Description																
		<p>information as MbType).</p> <p>This field is only valid If InterMbMode is INTER8x8, Otherwise, it is set to zero.</p> <p>Bits [1:0]: SubMbShape[0]</p> <p>Bits [3:2]: SubMbShape[1]</p> <p>Bits [5:4]: SubMbShape[2]</p> <p>Bits [7:6]: SubMbShape[3]</p> <p>ValidMsgType = SIC, IME, FBR</p>																
	7:0	<p>Macroblock Intra Structure (MbIntraStruct): This is a bitmask specifies neighbor macroblock availability. This allows software to constrain intra prediction mode search.</p> <p>This field is simply copied from the input message (to reduce software overhead of forming the output message to PAK).</p> <table border="1"> <thead> <tr> <th>Bits</th> <th>MotionVerticalFieldSelect Index</th> </tr> </thead> <tbody> <tr> <td>7</td> <td>Reserved : MBZ (for IntraPredAvailFlagF – F (pixel[-1,7] available for MbAff)</td> </tr> <tr> <td>6</td> <td>Reserved : MBZ (for IntraPredAvailFlagA/E – A (left neighbor top half for MbAff)</td> </tr> <tr> <td>5</td> <td>IntraPredAvailFlagE/A – A (Left neighbor or Left bottom half)</td> </tr> <tr> <td>4</td> <td>IntraPredAvailFlagB – B (Upper neighbor)</td> </tr> <tr> <td>3</td> <td>IntraPredAvailFlagC – C (Upper left neighbor)</td> </tr> <tr> <td>2</td> <td>IntraPredAvailFlagD – D (Upper right neighbor)</td> </tr> <tr> <td>1:0</td> <td>ChromaIntraPredMode</td> </tr> </tbody> </table> <p>Note: This 8b field is MBZ when IntraComputeType == 1X (when intra is disabled).</p> <p>ValidMsgType = SIC</p>	Bits	MotionVerticalFieldSelect Index	7	Reserved : MBZ (for IntraPredAvailFlagF – F (pixel[-1,7] available for MbAff)	6	Reserved : MBZ (for IntraPredAvailFlagA/E – A (left neighbor top half for MbAff)	5	IntraPredAvailFlagE/A – A (Left neighbor or Left bottom half)	4	IntraPredAvailFlagB – B (Upper neighbor)	3	IntraPredAvailFlagC – C (Upper left neighbor)	2	IntraPredAvailFlagD – D (Upper right neighbor)	1:0	ChromaIntraPredMode
Bits	MotionVerticalFieldSelect Index																	
7	Reserved : MBZ (for IntraPredAvailFlagF – F (pixel[-1,7] available for MbAff)																	
6	Reserved : MBZ (for IntraPredAvailFlagA/E – A (left neighbor top half for MbAff)																	
5	IntraPredAvailFlagE/A – A (Left neighbor or Left bottom half)																	
4	IntraPredAvailFlagB – B (Upper neighbor)																	
3	IntraPredAvailFlagC – C (Upper left neighbor)																	
2	IntraPredAvailFlagD – D (Upper right neighbor)																	
1:0	ChromaIntraPredMode																	
W0.5	31:16	LumaIntraPredModes[3]																
	15:0	LumaIntraPredModes[2]																
W0.4	31:16	LumaIntraPredModes[1]																
	15:0	<p>LumaIntraPredModes[0]</p> <p>Specifies the Luma Intra Prediction mode for four 4x4 sub-block, four 8x8 block or one intra16x16 of a MB.</p> <p>4-bit per 4x4 sub-block (Transform8x8Flag=0, Mbtype=0 and intraMbFlag=1) or 8x8 block</p>																



DWord	Bit	Description
		<p>(Transform8x8Flag=1, Mbtype=0, MbFlag=1), since there are 9 intra modes.</p> <p>4-bit for intra16x16 MB (Transform8x8Flag=0, Mbtype=1 to 24 and intraMbFlag=1), but only the LSBit[1:0] is valid, since there are only 4 intra modes.</p> <p>Note: The LumaIntraPredModes are MBZ when IntraComputeType == 1X (when intra is disabled).</p> <p>ValidMsgType = SIC</p>
W0.3	31:16	<p>BestChromaIntraDistortion</p> <p>This field provides the ChromaIntraMode distortion (sum of Cb and Cr dist).</p> <p>Note: This field is MBZ when IntraComputeType == 1X (when intra is disabled).</p> <p>Format = U16</p> <p>ValidMsgType = SIC</p>
	15:0	<p>BestIntraDistortion</p> <p>The IntraMbMode will indicate if this is a 16x16/8x8/4x4 distortion</p> <p>Note: This field is MBZ when IntraComputeType == 1X (when intra is disabled)..</p> <p>Format = U16</p> <p>ValidMsgType = SIC</p>
W0.2	31:16	<p>SkipRawDistortion</p> <p>This field contains Skip Raw Distortion which may be used by software to further refine the skip decision.</p> <p>Note: This field is MBZ when SkipModeEn is not set (when skip is disabled).</p> <p>Format = U16</p> <p>ValidMsgType = SIC</p>
	15:0	<p>InterDistortion</p> <p>This field provides the best inter distortion.</p> <p>Format = U16</p> <p>ValidMsgType = SIC, IME, FBR</p>
W0.1	31:27	Reserved: MBZ
	26:16	Sum Ref1 Inter Dist Upper 10 bits (SumInterDistL1Upper)
	15:8	Search Path Length: This field returns the number of SU it takes in the integer search. It includes predetermined search path and dynamic search path.



DWord	Bit	Description
		Format: U8 ValidMsgType = IME
	7:4	Reference 1 border reached: bitmask indicating whether any border of reference 1 is reached by one or more motion vectors in the winning inter mode. xxx1: left border reached xx1x: right border reached x1xx: top border reached 1xxx: bottom border reached ValidMsgType = IME
	3:0	Reference 0 border reached: bitmask indicating whether any border of reference 0 is reached by one or more motion vectors in the winning inter mode. xxx1: left border reached xx1x: right border reached x1xx: top border reached 1xxx: bottom border reached ValidMsgType = IME
W0.0	31	Reserved: MBZ
	30	Reserved: MBZ
	29	Reserved: MBZ
	28:24	MvQuantity Specify the number of MVs in packed format (in unit of motion vectors). Note: This field is provided to help with software to meet conformance requirements such as maximum number of motion vectors for two consecutive macroblocks. Format: U5, valid from 0 to 32 ValidMsgType = SIC, IME, FBR
	23	ExtendedForm. This field specifies that LumaIntraMode 's are fully replicated in 4x4 sub-blocks respectively. And motion vectors must be in unpacked form as well. This non-DXVA form is used for optimal kernel performance.



DWord	Bit	Description
		<p>This is reserved MBZ and the HW will always extend.</p> <p>ValidMsgType = SIC</p>
	22:21	<p>Reserved: MBZ</p>
	20:16	<p>IntraMbType</p> <p>This field is encoded to match with the inter type determined as described in the next section. It follows a unified encoding for intra macroblocks according to AVC Spec.</p> <p>Note: This field is MBZ when IntraComputeType == 1X (when intra is disabled)..</p> <p>ValidMsgType = SIC</p>
	15	<p>Transform8x8Flag (Transform 8x8 Flag)</p> <p>This field indicates that 8x8 transform is recommended.</p> <p>It is set to 1 if IntraMbFlag = INTRA and IntraMbMode = INTRA_8x8.</p> <p>For IntraMbFlag = INTER. If T8x8FlagForInterEn = 0, this field is set to 0 by VME hardware. If T8x8FlagForInterEn = 1, this field is set to 1 if there is no sub macroblock size less than 8x8 (noSubMbPartSizeLessThan8x8Flag = 1).</p> <p>0: 4x4 integer transform 1: 8x8 integer transform</p> <p>Note: This bit will be always 0 for non-16x16 source block cases.</p> <p>ValidMsgType = IME, FBR</p>
	14	<p>FieldMbFlag</p> <p>This field indicates the inter prediction result is field or frame.</p> <p>It is always set to SrcAccess.</p> <p>0: frame macroblock 1: field macroblock</p> <p>ValidMsgType = SIC, IME, FBR</p>
	13	<p>Reserved: MBZ</p>
	12:8	<p>InterMbType</p> <p>This field is encoded to match with the inter type determined as described in the next section. It follows an unified encoding for inter macroblocks according to AVC Spec.</p> <p>ValidMsgType = SIC, IME, FBR</p>



DWord	Bit	Description
	7	<p>FieldMbPolarityFlag</p> <p>This field indicates the field polarity of the current macroblock.</p> <p>Unique for AVC standard, within an MbAff frame picture, this field may be different per macroblock and is set to 1 only for the second macroblock in an MbAff pair if FieldMbFlag is set. Otherwise, it is set to 0.</p> <p>Within a field picture in most coding standard, this field is a constant for the whole field picture. It is set to 1 if the current picture is the bottom field picture. Otherwise, it is set to 0.</p> <p>This field is reserved and MBZ for a progressive frame picture.</p> <p>VME hardware set this field to 1 if the source block is a field block from the bottom field and otherwise sets it to 0. This is accomplished by the following equation using input signals SrcAccess and SrcY: $\text{SrcAccess} \&\& (\text{bit0}(\text{SrcY}) == 1)$.</p> <p>0 = Current macroblock is a field macroblock from the top field</p> <p>1 = Current macroblock is a field macroblock from the bottom field</p> <p>Equals $\text{SrcAccess} \&\& \text{SrcFieldPolarity}(\text{M1.7}[19])$</p> <p>ValidMsgType = SIC, IME, FBR</p>
	6	Reserved: MBZ
	5:4	<p>IntraMbMode</p> <p>This field is provided to carry redundant information as that in MbType. The full extended definition of this field allows kernel software to help update the MbType field when outputting controls to the MFX PAK encoding.</p> <p>VME outputs this field regardless of MbIntraFlag value if intra mode is enabled.</p> <p>ValidMsgType = SIC</p>
	3:2	Reserved: MBZ
	1:0	<p>InterMbMode</p> <p>This field is provided to carry redundant information as that in MbType. The full extended definition of this field allows kernel software to help update the MbType field when outputting controls to the MFX PAK encoding.</p> <p>VME outputs this field regardless of MbIntraFlag value if inter mode is enabled.</p> <p>ValidMsgType = SIC, IME, FBR</p>
W1.7 to W1.2	31:0 Each	<p>MVb[3] to MVb[1]. Motion vectors 3 to 1 for Reference 1, and</p> <p>MVa[3] to MVa[1]. Motion vectors 3 to 1 for Reference 0</p> <p>ValidMsgType = SIC, IME, FBR</p>



DWord	Bit	Description
W1.1	31:16	<p>MVb[0].y: returning the y-coordinate of Motion Vector 0 for Reference 1, relative to source MB location.</p> <p>Format = S13.2 (2's comp)</p> <p>Hardware Range: [-2048.00 to 2047.75]</p> <p>ValidMsgType = SIC, IME, FBR</p>
	15:0	<p>MVb[0].x: returning the x-coordinate of Motion Vector 0 (co-located w/ subblock_4x4_0) for Reference 1, relative to source MB location. Its meaning is determined by MbType.</p> <p>Format = S13.2 (2's comp)</p> <p>Hardware Range: [-2048.00 to 2047.75]</p> <p>ValidMsgType = SIC, IME, FBR</p>
W1.0	31:16	<p>MVa[0].y: returning the y-coordinate of Motion Vector 0 for Reference 0, relative to source MB location.</p> <p>Format = S13.2 (2's comp)</p> <p>Hardware Range: [-2048.00 to 2047.75]</p> <p>ValidMsgType = SIC, IME, FBR</p>
	15:0	<p>MVa[0].x: returning the x-coordinate of Motion Vector 0 (co-located w/ the first pixel in 6 by 2 block) for Reference 0, relative to source MB location. Its meaning is determined by MbType.</p> <p>Hardware Range: [-2048.00 to 2047.75]</p> <p>ValidMsgType = IME</p> <p>MVa[0].x: returning the x-coordinate of Motion Vector 0 (co-located w/ subblock_4x4_0) for Reference 0, relative to source MB location. Its meaning is determined by MbType.</p> <p>The returned motion vectors are placed in a fixed data format, with up to 16 motion vectors for one reference and the motion vectors from reference 0 and 1 interleaved.</p> <p>Format = S13.2 (2's comp)</p> <p>Hardware Range: [-2048.00 to 2047.75]</p> <p>ValidMsgType = SIC, IME, FBR</p>
W2.7 to W2.0	31:0 Each	<p>MVb[7] to MVb[4]. Motion vectors 7 to 4 for Reference 1, and</p> <p>MVa[7] to MVa[4]. Motion vectors 7 to 4 for Reference 0</p> <p>ValidMsgType = SIC, IME, FBR</p>
W3.7 to W3.0	31:0 Each	<p>MVb[11] to MVb[8]. Motion vectors 11 to 8 for Reference 1, and</p>



DWord	Bit	Description
		MVa[11] to MVa[8] . Motion vectors 11 to 8 for Reference 0 ValidMsgType = SIC, IME, FBR
W4.7 to W4.0	31:0 Each	MVb[15] to MVb[12] . Motion vectors 15 to 12 for Reference 1, and MVa[15] to MVa[12] . Motion vectors 15 to 12 for Reference 0 ValidMsgType = SIC, IME, FBR
W5.7 to W5.1	31:0 Each	InterDistortion[15] to InterDistortion[2] . Inter-prediction-distortion associated with motion vector 15 to 2. Its meaning is determined by sub-shape. ValidMsgType = SIC, IME, FBR
W5.0	31:16	InterDistortion[1] . Inter-prediction-distortion with motion vector 1 (co-located with subblock_4x4_1). Its meaning is determined by sub-shape. Format = U16 ValidMsgType = SIC, IME, FBR
	15:0	InterDistortion[0] . Inter-prediction-distortion associated with motion vector 0 (co-located with subblock_4x4_0). Its meaning is determined by sub-shape. It must be zero if the corresponding sub-shape is not chosen. This field may be associated with MVa[0] and/or MVb[0], depending on the resulting prediction mode for the sub-block. If the corresponding MV field is created by "duplication", this field must be zero. For 1MVP skip messages, the 16x16 distortion (sad + mv cost + ref cost) is present here. For 4MVP skip messages, the 4 8x8 distortions (sad + mv cost + ref cost) are present here. Format = U16
W6.7	31:16	Max Ref1 Inter Dist (MaxRef1InterDist) Reserved
	15:0	Max Ref0 Inter Dist (MaxRef0InterDist)
W6.6	31:27	Reserved
	26:0	Sum Ref0 Inter Dist (SumRef0InterDist)
W6.5	31:16	Block 0 Chroma Cr Coeff Magnitude Clip Sum Sum of how much all the coefficients across 1 block exceeded their respective threshold. Note: This field is MBZ when SkipModeEn is not set (when skip is disabled)..



DWord	Bit	Description
		Format = U16 ValidMsgType = SIC
	15:0	Block 0 Chroma Cb Coeff Magnitude Clip Sum Sum of how much all the coefficients across 1 block exceeded their respective threshold. Note: This field is MBZ when SkipModeEn is not set (when skip is disabled).. Format = U16 ValidMsgType = SIC
W6.4	31:16	Sum Ref1 Inter Dist lower 16 bits (SumInterDistL1Lower)
	15:8	Block 0 Chroma Cr NZC Count of the coefficients across 1 block that exceeded their respective threshold. Note: This field is MBZ when SkipModeEn is not set (when skip is disabled).. Format = U8 ValidMsgType = SIC
	7:0	Block 0 Chroma Cb NZC Count of the coefficients across 1 block that exceeded their respective threshold. Note: This field is MBZ when SkipModeEn is not set (when skip is disabled).. Format = U8 ValidMsgType = SIC
W6.3	31:16	Block 3 Luma Coeff Magnitude Clip Sum
	15:0	Block 2 Luma Coeff Magnitude Clip Sum
W6.2	31:16	Block 1 Luma Coeff Magnitude Clip Sum
	15:0	Block 0 Luma Coeff Magnitude Clip Sum Sum of how much all the coefficients across 1 block exceeded their respective threshold. Note: This field is MBZ when SkipModeEn is not set (when skip is disabled).. Format = U16 ValidMsgType = SIC
W6.1	31:24	Block 3 Luma NZC
	23:16	Block 2 Luma NZC
	15:8	Block 1 Luma NZC



DWord	Bit	Description
	7:0	<p>Block 0 Luma NZC</p> <p>Count of the coefficients across 1 block that exceeded their respective threshold.</p> <p>Note: This field is MBZ when SkipModeEn is not set (when skip is disabled)..</p> <p>Format = U8</p> <p>ValidMsgType = SIC</p>
W6.0	31:28	Bwd Block 3 RefID
	27:24	Fwd Block 3 RefID
	23:20	Bwd Block 2 RefID
	19:16	Fwd Block 2 RefID
	15:12	Bwd Block 1 RefID
	11:8	Fwd Block 1 RefID
	7:4	<p>Bwd Block 0 RefID</p> <p>Reference ID for backward block 0. Note: even if shape is 16x16, this field is defined per block, hence VME will replicate the RefID for larger shapes</p> <p>Replication happens only in IME.</p> <p>For CRE (SIC/FBR), this is a pass through field.</p> <p>Format = U4</p> <p>ValidMsgType = SIC, IME, FBR</p>
3:0	<p>Fwd Block 0 RefID</p> <p>Reference ID for forward block 0. Note: even if shape is 16x16, this field is defined per block, hence VME will replicate the RefID for larger shapes.</p> <p>Replication happens only in IME.</p> <p>For CRE (SIC/FBR), this is a pass through field.</p> <p>Format = U4</p> <p>ValidMsgType = SIC, IME, FBR</p>	

IME StreamOut

Note: IME Streamout follows the same format as the IME Streamin message phases (IME2-IME5).



3D Pipeline Stages

The following table lists the various stages of the 3D pipeline and describes their major functions.

Project	Pipeline Stage	Functions Performed
	Command Stream (CS)	The Command Stream stage is responsible for managing the 3D pipeline and passing commands down the pipeline. In addition, the CS unit reads "constant data" from memory buffers and places it in the URB. Note that the CS stage is shared between the 3D, GPGPU and Media pipelines.
	Vertex Fetch (VF)	The Vertex Fetch stage, in response to 3D Primitive Processing commands, is responsible for reading vertex data from memory, reformatting it, and writing the results into Vertex URB Entries. It then outputs primitives by passing references to the VUEs down the pipeline.
	Vertex Shader (VS)	The Vertex Shader stage is responsible for processing (shading) incoming vertices by passing them to VS threads.
	Hull Shader (HS)	The Hull Shader is responsible for processing (shading) incoming patch primitives as part of the tessellation process.
	Tessellation Engine (TE)	The Tessellation Engine is responsible for using tessellation factors (computed in the HS stage) to tessellate U,V parametric domains into domain point topologies.
	Domain Shader (DS)	The Domain Shader stage is responsible for processing (shading) the domain points (generated by the TE stage) into corresponding vertices.
	Geometry Shader (GS)	The Geometry Shader stage is responsible for processing incoming objects by passing each object's vertices to a GS thread.
	Stream Output Logic (SOL)	The Stream Output Logic is responsible for outputting incoming object vertices into Stream Out Buffers in memory.
	Clipper (CLIP)	The Clipper stage performs Clip Tests on incoming objects and clips objects if required. Objects are clipped using fixed-function hardware.
	Strip/Fan (SF)	The Strip/Fan stage performs object setup. Object setup uses fixed-function hardware.
	Windower/Masker (WM)	The Windower/Masker performs object rasterization and determines visibility coverage.



3D Pipeline-Level State

This section contains table commands for the 3D Pipeline Level.

Project:	HSW
<p>Push Constant URB Allocation</p> <p>The push constants are stored into the URB which is part of the L3\$. Software is required to program the hardware to allocate space in the URB for each shader push constant. The software is limited to the bottom address of the URB and must ensure that none of the shaders have overlapping handles. Below is a diagram that represents a possible programming of the URB with Push Constants.</p>	

Project	URB Allocation Changes
HSW	The sizes of the regions in the diagram double to 32KB and 480KB, respectively.

Project:	HSW
<p>URB Allocation</p> <div style="display: flex; justify-content: space-around; margin-bottom: 10px;"> Push Constants Handle Allocations </div> <p>The diagram illustrates the URB allocation. It is divided into two main sections: Push Constants and Handle Allocations. The Push Constants section is shown as a light blue bar divided into four equal-width blocks, each labeled with a shader type and 'PC' (VS PC, DS PC, GS PC, PS PC). Above this bar, the text '16KB' is written in red. The Handle Allocations section is shown as a light green bar divided into four equal-width blocks, each labeled with a shader type and 'HANDLES' (VS HANDLES, HS HANDLES, DS HANDLES, GS HANDLES). Above this bar, the text '240KB' is written in red. A horizontal line with vertical end-caps spans the width of both sections.</p>	
<p>In the above scheme we are allocating 16KB of push constants and 240KB of URB space. The handle allocation is shown in the order of the FF pipeline but with the current hardware and state, the software can program these to be any order and may size them to zero. Software may also use some if not all of the 16KB above as handle allocations as long as none of the push constants or handle allocations</p>	



Project:	HSW
<p>overlap. The only limitations are the sizes based off the table below and the restrictions in granularity which are specified in the command descriptions of the URB state and the push constant allocation state for each fixed function.</p> <p>The next table specifies the maximum size of each buffer.</p>	

Project	Max Constant Buffer	URB Size
HSW	32KB	512KB
HSW	16KB	128KB

Project:	HSW
<p>Below is a diagram that represents how the hardware may move and store one CONSTANT_BUFFER command for a fixed function shader:</p>	

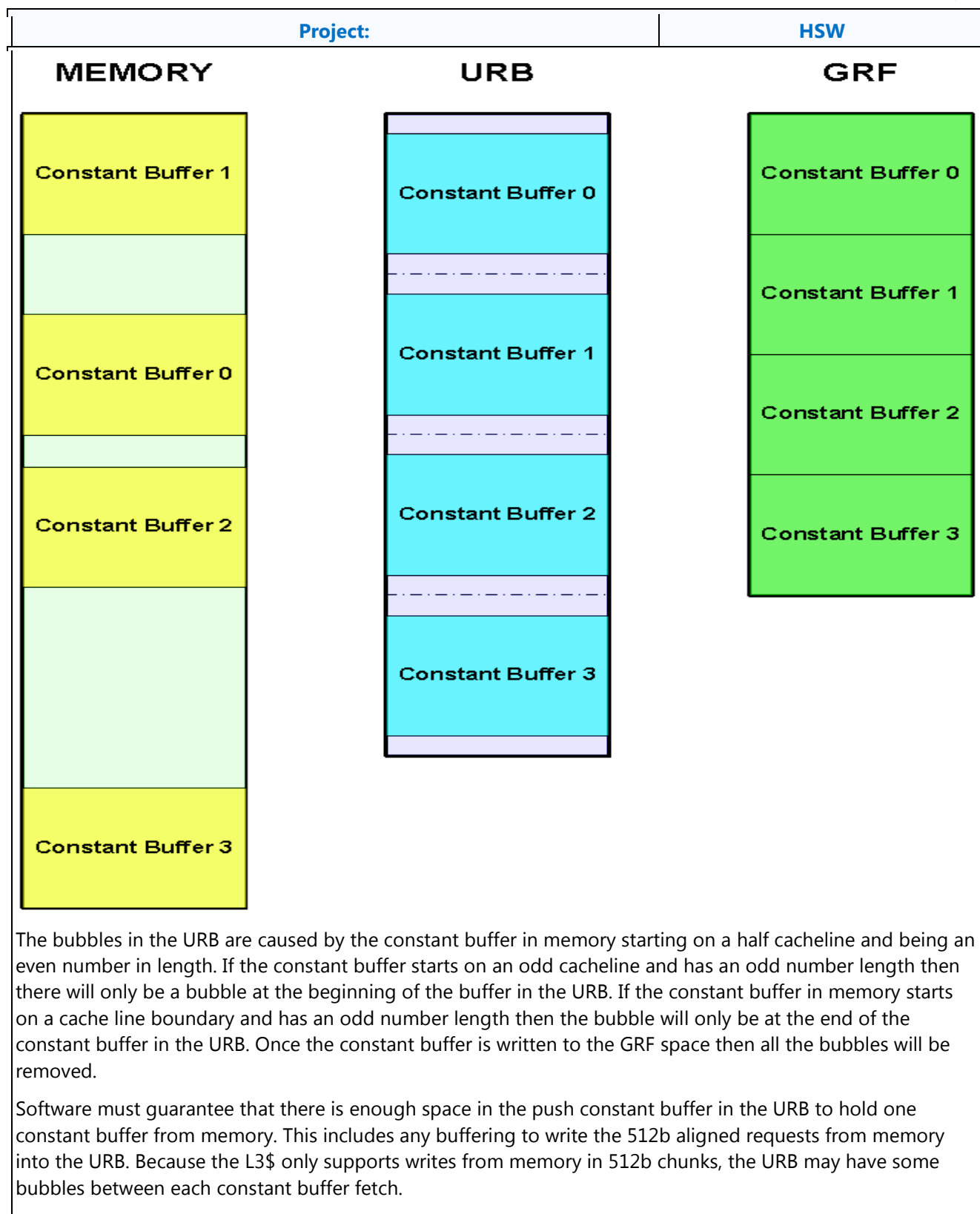



Statistics

Statistics Gathering

The table below describes how the device supports the required API statistics counters.

API-level Statistic	HW Support
<p>IAVertices = # of vertices IA generated. May or may not include (a) vertices in partial primitives, (b) unused adjacent-only vertices. Not affected by vertex caching.</p>	<p>VF maintains IA_VERTICES_COUNT. Will include unused adjacent-only vertices. Will not include vertices in partial primitives.</p>
<p>IAPrimitives = # of primitives (objects) IA generated. May or may not include partial primitives.</p>	<p>VF maintains IA_PRIMITIVES_COUNT. Will not include partial primitives. Will not count patch topologies that do not match what the HS or GS expects as input, if enabled (i.e., mismatching patch topologies are discarded by VF).</p>
<p>VSInvocations = # of times VS is executed. May be affected by vertex caching. May or may not include (a) shared vertices in non-indexed strips, (b) vertices in partial primitives, (c) unused adjacent-only vertices.</p>	<p>VS maintains VS_INVOCATION_COUNT. Impacted by vertex caching. Will not include vertices in partial primitives. <i>Will</i> include unused adjacent-only vertices. Will not include shared vertices in non-indexed strips, unless pre-empted. Increments even if VS Function Enable is DISABLED.</p>
<p>HSInvocations = # of patches executed by HS.</p>	<p>HS maintains HS_INVOCATION_COUNT. This gets incremented by 1 for each patch whenever HS is enabled.</p>
<p>DSInvocations = # of times DS is executed to shade a domain point. Allows HW to shade identical domain points multiple times, with the exception of point outputs where only unique domain points can be generated.</p>	<p>DS maintains DS_INVOCATION_COUNT. This is incremented for each domain point passed to a DS thread.</p>
<p>GSInvocations = # of times GS is executed. Obviously does not include partial primitives. May be incremented when StreamOut enabled, even if NULL_GS.</p>	<p>GS maintains GS_INVOCATION_COUNT, incrementing it by GSInvocations Increment Value for each dispatched instance. Will not be incremented if NULL_GS.</p>
<p>GSPrimitives = # of primitives GS generated. Does not include primitives passing through a disabled GS stage. May or may</p>	<p>GS maintains GS_PRIMITIVE_COUNT. GS unit will increment this as it parses the GS thread output.</p>



API-level Statistic	HW Support
not include partial primitives output by GS.	Will <i>not</i> include partial primitives output by GS threads.
NumPrimitivesWritten [<stream#>] = # of complete primitives written to the stream's SO buffer, subject to buffer overflow.	SOL maintains SO_NUM_PRIMS_WRITTEN[0-3] .
PrimitiveStorageNeeded [<stream#>] = # of complete primitives which would have been written to the stream's SO buffer ignoring any overflow.	SOL maintains SO_PRIM_STORAGE_NEEDED[0-3] .
CLInvocations = # of primitives <i>entering</i> rasterization (which starts with the clipper) and isn't affected by any actual clipping. Does not increment when rasterization is disabled (e.g., when StreamOut is the last enabled stage). May or may not include partial primitives.	CL OSB maintains CL_INVOCATION_COUNT . Will not include partial primitives. Note that the SOL (regardless of SO enabled) will discard primitives if rendering is disabled, so these primitives will not reach the CL unit.
CPimitives = # of primitives output from clipper. I.e., doesn't increment if TrivReject or dropped due to NaNs, increments by 1 if TrivAccept, or increments by number of primitives generated if MustClip. Does not increment when rasterization is disabled. May or may not include partial primitives. Accommodates infinite or no guardband.	SF OSB maintains CL_PRIMITIVES_COUNT . Will not include partial primitives.
PSInvocations = # of times PS is executed, including unlit "helper pixels" within a subspan that need to go through the PS shader to provide 2x2 gradients. Accommodates early depth/stencil. Does not increment if NULL PS. Multisampling: counts pixels shaded if PERPIXEL or samples shaded if PERSAMPLE.	WIZ maintains PS_INVOCATION_COUNT .
Occlusion = # of "visible" multisamples which passed both depth and stencil testing. Doesn't include PS-discarded pixels or oMask/AlphaToCoverage-killed samples. Both (a) a disabled test (depth or stencil) and (b) no bound RT or Depth/Stencil buffer conditions count as always passing.	WIZ & PBE maintain PS_DEPTH_COUNT .



3D Pipeline Geometry

Block Diagram

The following block diagram shows the stages of the Geometry Pipeline and where they are positioned in the overall 3D Pipeline.

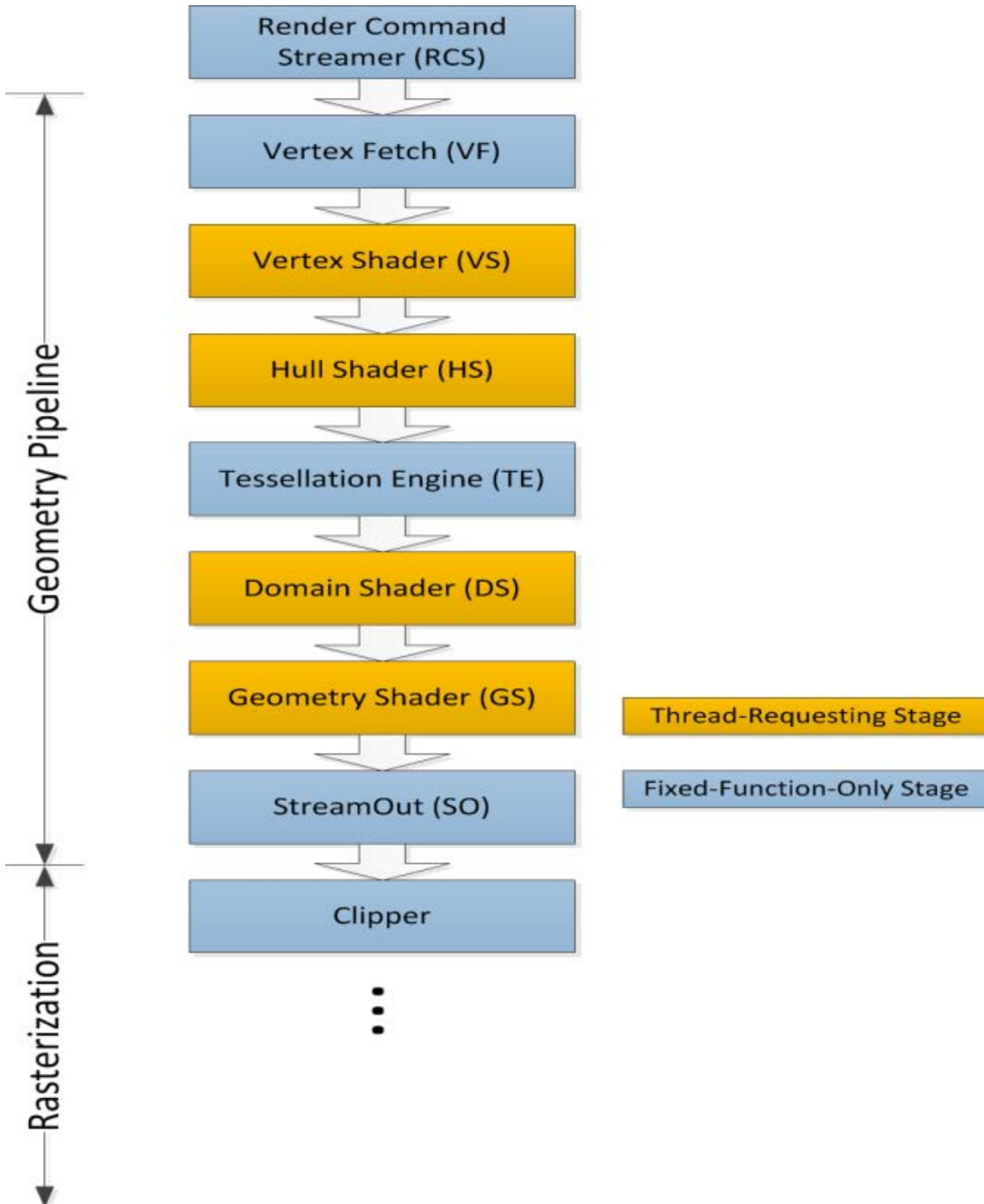



3D Primitives Overview

The 3DPRIMITIVE command (defined in the VF Stage chapter) is used to submit 3D primitives to be processed by the 3D pipeline. Typically the processing results in the rendering of pixel data into the render targets, but this is not required.

Terminology Note: There is considerable confusion surrounding the term *primitive*, e.g., is a triangle strip a *primitive*, or is a triangle within a triangle strip a *primitive*?

In this spec, we will try to avoid ambiguity by using the term *object* to represent the basic shapes (point, line, triangle), and *topology* to represent input geometry (strips, lists, etc.). Unfortunately, terms like '3DPRIMITIVE' must remain for legacy reasons.

The following table describes the basic primitive topology types supported in the 3D pipeline.

Notes:

- There are several variants of the basic topologies. These have been introduced to allow slight variations in behavior without requiring a state change.
- Number of vertices and Dangling Vertices: Topologies have an "expected" number of vertices in order to form complete objects within the topologies (e.g., LINELIST is expected to have an even number of vertices). The actual number of vertices specified in the 3DPRIMITIVE command, and as output from the GS unit, is allowed to deviate from this expected number, in which case any "dangling" vertices are discarded. The removal of dangling vertices is initially performed in the VF unit. To filter out dangling vertices emitted by GS threads, the CLIP unit also performs dangling-vertex removal at its input.

3D Primitive Topology Types

3D Primitive Topology Type (ordered alphabetically)	Description	Project	Security
QUADLIST	<p>A list of independent quad objects (4 vertices per quad).</p> <p>The QUADLIST topology is converted to POLYGON topology at the beginning of the 3D pipeline.</p> <p>Programming Restrictions:</p> <p>Normal usage expects a multiple of 4 vertices, though incomplete objects are silently ignored.</p>		
QUADSTRIP	<p>A list of vertices connected such that, after the first two vertices, each additional pair of vertices are associated with the previous two vertices to define a connected quad</p>		



3D Primitive Topology Type (ordered alphabetically)	Description	Project	Security
	<p>object.</p> <p>Programming Restrictions:</p> <p>Normal usage expects an even number (4 or greater) of vertices, though incomplete objects are silently ignored.</p>		
RECTLIST	<p>A list of independent rectangles, where only 3 vertices are provided per rectangle object, with the fourth vertex implied by the definition of a rectangle. V0=LowerRight, V1=LowerLeft, V2=UpperLeft. Implied V3 = V0-V1+V2.</p> <p>Programming Restrictions:</p> <p>Normal usage expects a multiple of 3 vertices, though incomplete objects are silently ignored.</p> <p>The RECTLIST primitive is supported specifically for 2D operations (e.g., BLTs and "stretch" BLTs) and not as a general 3D primitive. Due to this, a number of restrictions apply to the use of RECTLIST:</p> <p>Must utilize "screen space" coordinates (VPOS_SCREENSPACE) when the primitive reaches the CLIP stage. The W component of position must be 1.0 for all vertices. The 3 vertices of each object should specify a screen-aligned rectangle (after the implied vertex is computed).</p> <p>Clipping: Must not require clipping or rely on the CLIP unit's ClipTest logic to determine if clipping is required. Either the CLIP unit should be DISABLED, or the CLIP unit's Clip Mode should be set to a value other than CLIPMODE_NORMAL.</p> <p>Viewport Mapping must be DISABLED (as is typical with the use of screen-space coordinates).</p>		
TRIFAN	<p>Triangle objects arranged in a fan (or polygon). The initial vertex is maintained as a common vertex. After the second vertex, each additional vertex is associated with the previous vertex and the common vertex to define a connected triangle object.</p> <p>Programming Restrictions:</p> <p>Normal usage expects at least 3 vertices, though incomplete objects are silently ignored.</p>		
TRIFAN_NO STIPPLE	<p>Similar to TRIFAN, but polygon stipple is not applied (even if enabled).</p> <p>This can be used to support "point" polygon fill mode, under the combination of the following conditions:</p>		



3D Primitive Topology Type (ordered alphabetically)	Description	Project	Security
	<p>(a) when the frontfacing and backfacing polygon fill modes are different (so the final fill mode is not known to the driver),</p> <p>(b) one of the fill modes is "point" and the other is "solid",</p> <p>(c) point mode is being emulated by converting the point into a trifan,</p> <p>(d) polygon stipple is enabled. In this case, polygon stipple should not be applied to the points-emulated-as-trifans.</p>		
TRILIST	<p>A list of independent triangle objects (3 vertices per triangle).</p> <p>Programming Restrictions:</p> <p>Normal usage expects a multiple of 3 vertices, though incomplete objects are silently ignored.</p>		
TRILIST_ADJ	<p>A list of independent triangle objects with adjacency information (6 vertices per triangle).</p> <p>Programming Restrictions:</p> <p>Normal usage expects a multiple of 6 vertices, though incomplete objects are silently ignored.</p> <p>Not valid as output from GS thread.</p>		
TRISTRIP	<p>A list of vertices connected such that, after the first two vertices, each additional vertex is associated with the last two vertices to define a connected triangle object.</p> <p>Programming Restrictions:</p> <p>Normal usage expects at least 3 vertices, though incomplete objects are silently ignored.</p>		
TRISTRIP_ADJ	<p>A list of vertices where the even-numbered (including 0th) vertices are connected such that, after the first two vertex pairs, each additional even-numbered vertex is associated with the last two even-numbered vertices to define a connected triangle object. The odd-numbered vertices are adjacent-only vertices.</p> <p>Programming Restrictions:</p> <p>Normal usage expects at least 6 vertices, though incomplete objects are silently ignored.</p> <p>Not valid as output from GS thread.</p>		



3D Primitive Topology Type (ordered alphabetically)	Description	Project	Security				
TRISTRIP_REVERSE	Similar to TRISTRIP, though the sense of orientation (winding order) is reversed – this allows SW to break long tristrrips into smaller pieces and still maintain correct face orientations.						
PATCHLIST_n	<table border="1" data-bbox="293 632 1304 835"> <tr> <td data-bbox="293 632 1101 680">Project:</td> <td data-bbox="1101 632 1304 680">HSW</td> </tr> <tr> <td colspan="2" data-bbox="293 680 1304 835">List of n-vertex "patch" objects. These topologies cannot be rendered directly – the tessellation units must be used to convert them into points, lines, or triangles to produce rasterization results. (VS, GS, and StreamOutput operations can also be performed.)</td> </tr> </table>	Project:	HSW	List of n-vertex "patch" objects. These topologies cannot be rendered directly – the tessellation units must be used to convert them into points, lines, or triangles to produce rasterization results. (VS, GS, and StreamOutput operations can also be performed.)			
Project:	HSW						
List of n-vertex "patch" objects. These topologies cannot be rendered directly – the tessellation units must be used to convert them into points, lines, or triangles to produce rasterization results. (VS, GS, and StreamOutput operations can also be performed.)							

The following diagrams illustrate the basic 3D primitive topologies. (Variants are not shown if they have the same definition with respect to the information provided in the diagrams).

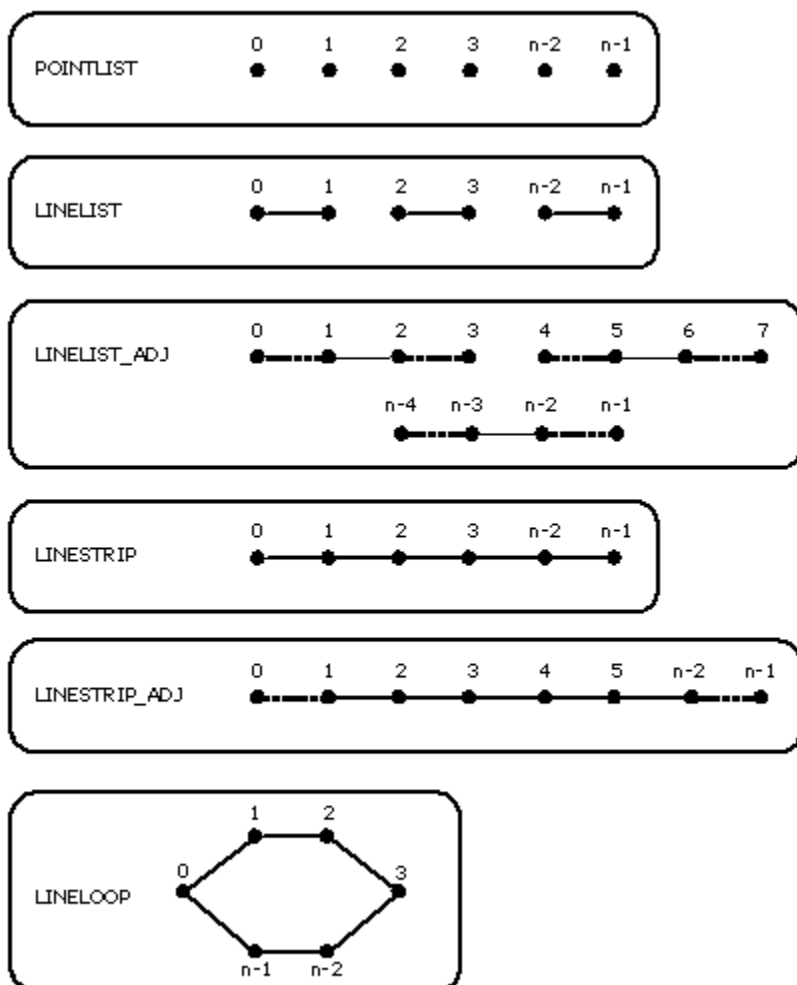

B6815-01

A note on the arrows you see below: These arrows are intended to show the vertex ordering of triangles that are to be considered having "clockwise" winding order in screen space. Effectively, the arrows show the order in which vertices are used in the cross-product (area, determinant) computation. Note that for TRISTRIP, this requires that either the order of odd-numbered triangles be reversed in the cross-product or the sign of the result of the normally-ordered cross-product be flipped (these are identical operations).



TRILIST



TRILIST_ADJ

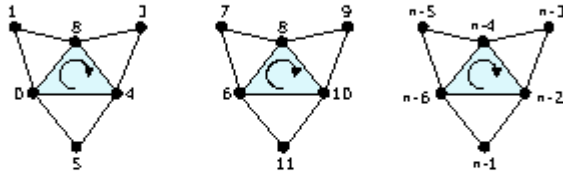

TRISTRIP

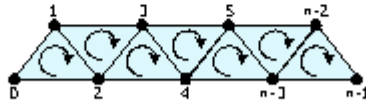

TRISTRIP_REVERSE

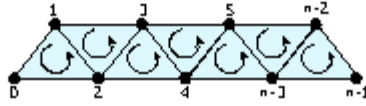

TRISTRIP_ADJ

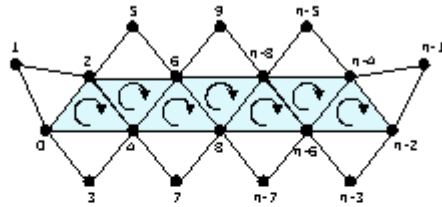

TRIFAN
POLYGON

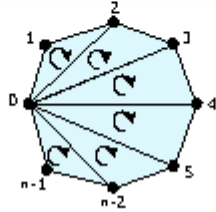

B6816-01

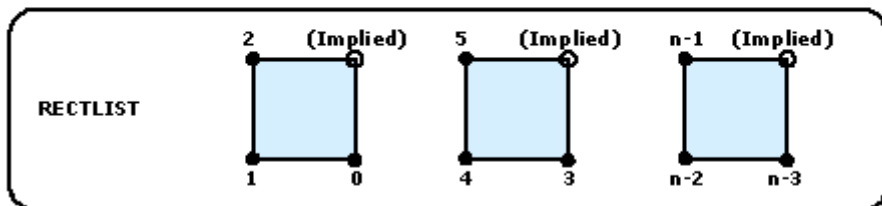
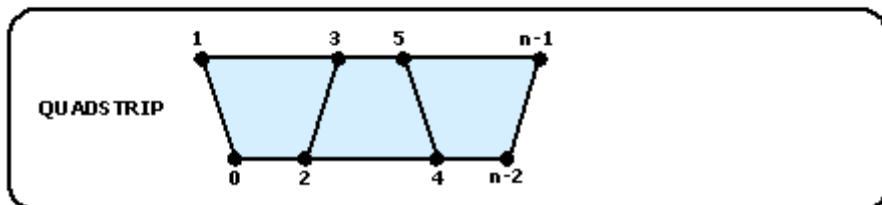
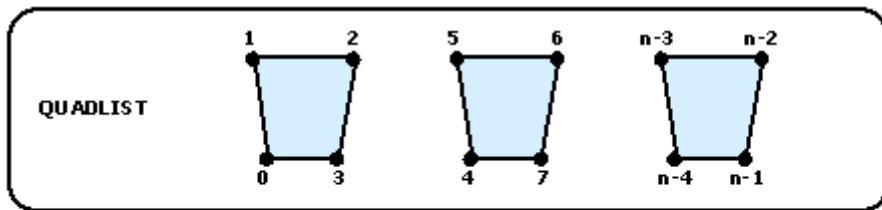

B6818-01



Vertex Data Overview

The 3D pipeline FF stages (past VF) receive input 3D primitives as a stream of vertex information packets. (These packets are not directly visible to software.) Much of the data associated with a vertex is passed indirectly via a VUE handle. The information provided in vertex packets includes:

- The **URB Handle** of the VUE: This is used by the FF unit to refer to the VUE and perform any required operations on it (e.g., cause it to be read into the thread payload, dereference it, etc.).
- **Primitive Topology Information:** This information is used to identify/delineate primitive topologies in the 3D pipeline. Initially, the VF unit supplies this information, which then passes through the VS stage unchanged. GS and CLIP threads must supply this information with each vertex they produce (via the URB_WRITE message). If a FF unit directly outputs vertices (that were not generated by a thread they spawned), that FF unit is responsible for providing this information.
 - **PrimType:** The type of topology, as defined by the corresponding field of the 3DPRIMITIVE command.
 - **StartPrim:** TRUE only for the first vertex of a topology.
 - **EndPrim:** TRUE only for the last vertex of a topology.
- (Possibly, depending on FF unit) Data read back from the **Vertex Header** of the VUE.

Vertex URB Entry (VUE) Formats

In general, vertex data is stored in Vertex URB Entries (VUEs) in the URB, processed by CLIP threads, and only referenced by the pipeline stages indirectly via VUE handles. Therefore (for the most part) the contents/format of the vertex data is not exposed to 3D pipeline hardware – the FF units are typically only aware of the handles and sizes of VUEs.

VUEs are written in two ways:

- At the top of the 3D Geometry pipeline, the VF's InputAssembly function creates VUEs and initializes them from data extracted from Vertex Buffers as well as internally-generated data.
- VS, GS, and CLIP threads can compute, format, and write new VUEs as thread output.

There are only two points in the 3D FF pipeline where the FF units are exposed to the VUE data. Otherwise the VUE remains opaque to the 3D pipeline hardware.

- Just prior to the CLIP stage, all VUEs are read-back: Optional readback of ClipDistance values (up to 8 floats in an aligned 256-bit URB row).
- Just after the CLIP stage, on clip-generated VUEs are read-back: Readback of the Vertex Header (first 256 bits of the VUE).

Software must ensure that any VUEs subject to readback by the 3D pipeline start with a valid Vertex Header. This extends to all VUEs with the following exceptions:



- If the VS function is enabled, the VF-written VUEs are not required to have Vertex Headers, as the VS-incoming vertices are guaranteed to be consumed by the VS (i.e., the VS thread is responsible for overwriting the input vertex data).
- If the GS FF is enabled, neither VF-written VUEs nor VS thread-generated VUEs are required to have Vertex Headers, as the GS will consume all incoming vertices.
- (There is a pathological case where the CLIP state can be programmed to guarantee that all CLIP-incoming vertices are consumed – regardless of the data read back prior to the CLIP stage – and therefore only the CLIP thread-generated vertices would require Vertex Headers.)

The following table defines the Vertex Header. The Position fields are described in further detail below.

VUE Vertex Header

DWord	Bits	Description
D0	31:0	Reserved: MBZ
D1	31:0	<p>Render Target Array Index (RTAIndex). This value is (eventually) used to index into a specific element of an <i>array</i> Render Target. It is read back by the GS unit (for all exiting vertices) and the Clip unit (for all clip-generated vertices), subsequently routed into the PS thread payload, and eventually included in the RTWrite DataPort message header for use by the DataPort shared function.</p> <p>Software is responsible for ensuring this field is zero whenever a programmable index value is not required. When a programmable index value is required, software must ensure that the correct 11-bit value is written to this field. Specifically, the kernels must perform a reange check of computed index values against [0,2047], and output zero if that range is exceeded. Note that the unmodified <i>renderTargetArrayIndex</i> must be maintained in the VUE outside of the Vertex Header.</p> <p>Software can force an RTAIndex of 0 to be used (effectively ignoring the setting of this DWord) by use of the ForceZeroRTAIndex bit (3DSTATE_CLIP). Otherwise the read-back value will be used to select an RTArray element, after being clamped to the RTArray surface's [MinimumArrayElement, Depth] range (SURFACE_STATE).</p> <p>Format: 0-based U32 index value</p>
D2	31:0	<p>Viewport Index. This value is used to select one of a possible 16 sets of viewport (VP) state parameters in the Clip unit's VertexClipTest function and in the SF unit's ViewportMapping and Scissor functions.</p> <p>The GS unit (even if disabled) will read back this value for all vertices exiting the GS stage and entering the Clip stage. When enabled, the GS unit will range-check the value against [0,Maximum VPIndex] (see GS_STATE, CLIP_STATE). After this range-check the values are sent down the pipeline and used in the Clip unit's VertexClipTest function. For vertices passing through the Clip stage, these values will also be sent to the SF unit for use in ViewportMapping and Scissor functions.</p> <p>The Clip unit (if enabled) will read back this value only for vertices generated by CLIP threads. The Clip unit will perform a range clamp similar to the GS unit.</p> <p>Software can force a value of 0 to be used by programming Maximum VPIndex to 0.</p> <p>Format: 0-based U32 index value</p>



DWord	Bits	Description
D3	31:0	<p>Point Width. This field specifies the width of POINT objects in screen-space pixels. It is used only for vertices within POINTLIST and POINTLIST_BF primitive topologies, and is ignored for vertices associated with other primitive topologies.</p> <p>This field is read back by both the GS and Clip units.</p> <p>Format: FLOAT32</p>
D4	31:0	<p>Vertex Position X Coordinate. This field contains the X component of the vertex's 4D space position.</p> <p>Format: FLOAT32</p>
D5	31:0	<p>Vertex Position Y Coordinate. This field contains the Y component of the vertex's 4D space position</p> <p>Format: FLOAT32</p>
D6	31:0	<p>Vertex Position Z Coordinate. This field contains the Z component of the vertex's NDC space position</p> <p>Format: FLOAT32</p>
D7	31:0	<p>Vertex Position W Coordinate. This field contains the Z component of the vertex's 4D space position</p> <p>Format: FLOAT32</p>
D8	31:0	<p>ClipDistance 0 Value (optional). If the UserClipDistance Clip Test Enable Bitmask bit (3DSTATE_CLIP) is set, this value will be read from the URB in the Clip stage. If the value is found to be less than 0 or a NaN, the vertex's UCF<0> bit will set in the Clip unit's VertexClipTest function.</p> <p>If the UserClipDistance Clip Test Enable Bitmask bit is clear, this value will not be read back, and the vertex's UCF<0> bit will be zero by definition.</p> <p>Format: FLOAT32</p>
D9	31:0	ClipDistance 1 Value (optional). See above
D10	31:0	ClipDistance 2 Value (optional). See above
D11	31:0	ClipDistance 3 Value (optional). See above
D12	31:0	ClipDistance 4 Value (optional). See above
D13	31:0	ClipDistance 5 Value (optional). See above
D14	31:0	ClipDistance 6 Value (optional). See above



DWord	Bits	Description
D15	31:0	ClipDistance 7 Value (optional). See above
	31:0	(Remainder of Vertex Elements). The absolute maximum size limit on this data is specified via a maximum limit on the amount of data that can be read from a VUE (including the Vertex Header) (Vertex Entry URB Read Length has a maximum value of 63 256-bit units). Therefore the Remainder of Vertex Elements has an absolute maximum size of 62 256-bit units. Of course the actual allocated size of the VUE can and will limit the amount of data in a VUE.

Vertex Positions

(For brevity, the following discussion uses the term map as a shorthand for "compute screen space coordinate via perspective divide followed by viewport transform".)

The "Position" fields of the Vertex Header are the only vertex position coordinates exposed to the 3D Pipeline. The CLIP and SF units are the only FF units which perform operations using these positions. The VUE will likely contain other position attributes for the vertex outside of the Vertex Header, though this information is not directly exposed to the FF units. For example, the Clip Space position will likely be required in the VUE (outside of the Vertex Header) to perform correct and robust 3D Clipping in the CLIP thread.

In the CLIP unit, the read-back Position fields are interpreted as being in one of two coordinate systems, depending on the **CLIP_STATE.VertexPositionSpace** bit. The CLIP unit modifies its VertexClipTest function depending on the coordinate space of the incoming vertices.

VPOS_CLIPSPACE (Homogeneous 4D Clip-space coordinates, pre-perspective division): The Clip Space position is defined in a homogeneous 4D coordinate space (pre-perspective divide), where the visible "view volume" is defined by the APIs. The API's VS or GS shader program will include geometric transforms in the computation of this clip space position such that the resulting coordinate is positioned properly in relation to the view volume (i.e., it will include a "view transform" in this computation path). When this coordinate system is selected, the 3D FF pipeline will perform a perspective projection (division of x,y,z by w), perform clip-test on the resulting NDC (Normalized Device Coordinates), and eventually perform viewport mapping (in the SF unit) to yield screen-space (pixel) coordinates.

VPOS_SCREENSPACE (Screen Space position): Under certain circumstances, the position in the Vertex Header will contain the screen-space (pixel) coordinates (post viewport mapping).

The SF unit does *not* have a state bit defining the coordinate space of the incoming vertex positions. Software must use the Viewport Mapping function of the SF unit in order to ensure that screen-space coordinates are available after that function. If screen space coordinates are passed into SF, then software will likely turn off the Viewport Mapping function.

The following subsections briefly describe the three relevant coordinate spaces.



Clip Space Position

The *clip-space* position of a vertex is defined in a homogeneous 4D coordinate space where, after perspective projection (division by W), the visible *view volume* is some canonical (3D) cuboid. Typically the X/Y extents of this cuboid are [-1,+1], while the Z extents are either [-1,+1] or [0,+1]. The API's VS or GS shader program will include geometric transforms in the computation of this clip space position such that the resulting coordinate is positioned properly in relation to the view volume (i.e., it will include a *view transform* in this computation path).

Note that, under typical perspective projections, the clip-space W coordinate is equal to the view-space Z coordinate.

A vertex's clip-space coordinates must be maintained in the VUE up to 3D clipping, as this clipping is performed in clip space.

In vertex clip-space positions must be included in the Vertex Header, so that they can be read-back (prior to Clipping) and then subjected to perspective projection (in hardware) and subsequent use by the FF pipeline.

NDC Space Position

A perspective divide operation performed on a clip-space position yields a [X,Y,Z,RHW] NDC (Normalized Device Coordinates) space position. Here *normalized* means that visible geometry is located within the [-1,+1] or [0,+1] extent view volume cuboid (see clip-space above).

- The NDC X,Y,Z coordinates are the clip-space X,Y,Z coordinates (respectively) divided by the clip-space W coordinate (or, more correctly, the clip-space X,Y,Z coordinates are multiplied by the reciprocal of the clip space W coordinate).
 - Note that the X,Y,Z coordinates may contain INFINITY or NaN values (see below).
- The NDC RHW coordinate is the reciprocal of the clip-space W coordinate and therefore, under normal perspective projections, it is the reciprocal of the view-space Z coordinate. Note that NDC space is really a 3D coordinate space, where this RHW coordinate is retained in order to perform perspective-correct interpolation, etal. Note that, under typical perspective projections.
 - Note that the RHW coordinate make contain an INFINITY or NaN value (see below).

Screen-Space Position

Screen-space coordinates are defined as:

- X,Y coordinates are in absolute screen space (pixel coordinates, upper left origin). See Vertex X,Y Clamping and Quantization in the SF section for a discussion of the limitations/restrictions placed on screenspace X,Y coordinates.
- Z coordinate has been mapped into the range used for DepthTest.
- RHW coordinate is actually the reciprocal of clip-space W coordinate (typically the reciprocal of the view-space Z coordinate).



3D Pipeline – Vertex Fetch (VF) Stage

Vertex Fetch (VF) Stage Overview

The VF stage performs one major function: executing 3DPRIMITIVE commands. This is handled by the VF's InputAssembly function.

The following subsections describe some high-level concepts associated with the VF stage.

State

This section contains various state registers.

Control State

3DSTATE_VF

Index Buffer (IB) State

The 3DSTATE_INDEX_BUFFER command is used to define an *Index Buffer* (IB) used in subsequent 3DPRIMITIVE commands.

The RANDOM access mode of the 3DPRIMITIVE command involves the use of a memory-resident IB. The IB, defined via the 3DSTATE_INDEX_BUFFER command described below, contains a 1D array of 8, 16 or 32-bit index values. These index values will be fetched by the InputAssembly function, and subsequently used to compute locations in VERTEXDATA buffers from which the actual vertex data is to be fetched. (This is opposed to the SEQUENTIAL access mode where the vertex data is simply fetched sequentially from the buffers).

Project:	HSW
Software is responsible for ensuring that accesses outside the IB do not occur. This is possible as software can compute the range of IB values referenced by a 3DPRIMITIVE command (knowing the StartVertexLocation , InstanceCount , and VerticesPerInstance values) and can then compare this range to the IB extent.	

3DSTATE_INDEX_BUFFER

3DSTATE_INDEX_BUFFER

The following table lists which primitive topology types support the presence of Cut Indices.

Project	Description
HSW	When 3DSTATE_VF has Cut Index Enable set, it is UNDEFINED to issue a 3DPRIMITIVE with a primitive topology type not supporting a Cut Index (even if no cut indices are actually present in the index buffer).



Definition	Cut Index?	
3DPRIM_POINTLIST	Y	
3DPRIM_LINELIST	Y	
3DPRIM_LINESTRIP	Y	
3DPRIM_TRILIST	Y	
3DPRIM_TRISTRIP	Y	
3DPRIM_TRIFAN	Project	Cut Index?
	HSW	Y
3DPRIM_QUADLIST	Project	Cut Index?
	HSW	Y
3DPRIM_QUADSTRIP	Project	Cut Index?
	HSW	Y
3DPRIM_LINELIST_ADJ	Y	
3DPRIM_LINESTRIP_ADJ	Y	
3DPRIM_TRILIST_ADJ	Y	
3DPRIM_TRISTRIP_ADJ	Y	
3DPRIM_TRISTRIP_REVERSE	Y	
3DPRIM_POLYGON	Project	Cut Index?
	HSW	Y
3DPRIM_RECTLIST	N	
3DPRIM_LINELOOP	Project	Cut Index?
	HSW	Y
3DPRIM_POINTLIST_BF	Y	
3DPRIM_LINESTRIP_CONT	Y	
3DPRIM_LINESTRIP_BF	Y	
3DPRIM_LINESTRIP_CONT_BF	Y	
3DPRIM_TRIFAN_NOSTIPPLE	N	
3DPRIM_PATCHLIST_n	Project	Cut Index?
	HSW	Y



Vertex Buffers (VB) State

The 3DSTATE_VERTEX_BUFFERS and 3DSTATE_INSTANCE_STEP_RATE commands are used to define *Vertex Buffers* (VBs) used in subsequent 3DPRIMITIVE commands.

Most input vertex data is sourced from memory-resident VBs. A VB is a 1D array of structures, where the size of the structure as defined by the VB's **BufferPitch**. VBs are accessed either as *VERTEXDATA buffers* or *INSTANCEDATA buffers*, as defined by the VB's **BufferAccessType**. The VB's access type will determine whether the VF-computed VertexIndex or InstanceIndex is used to access data in the VB.

Given that the RANDOM access mode of the 3DPRIMITIVE command utilizes an IB (possibly provided by an application) to compute VB index values, VB definitions contain a **MaxIndex** value used to detect accesses beyond the end of the VBs. Any access outside the extent of a VB returns 0.

3DSTATE_VERTEX_BUFFERS

VERTEX_BUFFER_STATE

VERTEXDATA Buffers – SEQUENTIAL Access

Project	Description
HSW	Instead of "VBState.StartingBufferAddress + VBState.MaxIndex x VBState.BufferPitch", the address of the byte immediately beyond the last valid byte of the buffer is determined by "VBState.EndAddress + 1".

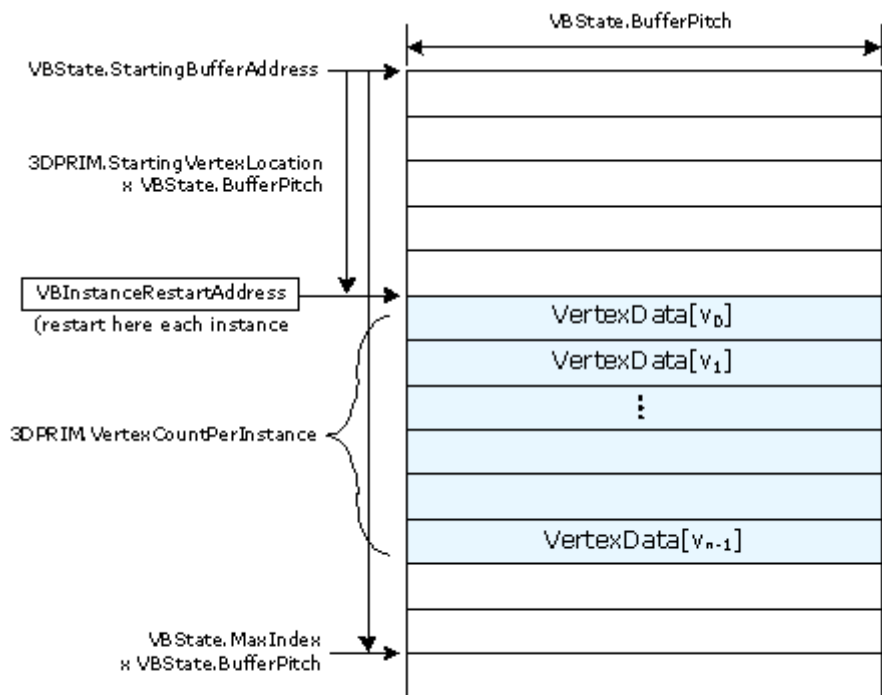

B6826-01



VERTEXDATA Buffers – RANDOM Access

Project	Description
HSW	Instead of " $\text{VBState.StartingBufferAddress} + \text{VBState.MaxIndex} \times \text{VBState.BufferPitch}$ ", the address of the byte immediately beyond the last valid byte of the buffer is determined by " $\text{VBState.EndAddress} + 1$ ".

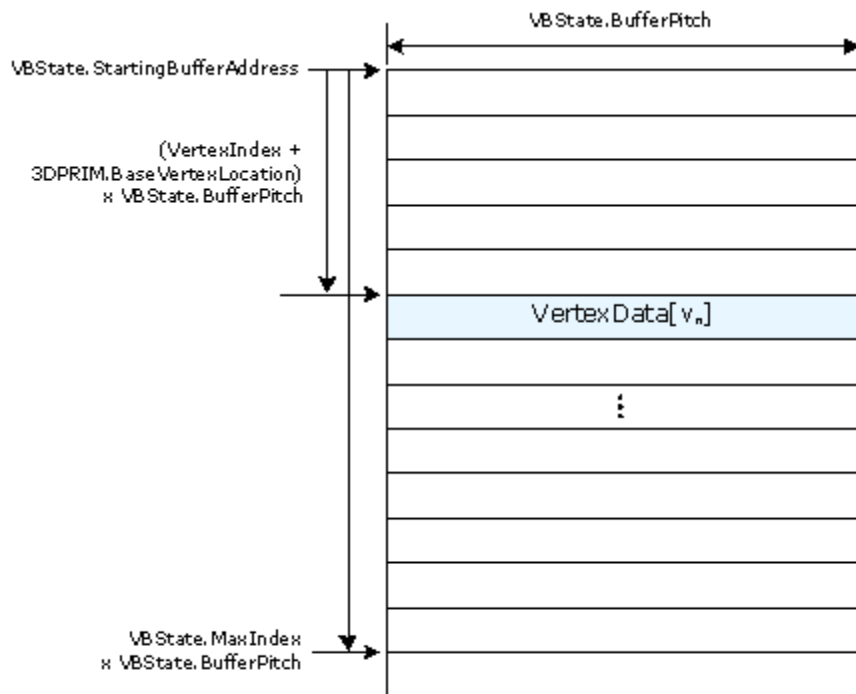

B6827-01

INSTANCEDATA Buffers

Project	Description
HSW	Instead of " $\text{VBState.StartingBufferAddress} + \text{VBState.MaxIndex} \times \text{VBState.BufferPitch}$ ", the address of the byte immediately beyond the last valid byte of the buffer is determined by " $\text{VBState.EndAddress} + 1$ ".

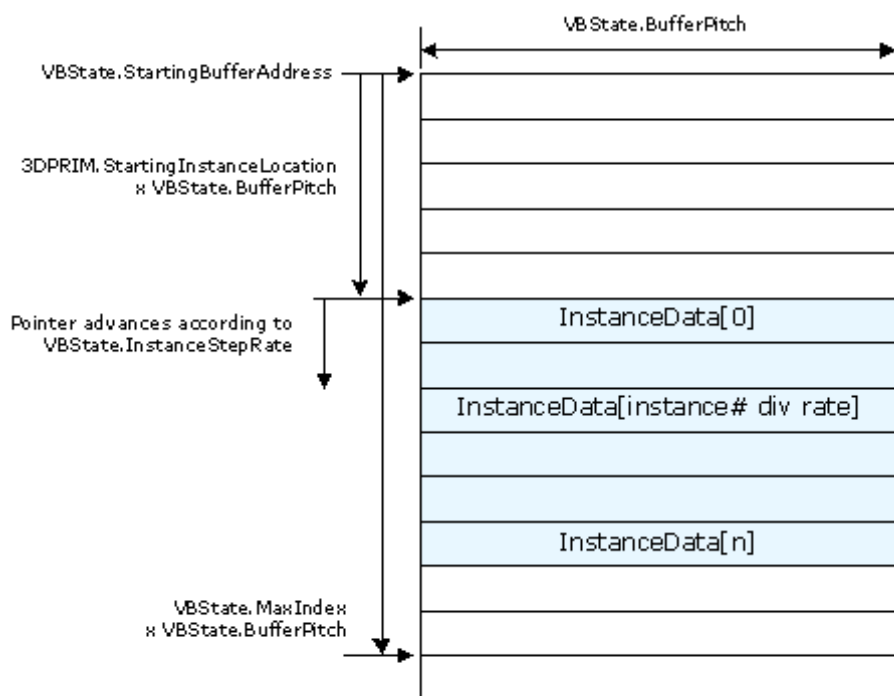

B6839-01

Vertex Definition State

The following subsections define the state information for vertex data and describe some related processing.

Input Vertex Definition

The `3DSTATE_VERTEX_ELEMENTS` command is used to define the source and format of input vertex data and the format of how it is stored in the destination VUE as part of `3DPRIMITIVE` processing in the VF unit.

Refer to *3DPRIMITIVE Processing* below for the general flow of how input vertices are input and stored during processing of the `3DPRIMITIVE` command.

VERTEX_ELEMENT_STATE

3DSTATE_VERTEX_ELEMENTS

3D_VertexComponentControl

Vertex Fetch State Preprocessing Extension

After creation of this topic is approved, will move the content for Vertex Fetch State Preprocessing Extension into it.



3D Primitive Command

Following are 3D Primitive Commands:

3DPRIMITIVE

3D Primitive Topology Type Encoding

The following table defines the encoding of the Primitive Topology Type field. See *3D Pipeline* for details, programming restrictions, diagrams, and a discussion of the basic primitive types.

3D_PrimTopoType

Functions

This section covers the various functions for Vertex Fetch.

Input Assembly

The VF's InputAssembly function includes (for each vertex generated):

- Generation of VertexIndex and InstanceIndex for each vertex, possibly via use of an Index Buffer.
- Lookup of the VertexIndex in the Vertex Cache (if enabled)
- If a cache miss is detected:
 - Use of computed indices to fetch data from memory-resident vertex buffers
 - Format conversion of the fetched vertex data
 - Assembly of the format conversion results (and possibly some internally generated data) to form the complete "input" (raw) vertex
 - Storing the input vertex data in a Vertex URB Entry (VUE) in the URB
 - Output of the VUE handle of the input vertex to the VS stage
- If a cache hit is detected, the VUE handle from the Vertex Cache is passed to the VS stage (marked as a cache hit to prevent any VS processing).

Vertex Assembly

The VF utilizes a number of VERTEX_ELEMENT state structures to define the contents and format of the vertex data to be stored in Vertex URB Entries (VUEs) in the URB. See below for a detailed description of the command used to define these structures (3DSTATE_VERTEX_ELEMENTS).

Each active VERTEX_ELEMENT structure defines up to 4 contiguous DWords of VUE data, where each DWord is considered a "component" of the vertex element. The starting destination DWord offset of the vertex element in the VUE is specified, and the VERTEX_ELEMENT structures must be defined with monotonically increasing VUE offsets. For each component, the source of the component is specified. The source may be a constant (0, 0x1, or 1.0f), a generated ID (VertexID, InstanceID or PrimitiveID), or a component of a structure in memory (e.g., the Y component of an XYZW position in memory). In the case



of a memory source, the Vertex Buffer sourcing the data, and the location and format of the source data with that VB are specified.

The VF's Vertex Assembly process can be envisioned as the VF unit stepping through the VERTEX_ELEMENT structures in order, fetching and format-converting the source information (if memory resident), and storing the results in the destination VUE.

The VF stage communicates with the VS stage in order to implement a Vertex Cache function in the 3D pipeline. The Vertex Cache is strictly a performance-enhancing feature and has no impact on 3D pipeline results (other than a few statistics counters).

The Vertex Cache contains the VUE handles of VS-output (shaded) vertices if the VS function is enabled, and the VUE handles of VF-output (raw) vertices if the VS function is disabled. (Note that the actual vertex data is held in the URB, and only the handles of the vertices are stored in the cache). In either case, the contents of the cache (VUE handles) are tagged with the VertexIndex value used to fetch the input vertex data. The rationale for using the VertexIndex as the tag is that (assuming no other state or parameters change) a vertex with the same VertexIndex as a previous vertex will have the same input data, and therefore the same result from the VF+VS function.

Note that any change to the state controlling the InputAssembly function (e.g., vertex buffer definition), or any change to the state controlling the VS function (if enabled) (e.g., VS kernel), will result in the Vertex Cache being invalidated. In addition, any non-trivial use of instancing (i.e., more than one instance per 3DPRIMITIVE command and the inclusion of instance data in the input vertex) will effectively invalidate the cache between instances, as the InstanceIndex is not included in the cache tag. See Vertex Caching in *Vertex Shader* for more information on the Vertex Cache (e.g., when it is implicitly disabled, etc.)

Input Data: Push Model vs. Pull Model

Given the programmability of the pipeline, and the ability of shaders to input (load/sample) data from memory buffers in an arbitrary fashion, the decision arises in whether to push instance/vertex data into the front of the pipeline or defer the data access (pull) to the shaders that require it.

There are tradeoffs involved in deciding between these models. For vertex data, it is probably always better to push the data into the pipeline, as the VF hardware attempts to cover the latency of the data fetch. The decision is less clear for instance data, as pushing instance data leads to larger Vertex URB entries which will be holding redundant data (as the instance data for vertices of an object are by definition the same). Regardless, the GEN 3D pipeline supports both models.

Generated IDs

Note that the generated IDs are considered separate from any offset computations performed by the VF unit, and are therefore described separately here.

The VF generates InstanceID, VertexID, and PrimitiveID values as part of the InputAssembly process.

VertexID and InstanceID are only allowed to be inserted into the input vertex data as it is gathered and written into the URB as a VUE.



Project	Description
	It is only available to the GS and HS as a special non-vertex input and the PS as a constant-interpolated attribute. It is not seen by the VS or DS at all.

The PrimitiveID therefore is kept separate from the vertex data. Take for example a TRILIST primitive topology: It should be possible to share vertices between triangles in the list (i.e., reuse the VS output of a vertex), even though each triangle has a different PrimitiveID associated with it.

Project	Description
	The InstanceID, VertexID, and PrimitiveID values associated with each vertex can be stored in the vertex's VUE, via use of the Component <i>n</i> Control fields in the VERTEX_ELEMENT structure. This makes the values available to the VS thread.
	The PrimitiveID can no longer be stored in the VUE (see above). There is no API-specific reason to do so. The 32-bit PrimitiveIDs associated with objects are passed down the FF pipeline and made available to HS, DS, GS, and Setup threads as payload header data. A side effect of this feature is that the vertex cache can operate even when PrimitiveIDs are being used.

3D Primitive Processing

Functional Overview

The following pseudocode summarizes the general flow of 3D Primitive Processing.

```
CommandInit
  InstanceLoop {
    VertexLoop {
      VertexIndexGeneration
      if ( cutFlag )
        TerminatePrimitive
      else {
        OutputBufferedVertex
        VertexCacheLookup
        if ( miss ) {
          VertexElementLoop {
            SourceElementFetch
            FormatConversion
            DestinationComponentSelection
            PrimitiveInfoGeneration
            URBWrite
          }
        }
      }
    }
  }
  TerminatePrimitive
}
```

CommandInit

The InstanceID value is initialized to 0.



InstanceLoop

The InstanceLoop is the outmost loop, iterating through each instance of primitives. There is no special "non-instanced" mode – at a minimum there is one instance of primitives.

For SEQUENTIAL accessing, the VertexID value is initialized to 0 at the start of each instance. (For RANDOM accessing, there is no initial value for VertexID, as it is derived from the fetched IB value).

The PrimitiveID is also initialized to 0 at the start of each instance. StartPrim is initialized to TRUE.

The VertexLoop (see below) is then executed to iterate through the instance vertices and output vertices to the pipeline as required.

The end of each iteration of InstanceLoop includes an implied "cut" operation.

The InstanceID value is incremented at the end of each InstanceLoop. Note that each instance will produce the same vertex outputs with the exception of any data dependent on InstanceID (i.e., "instance data").

VertexLoop

The VertexLoop iterates VertexNumber through the VertexCountPerInstance vertices for the instance.

For each iteration, a number of processing steps are performed (see below) to generate the information that comprises a vertex. Note that, due to CutProcessing, each iteration does not necessarily output a vertex to the pipeline. When a vertex is to be output, the following information is generated for that vertex:

- PrimitiveType associated with the vertex. This is simply a copy of the PrimitiveTopologyType field of the 3DPRIMITIVE
- VUE handle at which the vertex data is stored:
 - For a Vertex Cache hit, the VUE handle is marked with a VCHit boolean, so that the VS unit will not attempt to process (shade) that vertex.
 - Otherwise, the VertexLoop will generate and store the input vertex data into the VUE referenced by this handle.
- The PrimitiveID associated with the vertex. See PrimitiveInfoGeneration.
- PrimStart and PrimEnd booleans associated with the vertex. See PrimitiveInfoGeneration.

(Note that a single vertex of buffering is required in order to associate PrimEnd with a vertex, as this information may not be known until the next iteration through the VertexLoop (see *OutputPrimitiveDelimiter*).

VertexNumber value is incremented by 1 at the end of the loop.

VertexIndexGeneration

A VertexIndex value needs to be derived for each vertex. With the exception of the "cut" index, this index value is used as the vertex cache tag and as a structure index into all VERTEXDATA VBs.



For SEQUENTIAL accessing, the VertexID and VertexIndex value is derived as shown below:

```
VertexIndex = StartVertexLocation + VertexNumber  
VertexID = VertexNumber
```

For RANDOM access, the VertexID and VertexIndex is derived from an IBValue read from the IB, as shown below:

```
IBIndex = StartVertexLocation + VertexNumber  
VertexID = IB[IBIndex]  
if ( CutIndexEnable && VertexID == CutIndex )  
    CutFlag = 1  
else  
    VertexIndex = VertexID + BaseVertexLocation  
    CutFlag = 0  
endif
```

Index Buffer Access

The following figure illustrates how the Index Buffer is accessed.

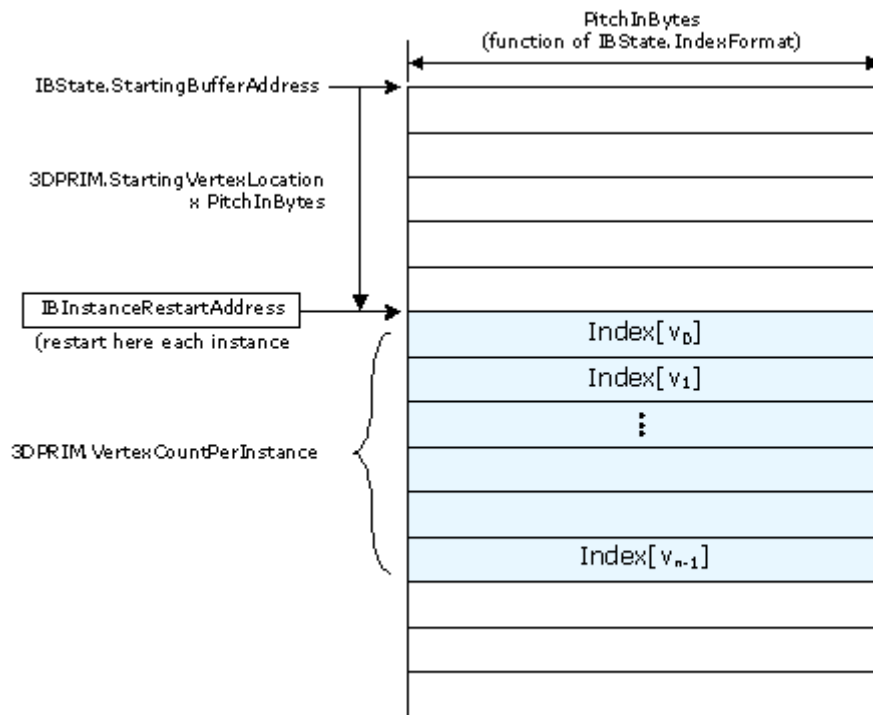

B.6825-01

TerminatePrimitive

For RANDOM accessing, and when enabled via **Cut Index Enable**, a fetched IBValue of 'all ones' (0xFF, 0xFFFF, or 0xFFFFFFFF depending on **Index Format**) is interpreted as a 'cut value' and signals the termination of the current primitive and the possible start of the next primitive. This allows the



application to specify an instance as a sequence of variable-sized strip primitives (though the cut value applies to any primitive type).

Also, there is an implied primitive termination at the end of each InstanceLoop (and so strip primitives cannot span multiple instances).

In either case, the currently-buffered vertex (if any) is marked with EndPrim and then flushed out to the pipeline.

The next-output vertex (if any) is marked with StartPrim.

Whenever a primitive delimiter is encountered, the PIDCounterS and PIDCounterR counters are reset to 0. These counters control the incrementing (in PrimitiveInfoGeneration, below) of PrimitiveID within each primitive topology of an instance.

```
if ( PIDCounterS != 0 ) // There is a buffered vertex
    if ( primType == TRISTRIP_ADJ )
        if ( PIDCounterS== 6 || PIDCounterR == 1 )
            PrimitiveID ++
        endif
    endif
    PrimEnd = TRUE
    OutputBufferedVertex
endif
PrimEnd = FALSE
PrimStart = TRUE
```

VertexCacheLookup

The VertexIndex value is used as the tag value for the VertexCache (see *Vertex Cache* above). If the Vertex Cache is enabled and the VertexIndex value hits in the cache, the VUE handle is read from the cache and inserted into the vertex stream. It is marked with a VCHit boolean to suppress processing (shading) in the VS unit.

Otherwise, for Vertex Cache misses, a VUE handle is obtained to provide storage for the generated vertex data. VertexLoop processing then proceeds to iterate through the VEs to generate the destination VUE data.

VertexElementLoop

The VertexElementLoop generates and stores vertex data in the destination VUE one VE at a time.

Vertex Element Data Path

The following diagram shows the path by which a vertex element within the destination VUE is generated and how the fields of the VERTEX_ELEMENT_STATE structure is used to control the generation.

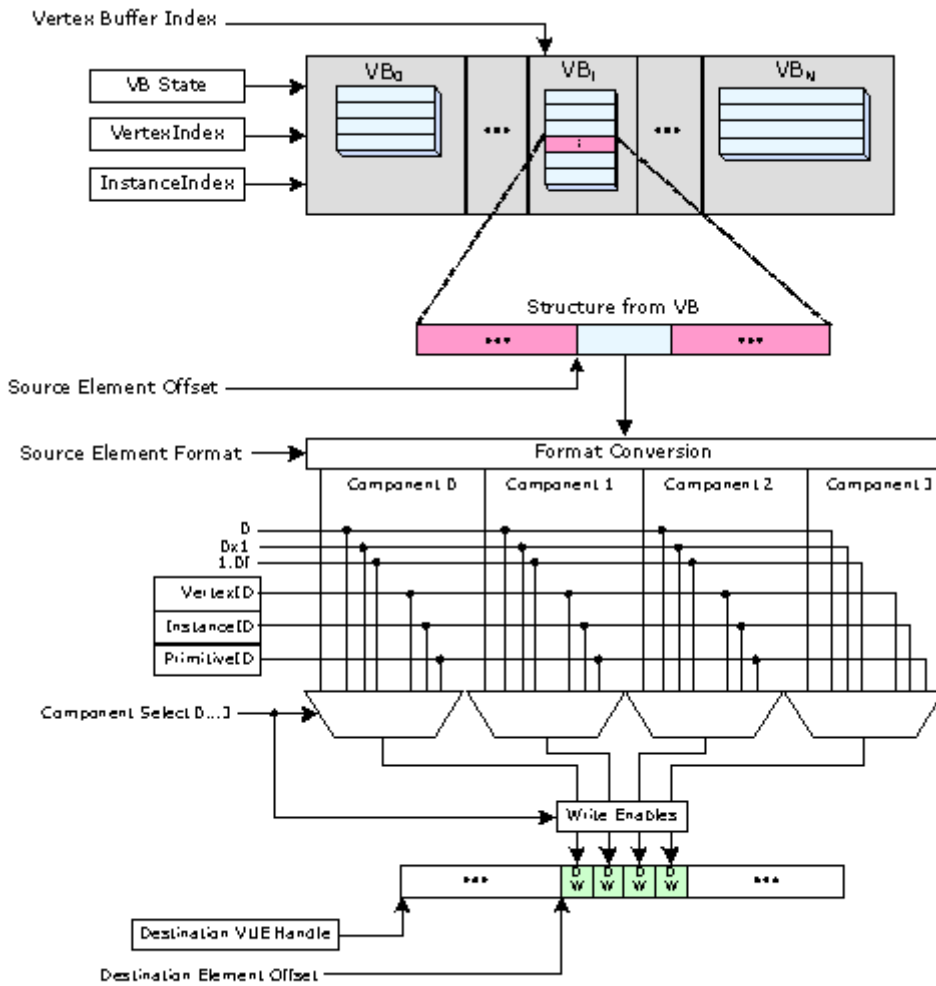

B6840-01

SourceElementFetch

The following assumes the VE requires data from a VB, which is the typical case. In the case that the VE is completely comprised of constant and/or auto-generated IDs, the SourceElementFetch and FormatConversion steps are skipped.

The structure index within the VE's selected VB is computed as follows:

```
if (VB is a VERTEXDATA VB)
    VBIndex = VertexIndex
else // INSTANCEDATA VB
    VBIndex = StartInstanceLocation
    if (VB.InstanceDataStepRate > 0)
        VBIndex += InstanceID/VB.InstanceDataStepRate
    endif
endif
```

If VBIndex is invalid (i.e., negative or past **Max Index**), the data returned from the VB fetch is defined to be zero. Otherwise, the address of the source data required for the VE is then computed and the data is read from the VB. The amount of data read from the VB is determined by the **Source Element Format**.



```

if ( (VBIndex < 0) || (VBIndex > VB.MaxIndex) )
    srcData = 0
else
    pSrcData = VB.BufferStartingAddress + (VBIndex * VB.BufferPitch) + VE.SourceElementOffset
    srcData = MemoryRead(pSrcData, VE.SourceElementFormat)
endif

```

FormatConversion

Once the VE source data has been fetched, it is subjected to format conversion. The output of format conversion is up to 4 32-bit components, each either integer or floating-point (as specified by the **Source Element Format**). See *Sampler* for conversion algorithms.

Project:

Note: If a 32 bit uscaled or sscaled format is used, then a float format needs to be used so VF will keep the data as is and the kernel needs to convert the format to 32 bit float.

The following table lists the valid **Source Element Format** selections, along with the format and availability of the converted components (if a component is listed as -, it cannot be used as the source of a VUE component). **Note:** This table is a subset of the list of supported surface formats defined in the *Sampler* chapter. Please refer to that table as the "master list". This table is here only to identify the components available (per format) and their format.

Source Element Formats Supported in VF Unit

Project	Source Element	Converted Component				
	Surface Format Name	Format	0	1	2	3
	R32G32B32A32_FLOAT	FLOAT	R	G	B	A
	R32G32B32A32_SINT	SINT	R	G	B	A
	R32G32B32A32_UINT	UINT	R	G	B	A
	R32G32B32A32_UNORM	FLOAT	R	G	B	A
	R32G32B32A32_SNORM	FLOAT	R	G	B	A
	R64G64_FLOAT	FLOAT	R	G	-	-
	R32G32B32A32_SSCALED	FLOAT	R	G	B	A
	R32G32B32A32_USCALED	FLOAT	R	G	B	A
HSW:B+	R32G32B32A32_SFIXED	FLOAT	R	G	B	A
	R32G32B32_FLOAT	FLOAT	R	G	B	-
	R32G32B32_SINT	SINT	R	G	B	-
	R32G32B32_UINT	UINT	R	G	B	-
	R32G32B32_UNORM	FLOAT	R	G	B	-
	R32G32B32_SNORM	FLOAT	R	G	B	-
	R32G32B32_SSCALED	FLOAT	R	G	B	-
	R32G32B32_USCALED	FLOAT	R	G	B	-
HSW:B+	R32G32B32_SFIXED	FLOAT	R	G	B	-
	R16G16B16A16_UNORM	FLOAT	R	G	B	A



Project	Source Element	Converted Component				
	Surface Format Name	Format	0	1	2	3
	R16G16B16A16_SNORM	FLOAT	R	G	B	A
	R16G16B16A16_SINT	SINT	R	G	B	A
	R16G16B16A16_UINT	UINT	R	G	B	A
	R16G16B16A16_FLOAT	FLOAT	R	G	B	A
	R32G32_FLOAT	FLOAT	R	G	-	-
	R32G32_SINT	SINT	R	G	-	-
	R32G32_UINT	UINT	R	G	-	-
	R32G32_UNORM	FLOAT	R	G	-	-
	R32G32_SNORM	FLOAT	R	G	-	-
	R64_FLOAT	FLOAT	R	-	-	-
	R16G16B16A16_SSCALED	FLOAT	R	G	B	A
	R16G16B16A16_USCALED	FLOAT	R	G	B	A
	R32G32_SSCALED	FLOAT	R	G	-	-
	R32G32_USCALED	FLOAT	R	G	-	-
HSW:B+	R32G32_SFIXED	FLOAT	R	G	-	-
	B8G8R8A8_UNORM	FLOAT	B	G	R	A
	R10G10B10A2_UNORM	FLOAT	R	G	B	A
	R10G10B10A2_UINT	UINT	R	G	B	A
	R10G10B10_SNORM_A2_UNORM	FLOAT	R	G	B	A
	R8G8B8A8_UNORM	FLOAT	R	G	B	A
	R8G8B8A8_SNORM	FLOAT	R	G	B	A
	R8G8B8A8_SINT	SINT	R	G	B	A
	R8G8B8A8_UINT	UINT	R	G	B	A
	R16G16_UNORM	FLOAT	R	G	-	-
	R16G16_SNORM	FLOAT	R	G	-	-
	R16G16_SINT	SINT	R	G	-	-
	R16G16_UINT	UINT	R	G	-	-
	R16G16_FLOAT	FLOAT	R	G	-	-
HSW:B+	B10G10R10A2_UNORM	FLOAT	R	G	B	A
	R11G11B10_FLOAT	FLOAT	R	G	B	-
	R32_SINT	SINT	R	-	-	-
	R32_UINT	UINT	R	-	-	-
	R32_FLOAT	FLOAT	R	-	-	-
	R32_UNORM	FLOAT	R	-	-	-
	R32_SNORM	FLOAT	R	-	-	-
	R10G10B10X2_USCALED	FLOAT	R	G	B	-
	R8G8B8A8_SSCALED	FLOAT	R	G	B	A
	R8G8B8A8_USCALED	FLOAT	R	G	B	A



Project	Source Element	Converted Component				
	Surface Format Name	Format	0	1	2	3
	R16G16_SScaled	FLOAT	R	G	-	-
	R16G16_UScaled	FLOAT	R	G	-	-
	R32_SScaled	FLOAT	R	-	-	-
	R32_UScaled	FLOAT	R	-	-	-
	R8G8_UNORM	FLOAT	R	G	-	-
	R8G8_SNORM	FLOAT	R	G	-	-
	R8G8_SINT	SINT	R	G	-	-
	R8G8_UINT	UINT	R	G	-	-
	R16_UNORM	FLOAT	R	-	-	-
	R16_SNORM	FLOAT	R	-	-	-
	R16_SINT	SINT	R	-	-	-
	R16_UINT	UINT	R	-	-	-
	R16_FLOAT	FLOAT	R	-	-	-
	R8G8_SScaled	FLOAT	R	G	-	-
	R8G8_UScaled	FLOAT	R	G	-	-
	R16_SScaled	FLOAT	R	-	-	-
	R16_UScaled	FLOAT	R	-	-	-
	R8_UNORM	FLOAT	R	-	-	-
	R8_SNORM	FLOAT	R	-	-	-
	R8_SINT	SINT	R	-	-	-
	R8_UINT	UINT	R	-	-	-
	R8_SScaled	FLOAT	R	-	-	-
	R8_UScaled	FLOAT	R	-	-	-
	R8G8B8_UNORM	FLOAT	R	G	B	-
	R8G8B8_SNORM	FLOAT	R	G	B	-
	R8G8B8_SScaled	FLOAT	R	G	B	-
	R8G8B8_UScaled	FLOAT	R	G	B	-
HSW:B+	R8G8B8_SINT	SINT	R	G	B	-
HSW:B+	R8G8B8_UINT	UINT	R	G	B	-
	R64G64B64A64_FLOAT	FLOAT	R	G	B	A
	R64G64B64_FLOAT	FLOAT	R	G	B	A
	R16G16B16_FLOAT	FLOAT	R	G	B	-
	R16G16B16_UNORM	FLOAT	R	G	B	-
	R16G16B16_SNORM	FLOAT	R	G	B	-
	R16G16B16_SScaled	FLOAT	R	G	B	-
	R16G16B16_UScaled	FLOAT	R	G	B	-
HSW:B+	R16G16B16_UINT	UINT	R	G	B	-
HSW:B+	R16G16B16_SINT	SINT	R	G	B	-



Project	Source Element	Converted Component				
	Surface Format Name	Format	0	1	2	3
HSW:B+	R32_SF1XED	FLOAT	R	-	-	-
HSW:B+	R10G10B10A2_SNORM	FLOAT	R	G	B	A
HSW:B+	R10G10B10A2_USCALED	FLOAT	R	G	B	A
HSW:B+	R10G10B10A2_SSCALED	FLOAT	R	G	B	A
HSW:B+	R10G10B10A2_SINT	SINT	R	G	B	A
HSW:B+	B10G10R10A2_SNORM	FLOAT	R	G	B	A
HSW:B+	B10G10R10A2_USCALED	FLOAT	R	G	B	A
HSW:B+	B10G10R10A2_SSCALED	FLOAT	R	G	B	A
HSW:B+	B10G10R10A2_UINT	UINT	R	G	B	A
HSW:B+	B10G10R10A2_SINT	SINT	R	G	B	A

DestinationFormatSelection

The **Component Select 0..3** bits are then used to select, on a per-component basis, which destination components will be written and with which value. The supported selections are the converted source component, VertexID, InstanceID, PrimitiveID, the constants 0 or 1.0f, or nothing (VFCOMP_NO_STORE). If a converted component is listed as '-' (not available) in [Source Element Formats supported in VF Unit](#). It must not be selected (via VFCOMP_STORE_SRC), or an UNPREDICTABLE value will be stored in the destination component.

The selection process sequences from component 0 to 3. Once a **Component Select** of VFCOMP_NO_STORE is encountered, all higher-numbered **Component Select** settings must also be programmed as VFCOMP_NO_STORE. It is therefore not permitted to have 'holes' in the destination VE.

PrimitiveInfoGeneration

A PrimitiveID value and PrimStart boolean need to be associated with the vertex.

If the vertex is either the first vertex of an instance or the first vertex following a 'cut index', the vertex is marked with PrimStart.

PrimitiveID gets incremented such that subsequent per-object processing (i.e., in the GS or SF/WM) sees an incrementing value associated with each sequential object within an instance. The PrimitiveID associated with the provoking, non-adjacent vertex of an object is applied to the object.

The following pseudocode describe the logic used in the VertexLoop to compute the PrimitiveID value associated with the vertex. Recall that PrimitiveID is reset to 0 at the start of each InstanceLoop.

```

if ( PIDCounterS < S[primType] )
    PIDCounterS ++
else
    if ( PIDCounterR < R[primType] )
        PIDCounterR ++
    else
        PrimitiveID ++
        PIDCounterR = 0
endif

```



endif

Two counters are employed to control the incrementing of PrimitiveID. The counters are compared against two corresponding parameters associated with the primitive topology type.

The PIDCounterS is used to 'skip over' some number (possibly zero) initial vertices of the primitive topology. This counter gets reset to 0 after each primitive is terminated.

Then the PIDCounterR is used to periodically increment the PrimitiveID, where the incrementing interval (vertex count) is topology-specific.

The following table lists the S[] and R[] values associated with each primitive topology type.

PrimTopologyType	S, R	PrimitiveID Outputs
POINTLIST POINTLIST_BF	1, 0	0,1,2,3, ...
LINELIST LINELIST_ADJ	1, 1 1, 3	0,0,1,1,2,2,3,3, ... 0,0,0,0,1,1,1,1,2,2,2,2,3,3,3,3, ...
LINESTRIP LINESTRIP_BF LINESTRIP_CONT	2, 0	0,0,1,2,3, ...
LINESTRIP_ADJ	3, 0	0,0,1,2,3, ...
TRILIST RECTLIST	1, 2	0,0,0,1,1,1,2,2,2,3,3,3, ...
TRILIST_ADJ	1, 5	0,0,0,0,0,0,1,1,1,1,1,1,2,2,2,2,2, ...
TRISTRIP TRISTRIP_REV	3, 0	0,0,0,1,2,3, ...
TRISTRIP_ADJ	5, 1	0,0,0,0,0,0,1,1,2,2,3,3, ...
TRIFAN TRIFAN_NOSTIPPLE POLYGON	3, 0	0,0,0,1,2,3, ...
QUADLIST	1, 3	0,0,0,0,1,1,1,1,2,2,2,2,3,3,3,3, ... Note: The QUADLIST topology is converted to POLYGON topology at the beginning of the 3D pipeline.
QUADSTRIP	3, 1	0,0,0,0,1,1,2,2,3,3, ... Note: The QUADSTRIP topology is converted to POLYGON topology at the beginning of the 3D pipeline.



Project:	
PATCHLIST_n	
with S, R of 1, n-1	
PATCHLIST_1: 0,1,2,3, ...	
PATCHLIST_2: 0,0,1,1,2,2,3,3, ...	

URBWrite

The selected destination components are written into the destination VUE starting at **Destination Offset Select**. See the description of 3DPRIMITIVE for restrictions on this field.

OutputBufferedVertex

In order to accommodate 'cut' processing, the VF unit buffers one output vertex. The generation of a new vertex or the termination of a primitive causes the buffered vertex to be output to the pipeline.

Dangling Vertex Removal

The last functional stage of processing of the 3DPRIMITIVE command is the removal of "dangling" vertices. This stage includes the discarding of primitive topologies without enough vertices for a single object (e.g., a TRISTRIP with only two vertices), as well as the discarding of trailing vertices that do not form a complete primitive (e.g., the last two vertices of a 5-vertex TRILIST).

This function is best described as a filter operating on the vertex stream emitted from the processing of the 3DPRIMITIVE. The filter inputs the PrimType, PrimStart, and PrimEnd values associated with the generated vertices. The filter only outputs primitive topologies without dangling vertices. This requires the filter to (a) be able to buffer some number of vertices, and (b) be able to remove dangling vertices from the pipeline and dereference the associated VUE handles.

Statistics Gathering

3DSTATE_VF_STATISTICS

Vertices Generated

VF will increment the IA_VERTICES_COUNT Register (see Memory Interface Registers in Volume Ia, GPU) for each vertex it fetches, even if that vertex comes from a cache rather than directly from a vertex buffer in memory. Any "dangling" vertices (fetched vertices that are part of an incomplete object) will not be included.



Objects Generated

VF will increment the IA_PRIMITIVES_COUNT Register (see Memory Interface Registers in vol1a System Overview) for each object (point, line, triangle, or quadrilateral) that it forwards down the pipeline.

Project	Note
	For LINELOOP, the last (closing) line object is not counted.



Vertex Shader (VS) Stage

VS Stage Overview

The VS stage of the 3D Pipeline is used to perform processing ("shading") of vertices after being assembled and written to the URB by the VF function. The primary function of the VS stage is to pass vertices that miss in the Vertex Cache to VS threads, and then pass the VS thread-generated vertices down the pipeline. Vertices that hit in the Vertex Cache are passed down the pipeline unmodified.

When the VS stage is disabled, vertices flow through the unit unmodified (i.e., as written by the VF unit).

Refer to the *Common 3D FF Unit Functions* subsection in the *3D Overview* chapter for a general description of a 3D pipeline stage, as much of the VS stage operation and control falls under these "common" functions; i.e., most stage state variables and VS thread payload parameters are described in *3D Overview*, and although they are listed here for completeness, that chapter provides the detailed description of the associated functions.

Refer to this chapter for an overall description of the VS stage, and any exceptions the VS stage exhibits with respect to common FF unit functions.

State

URB_FENCE

Refer to *3D Overview* for a description of how the VS stage processes this command.

3DSTATE_VS

3DSTATE_CONSTANT_VS

3DSTATE_PUSH_CONSTANT_ALLOC_VS

3DSTATE_BINDING_TABLE_POINTERS_VS

3DSTATE_SAMPLER_STATE_POINTERS_VS

3DSTATE_URB_VS

Functions

The following pages describe the Vertex Shader Functions.

Vertex Shader Cache (VS\$)

Note: The VS\$ should not be confused with input data caches used by the VF stage when fetching data from index or vertex buffers in memory.

The 3D Pipeline employs a Vertex Shader Cache (VS\$) that is shared between the VF and VS stages. (See *Vertex Fetch* chapter for additional information). The vertex index generated by the VF stage is used as the cache tag. The cached data contains the URB handle of a VUE, which in turn typically contains the



vertex data output from a previously-executed VS shader, though if the VS function is disabled the VUE will contain the input vertex data generated by the VF stage.

When the VF stage processes a vertex, it will first perform a lookup in the VS\$. If the vertex hits in the VS\$, the VS stage will return the hit VUE handle to the VF stage, and the VF stage will subsequently pass the returned VUE handle back down the FF pipeline to VS. If the vertex misses in the VS\$ (or always, if the VS\$ is disabled), the VS stage will allocate a VUE handle for the miss vertex and return this to the VF stage. The VF stage will then proceed to fetch/generate the input vertex data, store the results into the VUE, and then pass the VUE down to the VS stage. If the VS function is enabled, the VUE handle/data will be used as input to a VS shader thread, and that thread will overwrite the VUE with the shader results.

The VS\$ may be explicitly DISABLED via the Vertex Cache Disable bit in 3DSTATE_VS. Even when explicitly ENABLED, the VS stage will (by default) implicitly disable the VS\$ whenever it detects one of the following conditions:

Project	Condition
	Sequential indices are used in the 3DPRIMITIVE command (though this is effectively a don't care as there would not be any VS\$ hits).

The implicit disable persists as long as one of these conditions persist, afterwhich the VS\$ is invalidated.

The VS\$ is implicitly invalidated between 3DPRIMITIVE commands and between instances within a 3DPRIMITIVE command – therefore use of InstanceID in a Vertex Element is not a condition under which the cache is implicitly disabled.

The following table summarizes the modes of operation of the VS\$.

VS\$	VS Function Enable	Mode of Operation
DISABLED (implicitly or explicitly)	DISABLED	The VS\$ is not used. VF stage assembles all vertices and writes them into the VUE supplied by the VS stage. VS stage subsequently passes references to these VUEs down the pipeline without spawning any VS threads. Usage Model: This is an exceptional condition, only required for ([Pre-DevHSW]) when the VF-generated vertices contain PrimitiveID. Otherwise the VS\$ should be enabled.
	ENABLED	The VS\$ is not used. VF stage assembles all vertices and writes them into the VUE supplied by the VS stage. VS stage subsequently spawns VS threads to process all vertices, overwriting the input data with the results. The VS stage pass references to these VUEs down the pipeline. Usage Model: This mode is only used when the VS function is required, but either (a) the VS kernel produces a side effect (e.g., writes to a memory buffer) which in turn requires every vertex to be processed by a VS thread, or (b) ([Pre-DevHSW]) the input vertex contains PrimitiveID.
ENABLED	DISABLED	The VS\$ is used to provide reuse of VF-generated vertices. The VF stage checks the cache and only processes (assembles/writes) vertices that miss in the VS\$. In either case, the VS stage passes references to vertices (that hit or miss) down the pipeline without spawning any VS threads.



VS\$	VS Function Enable	Mode of Operation
		Usage Model: Normal operation when the VS function is not required (e.g., SW has detected a VS shader that simply copies outputs to inputs).
	ENABLED	The VS\$ is used to provide reuse of VS-processed vertices. The VF stage checks the cache and only processes (assembles/writes) vertices that miss in the VS\$. The VS stage only processes (shades) the vertices that missed in the VS\$. The VS stage sends references to hit or missed vertices down the pipeline in the correct order. Usage Model: Normal operation when the VS function is required and use of the VS\$ is permissible.

SIMD4x2 VS Thread Request Generation

Project	Description
	This section describes SIMD4x2 thread request generation, which is the only mode available.

The following discussion assumes the VS Function is ENABLED.

When the Vertex Cache is disabled, the VS unit passes each pair of incoming vertices to a VS thread. Under certain circumstances (e.g., prior to a state change or pipeline flush) the VS unit spawns a VS thread to process a single vertex. Note that, in this case, the "unused" vertex slot is "disabled" via the Execution Mask provided by the VS unit to the GEN4 subsystem as part of the thread dispatch (See the EU ISA volume). The VS thread is itself unaware of the single-vertex case, and therefore a single VS kernel can be used to process one or two vertices. (The performance of single-vertex processing roughly equals the two-vertex case.)

When the Vertex Cache is enabled, the VF unit detects vertices that hit in the cache and marks these vertices so that they bypass VS thread processing and are output via a reference to the cached VUE. The VS unit keeps track of these cache-hit vertices as it proceeds to process cache-miss vertices. The VS unit guarantees that vertices exit the unit in the order they are received. This may require the VS unit to issue single-vertex VS threads to process a cache-miss vertex that has yet to be paired up with another cache-miss vertex (if this condition is preventing the VS unit from producing any output).

SIMD4x2 VS Thread Execution

Project	Description
	This section describes SIMD4x2 thread execution, which is the only mode available.

A VS kernel (with one exception mentioned below) assumes it is to operate on two vertices in parallel. Input data is either passed directly in the thread payload (including the input vertex data) or indirectly via pointers passed in the payload.

Refer to the *EU ISA* chapters for specifics on writing kernels that operate in SIMD4x2 fashion.



Refer to the 3D Pipeline Stage Overview (*3D Overview*) for information on FF-unit/thread interactions.

In the (unlikely) event that the VS kernel needs to determine whether it is processing one or two vertices, the kernel can compare the **URB Return Handle 0** and **URB Return Handle 1** fields of the thread payload. These fields differ if two vertices are being processed, and identical if one vertex is being processed. An example of when this test may be required is if the kernel outputs some vertex-dependent results into a memory buffer; without the test the single vertex case might incorrectly output two sets of results. Note that this is not the case for writing the URB destinations, as the Execution Mask prevents the write of an undefined output.

Vertex Output

VS threads must always write the destination URB handles passed in the payload. VS threads are not permitted to request additional destination handles. Refer to 3D Pipeline Stage Overview (*3D Overview*) for details on how destination vertices are written and any required contents/formats.

Thread Termination

VS threads must signal thread termination, in all likelihood on the last message output to the URB shared function. Refer to the *ISA* doc for details on End-Of-Thread indication.

Primitive Output

The VS unit will produce an output vertex reference for every input vertex reference received from the VF unit, in the order received. The VS unit simply copies the PrimitiveType, StartPrim, and EndPrim information associated with input vertices to the output vertices, and does not use this information in any way. Neither does the VS unit perform any readback of URB data.

Statistics Gathering

The VS stage tracks a single pipeline statistic, the number of times a vertex shader is executed. A vertex shader is executed for each vertex that is fetched on behalf of a 3DPRIMITIVE command, unless the shaded results for that vertex are already available in the vertex cache. If the **Statistics Enable** bit in VS_STATE is set, the VS_INVOCATION_COUNT Register (see Memory Interface Registers in Volume Ia, *GPU*) will be incremented for *each vertex* that is dispatched to a VS thread. This counter will often need to be incremented by 2 for each thread invoked since 2 vertices are dispatched to one VS thread in the general case.

Payloads

The following pages describe the Vertex Shader Payloads.

SIMD4x2 Payload

The following table describes the payload delivered to VS threads.



VS Thread Payload (SIMD4x2)

DWord	Bits	Description								
	30:0	Reserved								
R0.6	31:24	Reserved								
	23:0	<p>Thread ID. This field uniquely identifies this thread within the threads spawned by this FF unit, over some period of time.</p> <p>Format: Reserved for HW Implementation Use.</p>								
R0.5	31:10	<p>Scratch Space Offset: Specifies the extent of the scratch space allocated to the thread, specified as a 1KB-granular offset from the General State Base Address. See Scratch Space Base Offset description in VS_STATE.</p> <p>(See <i>3D Pipeline</i> for further description on scratch space allocation).</p> <p>Format = GeneralStateOffset[31:10]</p>								
	9	<table border="1"> <tr> <td>Project:</td> <td></td> </tr> <tr> <td colspan="2">Reserved</td> </tr> </table>	Project:		Reserved					
Project:										
Reserved										
	8:0	<p>FFTID: This ID is assigned by the FF unit and used to identify the thread within the set of outstanding threads spawned by the FF unit.</p> <p>Format: Reserved for HW Implementation Use.</p> <p>Format:</p> <table border="1"> <thead> <tr> <th>Project</th> <th>Format</th> </tr> </thead> <tbody> <tr> <td>HSW</td> <td>U8</td> </tr> </tbody> </table> <p>Range:</p> <table border="1"> <thead> <tr> <th>Project</th> <th>Range</th> </tr> </thead> <tbody> <tr> <td>HSW</td> <td>0-255</td> </tr> </tbody> </table>	Project	Format	HSW	U8	Project	Range	HSW	0-255
Project	Format									
HSW	U8									
Project	Range									
HSW	0-255									
	9:0									
R0.4	31:5	<p>Binding Table Pointer. Specifies the 32-byte aligned pointer to the Binding Table. It is specified as an offset from the Surface State Base Address.</p> <p>Format = SurfaceStateOffset[31:5]</p>								
	4:0	Reserved								
R0.3	31:5	<p>Sampler State Pointer. Specifies the location of the Sampler State Table to be used by this thread, specified as a 32-byte granular offset from the General State Base Address or the Dynamic State Base Address.</p> <p>Format = DynamicStateOffset[31:5]</p>								
	4	Reserved								



DWord	Bits	Description				
	3:0	<p>Per Thread Scratch Space: Specifies the amount of scratch space allowed to be used by this thread. The value specifies the power that two will be raised to (over determine the amount of scratch space).</p> <p>(See <i>3D Pipeline</i> for further description).</p> <p>Format = U4 power of two (in excess of 10)</p> <p>Range = [0,11] indicating [1K Bytes, 2M Bytes]</p>				
R0.2	31:0	Reserved: delivered as zeros (reserved for message header fields)				
R0.1	31:16	Reserved				
	15:0	<p>URB Return Handle 1: This is the 64B-aligned URB offset where the EU's upper channels (DWords 7:4) results are to be stored.</p> <p>If only one vertex is to be processed (shaded) by the thread, this field will effectively be ignored (no results are stored for these channels, as controlled by the thread's Channel Mask).</p> <p>(See <i>Generic FF Unit</i> for further description).</p> <p>Format:</p> <table border="1" data-bbox="354 982 1494 1066"> <thead> <tr> <th>Project</th> <th>Format</th> </tr> </thead> <tbody> <tr> <td>HSW</td> <td>U13 64B-aligned URB offset.</td> </tr> </tbody> </table>	Project	Format	HSW	U13 64B-aligned URB offset.
Project	Format					
HSW	U13 64B-aligned URB offset.					
R0.0	31:16	Reserved				
	15:0	<p>URB Return Handle 0: This is the 64B-aligned URB offset where the EU's lower channels (DWords 3:0) results are to be stored.</p> <p>(See <i>Generic FF Unit</i> for further description).</p> <p>Format:</p> <table border="1" data-bbox="354 1329 1494 1413"> <thead> <tr> <th>Project</th> <th>Format</th> </tr> </thead> <tbody> <tr> <td>HSW</td> <td>U13 64B-aligned URB offset.</td> </tr> </tbody> </table>	Project	Format	HSW	U13 64B-aligned URB offset.
Project	Format					
HSW	U13 64B-aligned URB offset.					
[Varies] optional	255:0	<p>Constant Data (optional):</p> <p>Some amount of constant data (possible none) can be extracted from the push constant buffer (PCB) and passed to the thread following the R0 Header. The amount of data provided is defined by the sum of the read lengths in the last 3DSTATE_CONSTANT_VS command (taking the buffer enables into account).</p> <p>The Constant Data arrives in a non-interleaved format.</p>				
Varies	255:0	<p>Vertex Data: Data from (possibly) one or (more typically) two Vertex URB Entries is passed to the thread in the thread payload. The Vertex URB Entry Read Offset and Vertex URB Entry Read Length state variables define the regions of the URB entries that are read from the URB and passed in the thread payload. These SVs can be used to provide a subset of the URB data as required by SW.</p>				



DWord	Bits	Description
		The vertex data is laid out in the thread header in an interleaved format. The lower DWords (0-3) of these GRF registers always contain data from a Vertex URB Entry. The upper DWords (4-7) may contain data from another Vertex URB Entry. This allows two vertices to be processed (shaded) in parallel SIMD8 fashion. The VS kernel is not aware of the validity of the upper vertex.



3D Pipeline – Hull Shader (HS) Stage

The Hull Shader (HS) stage of the pipeline is used to process patchlist (PATCHLIST_*n*) topologies in support of higher-order surface (HOS) tessellation. If the HS stage is enabled, each incoming patch object is processed by a possible series of HS threads. The combined output of these threads is a Patch URB Entry ("patch record") written to the URB. This patch record is used by subsequent stages (TE, DS) to complete the HOS tessellation operations.

For SW Tessellation mode, the HS thread can also write tessellated domain point topologies to memory. The domain point count and starting memory address of the domain points are passed via the Patch Header in the patch record.

The vertices associated with patchlist primitives are also referred to as "Input Control Points" (ICPs) to contrast them with any "Output Control Points" the HS threads may write to the patch record. (The definition and use of OCPs are outside the scope of this document).

The HS stage also performs statistics counting. Incomplete topologies do not reach the HS stage.

The HS, TE, and DS stages must be enabled and disabled together. When these stages are disabled, all topologies (including patchlist topologies) simply pass through to the GS stage. When these stages are enabled, only patchlist topologies should be issued to the pipeline, otherwise behavior is UNDEFINED.

State

This section contains the state registers for the Hull Shader.

3DSTATE_HS

3DSTATE_PUSH_CONSTANT_ALLOC_HS

3DSTATE_CONSTANT_HS

3DSTATE_CONSTANT(Body)

3DSTATE_BINDING_TABLE_POINTERS_HS

3DSTATE_SAMPLER_STATE_POINTERS_HS

3DSTATE_URB_HS

Functions

Patch Object Staging

The HS unit accepts patchlist topologies as a stream of incoming vertices. Depending on the number of vertices per patch object (as specified by the PATCHLIST_*n* topology), the HS thread assembles each complete patch object and passes it (its vertices, PrimitiveID, etc.) to HS thread(s) as described below.

HS Thread Execution

Input to HS threads is comprised of:



- Input Control Points (incoming patch vertices), pushed into the payload and/or passed indirectly via URB handles.
- Push Constants (common to all threads)
- Patch Data handle
- Resources available via binding table entries (accessed through shared functions)
- Miscellaneous payload fields (Instance Number, etc.)

Typically the only output of the HS threads is the Patch URB Entry (patch record). All thread instances for an input patch are passed the same patch record handle. As the (possibly concurrent) threads can both read and write the patch record, it is up to the kernels to ensure deterministic results. One approach would be to use the thread's Instance Number as an index for URB write destinations.

Dispatch Mask

HS threads are dispatched with the dispatch mask set to 0xFFFF. It is the responsibility of the kernel to modify the execution mask as required (e.g., if operating in SIMD4x2 mode but only the lower half is active, as would happen in one thread if the threads were computing an odd number of OCPs via SIMD4x2 operation).

Patch URB Entry (Patch Record) Output

For each patch, the HS thread(s) generate a single patch record, starting with a fixed 32B Patch Header. When the final thread instance terminates, the patch record handle is passed down the pipeline to the Tessellation Engine (TE).

Patch Header DW0-7

The first 8 DWords of the patch record is defined as a "Patch Header". The Patch Header is written by an HS thread and read by the TE stage. It normally contains up to six **Tessellation Factors** (TFs) that determine how finely the TE stage needs to tessellate a domain (if at all).

Project:	HSW
<p>In SW Tessellation mode, the header contains Domain Point Count and Domain Point Buffer Starting Address fields which identify the domain points generated by an HS thread.</p> <p>The following tables show the fixed layouts of the Patch Header DW0-7, depending on DomainType and SW Tessellation Mode.</p> <p>HW Bug: The Tessellation stage will incorrectly add domain points along patch edges under the following conditions, which may result in conformance failures and/or cracking artifacts:</p> <ul style="list-style-type: none">• QUAD domain	

Project:	HSW
<ul style="list-style-type: none"> • INTEGER partitioning • All three TessFactors in a given U or V direction (e.g., V direction: UEQ0, InsideV, UEQ1) are all exactly 1.0 • All three TessFactors in the other direction are > 1.0 and all round up to the same integer value (e.g, U direction: VEQ0 = 3.1, InsideU = 3.7, VEQ1 = 3.4) <p>The suggested workaround (to be implemented as part of the postamble to the HS shader in the HS kernel) is:</p> <pre> if ((TF[UEQ0] > 1.0) (TF[VEQ0] > 1.0) (TF[UEQ1] > 1.0) (TF[VEQ1] > 1.0) (TF[INSIDE_U] > 1.0) (TF[INSIDE_V] > 1.0)) { TF[INSIDE_U] = (TF[INSIDE_U] == 1.0) ? 2.0 : TF[INSIDE_U]; TF[INSIDE_V] = (TF[INSIDE_V] == 1.0) ? 2.0 : TF[INSIDE_V]; } </pre>	

Patch Header (QUAD Domain)

DWord	Bits	Description
7	31:0	UEQ0 Tessellation Factor Format: FLOAT32
6	31:0	VEQ0 Tessellation Factor Format: FLOAT32
5	31:0	UEQ1 Tessellation Factor Format: FLOAT32
4	31:0	VEQ1 Tessellation Factor Format: FLOAT32
3	31:0	Inside U Tessellation Factor Format: FLOAT32
2	31:0	Inside V Tessellation Factor



DWord	Bits	Description	
		Format: FLOAT32	
1	31:0	Reserved : MBZ	
0	31:1	Reserved : MBZ	
	0	Project	Descripti on
		HSW	Reserved: MBZ

Patch Header (TRI Domain)

DWord	Bits	Description	
7	31:0	UEQ0 Tessellation Factor Format: FLOAT32	
6	31:0	VEQ0 Tessellation Factor Format: FLOAT32	
5	31:0	WEQ0 Tessellation Factor Format: FLOAT32	
4	31:0	Inside Tessellation Factor Format: FLOAT32	
3-1	31:0	Reserved : MBZ	
0	31:1	Reserved : MBZ	
	0	Project	Descripti on
		HSW	Reserved: MBZ



Patch Header (ISOLINE Domain)

DWord	Bits	Description
7	31:0	Line Detail Tessellation Factor Format: FLOAT32
6	31:0	Line Density Tessellation Factor Format: FLOAT32
5-0	31:0	Reserved : MBZ

Project:		HSW
Patch Header (SW Tessellation Mode)		
DWord	Bits	Description
7	31:0	Domain Point Count Specifies the number of DOMAIN_POINT structures in the domain point list in memory. If 0, there are no domain points defined, the patch will considered "culled", and the TE stage will discard the patch. Otherwise the TS stage will send this number of domain points down the pipeline. Format: U32
6	31:6	Domain Point Buffer Starting Address (DPBSA) This field specifies the starting memory offset from SW Tessellation Base Address (set by the SWTESS_BASE_ADDRESS command) at which the HS thread has written a list of DOMAIN_POINT structures. This field is ignored if Domain Point Count is 0. Format: 64B-aligned offset from SW Tessellation Base Address
	5:0	Reserved: MBZ
5-0	31:0	Reserved: MBZ

DOMAIN_POINT Structure

In SW Tessellation Mode (i.e., when the TE State is SW_TESS), the TE stage reads a sequence of DOMAIN_POINT structures from memory, starting at the Domain Point Buffer Starting Address field of the patch header. (The DPBSA is treated as an offset from the SW Tessellation Base Address as set by the SWTESS_BASE_ADDRESS command.)



DOMAIN_POINT Memory Structure (SW Tessellation)

DWord	Bits	Description
0	31	PrimStart Set on the first domain point of the topology (e.g., first vertex in a TRISTRIP).
	30	PrimEnd Set on the last domain point of the topology (e.g., last vertex in a TRISTRIP). Programming note: Software must ensure that incomplete primitives are not output, or behavior is UNDEFINED.
	29	PatchEnd Set on the last domain point for the <u>patch</u> . By definition, PrimEnd must also be set. Programming Note: Software must ensure that the Domain Point Count coincides with the domain point marked with PatchEnd.
	28:24	PrimType This is the primitive topology type. Format: See 3DPRIMITIVE for encodings Valid values: POINTLIST, LINESSTRIP, LINELIST, TRISTRIP, TRISTRIP_REV, TRILIST, TRIFAN.
	23:19	Reserved
	18:17	DS Tag [16:15] This field provides bits [16:15] of the DS Tag value for this domain point. See DS Tag [14:0] . Format: U2
	16:0	U Coordinate Format: U1.16
1	31:17	DS Tag [14:0] This field provides bits [14:0] of the DS Tag value for this domain point. In order to utilize the DS cache, the 17-bit DS Tag must be unique for the associated U,V coordinate. If software cannot guarantee this, the DS cache must be disabled when in SW Tessellation mode. Format: U15
	16:0	V Coordinate Format: U1.16



Statistics Gathering

HS Invocations

The HS unit controls the HS_INVOCATIONS counter, which counts the number of patches processed by the HS stage.

ICP Dereferencing

If ICPs are only pushed in HS payloads (i.e., the **Include Vertex Handles** state bit is clear), the ICP handles are automatically released after the last instance for the patch is dispatched.

If **Include Vertex Handles** is set, the HS thread(s) will be reading ICP data in from the URB; it is the responsibility of the HS thread instances to explicitly dereference *all* the ICP handles via use of the **Complete** bit in URB_READ_XXX commands.

- If only one instance is used, that instance can dereference the ICP handles as soon as they are no longer needed, by setting **Complete** in the last URB_READ from that handle. Otherwise all (or the remaining) ICP handles need to be explicitly dereferenced via (possibly null-response-length) URB_READ commands prior to thread EOT.
- If more than one instance is spawned, the last-terminating instance is responsible for dereferencing all the ICP handles before it terminates. Instances can detect that they are the last-terminating thread via use of the semaphore allocated to the patch (via the **Semaphore Handle** and **Semaphore Index** payload fields). An URB_ATOMIC_INC operation (URB_ATOMIC command) can be performed on this semaphore by each instance prior to terminating. Only the last-terminating thread will observe the value (InstanceCount – 1) as a return value. After dereferencing all the ICPs, the last-terminating thread must also reset the semaphore to 0 via the URB_ATOMIC_MOV operation.



Payloads

SINGLE_PATCH Payload

The following table shows the layout of the payload delivered to HS threads. Refer to 3D Pipeline Stage Overview (*3D Pipeline*) for details on those fields that are common amongst the various pipeline stages.

Patch object vertex (ICP) data can be passed by value (data pushed in the payload) and/or by reference (URB handle pushed in the payload).

SINGLE_PATCH HS Thread Payload

GRF DWord	Bits	Description	Project	Security							
R0.7	31										
	30:0	Reserved.									
R0.6	31	<p>Dereference Thread</p> <p>This bit is defined to send back the Handle ID back to HS to dereference the input handles for this thread.</p>									
	30:24	Reserved.									
	23:0	<p>Thread ID. This field uniquely identifies this thread within the threads spawned by this FF unit, over some period of time.</p> <p>Format: Reserved for HW Implementation Use.</p>									
R0.5	31:10	<p>Scratch Space Pointer. Specifies the location of the scratch space allocated to this thread, specified as a 1KB-aligned offset from the General State Base Address.</p> <p>Format = GeneralStateOffset[31:10]</p>									
	9:0	Reserved.									
	8:0	<p>FFTID. This ID is assigned by the fixed function unit and is relative identifier for the thread. It is used to free up resources used by the thread upon thread completion.</p> <p>Format:</p> <table border="1" data-bbox="321 1564 1055 1654"> <thead> <tr> <th>Project</th> <th>Format</th> </tr> </thead> <tbody> <tr> <td>HSW</td> <td>U8</td> </tr> </tbody> </table> <p>Range:</p> <table border="1" data-bbox="321 1711 1055 1801"> <thead> <tr> <th>Project</th> <th>Range</th> </tr> </thead> <tbody> <tr> <td>HSW</td> <td>0-255</td> </tr> </tbody> </table>	Project	Format	HSW	U8	Project	Range	HSW	0-255	
Project	Format										
HSW	U8										
Project	Range										
HSW	0-255										



GRF DWord	Bits	Description	Project	Security
R0.4	31:5	<p>Binding Table Pointer: Specifies the 32-byte aligned pointer to the Binding Table. It is specified as an offset from the Surface State Base Address.</p> <p>Format = SurfaceStateOffset[31:5]</p>		
	4:0	Reserved.		
R0.3	31:5	<p>Sampler State Pointer. Specifies the location of the Sampler State Table to be used by this thread, specified as a 32-byte granular offset from the General State Base Address or Dynamic State Base Address.</p> <p>Format = DynamicStateOffset[31:5]</p>		
	4	Reserved.		
	3:0	<p>Per Thread Scratch Space. Specifies the amount of scratch space allowed to be used by this thread. The value specifies the power that two will be raised to (over determine the amount of scratch space).</p> <p>Programming Notes:</p> <p>This amount is available to the kernel for information only. It is passed verbatim (if not altered by the kernel) to the Data Port in any scratch space access messages, but the Data Port ignores it.</p> <p>Format = U4 power of two (in excess of 10)</p> <p>Range = [0,11] indicating [1K Bytes, 2M Bytes]</p>		
R0.2	31:24	<p>Semaphore Index. This is a Dword index to be used in URB_ATOMIC commands if the thread is using data pulled from input handles. This information is only required for pull-model vertex inputs and InstanceCount>1.</p> <p>Format = U8</p>	HSW	
	23:17	<p>Instance Number. A patch-relative instance number between 0 and InstanceCount-1.</p> <p>Format = U7</p>	HSW	
	16:13	<p>Barrier Index. This index is to be used in any BarrierMsgs sent by this thread to the Gateway.</p> <p>Format = U4</p>	HSW	
	12:0	<p>Semaphore Handle: This is the URB handle pointing to the first HS semaphore DWord in the URB. Software is responsible for statically allocating the semaphore Dwords in the URB. Refer to Semaphore Handle field in 3DSTATE_HS for size of semaphore allocation.</p> <p>Format: U12 64B-aligned URB Offset</p>	HSW	



GRF DWord	Bits	Description	Project	Security			
R0.1	31:0	Primitive ID. This field contains the Primitive ID associated with the patch. Format: U32					
R0.0	31:16	Reserved.					
	15:0	Patch Data Record URB Return Handle. Format: <table border="1" style="margin-left: auto; margin-right: auto;"> <thead> <tr> <th>Project</th> <th>Format</th> </tr> </thead> <tbody> <tr> <td>HSW</td> <td>U13 64B-aligned URB offset.</td> </tr> </tbody> </table>	Project	Format	HSW	U13 64B-aligned URB offset.	
Project	Format						
HSW	U13 64B-aligned URB offset.						
R1 is only included for dispatches that have Include Vertex Handles enabled.							
R1.7	31:16	ICP 7 Handle ID					
	15:0	ICP 7 Handle Format: <table border="1" style="margin-left: auto; margin-right: auto;"> <thead> <tr> <th>Project</th> <th>Format</th> </tr> </thead> <tbody> <tr> <td>HSW</td> <td>U13 64B-aligned URB offset.</td> </tr> </tbody> </table>	Project	Format	HSW	U13 64B-aligned URB offset.	
Project	Format						
HSW	U13 64B-aligned URB offset.						
R1.6	31:16	ICP 6 Handle ID					
	15:0	ICP 6 Handle					
R1.5	31:16	ICP 5 Handle ID					
	15:0	ICP 5 Handle					
R1.4	31:16	ICP 4 Handle ID					
	15:0	ICP 4 Handle					
R1.3	31:16	ICP 3 Handle ID					
	15:0	ICP 3 Handle					
R1.2	31:16	ICP 2 Handle ID					
	15:0	ICP 2 Handle					
R1.1	31:16	ICP 1 Handle ID					
	15:0	ICP 1 Handle					
R1.0	31:16	ICP 0 Handle ID					
	15:0	ICP 0 Handle					
R2 is only included for dispatches that have Include Vertex Handles enabled and when ICP Count >7							
R2.7	31:16	ICP 15 Handle ID					
	15:0	ICP 15 Handle					
R2.6	31:16	ICP 14 Handle ID					
	15:0	ICP 14 Handle					
R2.5	31:16	ICP 13 Handle ID					



GRF DWord	Bits	Description	Project	Security
	15:0	ICP 13 Handle		
R2.4	31:16	ICP 12 Handle ID		
	15:0	ICP 12 Handle		
R2.3	31:16	ICP 11 Handle ID		
	15:0	ICP 11 Handle		
R2.2	31:16	ICP 10 Handle ID		
	15:0	ICP 10 Handle		
R2.1	31:16	ICP 9 Handle ID		
	15:0	ICP 9 Handle		
R2.0	31:16	ICP 8 Handle ID		
	15:0	ICP 8 Handle		
R3 is only included for dispatches that have Include Vertex Handles enabled and when ICP Count >15				
R3.7	31:16	ICP 23 Handle ID		
	15:0	ICP 23 Handle		
R3.6	31:16	ICP 22 Handle ID		
	15:0	ICP 22 Handle		
R3.5	31:16	ICP 21 Handle ID		
	15:0	ICP 21 Handle		
R3.4	31:16	ICP 20 Handle ID		
	15:0	ICP 20 Handle		
R3.3	31:16	ICP 19 Handle ID		
	15:0	ICP 19 Handle		
R3.2	31:16	ICP 18 Handle ID		
	15:0	ICP 18 Handle		
R3.1	31:16	ICP 17 Handle ID		
	15:0	ICP 17 Handle		
R3.0	31:16	ICP 16 Handle ID		
	15:0	ICP 16 Handle		
R4 is only included for dispatches that have Include Vertex Handles enabled and when ICP Count >23				
R4.7	31:16	ICP 31 Handle ID		
	15:0	ICP 31 Handle		
R4.6	31:16	ICP 30 Handle ID		
	15:0	ICP 30 Handle		
R4.5	31:16	ICP 29 Handle ID		
	15:0	ICP 29 Handle		
R4.4	31:16	ICP 28 Handle ID		
	15:0	ICP 28 Handle		



GRF DWord	Bits	Description	Project	Security
R4.3	31:16	ICP 27 Handle ID		
	15:0	ICP 27 Handle		
R4.2	31:16	ICP 26 Handle ID		
	15:0	ICP 26 Handle		
R4.1	31:16	ICP 25 Handle ID		
	15:0	ICP 25 Handle		
R4.0	31:16	ICP 24 Handle ID		
	15:0	ICP 24 Handle		
[Varies] optional	255:0	<p>Constant Data (optional):</p> <p>Some amount of constant data (possible none) can be extracted from the push constant buffer (PCB) and passed to the thread following the R0 Header. The amount of data provided is defined by the sum of the read lengths in the last 3DSTATE_CONSTANT_HS command (taking the buffer enables into account).</p>		
[Varies] optional	255:0	<p>ICP Vertex Data (optional):</p> <p>There can be up to 32 vertices supplied, each with a size defined by the Vertex URB Entry Read Length state.</p> <p>Vertex 0 DWord 0 is located at Rn.0, Vertex 0 DWord 1 is located at Rn.1, etc. Vertex 1 DWord 0 immediately follows the last DWord of Vertex 0, and so on.</p>		



HW Tessellation

When enabled, the Tessellation Engine (TE) stage performs fixed-function domain tessellation (decomposition into smaller objects) of incoming patches, as referenced by an HS-generated input PDR handle and as controlled by TE state and Tessellation Factors (TFs) read from the Patch URB Entry (patch record). The TE stage is entirely fixed-function and does not spawn threads.

Project	Description
	The TE stage can also operate in SW Tessellation mode, where it simply reads "pre-tessellated" domain point topologies from memory and passes them down the pipeline.

The fixed-function tessellation algorithm is considered an implementation detail and is therefore beyond the scope of this document. That detail includes both the order of output topologies as well as the order of vertices (domain points) within the output topologies. Only a high-level overview is provided to describe how the (few) state variables can be used to control aspects of tessellation behavior. The implementation will generate deterministic results (given the same exact inputs it will produce exactly the same outputs).

Several domain types (QUAD, TRI, and ISOLINE) are supported. Depending on the domain type, the TE stage outputs the required point/line/triangle topologies including a domain point per vertex. These topologies will be output to the DS stage, where the domain points will be converted to 3D object vertices, resulting in 3D objects as typically input to the 3D pipeline when HOS tessellation is not used.

The HS, TE, and DS stages must be enabled and disabled together. When these stages are disabled, all topologies (including patchlist topologies) simply pass through to the GS stage. When these stages are enabled, only patchlist topologies should be issued to the pipeline, else behavior is UNDEFINED. The MI_TOPOLOGY_FILTER command can be used to ensure this happens, i.e., it can be used to have the Command Stream ignore 3DPRIMITIVE commands that do not match a specific topology type.

State

This section contains the state registers for the Tessellation Engine.

3DSTATE_TE



Functions

Patch Culling

Normally, if any "outside" TF is ≤ 0.0 or NaN, the entire patch is culled at the TE stage.

Inside TFs are not used to cull patches.

Project	Description
HSW	In SW Tessellation mode, a Domain Point Count of 0 indicates that a patch is to be culled.

Tessellation Factor Limits

After the Patch Culling test is performed, the TessFactors undergo a `min()` clamp to either the **MaxTessFactorOdd** (for FRACTIONAL_ODD partitioning) or **MaxTessFactorNotOdd** (for FRACTIONAL_EVEN or INTEGER partitioning). Exception: If the ISOLINE domain is specified, the LineDensity TessFactor will be clamped to the **MaxFactorNotOdd** value even if FRACTIONAL_ODD partitioning is specified).

Usage Note: These max TessFactor values shall be programmed to values required by the APIs (refer to the 3DSTATE_TE definition).

Partitioning

The Partitioning state controls how the TFs are used to divide their corresponding edges.

- **INTEGER:** The edge is divided into an integral number of equal segments (given some fixed-point tolerance).
After clamping, the TF is rounded up to an integer value. The edge is divided into that many equal segments.
- **EVEN_FRACTIONAL:** The edge is divided into an *even* number of possibly-unequal segments. The total number of segments is determined by rounding up the post-clamped TF to an even number.
More specifically, the edge is divided exactly in half. Like the endpoints of the edge, the midpoint of the edge is by definition a tessellation point. Each half contains some number of equal segments and possibly one smaller segment. The size of the smaller segment is determined by the position of the TF value within the range defined by the TF rounded down and up to even numbers. The closer the TF is to the smaller value, the smaller the segment size is. When the TF reaches the smaller even value, the smaller segment disappears. The closer the TF gets to the larger even value, the closer the smaller segment size approaches the size of the other segments. When the TF reaches the larger even value, all segments are equal. The position of the smaller segment along the half edge varies as a function of the TF value.
- **ODD_FRACTIONAL:** The edge is divided into an *odd* number of possibly-unequal segments. The tessellation scheme is very similar to EVEN_FRACTIONAL partitioning, except that the edge midpoint is not included as a tessellation point. This, and the fact that the tessellation points are



mirrored about the edge midpoint, causes an "odd" segment (which may or may not be the "smaller" segment) to straddle the edge midpoint, therefore resulting in the number of segments for the edge always being odd.

Domain Types and Output Topologies

The major (if only) task of the TE stage is to tessellate a 2D (u,v) domain region, as selected by the Domain state, into some number of 2D object topologies. (If the patch is culled, that number may be zero). The options for Domain state are:

- QUAD: A square 2D region within a u,v Cartesian (rectangular) space. The region extends from the origin to $u=1$ and $v=1$. Within the region, tessellation domain locations are determined. The possible output topologies include points, clockwise triangles, and counter-clockwise triangles.
- TRI: A triangular 2D region with u,v,w barycentric (areal) coordinates. The three edges correspond to $u=0$, $v=0$, and $w=0$ boundaries. In barycentric coordinates, $w = 1 - u - v$, therefore points within the region are fully defined as 2D (u,v) coordinates. Within the region, tessellation domain locations are determined. The possible output topologies include points, clockwise triangles, and counter-clockwise triangles.
- ISOLINE: A series of points within a QUAD domain, where the points lie on lines parallel to the u axis and extending from [0,1) in the v direction. Either the segmented lines (linestrips) or individual point topologies can be output.

QUAD Domain Tessellation

The four *outside* TFs (TF.UEQ0, TF.VEQ0, TF.UEQ1, TF.VEQ1) are used to specify the level of tessellation along the four corresponding edges of the 2D quad domain. The two *inside* TFs (TF.InsideU, TF.InsideV) are used to determine the level of tessellation within a 2D *interior* region. Typically the interior region appears as a *regularly-tessellated 2D grid*, however under certain conditions the interior region may collapse in which case only the outside TFs are relevant.

In general, a transition region exists between each edge of the interior region and the corresponding outside edge. The topologies generated for these regions effectively *stitch together* locations along the outside and inside edges, as each of these edges can contain a different number of tessellated segments. In the case where all TFs in a given direction (e.g., TF.VEQ0, TF.InsideU, and TF.VEQ1) are the same value, it appears as if the regularly-tessellated interior region extends all the way to the outside edges. If this condition simultaneously exists for both u and v directions, the entire domain will appear to be tessellated into a regular grid, with no noticeable transition regions.



QUAD Domain

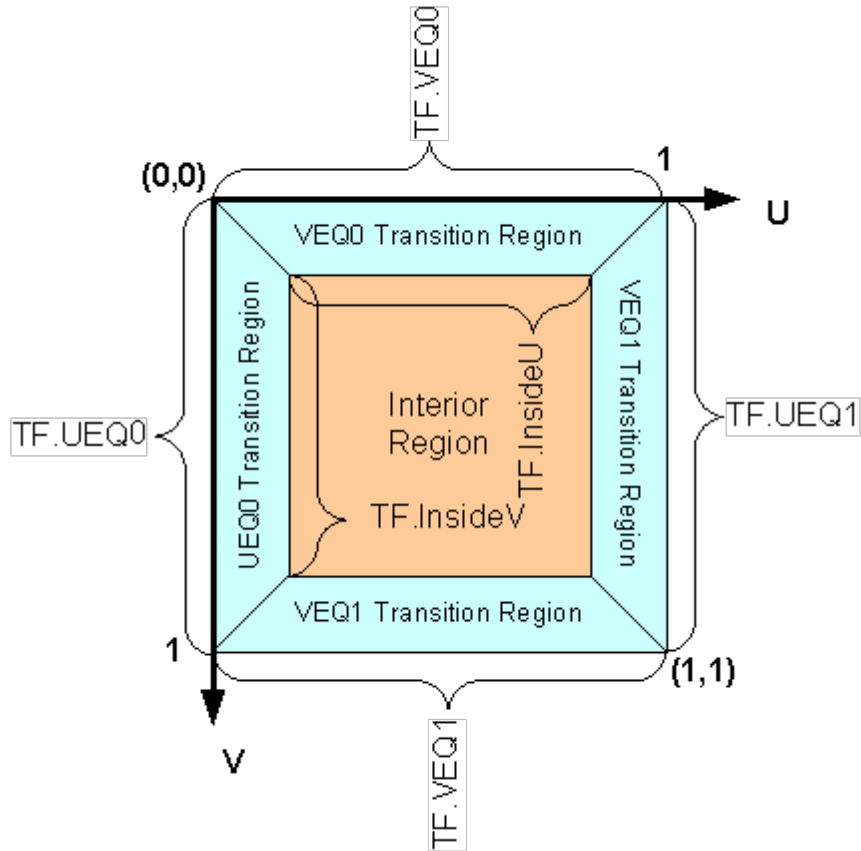

TRI Domain Tessellation

Tessellation of the TRI domain is similar to the QUAD domain, except only three outside edges/TFs are used, and the tessellation of the interior region is controlled by a single TF.

TRI Domain

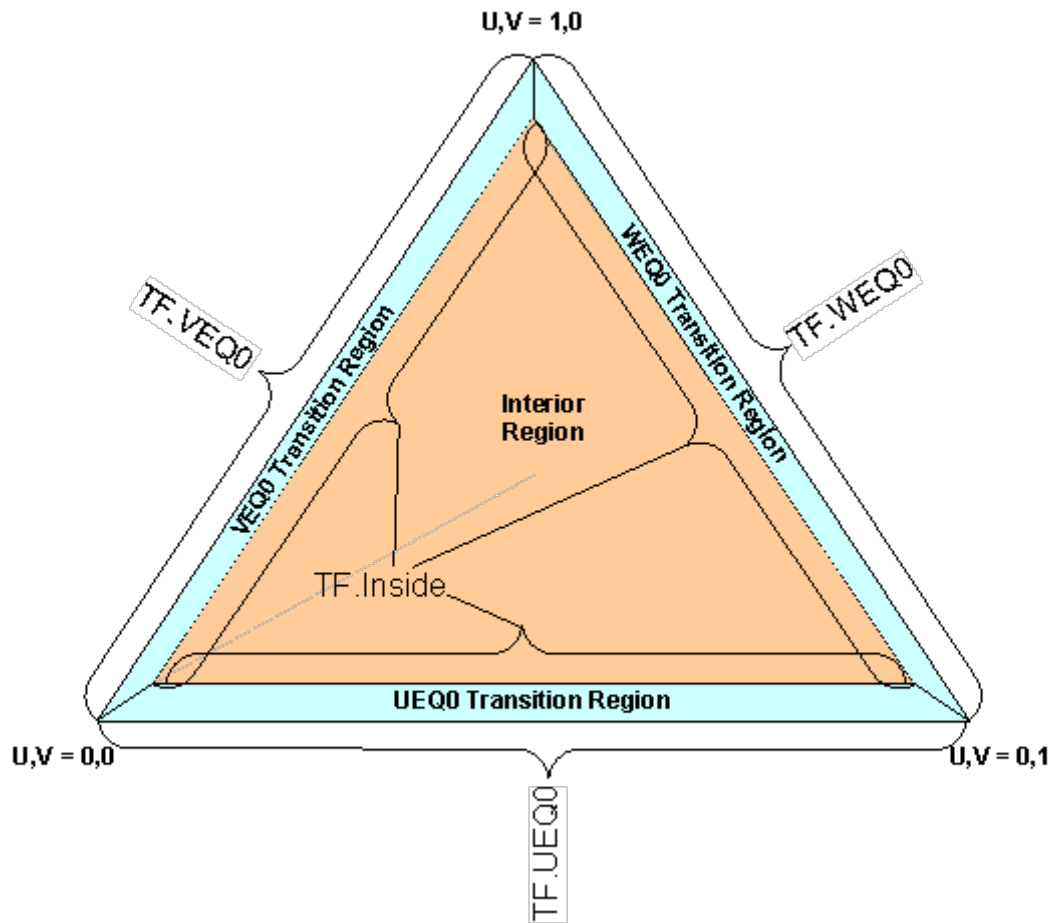

ISOLINE Domain Tessellation

Tessellation of the ISOLINE domain is different but much simpler than QUAD and TRI domains. The TF.LineDetail TF controls how finely the U direction is tessellated, while the TF.LineDensity TF controls how finely the V direction is tessellated. When LINE output topology is selected, a series of segmented lines parallel to the U axis (constant V) are output. When POINT output topology is selected, only the line segment endpoints are output (as point objects). In either case there is no topology output for the V=1 edge, which avoids overlapping lines for adjacent patches.

ISOLINE Domain

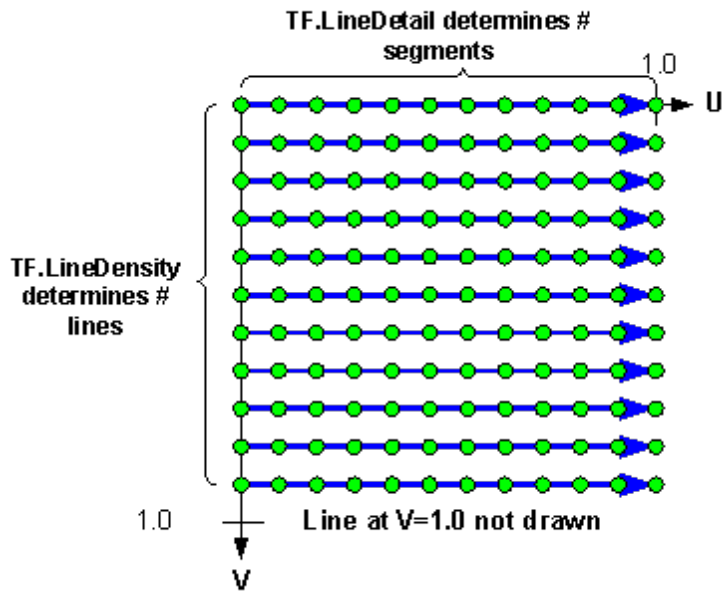



Domain Shader (DS) Stage

The DS stage is very similar to the VS stage in that it is responsible for dispatching EU threads to shade vertices and maintaining a cache (with reference counts) of the shaded vertex outputs of these threads. Major differences are as follows:

- The DS receives topologies with "domain points" instead of vertices. The only data specific to a domain point are its U,V coordinates. These coordinates (plus a default or computed W coordinate) are passed directly in the DS thread payload. There is no other vertex-specific "input vertex data".
- The concatenation of the domain point U,V coordinates (vs. a vertex index) is used as the cache tag.
- The cache is invalidated between patches.

The DS stage accepts state information via the inline 3DSTATE_DS command.

State

This section contains the state registers for the Domain Shader.

3DSTATE_DS

3DSTATE_PUSH_CONSTANT_ALLOC_DS

3DSTATE_CONSTANT_DS

3DSTATE_CONSTANT(Body)

3DSTATE_BINDING_TABLE_POINTERS_DS

3DSTATE_SAMPLER_STATE_POINTERS_DS

3DSTATE_URB_DS



Functions

SIMD4x2 Thread Execution

Project	Description
	A DS kernel assumes it is to operate on two domain points in parallel using the EU's SIMD4x2 execution model.

Refer to the ISA chapters for specifics on writing kernels that operate in SIMD4x2 fashion.

DS threads must always write the destination URB handles passed in the payload. DS threads are not permitted to request additional destination handles. Refer to *3D Pipeline Stage Overview (3D Overview)* for details on how destination vertices are written and any required contents/formats.

DS threads must signal thread termination on the last message output to the URB shared function.

Statistics Gathering

The DS stage maintains the DS_INVOCATIONS statistics counter, which counts the number of incoming domain points, irrespective of cache hit/miss. Note that this is different than VS_INVOCATIONS, which counts shader invocations and therefore doesn't count cache hits.



Payloads

SIMD4x2 Payload

The following table describes the payload delivered to DS threads.

DS Thread Payload (SIMD4x2)

DWord	Bits	Description				
R0.7	31					
	30:0	Reserved				
R0.6	31:24	Reserved				
	23:0	<p>Thread ID. This field uniquely identifies this thread within the threads spawned by this FF unit, over some period of time.</p> <p>Format: Reserved for HW Implementation Use.</p>				
R0.5	31:10	<p>Scratch Space Offset. Specifies the offset of the scratch space allocated to the thread, specified as a 1KB-granular offset from the General State Base Address. See Scratch Space Base Offset description in VS_STATE.</p> <p>(See <i>3D Pipeline</i> for further description on scratch space allocation).</p> <p>Format = GeneralStateOffset[31:10]</p>				
	9	<table border="1" style="width: 100%;"> <tr> <td style="width: 25%;">Project:</td> <td></td> </tr> <tr> <td colspan="2" style="text-align: center;">Reserved</td> </tr> </table>	Project:		Reserved	
	Project:					
Reserved						
8:0	<p>FFTID. This ID is assigned by the FF unit and used to identify the thread within the set of outstanding threads spawned by the FF unit.</p> <p>Format: Reserved for HW Implementation Use.</p> <p>Format = U9</p>					
R0.4	31:5	<p>Binding Table Pointer. Specifies the 32-byte aligned pointer to the Binding Table. It is specified as an offset from the Surface State Base Address.</p> <p>Format = SurfaceStateOffset[31:5]</p>				
	4:0	Reserved				
R0.3	31:5	<p>Sampler State Pointer. Specifies the location of the Sampler State Table to be used by this thread, specified as a 32-byte granular offset from the General State Base Address or Dynamic State Base Address.</p> <p>Format = DynamicStateOffset[31:5]</p>				
	4	Reserved				



DWord	Bits	Description				
	3:0	<p>Per Thread Scratch Space. Specifies the amount of scratch space allowed to be used by this thread. The value specifies the power that two will be raised to (over determine the amount of scratch space).</p> <p>Format = U4 power of two (in excess of 10)</p> <p>Range = [0,11] indicating [1K Bytes, 2M Bytes]</p>				
R0.2	31:0	Reserved: delivered as zeros (reserved for message header fields)				
R0.1	31:26	Reserved				
	25:16	<table border="1"> <thead> <tr> <th>Project</th> <th>Description</th> </tr> </thead> <tbody> <tr> <td></td> <td> <p>Handle ID 1. This ID is assigned by the FF unit and used to identify the URB Return Handle 1 to the FF unit (as FF-specific index value, not a URB address).</p> <p>If only one vertex is to be processed (shaded) by the thread, this field will effectively be ignored (no results are stored for these channels, as controlled by the thread's Channel Mask).</p> <p>Format = Reserved for HW Implementation Use.</p> </td> </tr> </tbody> </table>	Project	Description		<p>Handle ID 1. This ID is assigned by the FF unit and used to identify the URB Return Handle 1 to the FF unit (as FF-specific index value, not a URB address).</p> <p>If only one vertex is to be processed (shaded) by the thread, this field will effectively be ignored (no results are stored for these channels, as controlled by the thread's Channel Mask).</p> <p>Format = Reserved for HW Implementation Use.</p>
	Project	Description				
		<p>Handle ID 1. This ID is assigned by the FF unit and used to identify the URB Return Handle 1 to the FF unit (as FF-specific index value, not a URB address).</p> <p>If only one vertex is to be processed (shaded) by the thread, this field will effectively be ignored (no results are stored for these channels, as controlled by the thread's Channel Mask).</p> <p>Format = Reserved for HW Implementation Use.</p>				
15:14	Reserved					
13:0	<p>URB Return Handle 1: This is the URB handle where Vertex 1 data (the EU's upper channels (DWords 7:4)) results are to be stored.</p> <p>If only one vertex is to be processed (shaded) by the thread, this field will effectively be ignored (no results are stored for these channels, as controlled by the thread's Channel Mask).</p> <p>Format:</p> <table border="1"> <thead> <tr> <th>Project</th> <th>Format</th> </tr> </thead> <tbody> <tr> <td>HSW</td> <td>U13 handle (512-bit granular)</td> </tr> </tbody> </table>	Project	Format	HSW	U13 handle (512-bit granular)	
Project	Format					
HSW	U13 handle (512-bit granular)					
R0.0	31:26	Reserved				
	25:16	<table border="1"> <thead> <tr> <th>Project</th> <th>Description</th> </tr> </thead> <tbody> <tr> <td></td> <td> <p>Handle ID 0. This ID is assigned by the FF unit and used to identify the URB Return Handle 0 to the FF unit (as FF-specific index value, not a URB address).</p> <p>Format = Reserved for HW Implementation Use.</p> </td> </tr> </tbody> </table>	Project	Description		<p>Handle ID 0. This ID is assigned by the FF unit and used to identify the URB Return Handle 0 to the FF unit (as FF-specific index value, not a URB address).</p> <p>Format = Reserved for HW Implementation Use.</p>
	Project	Description				
	<p>Handle ID 0. This ID is assigned by the FF unit and used to identify the URB Return Handle 0 to the FF unit (as FF-specific index value, not a URB address).</p> <p>Format = Reserved for HW Implementation Use.</p>					
15:14	Reserved					



DWord	Bits	Description				
	13:0	<p>URB Return Handle 0: This is the URB handle where Vertex 0 data (the EU's lower channels (DWords 3:0)) results are to be stored.</p> <p>Format:</p> <table border="1"> <thead> <tr> <th>Project</th> <th>Format</th> </tr> </thead> <tbody> <tr> <td>HSW</td> <td>U13 handle (512-bit granular)</td> </tr> </tbody> </table>	Project	Format	HSW	U13 handle (512-bit granular)
Project	Format					
HSW	U13 handle (512-bit granular)					
R1.7	31:0	<p>PrimitiveID. This is the 32-bit PrimitiveID value associated with the patch. It is common to all output vertices resulting from the tessellation of the patch.</p> <p>Format: U32</p>				
R1.6	31:0	<p>Domain Point 1 W Coordinate. (See Domain Point 0 W Coordinate)</p> <p>Format: FLOAT32</p>				
R1.5	31:0	<p>Domain Point 1 V Coordinate. (See Domain Point 0 V Coordinate)</p> <p>Format: FLOAT32</p>				
R1.4	31:0	<p>Domain Point 1 U Coordinate. (See Domain Point 0 U Coordinate)</p> <p>Format: FLOAT32</p>				
R1.3	31:14	Reserved				
	13:0	<p>Patch URB Handle. This is the URB handle of the Patch Record (common to both vertices).</p> <p>Format:</p> <table border="1"> <thead> <tr> <th>Project</th> <th>Format</th> </tr> </thead> <tbody> <tr> <td>HSW</td> <td>U13 handle</td> </tr> </tbody> </table>	Project	Format	HSW	U13 handle
Project	Format					
HSW	U13 handle					
R1.2	31:0	<p>Domain Point 0 W Coordinate. If Compute W Coordinate Enable is set, this field will receive the computed value $(1 - U - V)$ for Domain Point 0. Otherwise it is passed as 0.0.</p> <p>Format: FLOAT32</p>				
R1.1	31:0	<p>Domain Point 0 V Coordinate. V coordinate associated with Domain Point 0.</p> <p>Format: FLOAT32</p>				
R1.0	31:0	<p>Domain Point 0 U Coordinate. U coordinate associated with Domain Point 0.</p> <p>Format: FLOAT32</p>				
Varies [Optional]	255:0	Constant Data (optional).				



DWord	Bits	Description
		<p>Some amount of constant data (possible none) can be extracted from the push constant buffer (PCB) and passed to the thread following the R0 Header. The amount of data provided is defined by the sum of the read lengths in the last 3DSTATE_CONSTANT_DS command (taking the buffer enables into account).</p> <p>The Constant Data arrives in a non-interleaved format.</p>
Varies [Optional]	255:0	<p>Patch URB Data (optional). Some amount of Patch Data (possible none) can be extracted from the URB and passed to the thread in this location in the payload. The amount of data provided is defined by the Patch URB Entry Read Length state (3DSTATE_DS).</p> <p>The Patch Data arrives in a non-interleaved format.</p>



3D Pipeline – Geometry Shader (GS) Stage

GS Stage Overview

The GS stage of the 3D Pipeline converts objects within incoming primitives into new primitives through use of a spawned thread. When enabled, the GS unit buffers incoming vertices, assembles the vertices of each individual object within the primitives, and passes those object vertices (along with other data) to the graphics subsystem for processing by a GS thread.

When the GS stage is disabled, vertices flow through the unit unmodified.

Refer to the *Common 3D FF Unit Functions* subsection in the *3D Pipeline* chapter for a general description of a 3D Pipeline stage, as much of the GS stage operation and control falls under these "common" functions. I.e., most stage state variables and GS thread payload parameters are described in *3D Pipeline*, and although they are listed here for completeness, that chapter provides the detailed description of the associated functions.

Refer to this chapter for an overall description of the GS stage, and any exceptions the GS stage exhibits with respect to common FF unit functions.

State

This sections contains the state registers for the Geometry Shader.

Project:	HSW
The state used by GS is defined with this inline state packet.	

3DSTATE_GS

3DSTATE_CONSTANT_GS

3DSTATE_CONSTANT(Body)

3DSTATE_PUSH_CONSTANT_ALLOC_GS

3DSTATE_BINDING_TABLE_POINTERS_GS

3DSTATE_SAMPLER_STATE_POINTERS_GS

3DSTATE_URB_GS



Functions

Object Staging

The GS unit's Object Staging Buffer (OSB) accepts primitive topologies as a stream of incoming vertices, and spawns a thread for each individual object within the topology.

Thread Request Generation

Object Vertex Ordering

The following table defines the number and order of object vertices passed in the Vertex Data portion of the GS thread payload, assuming an input topology with N vertices. The ObjectType passed to the thread is, by default, the incoming PrimTopologyType. Exceptions to this rule (for the TRISTRIP variants) are called out.

The following table also shows which vertex is selected to provide PrimitiveID (bold, underlined vertex number). In general, the vertex selected is the last vertex for non-adjacent prims, and the next-to-last vertex for adjacent prims. Note, however, that there are exceptions:

- reorder-enabled TRISTRIP[_REV], TRISTRIP_ADJ
- "odd-numbered" objects in TRISTRIP_ADJ

PrimTopologyType	Order of Vertices in Payload	GS Notes
<PRIMITIVE_TOPOLOGY> (N = # of vertices)	[<object#>] = (<vert#>,...); [{modified PrimType passed to thread}]	
POINTLIST	[0] = (<u>0</u>); [1] = (<u>1</u>); ...; [N-2] = (<u>N-2</u>);	
POINTLIST_BF	N/A	
LINELIST (N is multiple of 2)	[0] = (0, <u>1</u>); [1] = (2, <u>3</u>); ...; [(N/2)-1] = (N-2, <u>N-1</u>)	
LINELIST_ADJ (N is multiple of 4)	[0] = (0,1, <u>2</u> ,3); [1] = (4,5, <u>6</u> ,7); ...; [(N/4)-1] = (N-4,N-3, <u>N-2</u> ,N-1)	
LINESTRIP (N >= 2)	[0] = (0, <u>1</u>);	



PrimTopologyType	Order of Vertices in Payload	GS Notes
<PRIMITIVE_TOPOLOGY> (N = # of vertices)	[<object#>] = (<vert#>,...); [{modified PrimType passed to thread}]	
	[1] = (1,2); ...; [N-2] = (N-2,N-1)	
LINESTRIP_ADJ (N >= 4)	[0] = (0,1,2,3); [1] = (1,2,3,4); ...; [N-4] = (N-4,N-3,N-2,N-1)	
LINESTRIP_BF	N/A	
LINESTRIP_CONT	Same as LINESTRIP	Handled same as LINESTRIP
LINESTRIP_CONT_BF	Same as LINESTRIP	Handled same as LINESTRIP
LINELOOP (N >= 2)	[0] = (0,1); [1] = (1,2); [N] = (N-1,0);	Not supported after GS.
TRILIST (N is multiple of 3)	[0] = (0,1,2); [1] = (3,4,5); ...; [(N/3)-1] = (N-3,N-2,N-1)	
RECTLIST	Same as TRILIST	Handled same as TRILIST
TRILIST_ADJ (N is multiple of 6)	[0] = (0,1,2,3,4,5); [1] = (6,7,8,9,10,11); ...; [(N/6)-1] = (N-6,N-5,N-4,N-3,N-2,N-1)	
TRISTRIP (Reorder Leading) (N >= 3)	[0] = (0,1,2); {TRISTRIP} [1] = (1,3,2); {TRISTRIP_REV} [k even] = (k,k+1,k+2) {TRISTRIP} [k odd] = (k,k+2,k+1) {TRISTRIP_REV} [N-3] = (see above)	
TRISTRIP (Reorder Trailing) (N >= 3)	[0] = (0,1,2) {TRISTRIP}	"Odd" triangles have vertices reordered per OGL requirement, and identified as TRISTRIP_REV so the thread knows this.



PrimTopologyType	Order of Vertices in Payload	GS Notes
<PRIMITIVE_TOPOLOGY> (N = # of vertices)	[<object#>] = (<vert#>,...); [{modified PrimType passed to thread}]	
	[1] = (2,1,3) {TRISTRIP_REV}; ... [k even] = (k,k+1,k+2) {TRISTRIP} [k odd] = (k+1,k,k+2) {TRISTRIP_REV} [N-3] = (see above)	
TRISTRIP_REV (Reorder Leading) (N >= 3)	[0] = (0,2,1) {TRISTRIP_REV}; [1] = (1,2,3) {TRISTRIP}; ...; [k even] = (k,k+2,k+1) {TRISTRIP_REV} [k odd] = (k,k+1,k+2) {TRISTRIP} [N-3] = (see above)	
TRISTRIP_REV (Reorder Trailing) (N >= 3)	[0] = (1,0,2) {TRISTRIP_REV} [1] = (1,2,3) {TRISTRIP}; ...; [k even] = (k+1,k,k+2) {TRISTRIP_REV} [k odd] = (k,k+1,k+2) {TRISTRIP} [N-3] = (see above)	"Even" triangles have vertices reordered per OGL requirement, and identified as TRISTRIP_REV so the thread knows this.
TRISTRIP_ADJ (Reorder Leading) (N >= 6)	N = 6 or 7: [0] = (0,1,2,5,4,3) N = 8 or 9: [0] = (0,1,2,6,4,3); [1] = (2,5,6,7,4,0); ...; N >= 10: [0] = (0,1,2,6,4,3); [1] = (2,5,6,8,4,0); ...; [k>1, even] = (2k,2k-2, 2k+2, 2k+6,2k+4, 2k+3); [k>2, odd] = (2k, 2k+3, 2k+4,	



PrimTopologyType	Order of Vertices in Payload	GS Notes
<PRIMITIVE_TOPOLOGY> (N = # of vertices)	[<object#>] = (<vert#>,...); [{modified PrimType passed to thread}]	
	2k+6, 2k+2, 2k-2);...; Trailing object: [(N/2)-3, even] = (N-6,N-8,N-4,N-1, <u>N-2</u> ,N-3); [(N/2)-3, odd] = (N-6,N-3, <u>N-2</u> ,N-1,N-4,N-8);	
TRISTRIP_ADJ (Reorder Trailing) (N >= 6)	N = 6 or 7: [0] = (0,1,2,5, <u>4</u> ,3) N = 8 or 9: [0] = (0,1,2,6, <u>4</u> ,3); [1] = (4,0,2,5, <u>6</u> ,7); ...; N >= 10: [0] = (0,1,2,6, <u>4</u> ,3); [1] = (4,0,2,5, <u>6</u> ,8); ...; [k>1, even] = (2k,2k-2, 2k+2, 2k+6, <u>2k+4</u> , 2k+3); [k>2, odd] = (2k+2, 2k-2, 2k, 2k+3, <u>2k+4</u> , 2k+6);...; Trailing object: [(N/2)-3, even] = (N-6,N-8,N-4,N-1, <u>N-2</u> ,N-3); [(N/2)-3, odd] = (N-4,N-8,N-6,N-3, <u>N-2</u> ,N-1);	OpenGL ordering rules (last non-adjacent vertex is the last – aka provoking – vertex of the triangle). Even triangles have the same ordering as Leading Vertex, odd triangle ordering is different (rotated 2 vertices).
TRIFAN (N > 2)	[0] = (0,1, <u>2</u>); [1] = (0,2, <u>3</u>); ...; [N-3] = (0, N-2, <u>N-1</u>);	Only used by OGL
TRIFAN_NOSTIPPLE	Same as TRIFAN	
POLYGON	Same as TRIFAN	
	[0] = (0,1,2, <u>3</u>); [1] = (4,5,6, <u>7</u>); ...;	Not supported after GS. [DevSNB+]: QUADLIST primitives are converted into POLYGONS in VF, and therefore never reach



PrimTopologyType	Order of Vertices in Payload	GS Notes
<PRIMITIVE_TOPOLOGY> (N = # of vertices)	[<object#>] = (<vert#>,...); [{modified PrimType passed to thread}]	
	[(N/4)-1] = (N-4,N-3,N-2,N-1);	the GS.
	[0] = (0,1,3,2); [1] = (2,3,5,4); ... ; [(N/2)-2] = (N-4,N-3,N-1,N-2);	Not supported after GS. [DevSNB+]: QUADSTRIP primitives are converted into POLYGONS in VF, and therefore never reach the GS.
Project:	IVB+	
[DevIVB+]:	[0] = (0);	
PATCHLIST_1	[1] = (1); ...;	
PATCHLIST_2	[N-2] = (N-2);	
PATCHLIST_3..32	[0] = (0,1); [1] = (2,3); ...; [(N/2)-1] = (N-2,N-1) similar to above	

Thread Execution

A GS thread is capable of performing arbitrary algorithms given the thread payload (especially vertex) data and associated data structures (binding tables, sampler state, etc.) as input. Output can take the form of vertices output to the FF pipeline (at the GS unit) and/or data written to memory buffers via the DataPort.

The primary usage models for GS threads include (possible combinations of):

- Compiled application-provided *GS shader* programs, specifying an algorithm to convert the vertices of an input object into some output primitives. For example, a GS shader may convert lines of a line strip into polygons representing a corresponding segment of a blade of grass centered on the line. Or it could use adjacency information to detect silhouette edges of triangles and output polygons extruding out from the those edges. Or it could output absolutely nothing, effectively terminating the pipeline at the GS stage.
- Driver-generated instructions used to write pre-clipped vertices into memory buffers (see Stream Output below). This may be required whether or not an app-provided GS shader is enabled.
- Driver-generated instructions used to emulate API functions not supported by specialized hardware. These functions might include (but are not limited to):



- Conversion of API-defined topologies into topologies that can be rendered (e.g., LINELOOP →LINESTRIP, POLYGON →TRIFAN, QUADs →TRIFAN, etc.)
- Emulation of *Polygon Fill Mode*, where incoming polygons can be converted to points, lines (wireframe), or solid objects.
- Emulation of wide/sprite points.

When rendering is required, concurrent GS threads must use the FF_SYNC message (URB shared function) to request an initial VUE handle and synchronize output of VUEs to the pipeline (see *URB* in *Shared Functions*). Only one GS thread can be outputting VUEs to the pipeline at a time. To achieve parallelism, GS threads should perform the GS shader algorithm (along with any other required functions) and buffer results (either in the GRF or scratch memory) before issuing the FF_SYNC message. The issuing GS thread is stalled on the FF_SYNC writeback until it is that thread's turn to output VUEs. As only one GS thread at a time can output VUEs, the post-FF_SYNC output portion of the kernel should be optimized as much as possible to maximize parallelism.



Thread Execution

GS URB Entry

All outputs of a GS thread are stored in the single GS thread output URB entry. Cut (1 bit/vertex) or StreamID (2 bits/vertex) bits are packed into an optional 1-8 32B header. The **Control Data Format** and **Control Data Header Size** states specify the size and contents of the header data (if any).



Following the optional header is a variable number of 16B or 32B-aligned/granular vertices:

- When rendering is DISABLED, typically output vertices are 32B-aligned, with the exception of 16B-alignment for vertices $\leq 16B$ in length.
 - The absolute worst case size comes from three DW scalars output per vertex. If these are, say, three ".x" outputs, you need to store each DW in a 128b (16B) element, plus another pad 16B to keep the 32B alignment. So you require $4 \cdot 16B = 64B/\text{vertex}$. You have to have room for $1024 \text{ scalars} / 3 \text{ scalar/vtx} = 341 \text{ vertices}$. $341 \cdot 64B = 21,824B$. Then add 96B to hold 2b/vtx streamID and you get 21,920B entries.
- When rendering is ENABLED, each output vertex is 32B-aligned. Here the vertex header and vertex 'position' are required and therefore the minimum size vertex is 32B.
 - Here the worst case size isn't as bad as render-disabled, as you have to have a 4DW position output, plus any additional output. So, say you output 5 DW per vertex. You need 64B/vertex (16B vtx header, 16B position, 16B for the 2nd element, and 16B of pad). You have to have room for $1024 \text{ scalars} / 5 = 204 \text{ vertices}$. $204 \cdot 64 = 13,056B$. Then add 64B to hold 2b/vtx streamID and you get 13,120B entries.

The size of the URB entry should be based on the declared maximum # of output vertices and the declared output vertex size (the union of per-stream vertex structures, if required).



GS Output Topologies

The following table lists which primitive topology types are valid for output by a GS thread.

PrimTopologyType	Supported for GS Thread Output?
LINELIST	Yes
LINELIST_ADJ	No
LINESTRIP	Yes
LINESTRIP_ADJ	No
LINESTRIP_BF	Yes
LINESTRIP_CONT	Yes
LINESTRIP_CONT_BF	Yes
LINELOOP	No
POINTLIST	Yes
POINTLIST_BF	Yes
POLYGON	Yes
QUADLIST	No
QUADSTRIP	No
RECTLIST	Yes
TRIFAN	Yes
TRIFAN_NOSTIPPLE	Yes
TRILIST	Yes
TRILIST_ADJ	No
TRISTRIP	Yes
TRISTRIP_ADJ	No
TRISTRIP_REV	Yes
PATCHLIST_xxx	Yes

GS Output StreamID

When the **GS Enable** is DISABLED, output vertices are assigned a StreamID = 0;

When the **GS Enable** is ENABLED, output vertices are assigned a StreamID = **Default StreamID** under the following conditions:

- **Control Data Format** = 0, or
- **Control Data Format** > 0 and **Control Data Format** = GSCTL_CUT

When the GS is enabled, **Control Data Format** > 0 and **Control Data Format** = GSCTL_SID, output vertices are assigned a StreamID as programmed in the Control Data output by the thread.



Primitive Output

(This section refers to output from the GS unit to the pipeline, not output from the GS thread)

The GS unit will output primitives (either passed-through or generated by a GS thread) in the proper order. This includes the buffering of a concurrent GS thread's output until the preceding GS thread terminates. Note that the requirement to buffer subsequent GS thread output until the preceding GS thread terminates has ramifications on determining the number of VUEs allocated to the GS unit and the number of concurrent GS threads allowed.

Statistics Gathering

There are a number of GS/StreamOutput pipeline statistics counters associated with the GS stage and GS threads. This subsection describes these counters and controls depending on device, even in the cases where functions outside of the GS stage (e.g., DataPort) are involved in the statistics gathering.

Refer to the *Statistics Gathering* summary provided earlier in this specification. Refer to the *Memory Interface Registers* chapter for details on these MMIO pipeline statistics counter registers, as well as the chapters corresponding to the other functions involved (e.g., DataPort, URB shared functions).

GS Invocations

Payloads

Thread Payload High-Level Layout

Thread Payload High-Level Layout shows the high-level layout of the payload delivered to GS threads.



GS Dispatch Layouts

SINGLE, DUAL_INSTANCE GS Payload

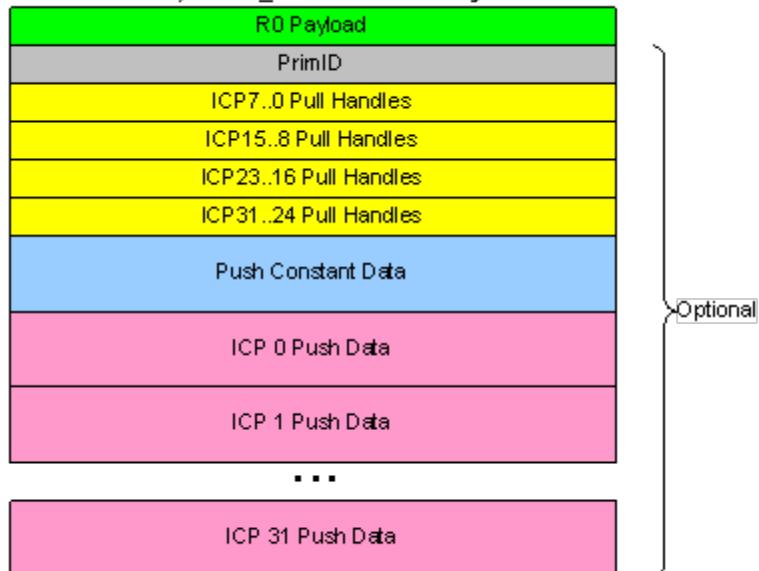

DUAL_OBJECT GS Payload

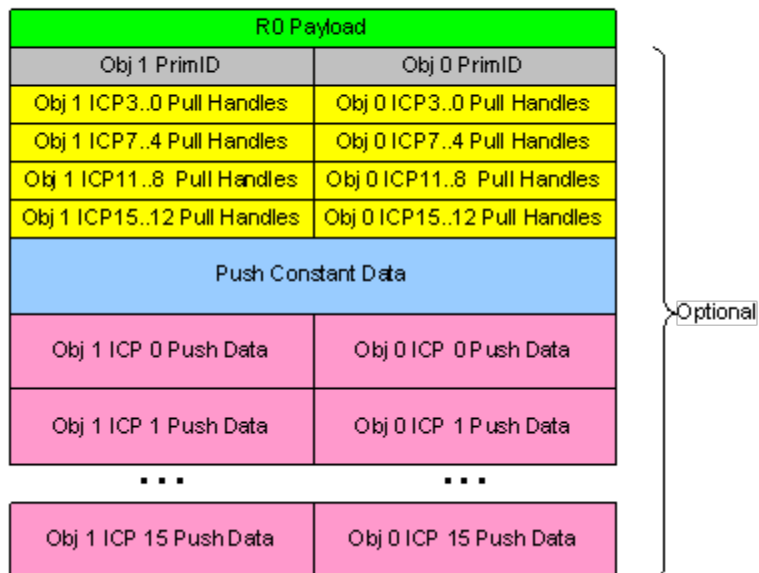

Subsequent sections provide detailed layouts for different processor generations.



SIMD 4x2 Thread Payload

The table below shows the layout of the payload delivered to GS threads.

Refer to [3D Pipeline Stage Overview](#) for details on fields that are common among the various pipeline stages.

GRF DWord	Bits	Description							
R0.7	31								
	30:0	Reserved.							
R0.6	31	Dereference Thread. This bit is defined to send back the Handle ID back to HS to dereference the input handles for this thread.							
	30:24	Reserved.							
	23:0	Thread ID. This field uniquely identifies this thread within the threads spawned by this FF unit, over some period of time. Format: Reserved for HW Implementation Use.							
R0.5	31:10	Scratch Space Pointer. Specifies the location of the scratch space allocated to this thread, specified as a 1KB-aligned offset from the General State Base Address . Format = GeneralStateOffset[31:10]							
	9:0	Reserved							
	8:0	FFTID. This ID is assigned by the fixed function unit and is relative identifier for the thread. It is used to free up resources used by the thread upon thread completion. Format: <table border="1" data-bbox="354 1291 1495 1377"> <thead> <tr> <th>Project</th> <th>Format</th> </tr> </thead> <tbody> <tr> <td>HSW</td> <td>U8</td> </tr> </tbody> </table> Range: <table border="1" data-bbox="354 1444 1495 1530"> <thead> <tr> <th>Project</th> <th>Range</th> </tr> </thead> <tbody> <tr> <td>HSW</td> <td>0-255</td> </tr> </tbody> </table>	Project	Format	HSW	U8	Project	Range	HSW
Project	Format								
HSW	U8								
Project	Range								
HSW	0-255								
R0.4	31:5	Binding Table Pointer: Specifies the 32-byte aligned pointer to the Binding Table. It is specified as an offset from the Surface State Base Address . Format = SurfaceStateOffset[31:5]							
	4:0	Reserved.							
R0.3	31:5	Sampler State Pointer. Specifies the location of the Sampler State Table used by this thread, specified as a 32-byte granular offset from the Dynamic State Base Address . Format = DynamicStateOffset[31:5]							



GRF DWord	Bits	Description			
	4	Reserved.			
	3:0	<p>Per Thread Scratch Space. Specifies the amount of scratch space allowed for this thread. The value specifies the power that two is raised to (over determine the amount of scratch space).</p> <p>Programming Notes:</p> <p>This amount is available to the kernel for information only. It is passed verbatim (if not altered by the kernel) to the Data Port in any scratch space access messages, but the Data Port ignores it.</p> <p>Format = U4 power of two (in excess of 10)</p> <p>Range = [0,11] indicating [1K Bytes, 2M Bytes]</p>			
R0.2	31:24	<p>Semaphore Index. This is a DWord index used in URB_ATOMIC commands if the thread is using data pulled from input handles. This information is only required for pull-model vertex inputs and InstanceCount > 1.</p> <p>Format = U8</p>			
	23	Reserved.			
	22	<p>Hint. This is a copy of the corresponding 3DSTATE_GS bit.</p> <p>Format: U1</p>			
	21:16	<p>Primitive Topology Type. This field identifies the Primitive Topology Type associated with the primitive containing this object. It indirectly specifies the number of input vertices included in the thread payload. Note that the GS unit may toggle this value between TRISTRIP and TRISTRIP_REV. If the Discard Adjacency bit is set, the topology type passed in the payload is UNDEFINED.</p> <p>Format: See <i>3D Pipeline</i>.</p>			
	15:13	Reserved			
	12:0	<p>Semaphore Handle. This is the URB offset pointing to the first GS semaphore DWord in the URB. Software is responsible for statically allocating the semaphore DWords in the URB. Refer to Semaphore Handle field in 3DSTATE_GS for size of semaphore allocation.</p> <p>Format:</p> <table border="1" data-bbox="350 1570 1490 1661"> <thead> <tr> <th>Project</th> <th>Format</th> </tr> </thead> <tbody> <tr> <td>HSW</td> <td>U13 64B-aligned URB offset.</td> </tr> </tbody> </table>	Project	Format	HSW
Project	Format				
HSW	U13 64B-aligned URB offset.				
R0.1	31:27	<p>GS Instance ID 1. For each input object, the GS unit can spawn multiple threads (instances). This field starts at zero for the first instance of an object and increments for subsequent instances.</p> <p>If "dispatch mode" is DUAL_OBJECT this field is not valid.</p> <p>Format: U5</p>			
	26:16	Reserved.			



GRF DWord	Bits	Description				
	15:0	<p>URB Return Handle 1. This is the URB offset where the EU's upper channels (DWords 7:4) results are stored.</p> <p>If only one object/instance is processed (shaded) by the thread, this field is effectively ignored (no results are stored for these channels, as controlled by the thread's Channel Mask).</p> <p>Format:</p> <table border="1"> <thead> <tr> <th>Project</th> <th>Format</th> </tr> </thead> <tbody> <tr> <td>HSW</td> <td>U13 64B-aligned URB offset.</td> </tr> </tbody> </table>	Project	Format	HSW	U13 64B-aligned URB offset.
Project	Format					
HSW	U13 64B-aligned URB offset.					
R0.0	31:27	<p>GS Instance ID 0. For each input object, the GS unit can spawn multiple threads (instances). This field starts at zero for the first instance of an object and increments for subsequent instances.</p> <p>If "dispatch mode" is DUAL_OBJECT, this field is not valid.</p> <p>Format: U5</p>				
	26:16	Reserved.				
	15:0	<p>URB Return Handle 0. This is the URB offset where the EU's lower channels (DWords 3:0) results are stored.</p> <p>Format:</p> <table border="1"> <thead> <tr> <th>Project</th> <th>Format</th> </tr> </thead> <tbody> <tr> <td>HSW</td> <td>U13 64B-aligned URB offset.</td> </tr> </tbody> </table>	Project	Format	HSW	U13 64B-aligned URB offset.
Project	Format					
HSW	U13 64B-aligned URB offset.					
The following register is included only if Include PrimitiveID is enabled.						
R1.7-R1.5	31:0	Reserved: MBZ.				
R1.4	31:0	<p>Primitive ID 1. This field contains the Primitive ID associated with (all instances) of input object 1. Only valid in DUAL_OBJECT mode.</p> <p>Format: U32</p>				
R1.3-R1.1	31:0	Reserved: MBZ.				
R1.0	31:0	<p>Primitive ID 0. This field contains the Primitive ID associated with (all instances) of input object 0.</p> <p>Format: U32</p>				
The following register is included only if SINGLE or DUAL_INSTANCE mode and Include Vertex Handles is enabled.						
Rn.7	31:16	ICP 7 Handle ID				
	15:0	ICP 7 Handle				
Rn.6	31:16	ICP 6 Handle ID				
	15:0	ICP 6 Handle				
Rn.5	31:16	ICP 5 Handle ID				
	15:0	ICP 5 Handle				



GRF DWord	Bits	Description
Rn.4	31:16	ICP 4 Handle ID
	15:0	ICP 4 Handle
Rn.3	31:16	ICP 3 Handle ID
	15:0	ICP 3 Handle
Rn.2	31:16	ICP 2 Handle ID
	15:0	ICP 2 Handle
Rn.1	31:16	ICP 1 Handle ID
	15:0	ICP 1 Handle
Rn.0	31:16	ICP 0 Handle ID
	15:0	ICP 0 Handle
The following register is included only if SINGLE or DUAL_INSTANCE mode and Include Vertex Handles is enabled and ICP Count > 7.		
Rn+1.7	31:16	ICP 15 Handle ID
	15:0	ICP 15 Handle
Rn+1.6	31:16	ICP 14 Handle ID
	15:0	ICP 14 Handle
Rn+1.5	31:16	ICP 13 Handle ID
	15:0	ICP 13 Handle
Rn+1.4	31:16	ICP 12 Handle ID
	15:0	ICP 12 Handle
Rn+1.3	31:16	ICP 11 Handle ID
	15:0	ICP 11 Handle
Rn+1.2	31:16	ICP 10 Handle ID
	15:0	ICP 10 Handle
Rn+1.1	31:16	ICP 9 Handle ID
	15:0	ICP 9 Handle
Rn+1.0	31:16	ICP 8 Handle ID
	15:0	ICP 8 Handle
The following register is included only if SINGLE or DUAL_INSTANCE mode and Include Vertex Handles is enabled and ICP Count > 15.		
Rn+2.7	31:16	ICP 23 Handle ID
	15:0	ICP 23 Handle
Rn+2.6	31:16	ICP 22 Handle ID
	15:0	ICP 22 Handle
Rn+2.5	31:16	ICP 21 Handle ID
	15:0	ICP 21 Handle



GRF DWord	Bits	Description
Rn+2.4	31:16	ICP 20 Handle ID
	15:0	ICP 20 Handle
Rn+2.3	31:16	ICP 19 Handle ID
	15:0	ICP 19 Handle
Rn+2.2	31:16	ICP 18 Handle ID
	15:0	ICP 18 Handle
Rn+2.1	31:16	ICP 17 Handle ID
	15:0	ICP 17 Handle
Rn+2.0	31:16	ICP 16 Handle ID
	15:0	ICP 16 Handle
The following register is included only if SINGLE or DUAL_INSTANCE mode and Include Vertex Handles is enabled and ICP Count > 23.		
Rn+3.7	31:16	ICP 31 Handle ID
	15:0	ICP 31 Handle
Rn+3.6	31:16	ICP 30 Handle ID
	15:0	ICP 30 Handle
Rn+3.5	31:16	ICP 29 Handle ID
	15:0	ICP 29 Handle
Rn+3.4	31:16	ICP 28 Handle ID
	15:0	ICP 28 Handle
Rn+3.3	31:16	ICP 27 Handle ID
	15:0	ICP 27 Handle
Rn+3.2	31:16	ICP 26 Handle ID
	15:0	ICP 26 Handle
Rn+3.1	31:16	ICP 25 Handle ID
	15:0	ICP 25 Handle
Rn+3.0	31:16	ICP 24 Handle ID
	15:0	ICP 24 Handle
The following register is included only if DUAL_OBJECT mode and Include Vertex Handles is enabled.		
Rn.7	31:16	Object 1 ICP 3 Handle ID
	15:0	Object 1 ICP 3 Handle
Rn.6	31:16	Object 1 ICP 2 Handle ID
	15:0	Object 1 ICP 2 Handle
Rn.5	31:16	Object 1 ICP 1 Handle ID
	15:0	Object 1 ICP 1 Handle



GRF DWord	Bits	Description
Rn.4	31:16	Object 1 ICP 0 Handle ID
	15:0	Object 1 ICP 0 Handle
Rn.3	31:16	Object 0 ICP 3 Handle ID
	15:0	Object 0 ICP 3 Handle
Rn.2	31:16	Object 0 ICP 2 Handle ID
	15:0	Object 0 ICP 2 Handle
Rn.1	31:16	Object 0 ICP 1 Handle ID
	15:0	Object 0 ICP 1 Handle
Rn.0	31:16	Object 0 ICP 0 Handle ID
	15:0	Object 0 ICP 0 Handle
The following register is included only if DUAL_OBJECT mode and Include Vertex Handles is enabled and ICP Count > 3.		
Rn+1.7	31:16	Object 1 ICP 7 Handle ID
	15:0	Object 1 ICP 7 Handle
Rn+1.6	31:16	Object 1 ICP 6 Handle ID
	15:0	Object 1 ICP 6 Handle
Rn+1.5	31:16	Object 1 ICP 5 Handle ID
	15:0	Object 1 ICP 5 Handle
Rn+1.4	31:16	Object 1 ICP 4 Handle ID
	15:0	Object 1 ICP 4 Handle
Rn+1.3	31:16	Object 0 ICP 7 Handle ID
	15:0	Object 0 ICP 7 Handle
Rn+1.2	31:16	Object 0 ICP 6 Handle ID
	15:0	Object 0 ICP 6 Handle
Rn+1.1	31:16	Object 0 ICP 5 Handle ID
	15:0	Object 0 ICP 5 Handle
Rn+1.0	31:16	Object 0 ICP 4 Handle ID
	15:0	Object 0 ICP 4 Handle
The following register is included only if DUAL_OBJECT mode and Include Vertex Handles is enabled and ICP Count > 7.		
Rn+2.7	31:16	Object 1 ICP 11 Handle ID
	15:0	Object 1 ICP 11 Handle
Rn+2.6	31:16	Object 1 ICP 10 Handle ID
	15:0	Object 1 ICP 10 Handle
Rn+2.5	31:16	Object 1 ICP 9 Handle ID
	15:0	Object 1 ICP 9 Handle



GRF DWord	Bits	Description
Rn+2.4	31:16	Object 1 ICP 8 Handle ID
	15:0	Object 1 ICP 8 Handle
Rn+2.3	31:16	Object 0 ICP 11 Handle ID
	15:0	Object 0 ICP 11 Handle
Rn+2.2	31:16	Object 0 ICP 10 Handle ID
	15:0	Object 0 ICP 10 Handle
Rn+2.1	31:16	Object 0 ICP 9 Handle ID
	15:0	Object 0 ICP 9 Handle
Rn+2.0	31:16	Object 0 ICP 8 Handle ID
	15:0	Object 0 ICP 8 Handle
The following register is included only if DUAL_OBJECT mode and Include Vertex Handles is enabled and ICP Count > 11.		
Rn+3.7	31:16	Object 1 ICP 15 Handle ID
	15:0	Object 1 ICP 15 Handle
Rn+3.6	31:16	Object 1 ICP 14 Handle ID
	15:0	Object 1 ICP 14 Handle
Rn+3.5	31:16	Object 1 ICP 13 Handle ID
	15:0	Object 1 ICP 13 Handle
Rn+3.4	31:16	Object 1 ICP 12 Handle ID
	15:0	Object 1 ICP 12 Handle
Rn+3.3	31:16	Object 0 ICP 15 Handle ID
	15:0	Object 0 ICP 15 Handle
Rn+3.2	31:16	Object 0 ICP 14 Handle ID
	15:0	Object 0 ICP 14 Handle
Rn+3.1	31:16	Object 0 ICP 13 Handle ID
	15:0	Object 0 ICP 13 Handle
Rn+3.0	31:16	Object 0 ICP 12 Handle ID
	15:0	Object 0 ICP 12 Handle
Varies (optional)	31:0	Constant Data (optional): Some amount of constant data (possibly none) can be extracted from the push constant buffer (PCB) and passed to the thread following the R0 Header. The amount of data provided is defined by the sum of the read lengths in the last 3DSTATE_CONSTANT_GS command (taking the buffer enables into account). The Constant Data arrives in a non-interleaved format.
Varies	31:0	Pushed Vertex Data. There can be up to 32 vertices supplied, each with a size defined by the Vertex URB Entry Read Length state. The amount of data provided for each vertex is defined by



GRF DWord	Bits	Description
		<p>the Vertex URB Entry Read Length state.</p> <p>For SINGLE or DUAL_INSTANCE dispatch modes, the pushed data for Vertex 0 immediately follows any pushed constant data. The pushed data for Vertex 1 immediately follows Vertex 0, and so on. There is no upper/lower swizzling of data.</p> <p>For DUAL_OBJECT dispatch mode, the pushed vertex data is split into upper and lower halves with Object 0 input vertices in the lower half, and Object 1 input vertices in the upper half.</p>



Thread Request Generation

Once a FF unit determines that a thread can be requested, it must gather all the information required to submit the thread request to the Thread Dispatcher. This information is divided into several categories, as listed below and subsequently described in detail.

- **Thread Control Information:** This is the information required (from the FF unit) to establish the execution environment of the thread.
- **Thread Payload Header:** This is the first portion of the thread payload passed in the GRF, starting at GRF R0. This is information passed directly from the FF unit. It precedes the Thread Payload Input URB Data.
- **Thread Payload Input URB Data:** This is the second portion of the thread payload. It is read from the URB using entry handles supplied by the FF unit.

Thread Control Information

The following table describes the various state variables that a FF unit uses to provide information to the Thread Dispatcher and which affect the thread execution environment. Note that this information is not directly passed to the thread in the thread payload (though some fields may be subsequently accessed by the thread via architectural registers).

State Variables Included in Thread Control Information

State Variable	Usage	FFs
Kernel Start Pointer	This field, together with the General State Pointer , specifies the starting location (1 st GEN4 core instruction) of the kernel program run by threads spawned by this FF unit. It is specified as a 64-byte-granular offset from the General State Pointer .	All FFs spawning threads
GRF Register Block Count	Specifies, in 16-register blocks, how many GRF registers are required to run the kernel. The Thread Dispatcher will only seek candidate EUs that have a sufficient number of GRF register blocks available. Upon selecting a target EU, the Thread Dispatcher will generate a logical-to-physical GRF mapping and provide this to the target EU.	All FFs spawning threads
Single Program Flow (SPF)	Specifies whether the kernel program has a single program flow (SIMD _n x _m with $m = 1$) or multiple program flows (SIMD _n x _m with $m > 1$). See CR0 description in <i>ISA Execution Environment</i> .	All FFs spawning threads
Thread Dispatch Priority	The Thread Dispatcher will give priority to those thread requests with Thread Dispatch Priority of HIGH_PRIORITY over those marked as LOW_PRIORITY. Within these two classes of thread requests, the Thread Dispatcher applies a priority order (e.g., round-robin --- though this algorithm is considered a device implementation-dependent detail).	All FFs spawning threads
Floating	This determines the initial value of the Floating Point Mode bit of the EU's CR0	All FFs spawning



State Variable	Usage	FFs
Point Mode	architectural register that controls floating point behavior in the EU core. (See ISA.)	threads
Exceptions Enable	This bitmask controls the exception handling logic in the EU. (See ISA.)	All FFs spawning threads
Sampler Count	This is a <i>hint</i> which specifies how many indirect SAMPLER_STATE structures should be prefetched concurrent with thread initiation. It is recommended that software program this field to equal the number of samplers, though there may be some minor performance impact if this number gets large. This value should not exceed the number of samplers accessed by the thread as there would be no performance advantage. Note that the data prefetch is treated as any other memory fetch (with respect to page faults, etc.).	All stages supporting sampling (VS, GS, WM)
Binding Table Entry Count	This is a <i>hint</i> which specifies how many indirect BINDING_TABLE_STATE structures should be prefetched concurrent with thread initiation. (The notes included in Sampler Count (above) also apply to this field).	All FFs spawning threads

Thread Payload Generation

FF units are responsible for generating a thread *payload* – the data pre-loaded into the target EU's GRF registers (starting at R0) that serves as the primary direct input to a thread's kernel. The general format of these payloads follow a similar structure, though the exact payload size/content/layout is unique to each stage. This subsection describes the common aspects – refer to the specific stage's chapters for details on any differences.

The payload data is divided into two main sections: the *payload header* followed by the *payload URB data*. The payload header contains information passed directly from the FF unit, while the payload URB data is obtained from URB locations specified by the FF unit.

NOTE: The first 256 bits of the thread payload (the initial contents of R0, aka *the R0 header*) is specially formatted to closely match (and in some cases exactly match) the first 256 bits of thread-generated *messages* (i.e., the message header) accepted by shared functions. In fact, the send instruction supports having a copy of a GR's contents (such as R0) used as the message header. Software must take this intention into account (i.e., *don't muck with R0 unless you know what you're doing*). This is especially important given the fact that several fields in the R0 header are considered opaque to SW, where use or modification of their contents might lead to UNDEFINED results.

The payload header is further (loosely) divided into a leading *fixed payload header* section and a trailing, variable-sized *extended payload header* section. In general the size, content and layout of both payload header sections are FF-specific, though many of the fixed payload header fields are common amongst the FF stages. The extended header is used by the FF unit to pass additional information specific to that FF unit. The extended header is defined to start after the fixed payload header and end at the offset defined by **Dispatch GRF Start Register for URB Data**. Software can cause use the **Dispatch GRF Start**



Register for URB Data field to insert padding into the extended header in order to maintain a fixed offset for the start of the URB data.

Fixed Payload Header

The payload header is used to pass *FF pipeline information* required as thread input data. This information is a mixture of SW-provided state information (state table pointers, etc.), primitive information received by the FF unit from the FF pipeline, and parameters generated/computed by the FF unit. Most of the fields of the fixed header are common between the FF stages. These non-FF-specific fields are described in Fixed Payload Header Fields (non-FF-specific). Note that a particular stage's header may not contain all these fields, so they are not "common" in the strictest sense.

Fixed Payload Header Fields (non-FF-specific)

Fixed Payload Header Field (non-FF-specific)	Description	FFs
FF Unit ID	Function ID of the FF unit. This value identifies the FF unit within the GEN4 subsystem. The FF unit uses this field (when transmitted in a Message Header to the URB Function) to detect messages emanating from its spawned threads.	All FFs spawning threads
Snapshot Flag		All FFs spawning threads
Thread ID	This field uniquely identifies this thread within the FF unit over some period of time.	All FFs spawning threads
Scratch Space Pointer	This is the starting location of the thread's allocated scratch space, specified as an offset from the General State Base Address . Note that scratch space is allocated by the FF unit on a per-thread basis, based on the Scratch Space Base Pointer and Per-Thread Scratch Space Size state variables. FF units assign a thread an arbitrarily-positioned region within this space. The scratch space for multiple (API-visible) entities (vertices, pixels) is interleaved within the thread's scratch space.	All FFs spawning threads
Dispatch ID	This field identifies this thread within the outstanding threads spawned by the FF unit. This field does <i>not</i> uniquely identify the thread over any significant period of time. Implementation Note: This field is effectively an "active thread index". It is used on a thread's URB allocation request to identify which thread's handle pool is to source the allocation. It is used upon thread termination to free up the thread's scratch space allocation.	All FFs spawning threads



Fixed Payload Header Field (non-FF-specific)	Description	FFs
Binding Table Pointer	<p>This field, together with the Surface State Base Pointer, specifies the starting location of the Binding Table used by threads spawned by the FF unit. It is specified as a 64-byte-granular offset from the Surface State Base Pointer.</p> <p>See <i>Shared Functions</i> for a description of a Binding Table.</p>	All FFs spawning threads
Sampler State Pointer	<p>This field, together with the General State Base Pointer, specifies the starting location of the Sampler State Table used by threads spawned by the FF unit. It is specified as a 64-byte-granular offset from the General State Base Pointer.</p> <p>See <i>Shared Functions</i> for a description of a Sampler State Table.</p>	All FFs spawning threads which sample (VS, GS, WM)
Per Thread Scratch Space	<p>This field specifies the amount of scratch space allocated to each thread spawned by the FF unit.</p> <p>The driver must allocate enough contiguous scratch space, starting at the Scratch Space Base Pointer, to ensure that the Maximum Number of Threads can each get Per-Thread Scratch Space size without exceeding the driver-allocated scratch space.</p>	All FFs spawning threads
Handle ID <n>	<p>This ID is assigned by the FF unit and links the thread to a specific entry within the FF unit. The FF unit will use this information upon detecting a URB_WRITE message issued by the thread.</p> <p>Threads spawned by the GS, CLIP, and SF units are provided with a single Handle ID / URB Return Handle pair. Threads spawned by the VS are provided with one or two pairs (depending on how many vertices are to be processed). Threads spawned by the WM do not write to URB entries, and therefore this info is not supplied.</p>	VS, GS, CLIP, SF
URB Return Handle <n>	<p>This is an initial destination URB handle passed to the thread. If the thread does output URB entries, this identifies the destination URB entry.</p> <p>Threads spawned by the GS, CLIP, and SF units are provided with a single Handle ID / URB Return Handle pair. Threads spawned by the VS are provided with one or two pairs (depending on how many vertices are to be processed). Threads spawned by the WM do not write to URB entries, and therefore this info is not supplied.</p>	VS, GS, CLIP, SF



Fixed Payload Header Field (non-FF-specific)	Description	FFs
Primitive Topology Type	<p>As part of processing an incoming primitive, a FF unit is often required to spawn a number of threads (e.g., for each individual triangle in a TRIANGLE_STRIP). This field identifies the type of primitive which is being processed by the FF unit, and which has lead to the spawning of the thread.</p> <p>GEN4 kernels written to process different types of objects can use this value to direct that processing. E.g., when a CLIP kernel is to provide clipping for all the various primitive types, the kernel would need to examine the Primitive Topology Type to distinguish between point, lines, and triangle clipping requests.</p> <p>Note: In general, this field is identical to the Primitive Topology Type associated with the primitive vertices as received by the FF unit. Refer to the individual FF unit chapters for cases where the FF unit modifies the value before passing it to the thread. (E.g., certain units perform toggling of TRIANGLESTRIP and TRIANGLESTRIP_REV).</p>	GS, CLIP, SF, WM

Extended Payload Header

The extended header is of variable-size, where inclusion of a field is determined by FF unit state programming.

In order to permit the use of common kernels (thus reducing the number of kernels required), the **Dispatch GRF Start Register for URB Data** state variable is supported in all FF stages. This SV is used to place the payload URB data at a specific starting GRF register, irrespective of the size of the extended header. A kernel can therefore reference the payload URB data at fixed GRF locations, while conditionally referencing extended payload header information.

Payload URB Data

In each thread payload, following the payload header, is some amount of URB-sourced data required as input to the thread. This data is divided into an optional *Constant URB Entry* (CURBE), following either by a Primitive URB Entry (WM) or a number of Vertex URB Entries (VS, GS, CLIP, SF). A FF unit only knows the location of this data in the URB, and is never exposed to the contents. For each URB entry, the FF unit will supply a sequence of handles, read offsets and read lengths to the GEN4 subsystem. The subsystem will read the appropriate 256-bit locations of the URB, optionally perform swizzling (VS only), and write the results into sequential GRF registers (starting at **Dispatch GRF Start Register for URB Data**).



State Variables Controlling Payload URB Data

State Variable	Usage	FFs
Dispatch GRF Start Register for URB Data	This SV identifies the starting GRF register receiving payload URB data. Software is responsible for ensuring that URB data does not overwrite the Fixed or Extended Header portions of the payload.	FFs spawning threads
Vertex URB Entry Read Offset	This SV specifies the starting offset within VUEs from which vertex data is to be read and supplied in this stage's payloads. It is specified as a 256-bit offset into any and all VUEs passed in the payload. This SV can be used to skip over leading data in VUEs that is not required by the stage's threads (e.g., skipping over the Vertex Header data at the SF stage, as that information is not required for setup calculations). Skipping over irrelevant data can only help to improve performance. Specifying a vertex data source extending beyond the end of a vertex entry is UNDEFINED.	
Vertex URB Entry Read Length	This SV determines the amount of vertex data (starting at Vertex URB Entry Read Offset) to be read from each VUEs and passed into the payload URB data. It is specified in 256-bit units. A zero value is INVALID (at very least one 256-bit unit must be read). Specifying a vertex data source extending beyond the end of a VUE is UNDEFINED.	

Programming Restrictions: (others may already been mentioned)

- The maximum size payload for any thread is limited by the number of GRF registers available to the thread, as determined by $\min(128, 16 * \text{GRF Register Block Count})$. Software is responsible for ensuring this maximum size is not exceeded, taking into account:
 - The size of the Fixed and Extended Payload Header associated with the FF unit.
 - The **Dispatch GRF Start Register for URB Data** SV.
 - The amount of CURBE data included (via **Constant URB Entry Read Length**)
 - The number of VUEs included (as a function of FF unit, its state programming, and incoming primitive types)
 - The amount of VUE data included for each vertex (via **Vertex URB Entry Read Length**)
 - (For WM-spawned PS threads) The amount of Primitive URB Entry data.
- For any type of URB Entry reads:
 - Specifying a source region (via Read Offset, Read Length) that goes past the end of the URB Entry allocation is illegal.
 - The allocated size of Vertex/Primitive URB Entries is determined by the **URB Entry Allocation Size** value provided in the pipeline state descriptor of the FF unit owning the VUE/PUE.
 - The allocated size of CURBE entries is determined by the **URB Entry Allocation Size** value provided in the CS_URB_STATE command.



3D Pipeline - Stream Output Logic (SOL) Stage

The Stream Output Logic (SOL) stage receives 3D topologies originating in the VF or GS stage. If enabled, the SOL stage uses programmed state information to copy portions of the vertex data associated with the incoming topologies across one or more Stream Output (SO) Buffers.

State

This section contains registers and commands for the 3D State Streamout.

3DSTATE_STREAMOUT

The 3DSTATE_STREAMOUT command specifies control information for the SOL stage. Included are enables and sizes for input streams and enables for output buffers.

The SOL unit incorrectly double buffers MMIO/NP registers and only moves them into the design for usage when control topology is received with the SOL unit dirty state.

If the state does not change, need to resend the same state.

Project:	HSW
There is no need to send a pipeline state update to the SOL unit after SOL unit MMIO registers or non-pipeline state are written.	

3DSTATE_STREAMOUT

3DSTATE_SO_DECL_LIST Command

The 3DSTATE_SO_DECL_LIST instruction defines a list of Stream Output (SO) declaration entries (SO_DECLs) and associated information for all specific SO streams in parallel.

3DSTATE_SO_DECL_LIST

SO_DECL

3DSTATE_SO_BUFFER

The 3DSTATE_SO_BUFFER command specifies the location and characteristics of an SO buffer in memory.

3DSTATE_SO_BUFFER



Functions

Input Buffering

For the purposes of stream output, the SOL stage breaks incoming topologies into independent objects without adjacency information. In the process, any adjacent-only vertices are ignored. For example, convert TRISTRIP_ADJ into independent 3-vertex triangles. However, if rendering is enabled, incoming topologies are passed to the Clip stage unmodified and therefore the Clip unit must be enabled if there is any possibility of "ADJ" topologies reaching it.

Note that the SOL unit should not see incomplete objects: the VF will remove incomplete input objects, and the GS will remove GS-generated incomplete objects.

The OSB (Object Staging Buffer) reorders the vertices of odd-numbered triangles in TRISTRIP topologies to match API requirements.

Incoming topologies are tagged with a 2-bit StreamID. The StreamID is 0 for topologies originating from the VF stage (i.e., 3DPRIMITIVE_XXX). For topologies output from the GS stage, the StreamID is set by the GS shader. A Stream n Vertex Length is associated with each stream, and defines how much data is read from the URB for vertices in that stream.

The following table specifies how the SOL stage streams out object vertices for each incoming topology type.

PrimTopologyType	Order of Vertices Streamed Out	Any SOL Notes
<PRIMITIVE_TOPOLOGY > (N = # of vertices)	[<object#>] = (<vert#>, ...);	
POINTLIST POINTLIST_BF	[0] = (0); [1] = (1); ...; [N-2] = (N-2);	
LINELIST (N is multiple of 2)	[0] = (0,1); [1] = (2,3); ...; [(N/2)-1] = (N-2,N-1)	
LINELIST_ADJ (N is multiple of 4)	[0] = (1,2); [1] = (5,6); ...; [(N/4)-1] = (N-3,N-2)	
LINESTRIP LINESTRIP_BF LINESTRIP_CONT LINESTRIP_CONT_BF (N >= 2)	[0] = (0,1); [1] = (1,2); ...; [N-2] = (N-2,N-1)	
LINESTRIP_ADJ (N >= 4)	[0] = (1,2); [1] = (2,3); ...; [N-4] = (N-3,N-2)	



PrimTopologyType	Order of Vertices Streamed Out	Any SOL Notes
LINELOOP	N/A	Not supported after VF.
TRILIST (N is multiple of 3)	[0] = (0,1,2); [1] = (3,4,5); ...; [(N/3)-1] = (N-3,N-2,N-1)	
RECTLIST	Same as TRILIST	Handled same as TRILIST.
TRILIST_ADJ (N is multiple of 6)	[0] = (0,2,4); [1] = (6,8,10); ...; [(N/6)-1] = (N-6,N-4,N-2)	
TRISTRIP (N >= 3) REORDER_LEADING	[0] = (0,1,2); [1] = (1,3,2); [k even] = (k,k+1,k+2) [k odd] = (k,k+2,k+1) [N-3] = (see above)	"Odd" triangles have vertices reordered to yield increasing leading vertices starting with v0.
TRISTRIP (N >= 3) REORDER_TRAILING	[0] = (0,1,2); [1] = (2,1,3); [k even] = (k,k+1,k+2) [k odd] = (k+1,k,k+2) [N-3] = (see above)	"Odd" triangles have vertices reordered to yield increasing trailing vertices starting with v2.
TRISTRIP_REV (N >= 3) REORDER_LEADING	[0] = (0,2,1) [1] = (1,2,3);...; [k even] = (k,k+2,k+1) [k odd] = (k,k+1,k+2) [N-3] = (see above)	"Even" triangles have vertices reordered to yield increasing leading vertices starting with v0.
TRISTRIP_REV (N >= 3) REORDER_TRAILING	[0] = (1,0,2) [1] = (1,2,3);...; [k even] = (k+1,k,k+2) [k odd] = (k,k+1,k+2) [N-3] = (see above)	"Even" triangles have vertices reordered to yield increasing trailing vertices starting with v2.
TRISTRIP_ADJ (N even, N >= 6) REORDER_LEADING	N = 6 or 7: [0] = (0,2,4) N = 8 or 9: [0] = (0,2,4); [1] = (2,6,4); ...; N > 10: [0] = (0,2,4); [1] = (2,6,4); ...; [k>1, even] = (2k, 2k+2, 2k+4); [k>2, odd] = (2k, 2k+4, 2k+2);...; Trailing object:	"Odd" objects have vertices reordered to yield increasing-by-2 leading vertices starting with v0.



PrimTopologyType	Order of Vertices Streamed Out	Any SOL Notes
	$[(N/2)-3, \text{even}] = (N-6, N-4, N-2);$ $[(N/2)-3, \text{odd}] = (N-6, N-2, N-4);$	
TRISTRIP_ADJ (N even, $N \geq 6$) REORDER_TRAILING	N = 6 or 7: $[0] = (0, 2, 4)$ N = 8 or 9: $[0] = (0, 2, 4);$ $[1] = (4, 2, 6); \dots;$ N > 10: $[0] = (0, 2, 4);$ $[1] = (4, 2, 6); \dots;$ $[k > 1, \text{even}] = (2k, 2k+2, 2k+4);$ $[k > 2, \text{odd}] = (2k+2, 2k, 2k+4); \dots;$ Trailing object: $[(N/2)-3, \text{even}] = (N-6, N-4, N-2);$ $[(N/2)-3, \text{odd}] = (N-4, N-6, N-2);$	"Odd" objects have vertices reordered to yield increasing-by-2 trailing vertices starting with v4.
TRIFAN (N > 2)	$[0] = (0, 1, 2);$ $[1] = (0, 2, 3); \dots;$ $[N-3] = (0, N-2, N-1);$	
TRIFAN_NOSTIPPLE	Same as TRIFAN	
POLYGON	Same as TRIFAN	
QUADLIST QUADSTRIP	N/A	Not supported after VF.
PATCHLIST_1	$[0] = (0);$ $[1] = (1); \dots;$ $[N-2] = (N-2);$	
PATCHLIST_2	$[0] = (0, 1);$ $[1] = (2, 3); \dots;$ $[(N/2)-1] = (N-2, N-1)$	
PATCHLIST_3..32	similar to above	



Stream Output Function

As previously mentioned, incoming 3D topologies are targeted at one of the four streams. The SOL stage contains state information specific to each of the four streams.

A stream's list of SO declarations (SO_DECL structures) is used to perform the SO function for objects targeted to that particular stream. The 3DSTATE_SO_DECL_LIST command is used to specify the list of SO_DECL structures for all four streams in parallel. Software is required to scan the SO_DECL lists of streams to determine which SO buffers are targeted. The Stream To Buffer Selects bits in 3DSTATE_SO_DECL_LIST must be programmed accordingly (if the buffer is targeted, the select bit must be set, else it must be cleared).

If a stream has no SO_DECL state defined (NumEntries is 0), incoming objects targeting that stream are effectively ignored. As there is no attempt to perform stream output, overflow detection is neither required nor performed.

Otherwise, an overflow check is performed. First any attempt to output to a disabled buffer is detected. This occurs when the stream has a Stream To Buffer Selects bit set but the corresponding SO Buffer Enable is clear. Assuming all targeted buffers are enabled, an additional check is made to ensure that there is enough room in each targeted buffer to hold the number of vertices which be output to it (for the input object). Here the buffer's current end address is compared to what the write offset would be if the output was performed. The latter value is computed as $(write_offset + vertex_count * buffer_pitch)$. If this value is greater than the end address, an overflow is signalled. This check is performed for each buffer included in Stream To Buffer Selects.

If an overflow is not signaled, the SO function is performed. The SO_DECL list for the targeted stream is traversed independently for each object vertex, and the operation specified by the SO_DECL structure is performed (typically causing data to be appended to an SO buffer). In the process, SO buffer Write Offsets are incremented.



Stream Output Buffers

Up to four SO buffers are supported. The SO buffer parameters (start/end address, etc.) are specified by the 3DSTATE_SO_BUFFER command.

The 3DSTATE_STREAMOUT command specifies an SO Buffer Enable bit for each of the buffers. If a buffer is disabled, its state is ignored and no output will be attempted for that buffer. Any attempt to output to that buffer will immediately signal an overflow condition.

The SOL stage maintains a current Write Offset register value for each SO buffer. These registers can be written via MI_LOAD_REGISTER_MEM or MI_LOAD_REGISTER_IMM commands. The SOL stage will increment the Write Offsets as a part of the SO function. Software can cause a Write Offset register to be written to memory via an MI_STORE_REGISTER_MEM command, though a preceding flush operation may be required to ensure that any previous SO functions have completed.

Project	Surface Format Name	Security
[DevSNB+]	R32G32B32A32_FLOAT	
[DevSNB+]	R32G32B32A32_SINT	
[DevSNB+]	R32G32B32A32_UINT	
[DevSNB+]	R32G32B32_FLOAT	
[DevSNB+]	R32G32B32_SINT	
[DevSNB+]	R32G32B32_UINT	
[DevSNB+]	R32G32_FLOAT	
[DevSNB+]	R32G32_SINT	
[DevSNB+]	R32G32_UINT	
[DevSNB+]	R32_SINT	
[DevSNB+]	R32_UINT	
[DevSNB+]	R32_FLOAT	

Rendering Disable

Independent of SOL function enable, if rendering (i.e, 3D pipeline functions past the SOL stage) is enabled (via clearing the Rendering Disable bit), the SOL stage will pass topologies for a specific input stream (as selected by Render Stream Select) down the pipeline, with the exception of PATCHLIST_n topologies which are never passed downstream. Software must ensure that the vertices exiting the SOL stage include a vertex header and position value so that the topologies can be correctly processed by subsequent pipeline stages. Specifically, rendering must be disabled whenever 128-bit vertices are output from a GS thread.

If Rendering Disable is set, the SOL stage will prevent any topologies from exiting the SOL stage.



Statistics

The SOL stage controls the incrementing of two 64-bit statistics counter registers for each of the four output buffer slots, `SO_NUM_PRIMS_WRITTEN[]` and `SO_PRIM_STORAGE_NEEDED[]`.



3D Pipeline Rasterization

3D Pipeline – CLIP Stage Overview

The CLIP stage of the GEN 3D Pipeline is similar to the GS stage in that it can be used to perform general processing on incoming 3D objects via spawned GEN4 threads. However, the CLIP stage also includes specialized logic to perform a *ClipTest* function on incoming objects. These two usage models of the CLIP stage are outlined below.

Refer to the *Common 3D FF Unit Functions* subsection in the *3D Overview* chapter for a general description of a 3D Pipeline stage, as much of the CLIP stage operation and control falls under these *common* functions. I.e., many of the CLIP stage state variables and CLIP thread payload parameters are described in *3D Overview*, and although they are listed here for completeness, that chapter provides the detailed description of the associated functions.

Refer to this chapter for an overall description of the CLIP stage, details on the *ClipTest* function, and any exceptions the CLIP stage exhibits with respect to common FF unit functions.

Clip Stage – General-Purpose Processing

Numerous state variable controls are provided to tailor the *ClipTest* function as required by the API or primitive characteristics. These controls allow a mode where all objects are passed to CLIP threads, and in this regard the CLIP stage can be used as a second GS stage. However, unlike the GS stage, primitives output by CLIP threads will not be subject to 3D Clipping, and therefore any clip-testing/clipping of these primitives (if required) would need to be performed by the CLIP thread itself.

Clip Stage – 3D Clipping

The *ClipTest* fixed function is provided to optimize the CLIP stage for support of generalized *3D Clipping*. The CLIP FF unit examines the position of incoming vertices, performs a fixed function *VertexClipTest* on these positions, and then examines the results for the vertices of each independent object in *ClipDetermination*.

The results of *ClipDetermination* indicate whether an object is to be processed by a thread (*MustClip*), discarded (*TrivialReject*) or passed down the pipeline unmodified (*TrivialAccept*). In the *MustClip* case, the spawned thread is responsible for performing the actual 3D Clipping algorithm. The CLIP thread is passed the source object vertex data and is able to output a new, arbitrary 3D primitive (e.g., the clipped primitive), or no output at all. Note that the output primitive is independent in that it is comprised of newly-generated VUEs, and does not share vertices with the source primitive or other CLIP-generated primitives.

New vertices produced by the CLIP threads are stored in the URB. Their Vertex Headers are then read from the VUEs in order to insert the relevant information into the 3D pipeline. The CLIP unit maintains the proper ordering of CLIP-generated primitives and any surrounding trivially-accepted primitives. The CLIP unit also supports multiple concurrent CLIP threads and maintains the proper ordering of the thread outputs as dictated by the order of the source objects.



The outgoing primitive stream is sent down the pipeline to the Strip/Fan (SF) FF stage (now including the read-back VUE Vertex Header data such as Vertex Position (NDC or screen space), RTAIndex, VPIndex, PointWidth) and control information (PrimType, PrimStart, PrimEnd) while the remainder of the vertex data remains in the VUE in the URB.

Fixed Function Clipper

The GPU supports Fixed Function Clipping.

Note: In an earlier generation, clipping was done in the EU. However the clipper thread latency was high and caused a bottleneck in the pipeline. Hence the motivation for a fixed function clipper.

Concepts

This section provides an overview of 3D clip-testing and clipping concepts, as defined by OpenGL APIs. It is provided as background material. Some of the concepts impact HW functionality while others impact CLIP kernel functionality.

The Clip Volume

3D objects are optionally clipped to the *clip volume*. The clip volume is defined as the intersection of a set of *clip half-spaces*. Six of these half-spaces define the view volume, while additional, user-defined half-spaces can be employed to perform clipping (or at least culling) within the view volume.

The CLIP stage design will permit the enable/disable of certain subsets of these clip half-spaces. This capability can be used, for example, to disable viewport, guardband, and near and far clipping as required by the API and other conditions.

View Volume

The intersection of the six view half-spaces defines the *view volume*. The view volume is defined in 4D clip space coordinates as:

View Clip Plane	Outside Condition	
	4D Clip Space	NDC space, positive w
XMIN (NDC Left)	$\text{clip.x} < -\text{clip.w}$	$\text{ndc.x} < -1$
XMAX (NDC Right)	$\text{clip.w} < \text{clip.x}$	$\text{ndc.x} > 1$
YMIN (NDC Bottom)	$\text{clip.y} < -\text{clip.w}$	$\text{ndc.y} < -1$
YMAX (NDC top)	$\text{clip.w} < \text{clip.y}$	$\text{ndc.y} > 1$
ZMIN (NDC Near)	OGL: $\text{clip.z} < -\text{clip.w}$	OGL: $\text{ndc.z} < -1.0$



View Clip Plane	Outside Condition	
	4D Clip Space	NDC space, positive w
ZMAX (NDC Far)	$\text{clip.w} < \text{clip.z}$	$\text{ndc.z} > 1.0$

Note that, since the 2D (X,Y) extent of the projected view volume is subsequently mapped to the 2D pixel space viewport, the terms *viewport* and *view volume* are used somewhat interchangeably in this discussion.

The CLIP unit will perform view volume clip test using NDC coordinates (the results of the speculative PerspectiveDivide). The treatment of negative ndc.w and invalid (NaN, +/-INF) coordinates is clarified below.

Negative W Coordinates

Consider for a moment vertices with a negative clip.w coordinate. Examination of the API definitions for *outside* shows that it is impossible for that vertex to be considered inside both the XMIN (NDC Left) and XMAX (NDC Right) planes. The clip.x coordinate would need to be greater than or equal to some positive value ($-\text{clip.w}$) to be considered inside the XMIN plane, while also being less than or equal to the negative (clip.w) value to be considered inside the XMAX plane. Obviously both these conditions cannot be met simultaneously, so a vertex with a negative clip.w coordinate will always appear outside.

Surprisingly, it is possible for a vertex to be outside both the XMIN and XMAX planes (and likewise for the Y axis). This arises when clip.w is negative and clip.x falls between clip.w and $-\text{clip.w}$. Note, however, that in NDC space (post perspective-divide), this same vertex would be considered inside. This disparity arises from the loss of information from the perspective divide operation, specifically the signs of the input operands. The CLIP stage will avoid this artifact by supporting an additional $\text{clip.w}=0$ clip plane – a negative ndc.rhw value indicates the point is outside of the $\text{clip.w}=0$ plane.

The assumption made in the Clip stage is that only the $w>0$ portion of clip space is considered visible. The `VertexClipTest` function tests each incoming $1/w$ value and, if negative, the vertex is tagged as being outside the $w=0$ plane. These vertex outcodes are combined in `ClipDetermination` to determine TA/TR/MC status.

A negative w coordinate poses an additional issue due to the fact that `VertexClipTest` is performed using post-perspective-projection coordinates (NDC or screen space). This disparity arises from the loss of information from the perspective divide operation, specifically the signs of the input operands. For example, to test for $(x>w)$ using NDC coordinates, $(x/w>1)$ must be used when $w>0$, and $(x/w<1)$ must be used when $w<0$. The `VertexClipTest` function therefore uses the sign of the incoming $1/w$ coordinate to select the appropriate comparison function for each of the VP and GB clip planes.

As the CLIP thread performs clipping in 4D clip space, only the truly visible portions of objects (i.e., meeting the 4D clip space visibility criteria) will be considered. The CLIP thread should not output negative w (clip or NDC) coordinates.

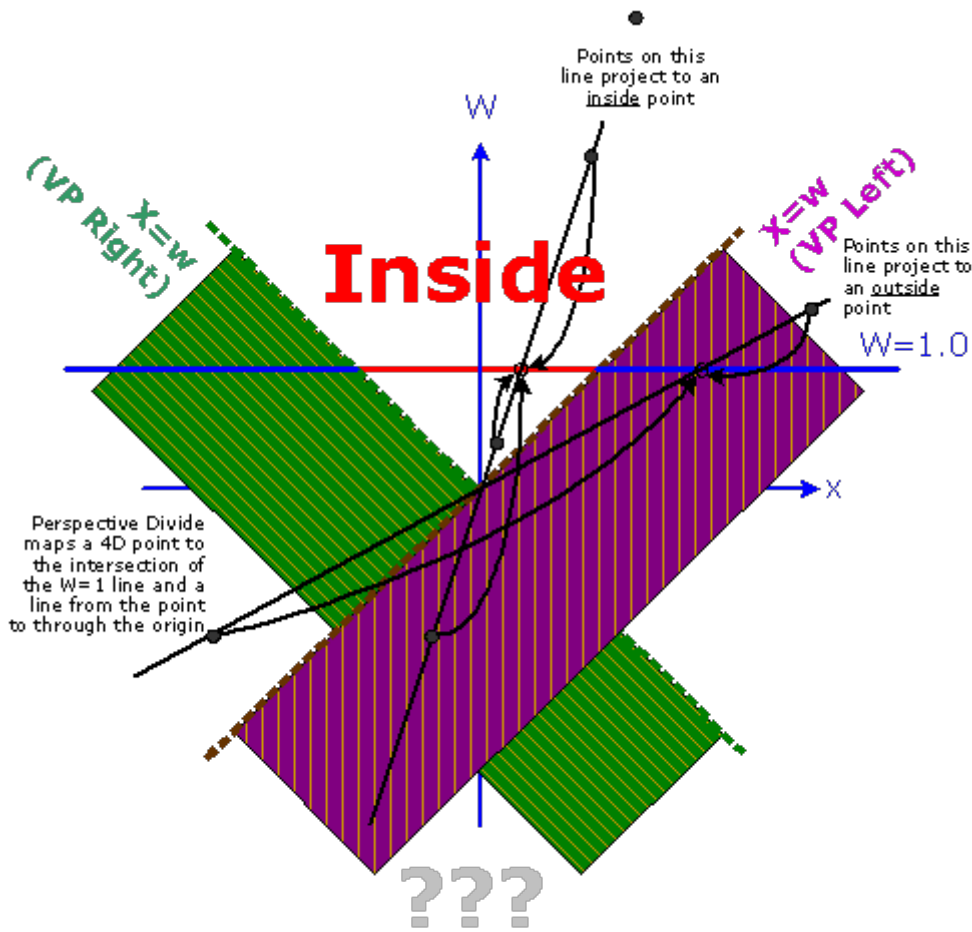

B6841-01

User-Specified Clipping

The various APIs define mechanisms by which objects can be clipped or culled according to some user-specified parameter(s) in addition to the implied viewport clipping. In GEN, the HW support of these mechanisms is restricted to use of the 8 UserClipFlags (UCFs) of the VUE Vertex Header. Software is required to provide the remaining support (e.g., the JITTER including GEN4 instructions to cause a distance value to be computed, tested for visibility, and generation of the appropriate UCF bit.)

Guard Band

Note: Refer to Vertex X,Y Clamping and Quantization in the SF stage section for device-specific guardband size information.

3D Clipping is time consuming. For cases where 2D Clipping is sufficient, we are willing to forgo 3D Clipping and instead apply 2D Clipping during rendering. In the general case, this is possible only when an object is totally within the ZMin and ZMax planes, and only clipping to the view volume X/Y MIN/MAX clip planes is required, as 2D Clipping is restricted to a screen-aligned 2D rectangle.

However, we must ensure that the 2D extent of these objects does not exceed the limitations of the renderer's coordinate space (see Vertex X,Y Clamping and Quantization in the SF section). Therefore we define a 2D *guardband* region corresponding to (though likely somewhat smaller than) the maximum 2D extent supported by the renderer. During VertexClipTest, vertices are (optionally) subjected to an additional visibility test based on the 2D guardband region.

During ClipDetermination, if an object is not trivially-rejected from the 2D viewport, the XMIN_GB, XMAX_GB, YMIN_GB and YMAX_GB guardband outcodes are used instead of the XMIN, XMAX, YMIN, YMAX view volume outcodes to determine trivial-accept. This allows objects that fall within the guardband and possibly intersect the viewport to be trivially-accepted and passed down the pipeline.

The diagram below shows some examples of objects (triangles) in relation to the viewport and guardband. The shaded triangles are examples of triangles that are not trivially accepted to the viewport but trivially accepted to the guardband and therefore passed down the pipeline. Without the guardband, these triangles would have to be submitted to a CLIP thread.

Normal Guardband Operation

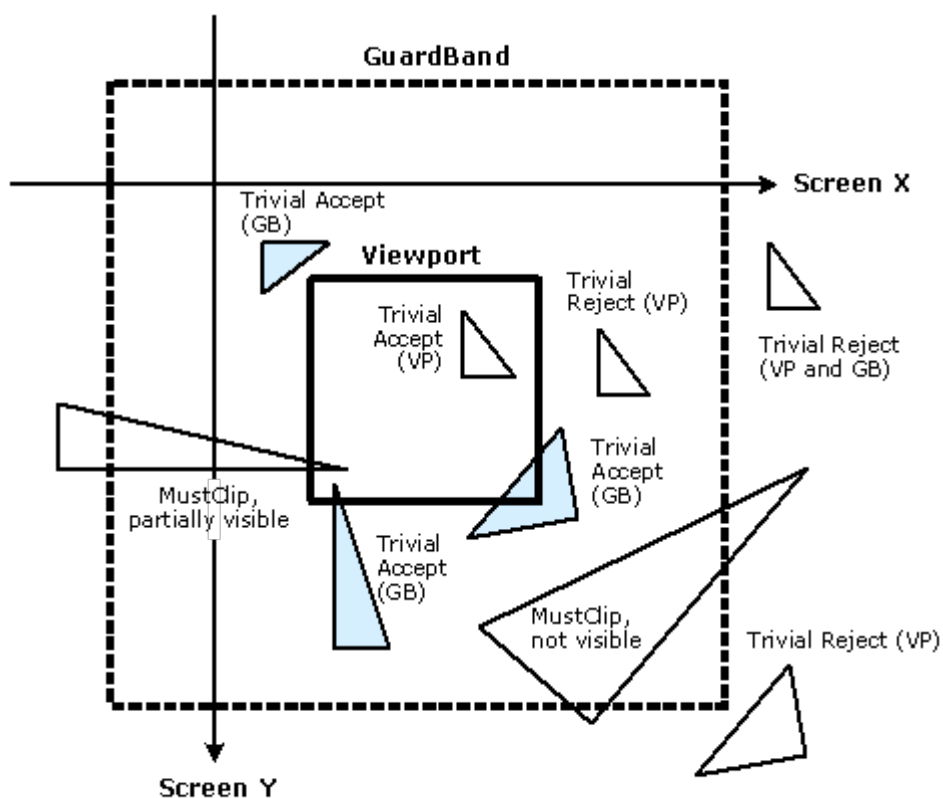

B 6822-01

The CLIP stage needs to handle the case where the viewport XY is larger than the screen space coordinate range supported by the SF and WM units. This condition may arise when the API defines an implicit 2D clip between the viewport XY extent and the render target. In the GEN4 3D pipeline, the guardband must be used to force explicit clipping in order to ensure legal coordinates are passed out of the CLIP stage. Therefore the CLIP unit supports a guardband that can be larger or smaller than the viewport (in any particular direction). The following diagram illustrates a case with a very large viewport,



extending well beyond the guardband. Note that the only trivial accept case is where objects are completely within the guardband.

Very Large Viewport Case

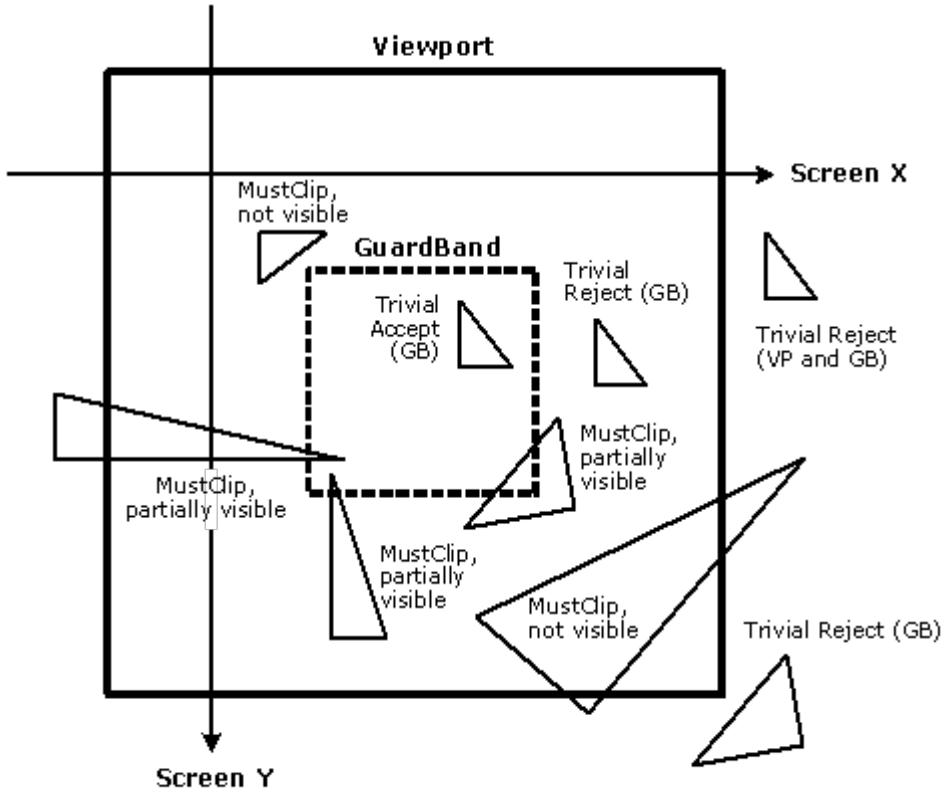

B.6842-01

NDC Guardband Parameters

Note: Refer to *Vertex X,Y Clamping and Quantization in the SF stage section for device-specific guardband size information.*

When the CLIP unit performs VertexClipTest in NDC space, the guardband limits must be provided as NDC coordinates. The diagram below shows how the guardband NDC coordinates are derived. Specifically, the XMIN_GB NDC coordinate is simply the ratio of the (screen space) distance from the screen space VP center to the screen space GB XMin boundary over the distance from the VP center to the VP XMin (left) boundary. A similar computation yields the XMAX_GB (right), YMIN_GB (bottom) and YMAX_GB (top) guardband NDC coordinates.

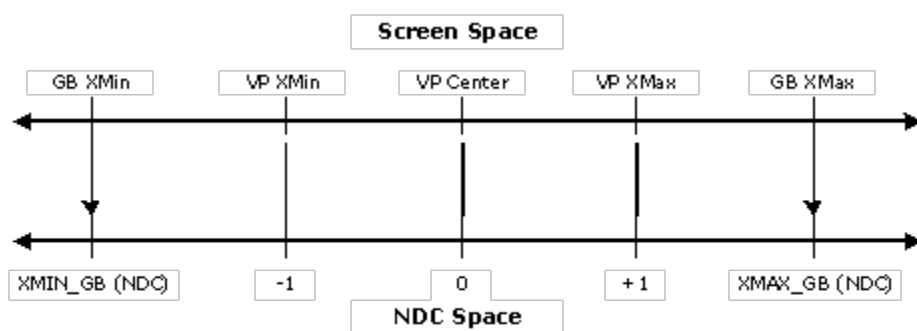

B6843-01

As these guardband parameters are defined relative to the viewport, each of the up-to-16 sets of viewport specifications supported in the 3D pipeline will require a corresponding set of guardband parameters. These guardband parameters are provided as a separate memory-resident state structure (CLIP_VIEWPORT), and referenced via the **Clipper Viewport State Pointer** contained in the CLIP_STATE structure. Note that the CLIP_VIEWPORT structure has a different definition than the SF_VIEWPORT structure used by the SF unit.

Vertex-Based Clip Testing Considerations

The CLIP unit performs clip test and determines whether objects need to be clipped based solely on information (position, UserClipFlags) provided at the vertices of the object as they arrive at the clip stage. Issues arise if and when the corresponding rendered object is not constrained to the convex hull of the object. Different APIs impose different treatment of these conditions.

In addition and in the more general case, a CLIP thread could be used to convert the object (as defined by its vertices) into some arbitrary output primitive. In this case, the CLIP unit's ClipTest/ClipDetermination logic may not be suitable for determination of when to reject/accept/clip objects. In this case the ClipMode can be used to route all (or all non-rejected) objects to CLIP threads, where the proper clip-test and clipping can occur in the CLIP kernel.

One issue that arises is whether a trivial-reject to the VPXY is suitable. If this were allowed, an object might be discarded even if it would have been partially visible in the viewport. A second issue is whether a TA against the GB is suitable. If this were allowed, portions of the rendered object might be visible in the VP even if the object should have been clipped out of the VP.

Triangle Objects

In the normal processing of triangle-based primitives (tristrip/trilist/polygon/etc.), the footprint of each triangle is constrained to the 2D convex hull. I.e., the rendering of these triangles will not produce pixels outside of the triangle. Therefore the normal operation of the CLIP unit functions will support the proper clip testing and clip determination for triangle objects:

- Both the VPXY and GB clip boundaries can be utilized (as described above). If the triangle is TR against the VP, it can be discarded. Otherwise, if the triangle is TA against the GB, it can be passed down the pipeline (assuming it is TA against VPZ, UCFs, etc.) and properly handled by 2DClipping.



- The GB parameters can be programmed to coincide with the maximum allowable screen space extent (though making the GB marginally smaller than this max extent is highly recommended).

Non-Wide Line Objects

In the normal processing of non-wide, line-based primitives (linestrip/linelist/etc.), the footprint of each line is constrained to the 2D convex hull. I.e., the rendering of these lines will not produce pixels off of the line. Therefore the normal operation of the CLIP unit functions will support the proper clip testing and clip determination for non-wide line objects. (See Triangle Objects above).

Wide Line Objects

The GEN rendering hardware supports wide lines (solid lines with a line width or anti-aliased lines). When rendered, pixels outside of the convex hull will be generated.

The following diagram shows an example of a wide line that normally would be TA against the GB. If the TA is allowed, the partially-visible region of the line would be rendered.

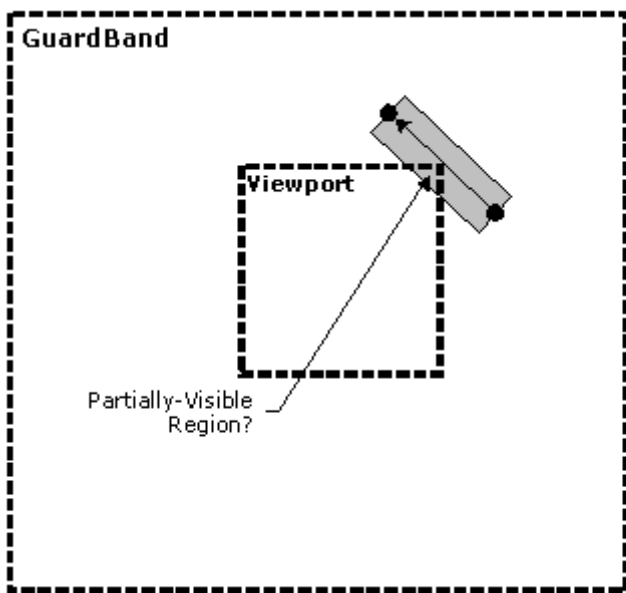

B6844-01

In general, OpenGL dictates that the partially-visible region must not be rendered. In this case the line must be clipped-out against the VPXY (not TA against the GB). To accomplish this, SW could disable the GB when drawing wide lines.

Wide Points

The GEN rendering hardware supports a width parameter for native line objects. When rendered, pixels surrounding the point (center) vertex will be generated.

The following diagram shows an example wide point that normally would be TR against the VPXY. If the TR is allowed, the partially-visible region of the point would not be rendered.

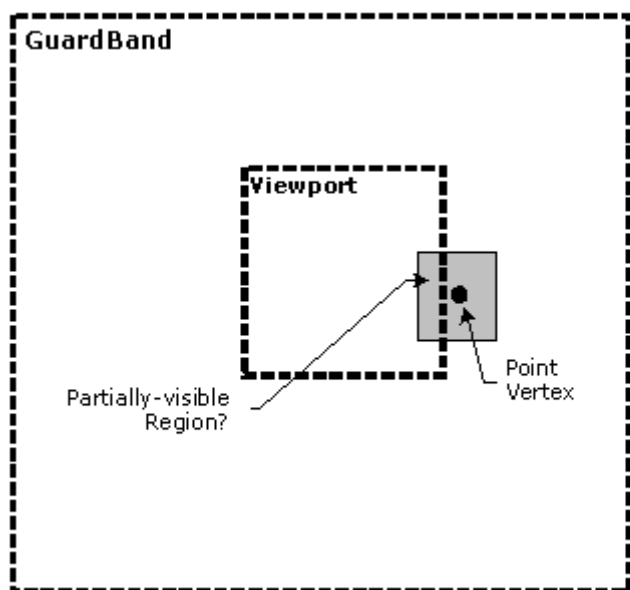

B6845-01

In general, OpenGL dictates that the partially-visible region must not be rendered. In this case the point must be TR against the VPXY (not TA against the GB). To accomplish this, SW could disable the GB when drawing wide points.

RECTLIST

The CLIP unit treats RECTLIST exactly like TRILIST. No special consideration is made for the implied 4th vertex of each rectangle (although ViewportXY and Guardband VertexClipTest theoretically should be sufficient to drive ClipDetermination). Given this, and the fact that RECTLIST is primarily intended for driver-generated *BLT* functions, there are number of restrictions on the use of RECTLIST, especially regarding the CLIP unit. Refer to the RECTLIST definition in 3D Pipeline.

3D Clipping

If an object needs to be clipped, it is passed to the CLIP thread. The CLIP thread performs some (arbitrary) algorithm to clip the primitive, and subsequently output *new* vertices as a primitive defining the visible region of the input object (assuming there is a visible region). In the process of spawning the CLIP thread, the input vertices may be considered *consumed* and therefore dereferenced. Therefore the CLIP thread needs to copy (if required) any input VUE data to a new output VUE; there is no mechanism to *output* input vertices other than copying.

[DevSNB+] supports only Fixed function Clipping.

CLIP Stage Input

As a stage of the GEN 3D pipeline, the CLIP stage receives inputs from the previous (GS) stage. Refer to *3D Overview* for an overview of the various types of input to a 3D Pipeline stage. The remainder of this subsection describes the inputs specific to the CLIP stage.



State

This section contains state clips for the Clip Stage. For each processor generation, the state used by the clip stage is defined by the appropriate inline state packet, linked below.

3DSTATE_CLIP

VUE Readback

Starting with the CLIP stage, the 3D pipeline requires vertex information in addition to the VUE handle. For example, the CLIP unit's VertexClipTest function needs the vertex position, as does the SF unit's functions. This information is obtained by the 3D pipeline reading a portion of each vertex's VUE data directly from the URB. This readback (effectively) occurs immediately before the CLIP VertexClipTest function, and immediately after a CLIP thread completes the output of a destination VUE.

The Vertex Header (first 256 bits) of the VUE data is read back. (See the previous *VUE Formats* subsection (above) for details on the content and format of the Vertex Header.) Additional Clip/Cull data (located immediately past the Vertex Header) may be read prior to clipping.

This readback occurs automatically and is not under software control. The only software implication is that the Vertex Header must be valid at the readback points, and therefore must have been previously loaded or written by a thread.

VertexClipTest Function

The VertexClipTest function compares each incoming vertex position (x,y,z,w) with various viewport and guardband parameters (either hard-coded values or specified by state variables).

The RHW component of the incoming vertex position is tested for NaN value, and if a NaN is detected, the vertex is marked as "BAD" by setting the outcode[BAD]. If a NaN is detected in any vertex homogeneous x,y,z,w component or an enabled ClipDistance value, the vertex is marked as "BAD" by setting the outcode[BAD].

In general, any object containing a BAD vertex will be discarded, as how to clip/render such objects is undefined.

However, in the case of CLIP_ALL mode, a CLIP thread will be spawned even for objects with "BAD" vertices. The CLIP kernel is required to handle this case, and can examine the **Object Outcode [BAD]** payload bit to detect the condition. (Note that the VP and GB Object Outcodes are UNDEFINED when BAD is set.)

If the incoming RHW coordinate is negative (including negative 0) the NEGW outcode is set. Also, this condition is used to select the proper comparison functions for the VP and GB outcode tests (below).

Next, the VPXY and GB outcodes are computed, depending on the corresponding enable SV bits. If one of VPXY or GB is disabled, the enabled set of outcodes are copied to the disabled set of outcodes. This effectively defines the disabled boundaries to coincide with the enabled boundaries (i.e., disabling the GB is just like setting it to the VPXY values, and vice versa).



The VPZ outcode is computed as required by the API mode SV.

Finally, the incoming UserClipFlags are masked and copied to corresponding outcodes.

The following algorithm is used by VertexClipTest:

```
//  
// Vertex ClipTest  
//  
// On input:  
// if (CLIP.PreMapped)  
//   x,y are viewport mapped  
//   z is NDC ([0,1] is visible)  
// else  
//   x,y,z are NDC (post-perspective divide)  
// w is always 1/w  
//  
// Initialize outCodes to "inside"  
//  
outCode[*] = 0  
//  
// Check if w is NaN  
// Any object containing one of these "bad" vertices will likely be  
discarded  
//  
if (ISNAN(homogeneous x,y,z,w or enabled ClipDistance value)  
{  
  outCode[BAD] = 1  
}  
//  
// If 1/w is negative, w is negative and therefore outside of the w=0 plane  
//  
//  
rhw_neg = ISNEG(rhw)  
if (rhw_neg)  
{  
  outCode[NEGW] = 1
```



```
}  
//  
// View Volume Clip Test  
// If Premapped, the 2D viewport is defined in screen space  
// otherwise the canonical NDC viewvolume applies ([-1,1])  
//  
if (CLIP_STATE.Premapped)  
{  
    vp_XMIN = CLIP_STATE.VP_XMIN  
    vp_XMAX = CLIP_STATE.VP_XMAX  
    vp_YMIN = CLIP_STATE.VP_YMIN  
    vp_YMAX = CLIP_STATE.VP_YMAX  
}  
} else {  
    vp_XMIN = -1.0f  
    vp_XMAX = +1.0f  
    vp_YMIN = -1.0f  
    vp_YMAX = +1.0f  
}  
  
if (CLIP_STATE.ViewportXYClipTestEnable) {  
outCode[VP_XMIN] = (x < vp_XMIN)  
outCode[VP_XMAX] = (x > vp_XMAX)  
outCode[VP_YMIN] = (y < vp_YMIN)  
outCode[VP_YMAX] = (y > vp_YMAX)  
    #ifdef (DevBW-E0)  
        if (rhw_neg) {  
outCode[VP_XMIN] = (x >= vp_XMIN)  
outCode[VP_XMAX] = (x <= vp_XMAX)  
outCode[VP_YMIN] = (y >= vp_XMIN)  
outCode[VP_YMAX] = (y <= vp_XMAX)  
        }  
    #endif  
        if (rhw_neg) {  
outCode[VP_XMIN] = (x > vp_XMIN)  
outCode[VP_XMAX] = (x < vp_XMAX)
```



```
    outCode[VP_YMIN] = (y > vp_XMIN)
    outCode[VP_YMAX] = (y < vp_XMAX)
}
}
if (CLIP_STATE.ViewportZClipTestEnable) {
    if (CLIP_STATE.APIMode == APIMODE_D3D) {
vp_ZMIN = 0.0f
vp_ZMAX = 1.0f
    } else { // OGL
vp_ZMIN = -1.0f
vp_ZMAX = 1.0f
    }
    outCode[VP_ZMIN] = (z < vp_ZMIN)
    outCode[VP_ZMAX] = (z > vp_ZMAX)
#ifdef (DevBW-E0)
    if (rhw_neg) {
outCode[VP_ZMIN] = (z >= vp_ZMIN)
    outCode[VP_ZMAX] = (z <= vp_ZMAX)
}
#endif
    if (rhw_neg) {
outCode[VP_ZMIN] = (z > vp_ZMIN)
    outCode[VP_ZMAX] = (z < vp_ZMAX)
}
}
//
// Guardband Clip Test
//
if {CLIP_STATE.GuardbandClipTestEnable} {
    gb_XMIN = CLIP_STATE.Viewport[vpindex].GB_XMIN
    gb_XMAX = CLIP_STATE.Viewport[vpindex].GB_XMAX
    gb_YMIN = CLIP_STATE.Viewport[vpindex].GB_YMIN
    gb_YMAX = CLIP_STATE.Viewport[vpindex].GB_YMAX
    outCode[GB_XMIN] = (x < gb_XMIN)
```



```
    outCode[GB_XMAX] = (x > gb_XMAX)
    outCode[GB_YMIN] = (y < gb_YMIN)
    outCode[GB_YMAX] = (y > gb_YMAX)
#ifdef (DevBW-E0)
    if (rhw_neg) {
outCode[GB_XMIN] = (x >= gb_XMIN)
    outCode[GB_XMAX] = (x <= gb_XMAX)
    outCode[GB_YMIN] = (y >= gb_YMIN)
    outCode[GB_YMAX] = (y <= gb_YMAX)
}
    #endif
    if (rhw_neg) {
outCode[GB_XMIN] = (x > gb_XMIN)
    outCode[GB_XMAX] = (x < gb_XMAX)
    outCode[GB_YMIN] = (y > gb_YMIN)
    outCode[GB_YMAX] = (y < gb_YMAX)
}
}
//
// Handle case where either VP or GB disabled (but not both)
// In this case, the disabled set take on the outcodes of the enabled set
//
if (CLIP_STATE.ViewportXYClipTestEnable &&
!CLIP_STATE.GuardbandClipTestEnable) {
    outCode[GB_XMIN] = outCode[VP_XMIN]
    outCode[GB_XMAX] = outCode[VP_XMAX]
    outCode[GB_YMIN] = outCode[VP_YMIN]
    outCode[GB_YMAX] = outCode[VP_YMAX]
} else if (!CLIP_STATE.ViewportXYClipTestEnable
&&
    CLIP_STATE.GuardbandClipTestEnable) {
    outCode[VP_XMIN] = outCode[GB_XMIN]
    outCode[VP_XMAX] = outCode[GB_XMAX]
    outCode[VP_YMIN] = outCode[GB_YMIN]
    outCode[VP_YMAX] = outCode[GB_YMAX]
}
```



```
//  
// X/Y/Z NaN Handling  
//  
xyorgben = (CLIP_STATE.ViewportXYClipTestEnable ||  
CLIP_STATE.GuardbandClipTestEnable)  
if (isNAN(x)) {  
    outCode[GB_XMIN] = xyorgben  
    outCode[GB_XMAX] = xyorgben  
  
    outCode[VP_XMIN] = xyorgben  
    outCode[VP_XMAX] = xyorgben  
}  
if (isNAN(y)) {  
    outCode[GB_YMIN] = xyorgben  
    outCode[GB_YMAX] = xyorgben  
  
    outCode[VP_YMIN] = xyorgben  
    outCode[VP_YMAX] = xyorgben  
}  
if (isNaN) {  
outCode[VP_ZMIN] = CLIP_STATE.ViewportZClipTestEnable  
outCode[VP_ZMAX] = CLIP_STATE.ViewportZClipTestEnable  
}  
//  
// UserClipFlags  
//  
ExamineUCFs  
for (i=0; i<7; i++)  
{  
    outCode[UC0+i] = userClipFlag[i] &  
CLIP_STATE.UserClipFlagsClipTestEnableBitmask[i]  
}  
    outCode[UC7] = userClipFlag[i] &  
CLIP_STATE.UserClipFlagsClipTestEnableBitmask[7]
```

Object Staging

The CLIP unit's Object Staging Buffer (OSB) accepts streams of input vertex information packets, along with each vertex's VertexClipTest result (outCode). This information is buffered until a complete object or



the last vertex of the primitive topology is received. The OSB then performs the ClipDetermination function on the object vertices, and takes the actions required by the results of that function.

Partial Object Removal

The OSB is responsible for removing incomplete LINESTRIP and TRISTRIP objects that it may receive from the preceding stage (GS). Partial object removal is not supported for other primitive types due to either (a) the GS is not permitted to output those primitive types (e.g., primitives with adjacency info), and the VF unit will have removed the partial objects as part of 3DPRIMITIVE processing, or (b) although the GS thread is allowed to output the primitive type (e.g., LINELIST), it is assumed that the GS kernel will be correctly implemented to avoid outputting partial objects (or pipeline behavior is UNDEFINED).

An object is considered 'partial' if the last vertex of the primitive topology is encountered (i.e., PrimEnd is set) before a complete set of vertices for that object have been received. Given that only LINESTRIP and TRISTRIP primitive types are subject to CLIP unit partial object removal, the only supported cases of partial objects are 1-vertex LINESTRIPs and 1 or 2-vertex TRISTRIPs.

ClipDetermination Function

In ClipDetermination, the vertex outcodes of the primitive are combined in order to determine the clip status of the object (TR: trivially reject; TA: trivial accept; MC: must clip; BAD: invalid coordinate). Only those vertices included in the object are examined (3 vertices for a triangle, 2 for a line, and 1 for a point). The outcode bit arrays for the vertices are separately ANDed (intersection) and ORed (union) together (across vertices, not within the array) to yield objANDCode and objORCode bit arrays.

TR/TA against interesting boundary subsets are then computed. The TR status is computed as the logical OR of the appropriate objANDCode bits, as the vertices need only be outside of one common boundary to be trivially rejected. The TA status is computed as the logical NOR of the appropriate objORCode bits, as any vertex being outside of any of the boundaries prevents the object from being trivially accepted.

If any vertex contains a BAD coordinate, the object is considered BAD and any computed TR/TA results will effectively be ignored in the final action determination.

Next, the boundary subset TR/TA results are combined to determine an overall status of the object. If the object is TR against any viewport or enabled UC plane, the object is considered TR. Note that, by definition, being TR against a VPXY boundary implies that the vertices will be TR against the corresponding GB boundary, so computing TR_GB is unnecessary.

The treatment of the UCF outcodes is conditional on the UserClipFlags MustClip Enable state. If DISABLED, an object that is not TR against the UCFs is considered TA against them. Put another way, objects will only be culled (not clipped) with respect to the UCFs. If ENABLED, the UCF outcodes are treated like the other outcodes, in that they are used to determine TR, TA or MC status, and an object can be passed to a CLIP thread simply based on it straddling a UCF.

Finally, the object is considered MC if it is neither TR or TA.

The following logic is used to compute the final TR, TA, and MC status.

```
//
```



```
// ClipDetermination
//
//
// Compute objANDCode and objORCode
//
switch (object type) {
case POINT:
{
objANDCode[...] = v0.outCode[...]
objORCode[...] = v0.outCode[...]
} break
case LINE:
{
objANDCode[...] = v0.outCode[...] & v1.outCode[...]
objORCode[...] = v0.outCode[...] | v1.outCode[...]
} break
case TRIANGLE:
{
    objANDCode[...] = v0.outCode[...] & v1.outCode[...] & v2.outCode[...]
objORCode[...] = v0.outCode[...] | v1.outCode[...] | v2.outCode[...]
} break
//
// Determine TR/TA against interesting boundary subsets
//
TR_VPXY = (objANDCode[VP_L] | objANDCode[VP_R] | objANDCode[VP_T] |
objANDCode[VP_B])
TR_GB = (objANDCode[GB_L] | objANDCode[GB_R] | objANDCode[GB_T] |
objANDCode[GB_B])
TA_GB = !(objORCode[GB_L] | objORCode[GB_R] | objORCode[GB_T] |
objORCode[GB_B])
TA_VPZ = !(objORCode[VP_N] | objORCode[VP_Z])
TR_VPZ = (objANDCode[VP_N] | objANDCode[VP_Z])
TA_UC = !(objORCode[UC0] | objORCode[UC1] | ... | objORCode[UC7])
TR_UC = (objANDCode[UC0] | objANDCode[UC1] | ... | objANDCode[UC7])
BAD = objORCode[BAD]
```



```
TA_NEGW = !objORCode[NEGW]
TR_NEGW = objANDCode[NEGW]
//
// Trivial Reject
//
// An object is considered TR if all vertices are TR against any common
boundary
// Note that this allows the case of the VPXY being outside the GB
//
TR = TR_GB || TR_VPXY || TR_VPZ || TR_UC || TR_NEGW
#else
TR = TR_GB || TR_VPXY || TR_VPZ || TR_UC
//
// Trivial Accept
//
// For an object to be TA, it must be TA against the VPZ and GB, not TR,
// and considered TA against the UC planes and NEGW
// If the UCMC mode is disabled, an object is considered TA against the UC
// as long as it isn't TR against the UC.
// If the UCMC mode is enabled, then the object really has to be TA against
the UC
// to be considered TA
// In this way, enabling the UCMC mode will force clipping if the object is
neither
// TA or TR against the UC
//
TA = !TR && TA_GB && TA_VPZ && TA_NEGW
UCMC = CLIP_STATE.UserClipFlagsMustClipEnable
TA = TA && ( (UCMC && TA_UC) || (!UCMC && !TR_UC) )
//
// MustClip
// This is simply defined as not TA or TR
// Note that exactly one of TA, TR and MC will be set
//
MC = !(TA || TR)
```



ClipMode

The ClipMode state determines what action the CLIP unit takes given the results of ClipDetermination. The possible actions are:

- PASSTHRU: Pass the object directly down the pipeline. A CLIP thread is not spawned.
- DISCARD: Remove the object from the pipeline and dereference object vertices as required (i.e., dereferencing will not occur if the vertices are shared with other objects).
- SPAWN: Pass the object to a CLIP thread. In the process of initiating the thread, the object vertices may be dereferenced.

The following logic is used to determine what to do with the object (PASSTHRU or DISCARD or SPAWN).

```
//  
// Use the ClipMode to determine the action to take  
//  
switch (CLIP_STATE.ClipMode) {  
  case NORMAL: {  
    PASSTHRU = TA && !BAD  
    DISCARD = TR || BAD  
    SPAWN    = MC && !BAD  
  }  
  case CLIP_ALL: {  
    PASSTHRU = 0  
    DISCARD = 0  
    SPAWN    = 1  
  }  
  case CLIP_NOT_REJECT: {  
    PASSTHRU = 0  
    DISCARD = TR || BAD  
    SPAWN    = !(TR || BAD)  
  }  
  case REJECT_ALL: {  
    PASSTHRU = 0  
    DISCARD = 1  
    SPAWN    = 0  
  }  
  case ACCEPT_ALL: {
```



```
PASSTHRU = !BAD
DISCARD = BAD
SPAWN = 0
}
} endswitch
```

NORMAL ClipMode

In NORMAL mode, objects will be discarded if TR or BAD, passed through if TA, and passed to a CLIP thread if MC. This mode is typically used when the CLIP kernel is only used to perform 3D Clipping (the expected usage model).

CLIP_ALL ClipMode

In CLIP_ALL mode, all objects (regardless of classification) will be passed to CLIP threads. Note that this includes BAD objects. This mode can be used to perform arbitrary processing in the CLIP thread, or as a backup if for some reason the CLIP unit fixed functions (VertexClipTest, ClipDetermination) are not sufficient for controlling 3D Clipping.

CLIP_NON_REJECT ClipMode

This mode is similar to CLIP_ALL mode, but TR and BAD objects are discarded and all other (TA, MC) objects are passed to CLIP threads. Usage of this mode assumes that the CLIP unit fixed functions (VertexClipTest, ClipDetermination) are sufficient at least in respect to determining trivial reject.

REJECT_ALL ClipMode

In REJECT_ALL mode, all objects (regardless of classification) are discarded. This mode effectively clips out all objects.

ACCEPT_ALL ClipMode

In ACCEPT_ALL mode, all non-BAD objects are passed directly down the pipeline. This mode partially disables the CLIP stage. BAD objects will still be discarded, and incomplete primitives (generated by a GS thread) will be discarded.

Primitive topologies with adjacency are also handled, in that the adjacent-only vertices are dereferenced and only non-adjacent objects are passed down the pipeline. This condition can arise when primitive topologies with adjacency are generated but the GS stage is disabled. If this condition is allowed, the CLIP stage must not be completely disabled – as this would allow adjacent vertices to pass through the CLIP stage and lead to *unpredictable* results as the rest of the pipeline does not comprehend adjacency.



Object Pass-Through

Depending on ClipMode, objects may be passed directly down the pipeline. The PrimTopologyType associated with the output objects may differ from the input PrimTopologyType, as shown in the table below.

Programming Note: The CLIP unit does *not* tolerate primitives with adjacency that have *dangling vertices*. This should not be an issue under normal conditions, as the VF unit does not generate these sorts of primitives and the GS thread is restricted (though by specification only) to not output these sorts of primitives.

Input PrimTopologyType	Pass-Through Output PrimTopologyType	Notes
POINTLIST	POINTLIST	
POINTLIST_BF	POINTLIST_BF	
LINELIST	LINELIST	
LINELIST_ADJ	LINELIST	Adjacent vertices removed.
LINESTRIP	LINESTRIP	
LINESTRIP_ADJ	LINESTRIP	Adjacent vertices removed.
LINESTRIP_BF	LINESTRIP_BF	
LINESTRIP_CONT	LINESTRIP_CONT	
LINESTRIP_CONT_BF	LINESTRIP_CONT_BF	
LINELOOP	N/A	Not supported after GS.
TRILIST	TRILIST	
RECTLIST	RECTLIST	
TRILIST_ADJ	TRILIST	Adjacent vertices removed.
TRISTRIP	TRISTRIP or TRISTRIP_REV	Depends on where the incoming strip is broken (if at all) by discarded or clipped objects See Tristrip Clipping Notes subsection.
TRISTRIP_REV	TRISTRIP or TRISTRIP_REV	Depends on where the incoming strip is broken (if at all) by discarded or clipped objects. See Tristrip Clipping Notes subsection.
TRISTRIP_ADJ	TRISTRIP or TRISTRIP_REV	Depends on where the incoming strip is broken (if at all) by discarded or clipped objects. Adjacent vertices removed. See Tristrip Clipping Notes subsection.
TRIFAN	TRIFAN	
TRIFAN_NOSTIPPLE	TRIFAN_NOSTIPPLE	
POLYGON	POLYGON	
QUADLIST	N/A	Not supported after GS.
QUADSTRIP	N/A	Not supported after GS.



Primitive Output

(This section refers to output from the CLIP unit to the pipeline, not output from the CLIP thread)

The CLIP unit will output primitives (either passed-through or generated by a CLIP thread) in the proper order. This includes the buffering of a concurrent CLIP thread's output until the preceding CLIP thread terminates. Note that the requirement to buffer subsequent CLIP thread output until the preceding CLIP thread terminates has ramifications on determining the number of VUEs allocated to the CLIP unit and the number of concurrent CLIP threads allowed.

Other Functionality

Statistics Gathering

The CLIP unit includes logic to assist in the gathering of certain pipeline statistics . The statistics take the form of MI counter registers (see Memory Interface Registers), where the CLIP unit provides signals causing those counters to increment.

Software is responsible for controlling (enabling) these counters in order to provide the required statistics at the DDI level. For example, software might need to disable statistics gathering before submitting non-API-visible objects (e.g., RECTLISTs) for processing.

The CLIP unit must be ENABLED (via the CLIP Enable bit of PIPELINED_STATE_POINTERS) for it to affect the statistics counters. This might lead to a pathological case where the CLIP unit needs to be ENABLED simply to provide statistics gathering. If no clipping functionality is desired, Clip Mode can be set to ACCEPT_ALL to effectively inhibit clipping while leaving the CLIP stage ENABLED.

The statistic the CLIP unit affects (if enabled) is CL_INVOCATION_COUNT, incremented for every object received from the GS stage.

CL_INVOCATION_COUNT

If the **Statistics Enable** bit (CLIP_STATE) is set, the CLIP unit increments the CL_INVOCATION_COUNT register for every complete object received from the GS stage.

To maintain a count of application-generated objects, software must clear the CLIP unit's **Statistic Enable** whenever driver-generated objects are rendered.



3D Pipeline - Strips and Fans (SF) Stage

The Strips and Fan (SF) stage of the 3D pipeline is responsible for performing *setup* operations required to rasterize 3D objects.

This functionality is handled completely in hardware, and the SF unit no longer has the ability to spawn threads.

Inputs from CLIP

The following table describes the per-vertex inputs passed to the SF unit from the previous (CLIP) stage of the pipeline.

SF's Vertex Pipeline Inputs

Variable	Type	Description
primType	enum	Type of primitive topology the vertex belongs to. <i>Primitive Assembly</i> for a list of primitive types supported by the SF unit. See <i>3D Pipeline</i> for descriptions of these topologies. Notes: The CLIP unit will convert any primitive with adjacency (3DPRIMxxx_ADJ) it receives from the pipeline into the corresponding primitive without adjacency (3DPRIMxxx). QUADLIST, QUADSTRIP, LINELOOP primitives are not supported by the SF unit. Software must use a GS thread to convert these to some other (supported) primitive type. [DevSNB+] If an object is clipped by the hardware clipper, the CLunit would force this field to <i>3DPRIM_POLYGON</i> . SFunit would process this incoming object just as it would any other <i>3DPRIM_POLYGON</i> . SFunit selects vertex 0 as the provoking vertex.
primStart,primEnd	boolean	Indicate vertex's position within the primitive topology
vInX[]	float	Vertex X position (screen space or NDC space)
vInY[]	float	Vertex Y position (screen space or NDC space)
vInZ[]	float	Vertex Z position (screen space or NDC space)
vInInvW[]	float	Reciprocal of Vertex homogeneous (clip space) W
hVUE[]	URB address	Points to the vertex's data stored in the URB (one VUE handle per vertex)
renderTargetArrayIndex	uint	Index of the render target (array element or 3D slice), clamped to 0 by the GS unit if the max value was exceeded. If this vertex is the leading vertex of an object within the primitive topology, this value will be associated with that object in subsequent processing.
viewPortIndex	uint	Index of a viewport transform matrix within the SF_VIEWPORT structure used to



Variable	Type	Description
		perform Viewport Transformation on object vertices and scissor operations on an object. If this vertex is the leading vertex of an object within the primitive topology, this value will be associated with that object in the Viewport Transform and Scissor subfunctions, otherwise the value is ignored. Note that for primitive topologies with vertices shared between objects, this means a shared vertex may be subject to multiple Viewport Transformation operations if the viewPortIndex varies within the topology.
pointSize	uint	If this vertex is within a POINTLIST[_BF] primitive topology, this value specifies the screen space size (width,height) of the square point to be rasterized about the vertex position. Otherwise the value is ignored.

Attribute Setup/Interpolation Process

The following sections describe the Attribute Setup/Interpolation Process.

Attribute Setup/Interpolation Process

Hardware computes all needed parameters, as there is no setup thread.

Outputs to WM

The outputs from the SF stage to the WM stage are mostly comprised of implementation-specific information required for the rasterization of objects. The types of information is summarized below, but as the interface is not exposed to software a detailed discussion is not relevant to this specification.

- PrimType of the object
- VPIndex, RTAIndex associated with the object
- Coefficients for Z, 1/W, perspective and non-perspective b1 and b2 per vertex, and attribute vertex deltas a0, a1, and a2 per attribute.
- Information regarding the X,Y extent of the object (e.g., bounding box, etc.).
- Edge or line interpolation information (e.g., edge equation coefficients, etc.).
- Information on where the WM is to start rasterization of the object.
- Object orientation (front/back-facing).
- Last Pixel indication (for line drawing).

Primitive Assembly

The first subfunction within the SF unit is *Primitive Assembly*. Here 3D primitive vertex information is buffered and, when a sufficient number of vertices are received, converted into basic 3D objects which are then passed to the Viewport Transformation subfunction.



The number of vertices passed with each primitive is constrained by the primitive type. *Primitive Assembly*. Passing any other number of vertices results in UNDEFINED behavior. Note that this restriction only applies to primitive output by GS threads (which is under control of the GS kernel). See the Vertex Fetch chapter for details on how the VF unit automatically removes incomplete objects resulting from processing a 3DPRIMITIVE command.

SF-Supported Primitive Types & Vertex Count Restrictions

primType	VertexCount Restriction
3DPRIM_TRILIST	nonzero multiple of 3
3DPRIM_TRISTRIP 3DPRIM_TRISTRIP_REVERSE	>=3
3DPRIM_TRIFAN 3DPRIM_TRIFAN_NOSTIPPLE 3DPRIM_POLYGON	>=3
3DPRIM_LINELIST	nonzero multiple of 2
3DPRIM_LINESTRIP 3DPRIM_LINESTRIP_CONT 3DPRIM_LINESTRIP_BF 3DPRIM_LINESTRIP_CONT_BF	>=2
3DPRIM_RECTLIST	nonzero multiple of 3
3DPRIM_POINTLIST 3DPRIM_POINTLIST_BF	nonzero

Primitive Assembly for a list of the 3D object types.

3D Object Types

objectType	generated by primType	Vertices/Object
3DOBJ_POINT	3DPRIM_POINTLIST 3DPRIM_POINTLIST_BF	1
3DOBJ_LINE	3DPRIM_LINELIST 3DPRIM_LINESTRIP 3DPRIM_LINESTRIP_CONT 3DPRIM_LINESTRIP_BF 3DPRIM_LINESTRIP_CONT_BF	2
3DOBJ_TRIANGLE	3DPRIM_TRILIST 3DPRIM_TRISTRIP 3DPRIM_TRISTRIP_REVERSE 3DPRIM_TRIFAN	3



objectType	generated by primType	Vertices/Object
	3DPRIM_TRIFAN_NOSTIPPLE 3DPRIM_POLYGON	
3DOBJ_RECTANGLE	3DPRIM_RECTLIST	3 (expanded to 4 in RectangleCompletion)

Primitive Assembly for the outputs of Primitive Decomposition.

Primitive Decomposition Outputs

Variable	Type	Description
objectType	enum	Type of object. <i>Primitive Assembly</i>
nV	uint	The number of object vertices passed to Object Setup. <i>Primitive Assembly</i>
v[0..nV-1]*	various	Data arrays associated with <u>object</u> vertices. Data in the array consists of X, Y, Z, invW and a pointer to the other vertex attributes. These additional attributes are not used by directly by the 3D fixed functions but are made available to the SF thread. The number of valid vertices depends on the object type. <i>Primitive Assembly</i>
invertOrientation	enum	Indicates whether the orientation (CW or CCW winding order) of the vertices of a triangle object should be inverted. Ignored for non-triangle objects.
backFacing	enum	Valid only for points and line objects, indicates a back facing object. This is used later for culling.
provokingVtx	uint	Specifies the index (into the v[] arrays) of the vertex considered the <i>provoking</i> vertex (for flat shading). The selection of the provoking vertex is programmable via SF_STATE (xxx Provoking Vertex Select state variables.)
polyStippleEnable	boolean	TRUE if Polygon Stippling is enabled. FALSE for TRIFAN_NOSTIPPLE. Ignored for non-triangle objects.
continueStipple	boolean	Only applies to line objects. TRUE if Line Stippling should be continued (i.e., not reset) from where the previous line left off. If FALSE, Line Stippling is reset for each line object.
renderTargetIndex	uint	Index of the render target (array element or 3D slice), clamped to 0 by the GS unit if the max value was exceeded. This value is simply passed in SF thread payloads and not used within the SF unit.
viewPortIndex	uint	Index of a viewport transform matrix within the SF_VIEWPORT structure used to perform Viewport Transformation on object vertices and scissor operations on an object.
pointSize	unit	For point objects, this value specifies the screen space size (width,height) of the square point to be rasterized about the vertex position. Otherwise the value is ignored.



The following table defines, for each primitive topology type, which vertex's VPIndex/RTAIndex applies to the objects within the topology.

VPIndex/RTAIndex Selection

PrimTopologyType	Viewport Index Usage
POINTLIST POINTLIST_BF	Each vertex supplies the VPIndex for the corresponding point object
LINELIST	The leading vertex of each line supplies the VPIndex for the corresponding line object. V0.VPIndex → Line(V0,V1) V2.VPIndex → Line(V2,V3) ...
LINESTRIP LINESTRIP_BF LINESTRIP_CONT LINESTRIP_CONT_BF	The leading vertex of each line segment supplies the VPIndex for the corresponding line object. V0.VPIndex → Line(V0,V1) V1.VPIndex → Line(V1,V2) ... NOTE: If the VPIndex changes within the topology, shared vertices will be processed (mapped) multiple times.
TRILIST RECTLIST	The leading vertex of each triangle/rect supplies the VPIndex for the corresponding triangle/rect objects. V0.VPIndex → Tri(V0,V1,V2) V3.VPIndex → Tri(V3,V4,V5) ...
TRISTRIP TRISTRIP_REVERSE	The leading vertex of each triangle supplies the VPIndex for the corresponding triangle object. V0.VPIndex → Tri(V0,V1,V2) V1.VPIndex → Tri(V1,V2,V3) ... NOTE: If the VPIndex changes within the primitive, shared vertices will be processed (mapped) multiple times.
TRIFAN TRIFAN_NOSTIPPLE POLYGON	The first vertex (V0) supplies the VPIndex for all triangle objects.



Point List Decomposition

The 3DPRIM_POINTLIST and 3DPRIM_POINTLIST_BACKFACING primitives specify a list of independent points.

3DPRIM_POINTLIST Primitive

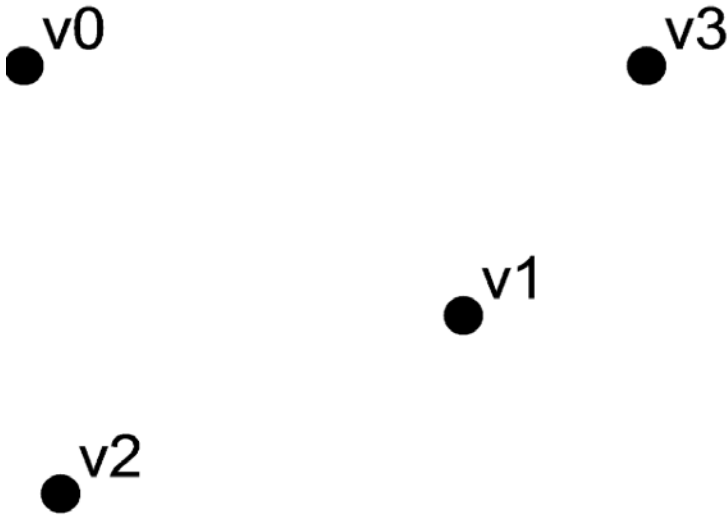

The decomposition process divides the list into a series of basic 3DOBJ_POINT objects that are then passed individually and in order to the Object Setup subfunction. The *provokingVertex* of each object is, by definition, v[0].

Points have no winding order, so the primitive command is used to explicitly state whether they are back-facing or front-facing points. Primitives of type 3DPRIM_POINTLIST_BACKFACING are decomposed exactly the same way as 3DPRIM_POINTLIST primitives, but the *backFacing* variable is set for resulting point objects being passed on to object setup.

```
PointListDecomposition() {
  objectType = 3DOBJ_POINT
  nV = 1
  provokingVtx = 0
  if (primType == 3DPRIM_POINTLIST)
    backFacing = FALSE
  else // primType == 3DPRIM_POINTLIST_BACKFACING
    backFacing = TRUE
  for each (vertex I in [0..vertexCount-1]) {
    v[0] ← vIn[i] // copy all arrays (e.g., v[]X, v[]Y, etc.)
    ObjectSetup()
  }
```



```
}
```

Line List Decomposition

The 3DPRIM_LINELIST primitive specifies a list of independent lines.

3DPRIM_LINELIST Primitive

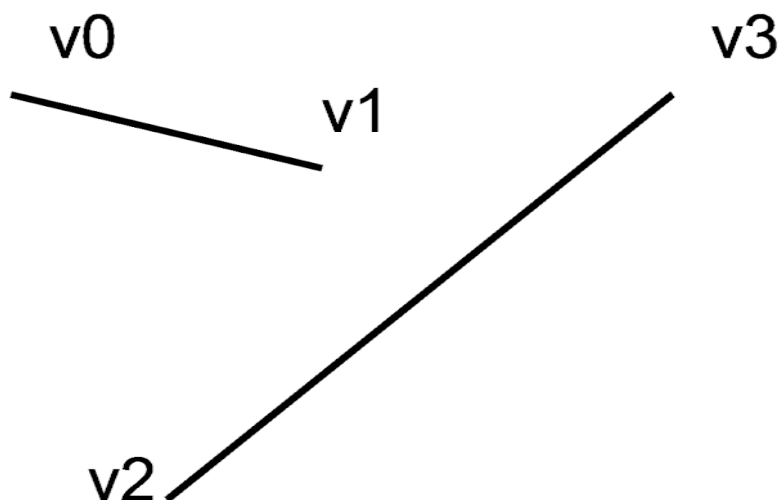

The decomposition process divides the list into a series of basic 3DOBJ_LINE objects that are then passed individually and in order to the Object Setup stage. The lines are generated with the following object vertex order: *v0, v1*; *v2, v3*; and so on. The *provokingVertex* of each object is taken from the **Line List/Strip Provoking Vertex Select** state variable, as programmed via SF_STATE.

```

LineListDecomposition() {
  objectType = 3DOBJ_LINE
  nV = 2
  provokingVtx = Line List/Strip Provoking Vertex Select
  continueStipple = FALSE
  for each (vertex I in [0..vertexCount-2] by 2) {
    v[0] arrays ← vIn[i] arrays
    v[1] arrays ← vIn[i+1] arrays
    ObjectSetup()
  }
}

```



Line Strip Decomposition

The 3DPRIM_LINESTRIP, 3DPRIM_LINESTRIP_CONT, 3DPRIM_LINESTRIP_BF, and 3DPRIM_LINESTRIP_CONT_BF primitives specify a list of connected lines.

3DPRIM_LINESTRIP_xxx Primitive

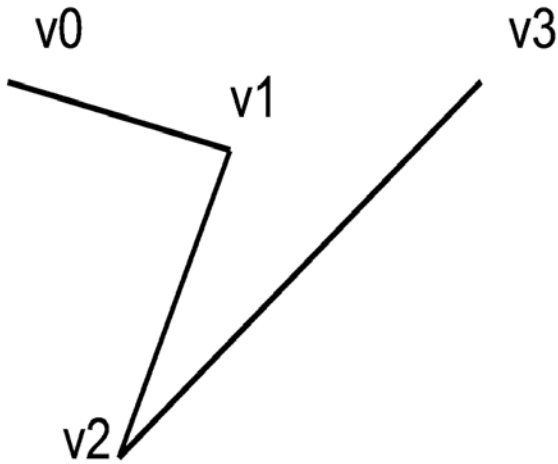

The decomposition process divides the strip into a series of basic 3DOBJ_LINE objects that are then passed individually and in order to the Object Setup stage. The lines are generated with the following object vertex order: v0,v1; v1,v2; and so on. The *provokingVertex* of each object is taken from the **Line List/Strip Provoking Vertex Select** state variable, as programmed via SF_STATE.

Lines have no winding order, so the primitive command is used to explicitly state whether they are back-facing or front-facing lines. Primitives of type 3DPRIM_LINESTRIP[_CONT]_BF are decomposed exactly the same way as 3DPRIM_LINESTRIP[_CONT] primitives, but the *backFacing* variable is set for the resulting line objects being passed on to object setup. Likewise 3DPRIM_LINESTRIP_CONT[_BF] primitives are decomposed identically to basic line strips, but the *continueStipple* variable is set to true so that the line stipple pattern will pick up from where it left off with the last line primitive, rather than being reset.

```
LineStripDecomposition() {  
  objectType = 3DOBJ_LINE  
  nV = 2  
  provokingVtx = Line List/Strip Provoking Vertex Select  
  if (primType == 3DPRIM_LINESTRIP) {  
    backFacing = FALSE  
    continueStipple = FALSE  
  } else if (primType == 3DPRIM_LINESTRIP_BF) {  
    backFacing = TRUE  
    continueStipple = FALSE  
  }  
}
```

```

} else if (primType == 3DPRIM_LINESTRIP_CONT) {
    backFacing = FALSE
    continueStipple = TRUE
} else if (primType == 3DPRIM_LINESTRIP_CONT_BF) {
    backFacing = TRUE
    continueStipple = TRUE
}
for each (vertex I in [0..vertexCount-1]) {
v[0] arrays ← vIn[i] arrays
v[1] arrays ← vIn[i+1] arrays
ObjectSetup()
continueStipple = TRUE
}
}

```

Triangle List Decomposition

The 3DPRIM_TRILIST primitive specifies a list of independent triangles.

3DPRIM_TRILIST Primitive

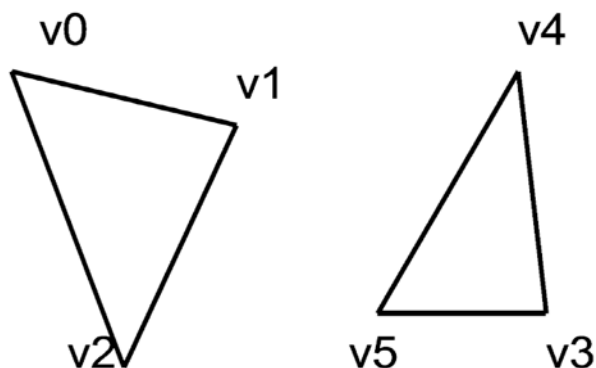

The decomposition process divides the list into a series of basic 3DOBJ_TRIANGLE objects that are then passed individually and in order to the Object Setup stage. The triangles are generated with the following object vertex order: v0,v1,v2; v3,v4,v5; and so on. The *provokingVertex* of each object is taken from the **Triangle List/Strip Provoking Vertex Select** state variable, as programmed via SF_STATE.

```

TriangleListDecomposition() {
objectType = 3DOBJ_TRIANGLE
    nV = 3
invertOrientation = FALSE
}

```



```
provokingVtx = Triangle List/Strip Provoking Vertex Select
polyStippleEnable = TRUE
for each (vertex I in [0..vertexCount-3] by 3) {
v[0] arrays ← vIn[i] arrays
v[1] arrays ← vIn[i+1] arrays
v[2] arrays ← vIn[i+2] arrays
ObjectSetup()
    }
}
```

Triangle Strip Decomposition

The 3DPRIM_TRISTRIP and 3DPRIM_TRISTRIP_REVERSE primitives specify a series of triangles arranged in a strip, as illustrated below.

3DPRIM_TRISTRIP[_REVERSE] Primitive

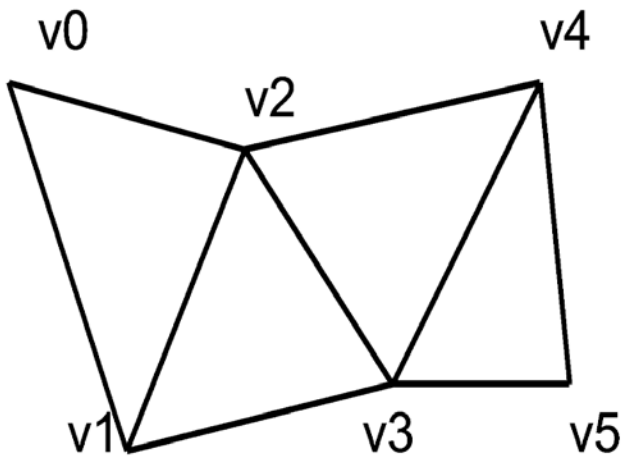

The decomposition process divides the strip into a series of basic 3DOBJ_TRIANGLE objects that are then passed individually and in order to the Object Setup stage. The triangles are generated with the following object vertex order: v0,v1,v2; v1,v2,v3; v2,v3,v4; and so on. Note that the *winding order* of the vertices alternates between CW (clockwise), CCW (counter-clockwise), CW, etc. The *provokingVertex* of each object is taken from the **Triangle List/Strip Provoking Vertex Select** state variable, as programmed via SF_STATE.

The 3D pipeline uses the winding order of the vertices to distinguish between front-facing and back-facing triangles (*Triangle Orientation (Face) Culling* below). Therefore, the 3D pipeline must account for the alternation of winding order in strip triangles. The *invertOrientation* variable is generated and used for this purpose.



To accommodate the situation where the driver is forced to break an input strip primitive into multiple tristrip primitive commands (e.g., due to ring or batch buffer size restrictions), two tristrip primitive types are supported. 3DPRIM_TRISTRIP is used for the initial section of a strip, and wherever a continuation of a strip starts with a triangle with a CW winding order. 3DPRIM_TRISTRIP_REVERSE is used for a continuation of a strip that starts with a triangle with a CCW winding order.

```
TriangleStripDecomposition() {  
  objectType = 3DOBJ_TRIANGLE  
  nV = 3  
  provokingVtx = Triangle List/Strip Provoking Vertex Select  
  if (primType == 3DPRIM_TRISTRIP)  
    invertOrientation = FALSE  
  else // primType == 3DPRIM_TRISTRIP_REVERSE  
    invertOrientation = TRUE  
  polyStippleEnable = TRUE  
  for each (vertex I in [0..vertexCount-3]) {  
    v[0] arrays ← vIn[i] arrays  
    v[1] arrays ← vIn[i+1] arrays  
    v[2] arrays ← vIn[i+2] arrays  
    ObjectSetup()  
    invertOrientation = ! invertOrientation  
  }  
}
```

Triangle Fan Decomposition

The 3DPRIM_TRIFAN and 3DPRIM_TRIFAN_NOSTIPPLE primitives specify a series of triangles arranged in a fan, as illustrated below.



3DPRIM_TRIFAN Primitive

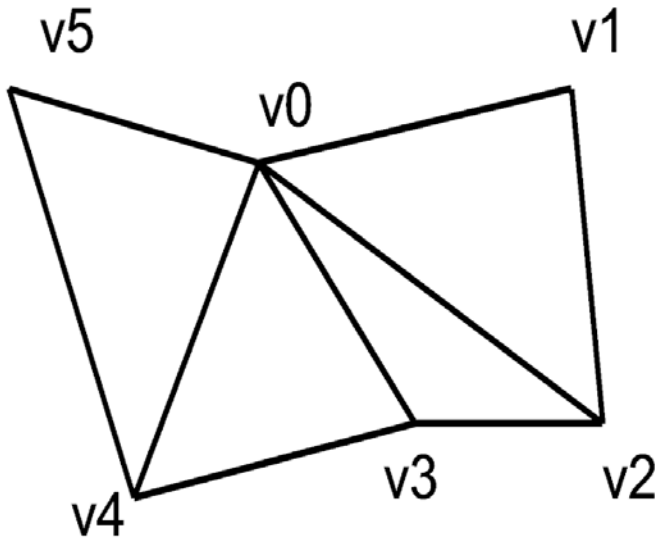

The decomposition process divides the fan into a series of basic 3DOBJ_TRIANGLE objects that are then passed individually and in order to the Object Setup stage. The triangles are generated with the following object vertex order: v0,v1,v2; v0,v2,v3; v0,v3,v4; and so on. As there is no alternation in the vertex winding order, the *invertOrientation* variable is output as FALSE unconditionally. The *provokingVertex* of each object is taken from the **Triangle Fan Provoking Vertex** state variable, as programmed via SF_STATE.

Primitives of type 3DPRIM_TRIFAN_NOSTIPPLE are decomposed exactly the same way, except the *polyStippleEnable* variable is FALSE for the resulting objects being passed on to object setup. This will inhibit polygon stipple for these triangle objects.

```
TriangleFanDecomposition() {  
  objectType = 3DOBJ_TRIANGLE  
  nV = 3  
  invertOrientation = FALSE  
  provokingVtx = Triangle Fan Provoking Vertex Select  
  if (primType == 3DPRIM_TRIFAN)  
    polyStippleEnable = TRUE  
  else // primType == 3DPRIM_TRIFAN_NOSTIPPLE  
    polyStippleEnable = FALSE  
  v[0] arrays ← vIn[0] arrays // the 1st vertex is common  
  for each (vertex I in [1..vertexCount-2]) {  
    v[1] arrays ← vIn[i] arrays
```

```

v[2] arrays ← vIn[i+1] arrays
ObjectSetup()
    }
}

```

Polygon Decomposition

The 3DPRIM_POLYGON primitive is identical to the 3DPRIM_TRIFAN primitive with the exception that the *provokingVtx* is overridden with 0. This support has been added specifically for OpenGL support, avoiding the need for the driver to change the provoking vertex selection when switching between trifan and polygon primitives.

Rectangle List Decomposition

The 3DPRIM_RECTLIST primitive command specifies a list of independent, axis-aligned rectangles. Only the lower right, lower left, and upper left vertices (in that order) are included in the command – the upper right vertex is derived from the other vertices (in Object Setup).

3DPRIM_RECTLIST Primitive

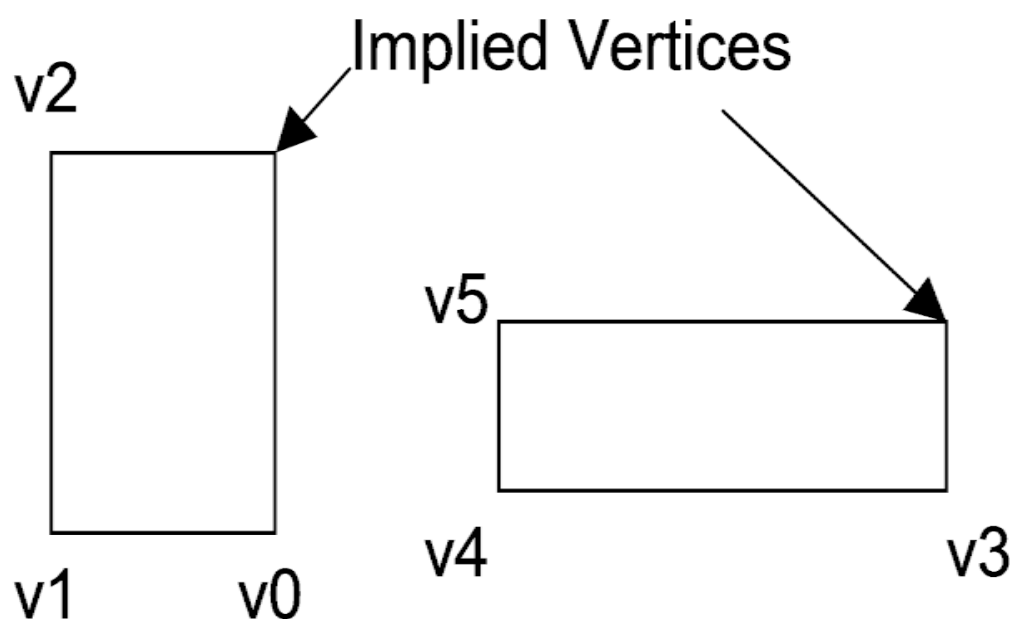

The decomposition of the 3DPRIM_RECTLIST primitive is identical to the 3DPRIM_TRILIST decomposition, with the exception of the *objectType* variable.

```

RectangleListDecomposition() {
    objectType = 3DOBJ_RECTANGLE
    nV = 3
}

```



```
invertOrientation = FALSE
provokingVtx = 0
for each (vertex I in [0..vertexCount-3] by 3) {
v[0] arrays ← vIn[i] arrays
v[1] arrays ← vIn[i+1] arrays
v[2] arrays ← vIn[i+2] arrays
ObjectSetup()
    }
}
```



Object Setup

The Object Setup subfunction of the SF stage takes the post-viewport-transform data associated with each vertex of a basic object and computes various parameters required for scan conversion. This includes generation of implied vertices, translations and adjustments on vertex positions, and culling (removal) of certain classes of objects. The final object information is passed to the Windower/Masker (WM) stage where the object is rasterized into pixels.

Invalid Position Culling (Pre/Post-Transform)

At input the the SF stage, any objects containing a floating-point NaN value for Position X, Y, Z, or RHW will be unconditionally discarded. Note that this occurs on an object (not primitive) basis.

If Viewport Transformation is enabled, any objects containing a floating-point NaN value for post-transform Position X, Y or Z will be unconditionally discarded.

Viewport Transformation

If the **Viewport Transform Enable** bit of SF_STATE is ENABLED, a viewport transformation is applied to each vertex of the object.

The VPIndex associated with the leading vertex of the object is used to obtain the **Viewport Matrix Element** data from the corresponding element of the SF_VIEWPORT structure in memory. For each object vertex, the following scale and translate transformation is applied to the position coordinates:

$$x' = \mathbf{m00} * x + \mathbf{m30}$$

$$y' = \mathbf{m11} * y + \mathbf{m31}$$

$$z' = \mathbf{m22} * z + \mathbf{m32}$$

Software is responsible for computing the matrix elements from the viewport information provided to it from the API.

Destination Origin Bias

The positioning of the pixel sampling grid is programmable and is controlled by the **Destination Origin Horizontal/Vertical Bias** state variables (set via SF_STATE). If these bias values are both 0, pixels are sampled on an integer grid. Pixel (0,0) will be considered inside the object if the sample point at XY coordinate (0,0) falls within the primitive.

If the bias values are both 0.5, pixels are sampled on a *half* integer grid (i.e., X.5, Y.5). Pixel (0,0) will be considered inside the object if the sample point at XY coordinate (0.5,0.5) falls within the primitive. This positioning of the sample grid corresponds with the OpenGL rasterization rules, where *fragment centers* lay on a half-integer grid. It also corresponds with the Intel740 rasterizer (though that device did not employ *top left* rules).



Note that subsequent descriptions of rasterization rules for the various objects will be with reference to the pixel sampling grid.

Destination Origin Bias

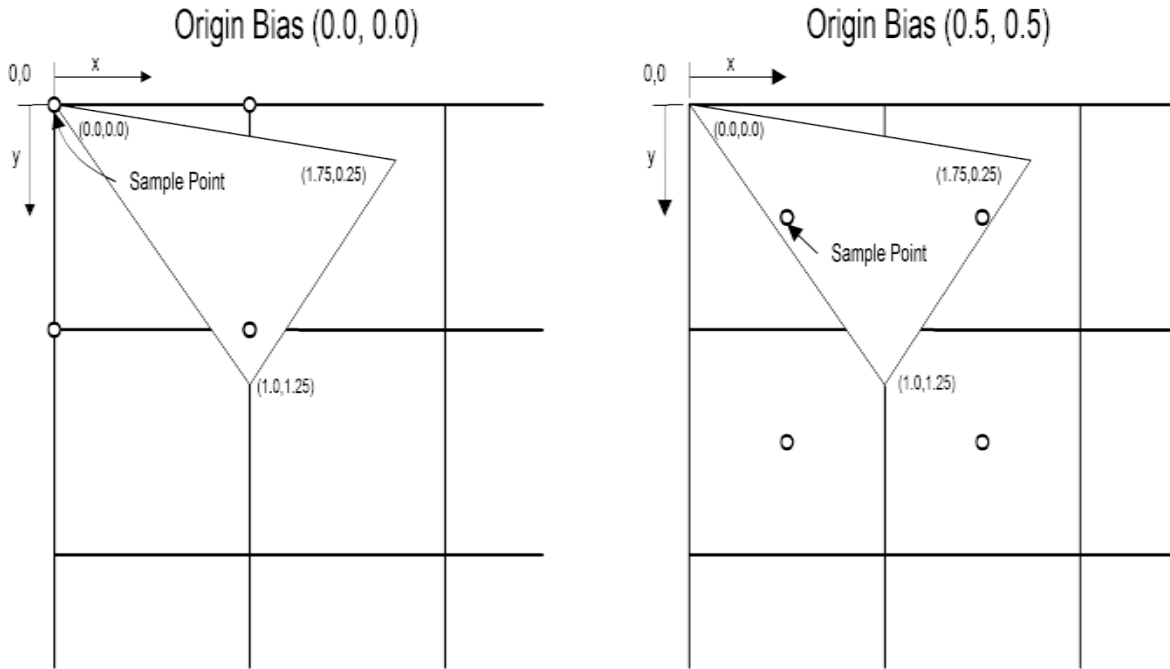

Point Rasterization Rule Adjustment

POINT objects are rasterized as square RECTANGLES, with one exception: The **Point Rasterization Rule** state variable (in SF_STATE) controls the rendering of point object edges that fall directly on pixel sample points, as the treatment of these edge pixels varies between APIs.

RASTRULE_UPPER_LEFT

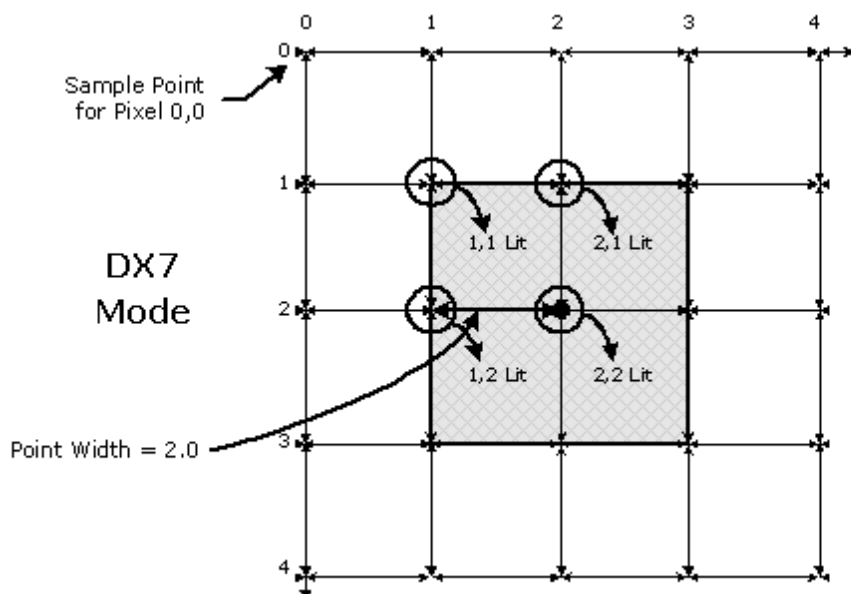

B6846-01

Drawing Rectangle Offset Application

The Drawing Rectangle Offset subfunction offsets the object's vertex X,Y positions by the pixel-exact, unclipped drawing rectangle origin (as programmed via the **Drawing Rectangle Origin X,Y** values in the 3DSTATE_DRAWING_RECTANGLE command). The Drawing Rectangle Offset subfunction (at least with respect to Color Buffer access) is unconditional, and therefore to (effectively) turn off the offset function the origin would need to be set to (0,0). A non-zero offset is typically specified when window-relative or viewport-relative screen coordinates are input to the device. Here the drawing rectangle origin would be loaded with the absolute screen coordinates of the window's or viewport's upper-left corner.

Clipping of objects which extend outside of the Drawing Rectangle occurs later in the pipeline. Note that this clipping is based on the *clipped* draw rectangle (as programmed via the **Clipped Drawing Rectangle** values in the 3DSTATE_DRAWING_RECTANGLE command), which must be clamped by software to the rendertarget boundaries. The unclipped drawing rectangle origin, however, can extend outside the screen limits in order to support windows whose origins are moved off-screen. This is illustrated in the following diagrams.



Onscreen Draw Rectangle

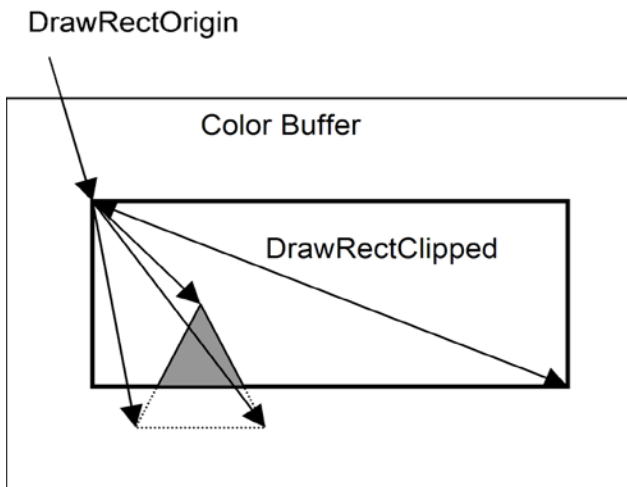

Partially-offscreen Draw Rectangle

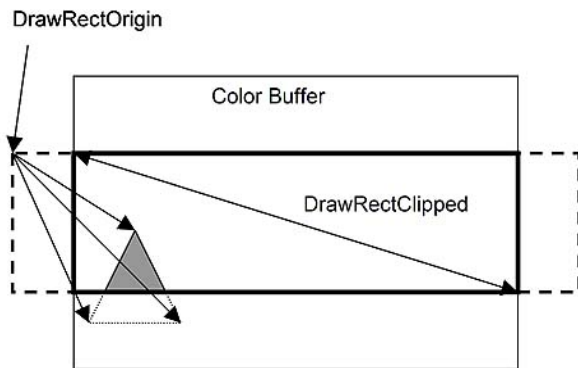

3DSTATE_DRAWING_RECTANGLE

Point Width Application

This stage of the pipeline applies only to 3DOBJ_POINT objects. Here the point object is converted from a single vertex to four vertices located at the corners of a square centered at the point's X,Y position. The width and height of the square are specified by a *point width* parameter. The **Point Width Source** value in SF_STATE determines the source of the point width parameter: the point width is either taken from the **Point Width** value programmed in SF_STATE or the PointWidth specified with the vertex (as read back from the vertex VUE earlier in the pipeline).

The corner vertices are computed by adding and subtracting one half of the point width. *Point Width Application*.

Point Width Application

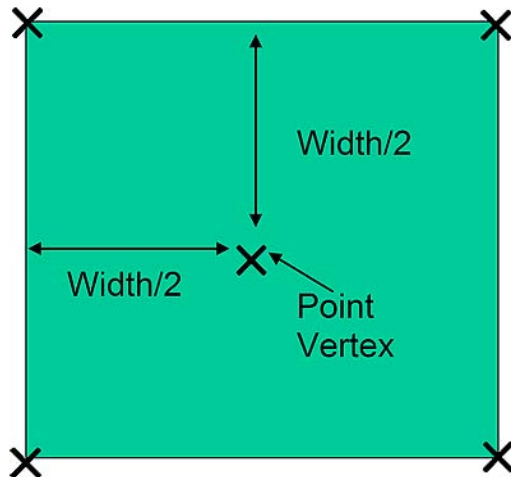

Z and W vertex attributes are copied from the single point center vertex to each of the four corner vertices.

Rectangle Completion

This stage of the pipeline applies only to 3DOBJ_RECTANGLE objects. Here the X,Y coordinates of the 4th (upper right) vertex of the rectangle object is computed from the first 3 vertices as shown in the following diagram. The other vertex attributes assigned to the implied vertex (v[3]) are UNDEFINED as they are not used. The Object Setup subfunction will use the values at only the first 3 vertices to compute attribute interpolants used across the entire rectangle.

Rectangle Completion

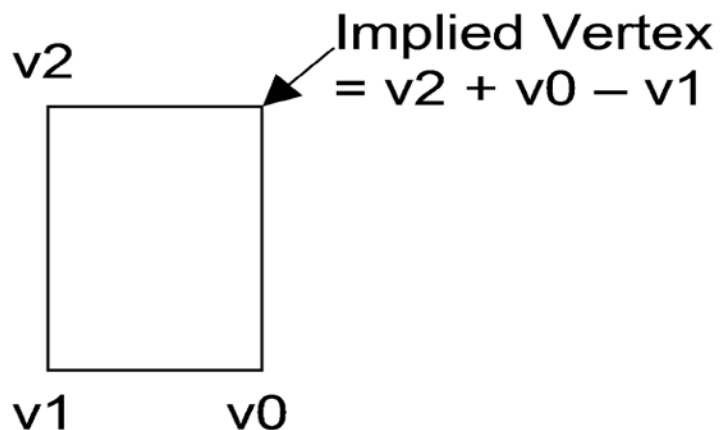



Vertex XY Clamping and Quantization

At this stage of the pipeline, vertex X and Y positions are in continuous screen (pixel) coordinates. These positions are quantized to subpixel precision by rounding the incoming values to the nearest subpixel (using round-to-nearest-or-even rules matching the DirectX reference device). The device supports rasterization with either 4 or 8 fractional (subpixel) position bits, as specified by the **Vertex SubPixel Precision Select** bit of SF_STATE.

The vertex X and Y screenspace coordinates are also *clamped* to the fixed-point "guardband" range supported by the rasterization hardware, as listed in the following table:

Per-Device Guardband Extents

Project	Supported X,Y ScreenSpace "Guardband" Extent	Maximum Post-Clamp Delta (X or Y)
HSW	[-32K,32K-1]	N/A

Note that this clamping occurs after the Drawing Rectangle Origin has been applied and objects have been expanded (i.e., points have been expanded to squares, etc.). In almost all circumstances, if an object's vertices are actually modified by this clamping (i.e., had X or Y coordinates outside of the guardband extent the rendered object will not match the intended result. Therefore software should take steps to ensure that this does not happen – e.g., by clipping objects such that they do not exceed these limits after the Drawing Rectangle is applied.

In addition, in order to be correctly rendered, objects must have a screenspace bounding box not exceeding 8K in the X or Y direction. This additional restriction must also be comprehended by software, i.e., enforced by use of clipping.

Degenerate Object Culling

At this stage of the pipeline, *degenerate* objects are discarded. This operation is automatic and cannot be disabled. (The object rasterization rules would by definition cause these objects to be *invisible* – this culling operation is mentioned here to reinforce that the device implementation optimizes these degeneracies as early as possible).

Degenerate Object Culling for definitions of degenerate objects.

Degenerate Objects

objType	Degenerate Object Definition
3DOBJ_POINT	Two or more corner vertices are coincident (i.e., the radius quantized to zero)
3DOBJ_LINE	The endpoints are coincident
3DOBJ_TRIANGLE	All three vertices are collinear or any two vertices are coincident and SOLID fill mode applies to the triangle
3DOBJ_RECTANGLE	Two or more corner vertices are coincident

Triangle Orientation (Face) Culling

At this stage of the pipeline, 3DOBJ_TRIANGLE objects can be optionally discarded based on the *face orientation* of the object. This culling operation does not apply to the other object types.

This operation is typically called *back face culling*, though front facing objects (or all 3DOBJ_TRIANGLE objects) can be selected to be discarded as well. Face culling is typically used to eliminate triangles facing away from the viewer, thus reducing rendering time.

The *winding order* of a triangle is defined by the the triangle vertex's 2D (X,Y) screen space position when traversed from v0 to v1 to v2. That traversal proceeds in either a clockwise (CW) or counter-clockwise (CCW) direction. The *winding order* of a triangle is defined by the the triangle vertex's 2D (X,Y) screen space position when traversed from v0 to v1 to v2. That traversal will proceed in either a clockwise (CW) or counter-clockwise (CCW) direction. A degenerate triangle is considered *backfacing*, regardless of the FrontWinding state.

Triangle Winding Order

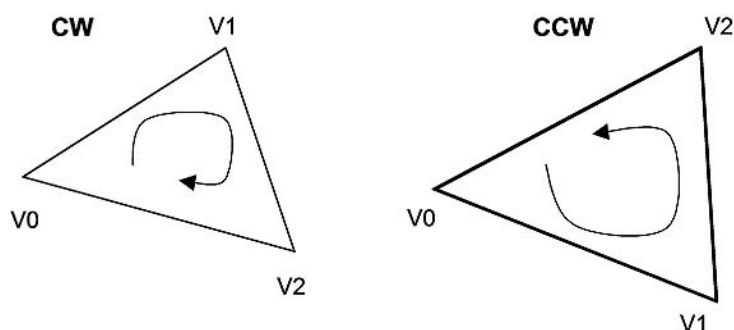

The **Front Winding** state variable in SF_STATE controls whether CW or CCW triangles are considered as having a *front-facing* orientation (at which point non-front-facing triangles are considered *back-facing*). The internal variable *invertOrientation* associated with the triangle object is then used to determine whether the orientation of a that triangle should be inverted. Recall that this variable is set in the Primitive Decomposition stage to account for the alternating orientations of triangles in strip primitives resulting from the ordering of the vertices used to process them.

The **Cull Mode** state variable in SF_STATE specifies how triangles are discarded according to their resultant orientation. See [Degenerate Objects](#).

Cull Mode

CullMode	Definition
CULLMODE_NONE	The face culling operation is disabled.
CULLMODE_FRONT	Triangles with <i>front facing</i> orientation are discarded.
CULLMODE_BACK	Triangles with <i>back facing</i> orientation are discarded.
CULLMODE_BOTH	All triangles are discarded.



Scissor Rectangle Clipping

A *scissor* operation can be used to restrict the extent of rendered pixels to a screen-space aligned rectangle. If the scissor operation is enabled, portions of objects falling outside of the intersection of the scissor rectangle and the clipped draw rectangle are clipped (pixels discarded).

The scissor operation is enabled by the **Scissor Rectangle Enable** state variable in SF_STATE. If enabled, the VPIIndex associated with the leading vertex of the object is used to select the corresponding SF_VIEWPORT structure. Up to 16 structures are supported. The **Scissor Rectangle X,Y Min,Max** fields of the SF_VIEWPORT structure defines a scissor rectangle as a rectangle in integer pixel coordinates relative to the (unclipped) origin of the Drawing Rectangle. The scissor rectangle is defined relative to the Drawing Rectangle to better support the OpenGL API. (OpenGL specifies the *Scissor Box* in window-relative coordinates). This allows instruction buffers with embedded Scissor Rectangle definitions to remain valid even after the destination window (drawing rectangle) moves.

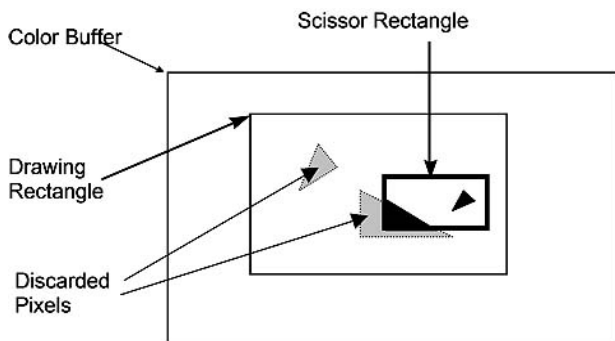

Specifying either scissor rectangle $xmin > xmax$ or $ymin > ymax$ will cause all polygons to be discarded for a given viewport (effectively a null scissor rectangle).

Line Rasterization

The device supports three styles of line rendering: *zero-width (cosmetic)* lines, *non-antialiased* lines, and *antialiased* lines. Non-antialiased lines are rendered as a polygon having a specified width as measured parallel to the major axis of the line. Antialiased lines are rendered as a rectangle having a specified width measured perpendicular to the line connecting the vertices.

The functions required to render lines are split between the SF and WM units. The SF unit is responsible for computing the overall geometry of the object to be rendered, including the pixel-exact bounding box, edge equations, etc., and therefore is provided with the screen-geometry-related state variables. The WM unit performs the actual scan conversion, determining the exact pixels included/excluded and coverage values for anti-aliased lines.

Zero-Width (Cosmetic) Line Rasterization

Note: The specification of zero-width line rasterization would be more correctly included in the WM Unit chapter, though is being included here to keep it with the rasterization details of the other line types.

When the **Line Width** is set to zero, the device will use special rules to rasterize zero-width (*cosmetic*) lines. The **Anti-Aliasing Enable** state variable is ignored when **Line Width** is zero.

When the **LineWidth** is set to zero, the device will use special rules to rasterize *cosmetic* lines. The rasterization rules also comply with the OpenGL conformance requirements (for 1-pixel wide non-smooth lines). Refer to the appropriate API specifications for details on these requirements.

The GIQ rules basically intersect the directed, ideal line connecting two endpoints with an array of diamond-shaped areas surrounding pixel sample points. Wherever the line exits a diamond (including passing through a diamond), the corresponding pixel is lit. Special rules are used to define the subpixel locations that are considered interior to the diamonds, as a function of the slope of the line. When a line ends in a diamond (and therefore does not exit that diamond), the corresponding pixel is not drawn. When a line starts in a diamond and exits that diamond, the corresponding pixel is drawn.

GIQ (Diamond) Sampling Rules – Legacy Mode

When the **Legacy Line Rasterization Enable** bit in WM_STATE is ENABLED, zero-width lines are rasterized according to the algorithm presented in this subsection. Also note that the **Last Pixel Enable** bit of SF_STATE controls whether the last pixel of the last line in a LINESTRIP_xxx primitive or the last pixel of each line in a LINELIST_xxx primitive is rendered.

Refer to the following figure, which shows the neighborhood of subpixels around a given pixel sample point. Note that the device divides a pixel into a 16x16 array of subpixels, referenced by their upper left corners.

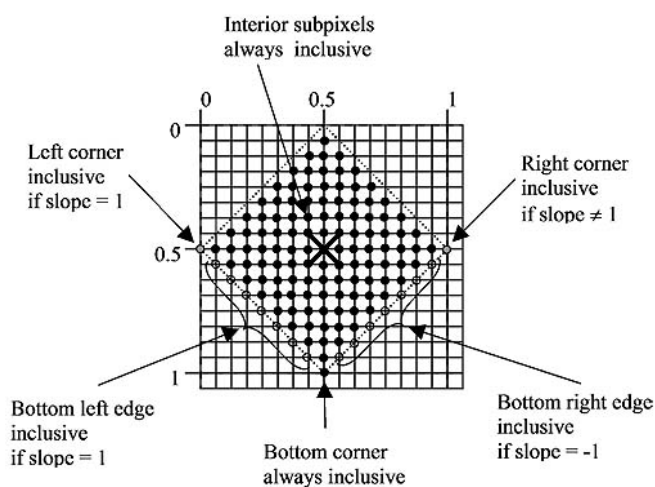

The solid-colored subpixels are considered *interior* to the diamond centered on the pixel sample point. Here the Manhattan distance to the pixel sample point (center) is less than $\frac{1}{2}$.

The subpixels falling on the edges of the diamond (Manhattan distance = $\frac{1}{2}$) are exclusive, with the following exceptions:

1. **The bottom corner subpixel is always inclusive.** This is to ensure that lines with slopes in the open range $(-1,1)$ touch a diamond even when they cross exactly between pixel diamonds.



2. **The right corner subpixel is inclusive as long as the line slope is not exactly one, in which case the left corner subpixel is inclusive.** Including the right corner subpixel ensures that lines with slopes in the range (1, +infinity] or [-infinity, -1) touch a diamond even when they cross exactly between pixel diamonds. Including the left corner on slope=1 lines is required for proper handling of slope=1 lines (see (3) below) – where if the right corner was inclusive, a slope=1 line falling exactly between pixel centers would wind up lighting pixel on both sides of the line (not desired).
3. **The subpixels along the bottom left edge are inclusive only if the line slope = 1.** This is to correctly handle the case where a slope=1 line falls enters the diamond through a left or bottom corner and ends on the bottom left edge. One does not consider this *passing through* the diamond (where the normal rules would have us light the pixel). This is to avoid the following case: One slope=1 line segment enters through one corner and ends on the edge, and another (continuation) line segments starts at that point on the edge and exits through the other corner. If simply passing through a corner caused the pixel to be lit, this case would case the pixel to be lit twice – breaking the rule that connected line segments should not cause double-hits or missing pixels. So, by considering the entire bottom left edge as *inside* for slope=1 lines, we will only light the pixel when a line passes through the entire edge, or starts on the edge (or the left or bottom corner) and exits the diamond.
4. **The subpixels along the bottom right edge are inclusive only if the line slope = -1.** Similar case as (3), except slope=-1 lines require the bottom right edge to be considered inclusive.

The following equation determines whether a point (point.x, point.y) is inside the diamond of the pixel sample point (sample.x, sample.y), given additional information about the slope (slopePosOne, slopeNegOne).

```
delta_x           = point.x - sample.x
delta_y           = point.y - sample.y
distance          = abs(delta_x) + abs(delta_y)
interior          = (distance < 0.5)
bottom_corner    = (delta_x == 0.0) && (delta_y == 0.5)
left_corner      = (delta_x == -0.5) && (delta_y == 0.0)
right_corner     = (delta_x == 0.5) && (delta_y == 0.0)
bottom_left_edge = (distance == 0.5) && (delta_x < 0) && (delta_y > 0)
bottom_right_edge = (distance == 0.5) && (delta_x > 0) && (delta_y > 0)

inside = interior || bottom_corner || (slopePosOne ? left_corner : right_corner) ||
(slopePosOne && left_edge) || (slopeNegOne && right_edge)
```

GIQ (Diamond) Sampling Rules – DX10 Mode

When the **Legacy Line Rasterization Enable** bit in WM_STATE is DISABLED, zero-width lines are rasterized according to the algorithm presented in this subsection. Also note that the **Last Pixel Enable** bit of SF_STATE controls whether the last pixel of the last line in a LINESTRIP_xxx primitive or the last pixel of each line in a LINELIST_xxx primitive is rendered.

Refer to the following figure, which shows the neighborhood of subpixels around a given pixel sample point. Note that the device divides a pixel into a 16x16 array of subpixels, referenced by their upper left corners.

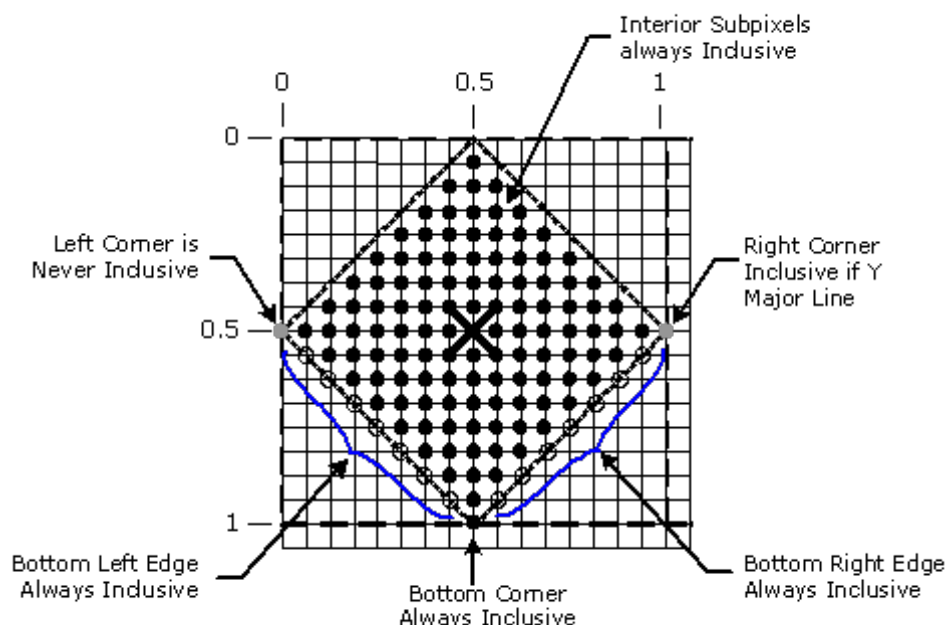

B6849-01

The solid-colored subpixels are considered *interior* to the diamond centered on the pixel sample point. Here the Manhattan distance to the pixel sample point (center) is less than $\frac{1}{2}$.

The subpixels falling on the edges of the diamond (Manhattan distance = $\frac{1}{2}$) are exclusive, with the following exceptions:

1. **The bottom corner subpixel is always inclusive.** This is to ensure that lines with slopes in the open range $(-1,1)$ touch a diamond even when they cross exactly between pixel diamonds.
2. **The right corner subpixel is inclusive as long as the line is not X Major (X Major is defined as $-1 \leq \text{slope} \leq 1$).** Including the right corner subpixel ensures that lines with slopes in the range $(>1, +\infty]$ or $[-\infty, <-1)$ touch a diamond even when they cross exactly between pixel diamonds.
3. **The left corner subpixel is never inclusive.** For Y Major lines, having the right corner subpixel as always inclusive requires that the left corner subpixel should never be inclusive, since a line falling exactly between pixel centers would wind up lighting pixel on both sides of the line (not desired).
4. **The subpixels along the bottom left edge are always inclusive.** This is to correctly handle the case where a line enters the diamond through a left or bottom corner and ends on the bottom left edge. One does not consider this *passing through* the diamond (where the normal rules would have us light the pixel). This is to avoid the following case: One line segment enters through one corner and ends on the edge, and another (continuation) line segments starts at that point on the edge and exits through the other corner. If simply passing through a corner caused the pixel to be



lit, this case would case the pixel to be lit twice – breaking the rule that connected line segments should not cause double-hits or missing pixels. So, by considering the entire bottom left edge as *inside*, we will only light the pixel when a line passes through the entire edge, or starts on the edge (or the left or bottom corner) and exits the diamond.

5. **The subpixels along the bottom right edge are always inclusive.** Same as case as (4), except slope=-1 lines require the bottom right edge to be considered inclusive.

The following equation determines whether a point (point.x, point.y) is inside the diamond of the pixel sample point (sample.x, sample.y), given additional information about the slope (XMajor).

```
delta_x      = point.x - sample.x
delta_y      = point.y - sample.y
distance     = abs(delta_x) + abs(delta_y)
interior     = (distance < 0.5)
bottom_corner = (delta_x == 0.0)  && (delta_y == 0.5)
left_corner  = (delta_x == -0.5) && (delta_y == 0.0)
right_corner = (delta_x == 0.5)  && (delta_y == 0.0)
bottom_left_edge = (distance == 0.5) && (delta_x < 0) && (delta_y > 0)
bottom_right_edge = (distance == 0.5) && (delta_x > 0) && (delta_y > 0)

inside = interior || bottom_corner || (!XMajor && right_corner) || ( bottom_left_edge)
|| ( bottom_right_edge)
```

Non-Antialiased Wide Line Rasterization

Non-anti-aliased, non-zero-width lines are rendered as parallelograms that are centered on, and aligned to, the line joining the endpoint vertices. Pixels sampled interior to the parallelogram are rendered; pixels sampled exactly on the parallelogram edges are rendered according to the polygon *top left* rules.

The parallelogram is formed by first determining the major axis of the line (diagonal lines are considered x-major). The corners of the parallelogram are computed by translating the line endpoints by +/-(**Line Width** / 2) in the direction of the minor axis, as shown in the following diagram.

Non-Antialiased Line Rasterization

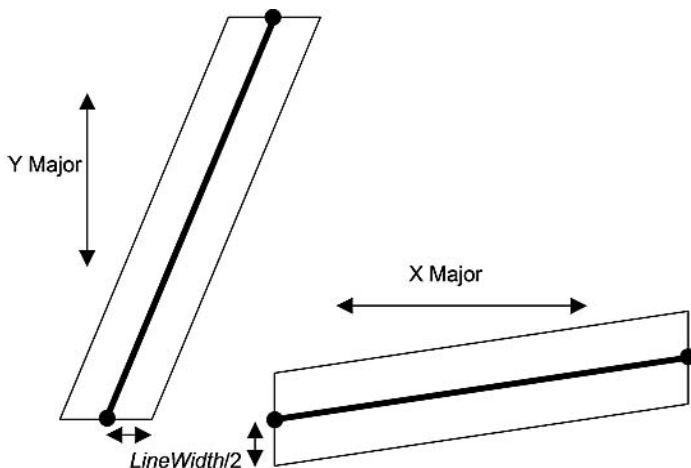

Anti-Aliased Line Rasterization

Anti-aliased lines are rendered as rectangles that are centered on, and aligned to, the line joining the endpoint vertices. For each pixel in the rectangle, a fractional coverage value (referred to as Antialias Alpha) is computed – this coverage value is normally used to attenuate the pixel's alpha in the pixel shader thread. The resultant alpha value is therefore available for use in those downstream pixel pipeline stages to generate the desired effect (e.g., use the attenuated alpha value to modulate the pixel's color, and add the result to the destination color, etc.). Note that software is required to explicitly program the pixel shader and pixel pipeline to obtain the desired anti-aliasing effect – the device simply makes the coverage-attenuated pixel alpha values available for use in the pixel shader.

The dimensions of the rendered rectangle, and the parameters controlling the coverage value computation, are programmed via the **Line Width**, **Line AA Region**, and **Line Cap AA Region** state variables, as shown below. The edges parallel to the line are located at the distance $(LineWidth/2)$ from the line (measured in screen pixel units perpendicular to the line). The end-cap edges are perpendicular to the line and located at the distance $(LineCapAARegion)$ from the endpoints.

Anti-aliased Line Rasterization

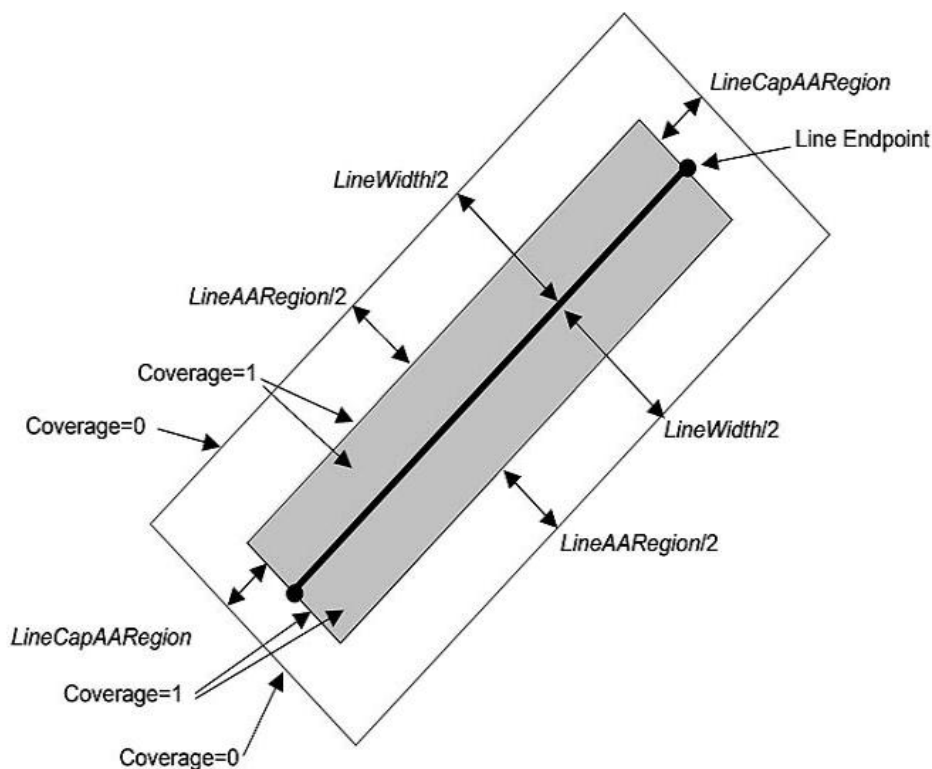

Along the parallel edges, the coverage values ramp from the value 0 at the very edges of the rectangle to the value 1 at the perpendicular distance $(LineAARegion/2)$ from a given edge (in the direction of the line). A pixel's coverage value is computed with respect to the closest edge. In the cases where $(LineAARegion/2) < (LineWidth/2)$, this results in a region of fractional coverage values near the edges of the rectangle, and a region of *fully-covered* coverage values (i.e., the value 1) at the interior of the line. When $(LineAARegion/2) == (LineWidth/2)$, only pixel sample points falling exactly on the line can



generate fully-covered coverage values. If $(LineAARegion/2) > (LineWidth/2)$, no pixels can be fully-covered (it is expected that this case is not typically desired).

Along the end cap edges, the coverage values ramp from the value 1 at the line endpoint to the value 0 at the cap edge – itself at a perpendicular distance (*LineCapAARegion*) from the endpoint. Note that, unlike the line-parallel edges, there is only a single parameter (*LineCapAARegion*) controlling the extension of the line at the end caps and the associated coverage ramp.

The regions near the corners of the rectangle have coverage values influenced by distances from both the line-parallel and end cap edges – here the two coverage values are multiplied together to provide a composite coverage value.

The computed coverage value for each pixel is passed through the Windower Thread Dispatch payload. The Pixel Shader kernel should be passed (unmodified) by the shader to the Render Cache as part of its output message.

3DSTATE_SF

3DSTATE_SF

SF_CLIP_VIEWPORT

The viewport-specific state used by both the SF and CL units (SF_CLIP_VIEWPORT) is stored as an array of up to 16 elements, each of which contains the DWords described below. The start of each element is spaced 16 DWords apart. The location of first element of the array, as specified by both **Pointer to SF_VIEWPORT** and **Pointer to CLIP_VIEWPORT**, is aligned to a 64-byte boundary.

SF_CLIP_VIEWPORT

SCISSOR_RECT



Attribute Interpolation Setup

With the attribute interpolation setup function being implemented in hardware, a number of state fields in 3DSTATE_SF are utilized to control interpolation setup.

Number of SF Output Attributes sets the number of attributes that will be output from the SF stage, not including position. This can be used to specify up to 32, and may differ from the number of input attributes. The number of input attributes is derived from the **Vertex URB Entry Read Length** field. Note that this field is also used to specify whether swizzling is to be performed on Attributes 0-15 or Attributes 16-32. See the state field definition for details.

Attribute Swizzling

The first or last set of 16 attributes can be swizzled according to certain state fields. **Attribute Swizzle Enable** enables the swizzling for all 16 of these attributes, and each of the attributes has a 2-bit **Swizzle Select** field that controls swizzling with the following settings:

- INPUTATTR – This attribute is sourced from AttrInputReg[SourceAttribute].
- INPUTATTR_FACING – This attribute is sourced from AttrInputReg[SourceAttribute] if the object is front-facing, otherwise it is sourced from AttrInputReg[SourceAttribute+1].
- INPUTATTR_W – This attribute is sourced from AttrInputReg[SourceAttribute]. WYZW (the W component of the source is copied to the X component of the destination).
- INPUTATTR_FACING – If the object is front-facing, this attribute is sourced from AttrInputReg[SourceAttribute]. WYZW (the W component of the source is copied to the X component of the destination). If the object is back-facing, this attribute is sourced from AttrInputReg[SourceAttribute+1]. WYZW.

Each of the first or last set of 16 attributes also has a 5-bit **Source Attribute** field which specify, per output attribute (not component), which input attribute sources the output attribute when INPUTATTR is selected for **Swizzle Select**. A **Source Attribute** value of 0 corresponds to the 128-bit attribute immediately following the vertex 4D position. If INPUTATTR_FACING is selected, this specifies the first of two consecutive (front,back) input attributes, where the SourceAttribute value can be an odd or even number (just not 31, as that would place the back-face input attribute past the end of the input max complement of input attributes).

Constant overriding is also available for the first or last set of 16 attributes. Each attribute has a **Constant Source** field which specifies the constant values per swizzled attribute, with the following settings available:

- XYZW = 0000
- XYZW = 0001
- XYZW = 1111

Each channel of each attribute has a **Component Override** field to control whether the corresponding channel is overridden with the constant value defined in **Constant Source**.



Interpolation Modes

All 32 attributes have a **Constant Interpolation Enable** state field bit to specify whether all components of the *post-swizzled* attribute are to be interpolated as constant values (not varying over the pixels of the object). If set, the attribute at the provoking vertex is copied to a0, and a1 and a2 are set to zero – this results in a constant interpolation of the provoking vertex value. If clear, the attribute is linearly interpolated. Attributes 0-15 are further subjected to Wrap Shortest processing on a per-component basis, via the **Attribute WrapShortest Enables** state bitfields. WrapShortest processing modifies the a1 and/or a2 values depending on attribute deltas. All

The table below indicates the output values of a0, a1, and a2 depending on interpolation mode settings.

	a0	a1	a2
Constant	A0	0.0	0.0
Linear	A0	A1-A0	A2-A0
Wrap Shortest	A0	(A1-A0)+1 (A1-A0) <= -0.5	(A2-A0)+1 (A2-A0) <= -0.5
		(A1-A0)-1 (A1-A0) >= 0.5	(A2-A0)-1 (A2-A0) >= 0.5
		(A1-A0) otherwise	(A2-A0) otherwise

Point Sprites

Normally all vertex attributes (including texture coordinates) other than position are simply replicated from the incoming point center vertex to the generated point object (corner) vertices. However, both DX9 and OGL support "sprite points", where some/all texture coordinates are replaced with full-scale 2D texture coordinates.

A 32-bit **PointSprite TextureCoordinate Enable** bit mask controls whether the corresponding vertex attribute is to be replaced by a sprite point texture coordinate. The global (not per-attribute) **Point Sprite TextureCoordinate Origin** field controls how the point object vertex (top/bottom, left/right) texture coordinates are generated:

UPPERLEFT	Left	Right
Top	(0,0,0,1)	(1,0,0,1)
Bottom	(0,1,0,1)	(1,1,0,1)

LOWERLEFT	Left	Right
Top	(0,1,0,1)	(1,1,0,1)
Bottom	(0,0,0,1)	(1,0,0,1)

Project:	HSW
The state used by "setup backend" is defined by the following inline state packet.	



3DSTATE_SBE

Barycentric Attribute Interpolation

Given hardware clipper and setup, some of the previous flexibility in the algorithm used to interpolate attributes is no longer available. Hardware uses barycentric parameters to aid in attribute interpolation, and these parameters are computed in hardware per-pixel (or per-sample) and delivered in the thread payload to the pixel shader. Also delivered in the payload are a set of vertex deltas (a_0 , a_1 , and a_2) per channel of each attribute.

There are six different barycentric parameters that can be enabled for delivery in the pixel shader payload. These are enabled via the **Barycentric Interpolation Mode** bits in 3DSTATE_WM.

In the pixel shader kernel, the following computation is done for each attribute channel of each pixel/sample given the corresponding attribute channel $a_0/a_1/a_2$ and the pixel/sample's b_1/b_2 barycentric parameters, where A is the value of the attribute channel at that pixel/sample:

$$A = a_0 + (a_1 * b_1) + (a_2 * b_2)$$



Depth Offset

The state for depth offset in `3DSTATE_SF` controls the depth offset function. Since this function was previously contained in the Windower stage, refer to the *Depth Offset* section in the Windower chapter for more details on this function.



Other SF Functions

Statistics Gathering

The SF stage itself does not have any associated pipeline statistics; however, it counts the number of objects being output by the clipper on the clipper's behalf, since it is less feasible to have the CLIP unit figure out how many objects have been output by a clip thread. It is easy for the SF unit to count the number of objects it receives from the CLIP stage since it is decomposing the output primitive topologies into objects anyway.

If the **Statistics Enable** bit is set in SF_STATE, then SF will increment the CL_PRIMITIVES_COUNT Register (see Memory Interface Registers in Volume Ia, *GPU*) once for each object in each primitive topology it receives from the CLIP stage. This bit should always be set if clipping is enabled and pipeline statistics are desired.

Software should always clear the **Statistics Enable** bit in SF_STATE if the clipper is disabled since objects SF receives are not considered "primitives output by the clipper" unless the clipper is enabled. Note that the clipper can be disabled either using bypass mode via a PIPELINE_STATE_POINTERS command with **Clip Enable** clear or by setting **Clip Mode** in CLIP_STATE to CLIPMODE_ACCEPT_ALL.

Other SF Functions

Statistics Gathering

The SF stage itself does not have any associated pipeline statistics; however, it counts the number of objects being output by the clipper on the clipper's behalf, since it is less feasible to have the CLIP unit figure out how many objects have been output by a clip thread. It is easy for the SF unit to count the number of objects it receives from the CLIP stage since it is decomposing the output primitive topologies into objects anyway.

If the **Statistics Enable** bit is set in SF_STATE, then SF will increment the CL_PRIMITIVES_COUNT Register (see Memory Interface Registers in Volume Ia, *GPU*) once for each object in each primitive topology it receives from the CLIP stage. This bit should always be set if clipping is enabled and pipeline statistics are desired.

Software should always clear the **Statistics Enable** bit in SF_STATE if the clipper is disabled since objects SF receives are not considered "primitives output by the clipper" unless the clipper is enabled. Note that the clipper can be disabled either using bypass mode via a PIPELINE_STATE_POINTERS command with **Clip Enable** clear or by setting **Clip Mode** in CLIP_STATE to CLIPMODE_ACCEPT_ALL.



Windower (WM) Stage

Overview

As mentioned in the *SF Unit* chapter, the SF stage prepares an object for scan conversion by the Window/Masker (WM) unit. Refer to the *SF Unit* chapter for details on the screen-space geometry of objects to be rendered. The WM unit uses the parameters provided by the SF unit in the object-specific rasterization algorithms.

The WM stage of the 3D pipeline performs the following operations (at a high level)

- Pre-scan-conversion modification of some primitive attributes, including
 - Application of Depth Offset to the position Z attribute
- Scan-conversion of the various primitive types, including
 - 2D clipping to the scissor/draw rectangle intersection
- Spawning of Pixel Shader (PS) threads to process the pixels resulting from scan-conversion

The spawned Pixel Shader (PS) threads are responsible for the following (high-level) operations

- interpolation of vertex attributes (other than X,Y,Z) to the pixel location
- performing any "Pixel Shader" operations dictated by the API PS program
 - Using the Sampler shared function to sample data from "texture" surfaces
 - Using the DataPort to perform general memory I/O
- Submitting the shaded pixel results to the DataPort for any subsequent "blending" (aka Output Merger) operation and write to the RenderCache.

The WM unit keeps a scoreboard of pixels being processed in outstanding PS threads in order to guarantee in-order rasterization results. This allows the WM unit to overlap processing of several objects.

Inputs from SF to WM

The outputs from the SF stage to the WM stage are mostly comprised of implementation-specific information required for the rasterization of objects. The types of information is summarized below, but as the interface is not exposed to software a detailed discussion is not relevant to this specification.

- PrimType of the object
- VPIndex, RTAIndex associated with the object
- Handle of the Primitive URB Entry (PUE) that was written by the SF (Setup) thread. This handle will be passed to all WM (PS) threads spawned from the WM's rasterization process.
- Information regarding the X,Y extent of the object (e.g., bounding box, etc.)
- Edge or line interpolation information (e.g., edge equation coefficients, etc.)



- Information on where the WM is to start rasterization of the object
- Object orientation (front/back-facing)
- Last Pixel indication (for line drawing)

Windower Pipelined State

3DSTATE_WM

The following inline state packets define the state used by the windower stage for different generations.

[3DSTATE_WM](#)

Programming Note: WM Unit also receives 3DSTATE_WM_HZ_OP, 3DSTATE_RASTER, 3DSTATE_MULTISAMPLE, 3DSTATE_WM_CHROMAKEY, 3DSTATE_PS_BLEND, and 3DSTATE_PS_EXTRA.

3DSTATE_SAMPLE_MASK

The following inline state packets define the sample mask state used by the windower stage for different generations.

3DSTATE_SAMPLE_MASK

State	Stencil buffer Clear	Depth buffer clear	Depth Buffer Resolve Enable	Hierarchical Depth Buffer Resolve Enable	Project
-------	-------------------------	-----------------------	--------------------------------	---	---------

Rasterization

The WM unit uses the setup computations performed by the SF unit to rasterize objects into the corresponding set of pixels. Most of the controls regarding the screen-space geometry of rendered objects are programmed via the SF unit.

The rasterization process generates pixels in 2x2 groups of pixels called *subspans* (see *Pixels with a SubSpan* below) which, after being subjected to various inclusion/discard tests, are grouped and passed to spawned Pixel Shader (PS) threads for subsequent processing. Once these PS threads are spawned, the WM unit provides only bookkeeping functions on the pixels. Note that the WM unit can proceed on to rasterize subsequent objects while PS threads from previous objects are still executing.



Pixels with a SubSpan

Pixel 0	Pixel 1
Pixel 2	Pixel 3

B6850-01

Drawing Rectangle Clipping

The Drawing Rectangle defines the maximum extent of pixels which can be rendered. Portions of objects falling outside the Drawing Rectangle will be clipped (pixels discarded). Implementations will typically discard objects falling completely outside of the Drawing Rectangle as early in the pipeline as possible. There is no control to turn off Drawing Rectangle clipping – it is unconditional.

For the purposes of clipping, the Drawing Rectangle must itself be clipped to the destination buffer extents (The Drawing Rectangle Origin, used to offset relative X,Y coordinates earlier in the pipeline, is permitted to lie offscreen). The **Clipped Drawing Rectangle X,Y Min,Max** state variables (programmed via `3DSTATE_DRAWING_RECTANGLE` – See *SF Unit*) defines the intersection of the Drawing Rectangle and the Color Buffer. It is specified with non-negative integer pixel coordinates relative to the Destination Buffer upper-left origin.

Pixels with coordinates outside of the Drawing Rectangle cannot be rendered (i.e., the rectangle is inclusive). For example, to render to a full-screen 1280x1024 buffer, the following values would be required: $X_{min}=0$, $Y_{min}=0$, $X_{max}=1279$ and $Y_{max}=1023$.

For *full screen* rendering, the Drawing Rectangle coincides with the screen-sized buffer. For *front-buffer windowed* rendering it coincides with the destination *window*.

Line Rasterization

See *SF Unit* chapter for details on the screen-space geometry of the various line types.

Coverage Values for Anti-Aliased Lines

The WM unit is provided with both the **Line Anti-Aliasing Region Width** and **Line End Cap Anti-aliasing Region Width** state variables (in `WM_STATE`) in order to compute the coverage values for anti-aliased lines.

3DSTATE_AA_LINE_PARAMS

3DSTATE_AA_LINE_PARAMETERS



The slope and bias values should be computed to closely match the reference rasterizer results. Based on empirical data, the following recommendations are offered:

The final alpha for the center of the line needs to be 148 to match the reference rasterizer. In this case, the Lo to edge 0 and edge 3 will be the same. Since the alpha for each edge is multiplied together, we get:

$$\text{edge0alpha} * \text{edge1alpha} = 148/255 = 0.580392157$$

Since $\text{edge0alpha} = \text{edge3alpha}$ we get:

$$(\text{edge0alpha})^2 = 0.580392157$$

$$\text{edge0alpha} = \sqrt{0.580392157} = 0.761834731 \text{ at the center pixel}$$

$$\text{The desired alpha for pixel 1} = 54/255 = 0.211764706$$

$$\text{The slope is } (0.761834731 - 0.211764706) = 0.550070025$$

Since we are using 8 bit precision, the slope becomes

$$\text{AA Coverage [EndCap] Slope} = 0.55078125$$

The alpha value for Lo = 0 (second pixel from center) determines the bias term and is equal to

$$(0.211764706 - 0.550070025) = -0.338305319$$

With 8 bits of precision the programmed bias value

Line Stipple

Line stipple, controlled via the **Line Stipple Enable** state variable in WM_STATE, discards certain pixels that are produced by non-AA line rasterization.

The line stipple rule is specified via the following state variables programmed via 3DSTATE_LINE_STIPPLE: the 16-bit **Line Stipple Pattern** (p), **Line Stipple Repeat Count** I, and **Line Stipple Inverse Repeat Count**. Software must compute **Line Stipple Inverse Repeat Count** as $1.0f / \text{Line Stipple Repeat Count}$ and then converted from float to the required fixed point encoding (see 3STATE_LINE_STIPPLE).

The WM unit maintains an internal Line Stipple Counter state variable (s). The initial value of s is zero; s is incremented after production of each pixel of a line segment (pixels are produced in order, beginning at the starting point and working towards the ending point). S is reset to 0 whenever a new primitive is processed (unless the primitive type is LINESTRIP_CONT or LINESTRIP_CONT_BF), and before every line segment in a group of independent segments (LINELIST primitive).

During the rasterization of lines, the WM unit computes:

$$b = \lfloor s/r \rfloor \bmod 16,$$

A pixel is rendered if the bth bit of p is 1, otherwise it is discarded. The bits of p are numbered with 0 being the least significant and 15 being the most significant.

3DSTATE_LINE_STIPPLE



Polygon (Triangle and Rectangle) Rasterization

The rasterization of LINE, TRIANGLE, and RECTANGLE objects into pixels requires a *pixel sampling grid* to be defined. This grid is defined as an axis-aligned array of pixel sample points spaced exactly 1 pixel unit apart. If a sample point falls within one of these objects, the pixel associated with the sample point is considered *inside* the object, and information for that pixel is generated and passed down the pipeline.

For TRIANGLE and RECTANGLE objects, if a sample point intersects an edge of the object, the associated pixel is considered *inside* the object if the intersecting edge is a *left* or *top* edge (or, more exactly, the intersected edge is not a *right* or *bottom* edge). Note that *top* and *bottom* edges are by definition exactly horizontal. See *TRIANGLE and RECTANGLE Edge Types* below for the edge types for representative TRIANGLE and RECTANGLE objects (solid edges are inclusive, dashed edges are exclusive).

TRIANGLE and RECTANGLE Edge Types

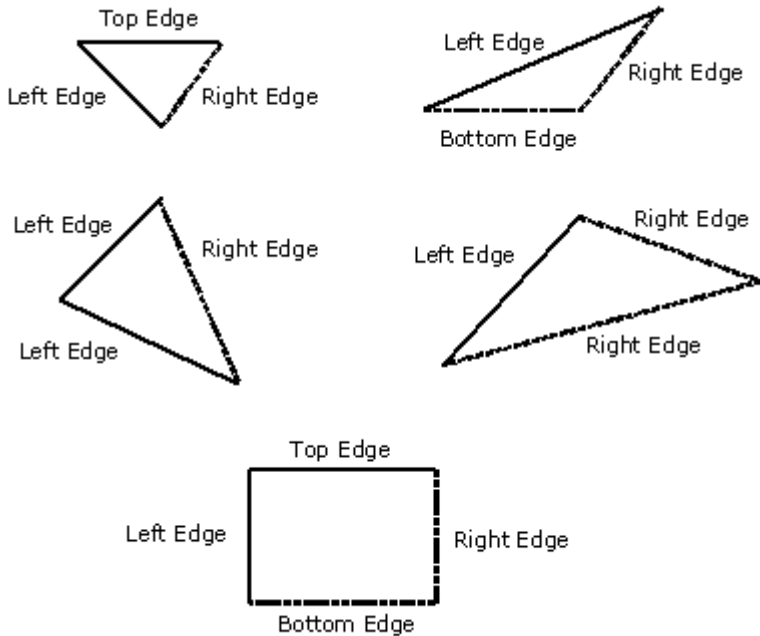

B.6851-01

Polygon Stipple

The *Polygon Stipple* function, controlled via the **Polygon Stipple Enable** state variable in WM_STATE, allows only selected pixels of a repeated 32x32 pixel pattern to be rendered. Polygon stipple is applied only to the following primitive types:

3DPRIM_POLYGON
3DPRIM_TRIFAN
3DPRIM_TRILIST
3DPRIM_TRISTRIP
3DPRIM_TRISTRIP_REVERSE



Note that the 3DPRIM_TRIFAN_NOSTIPPLE object is never subject to polygon stipple.

The stipple pattern is defined as a 32x32 bit pixel mask via the 3DSTATE_POLY_STIPPLE_PATTERN command. This is a non-pipelined command which incurs an implicit pipeline flush when executed.

The origin of the pattern is specified via **Polygon Stipple X,Y Offset** state variables programmed via the 3DSTATE_POLY_STIPPLE_OFFSET command. The offsets are pixel offsets from the Color Buffer origin to the upper left corner of the stipple pattern. This is a non-pipelined command which incurs an implicit pipeline flush when executed.

3DSTATE_POLY_STIPPLE_OFFSET

3DSTATE_POLY_STIPPLE_PATTERN

Multisampling

The multisampling function has two components:

- **Multisample Rasterization:** multisample rasterization occurs at a subpixel level, wherein each pixel consists of a number of "samples" at state-defined positions within the pixel footprint. Coverage of the primitive as well as color calculator operations (stencil test, depth test, color buffer blending, etc.) are done at the sample level. In addition the pixel shader itself can optionally run at the sample level depending on a separate state field.
- **Multisample Render Targets (MSRT):** The render targets, as well as the depth and stencil buffers, now have the ability to store per-sample values. When combined with multisample rasterization, color calculator operations such as stencil test, depth test, and color buffer blending are done with the destination surface containing potentially different values per sample.

3DSTATE_MULTISAMPLE

3DSTATE_RAST_MULTISAMPLE

Multisample ModesState

A number of state variables control the operation of the multisampling function. The following table indicates the states and their location. Refer to the state definition for more details.

State Element	Project	Source	Description
Multisample Rasterization Mode		3DSTATE_SF and 3DSTATE_WM	Controls whether rasterization of non-lines is performed on a pixel or sample basis (PIXEL vs. PATTERN), and whether multisample rasterization of lines is enabled (OFF vs. ON). The mode is controlled directly.
Multisample Dispatch		3DSTATE_WM	Controls whether the pixel shader is executed per pixel



State Element	Project	Source	Description
Mode			or per sample.
Number of Multisamples		3DSTATE_MULTISAMPLE and SURFACE_STATE	Indicates the number of samples per pixel contained on the surface. This field in 3DSTATE_MULTISAMPLE must match the corresponding field in SURFACE_STATE for each render target. The depth, hierarchical depth, and stencil buffers inherit this field from 3DSTATE_MULTISAMPLE.
Rast Number of Samples		3DSTATE_RAST_MULTISAMPLE::Number of Rasterization Multisamples	Indicates the number of samples per pixel using RTIR rather than MSAA.
RTIR Enabled		3DSTATE_SF::RT Independent Rasterization Enable == 1	Enable Render Target Independent Rasterization.
Pixel Location		3DSTATE_MULTISAMPLE	Indicates the subpixel location where values specified as "pixel" are sampled. This is either the upper left corner or the center.
MSAA Sample Offsets		3DSTATE_MULTISAMPLE	For each of the N samples, specifies the subpixel location of each sample.
RTIR Sample Offsets		3DSTATE_RAST_MULTISAMPLE	For each of the N samples, specifies the subpixel location of each sample.

Project:	
Definitions for lines terms used in Table 2 through Table 4:	
<ul style="list-style-type: none"> • Legacy Lines: Way of drawing lines that allows Diamond Lines (SF_STATE::Line Width == 0.0), Non-anti-aliased Wide Lines (SF_STATE::Line Width != 0.0), and Line Stippling (3DSTATE_WM::Line Stipple Enable == 1). • AA Lines: Way of drawing lines that allows Anti-aliased line. These are lines rendered as rectangles that are centered on, and aligned to, the line joining the endpoint vertices with coverage value (referred to as Anti-alias Alpha) computed per pixel. 	
Project	AA Line Support Requirement
HSW	3DSTATE_SF::Anti-aliasing Enable == 1

Project:	
-----------------	--

- **MSAA Lines:** Way of drawing lines that allows Multisample Anti-aliased lines. These are lines rendered as rectangles that are centered on, and aligned to, the line joining the endpoint vertices, but no Anti alias alpha coverage is computed.

Table 2: Type of Line Algorithm Given an Arrangement of State Variables

Multisample Rasterization Mode	Anti-Aliasing Enable	SF_STATE::Line Width	Line Algorithm
OFF_*	0	Non-Zero	Non-Anti-aliased Wide Lines
OFF_*	0	0.0	Diamond Lines
OFF_*	1	Non-Zero	See Note A below.
OFF_*	1	0.0	Diamond Lines
ON_*	*	*	MSAA Lines

Note A: Anti-Aliasing Details for Table 2

Project	Anti-Aliasing Details
HSW	Anti-Aliased Lines with Alpha Coverage

Table 3: Multisample Modes with RTIR Disabled

Number of Multisamples	MS RAST MODE	MS DISP MODE	HW Mode
NUMSAMPLES_1	OFF_PIXEL	PERSAMPLE	Legacy Non-MSAA Mode 1X rasterization, using Pixel Location Legacy lines or AA-line rasterization 1X PS, sample at Pixel Location 1X output merge, eval Depth at Pixel Location
	ON_PIXEL	PERSAMPLE	1X Multisampling Mode 1X rasterization, using Pixel Location MSAA lines only, using Pixel Location 1X PS, sample at Pixel Location 1X output merge, eval Depth at Pixel Location
	-	PERPIXEL	Treated the same as PERSAMPLE
	ON_PATTERN	-	Invalid



Project:			
	OFF_PATTERN	-	Invalid
n where n > NUMSAMPLES_1	OFF_PIXEL	PERPIXEL	MSRT Only, PerPixel PS 1X rasterization, using Pixel Location See Note B below. 1X PS, sample at Pixel Location 4X output merge, eval Depth at Pixel Location
		PERSAMPLE	MSRT Only, PerSample PS 1X rasterization, using Pixel Location See Note B below. nX PS, all samples at Pixel Location nX output merge, eval Depth at Pixel Location
	ON_PIXEL	PERPIXEL	Multibuffering MSAA, PerPixel PS 1X rasterization, using Pixel Location MSAA lines only 1X PS, sample at Pixel Location 4X output merge, eval Depth at Pixel Location
		PERSAMPLE	Multibuffering MSAA, PerSample PS 1X rasterization, using Pixel Location MSAA lines only nX PS, all samples at Pixel Location nX output merge, eval Depth at Pixel Location
	OFF_PATTERN	PERPIXEL	Mixed Mode, PerPixel PS See Note B below. Non-Lines: nX rasterization, using Sample Offsets 1X PS, sample at Pixel Location nX output merge, eval depth at Sample



Project:		
		Offsets
		PERSAMPLE Mixed Mode, PerSample PS See Note B below. Non-Lines: nX rasterization, using Sample Offsets nX PS, sample at Pixel Location or Sample Offsets nX output merge, eval depth at Sample Offsets
	ON_PATTERN	PERPIXEL Pattern MSAA, PerPixel PS nX rasterization, using Sample Offsets MSAA lines only 1X PS, sample at Pixel Location nX output merge, eval depth at Sample Offsets
		PERSAMPLE Pattern MSAA, PerSample PS nX rasterization, using Sample Offsets MSAA lines only nX PS, sample at Pixel Location or Sample Offsets nX output merge, eval depth at Sample Offsets

Note B: Line Details for Table 3 and Table 4

Project	Line Details
HSW	Legacy lines or AA-line rasterization. For PERPIXEL or PERSAMPLE in Table 3 use pixel location. For OFF_PATTERN in Table 4 use pixel location.

Table 4: Multisample Modes with RTIR Enabled

Rast Number of Samples	MS RAST MODE	HW Mode
NUMRASTSAMPLES_1	OFF_PIXEL	Legacy Non-MSAA Mode 1X rasterization, using Pixel Location



Project:		
		Legacy lines or AA-line rasterization 1X PS, sample at Pixel Location 1X output merge, eval Depth at Pixel Location
	ON_PIXEL	1X Multisampling Mode 1X rasterization, using Pixel Location MSAA lines only, using Pixel Location 1X PS, sample at Pixel Location 1X output merge, eval Depth at Pixel Location
	ON_PATTERN	Invalid
	OFF_PATTERN	Invalid
n where n > NUMRASTSAMPLES_1	OFF_PIXEL	Invalid
	ON_PIXEL	Invalid
	OFF_PATTERN	Mixed Mode, PerPixel PS See Note B above. Non-Lines: nX rasterization, using Sample Offsets 1X PS, sample at Pixel Location 1X output merge, eval depth at Pixel Location
	ON_PATTERN	Pattern RTIR, PerPixel PS nX rasterization, using Sample Offsets MSAA lines only 1X PS, sample at Pixel Location 1X output merge, eval Depth at Pixel Location
Note: Multisample Dispatch Mode is not taken into account in Table 4 given that with RTIR:		
Project	Details	
HSW	The value of PERSAMPLE for this state variable is invalid.	

Other WM Functions

The only other WM function is Statistics Gathering.



Statistics Gathering

If **Statistics Enable** is set in WM_STATE or 3DSTATE_WM, the Windower increments the PS_INVOCATIONS_COUNT register once for each unmasked pixel (or sample) that is *dispatched* to a Pixel Shader thread.

If **Early Depth Test Enable** is set it is possible for pixels or samples to be discarded before reaching the Pixel Shader due to failing the depth or stencil test. PS_INVOCATIONS_COUNT will still be incremented for these pixels or samples since the depth test occurs after the pixel shader from the point of view of SW.

Other WM Functions

The only other WM function is Statistics Gathering.

Statistics Gathering

If **Statistics Enable** is set in WM_STATE or 3DSTATE_WM, the Windower increments the PS_INVOCATIONS_COUNT register once for each unmasked pixel (or sample) that is *dispatched* to a Pixel Shader thread.

If **Early Depth Test Enable** is set it is possible for pixels or samples to be discarded before reaching the Pixel Shader due to failing the depth or stencil test. PS_INVOCATIONS_COUNT will still be incremented for these pixels or samples since the depth test occurs after the pixel shader from the point of view of SW.



Pixel

This section contains the following subsections:

- **Depth and Stencil**, which covers the Depth and Stencil test functions
- **Pixel Dispatch**, which covers pixel shader state, pixel grouping, multisampling effects on pixel shader dispatch, and pixel shader thread payload
- **Pixel Backend**, which covers backend processing



Early Depth/Stencil Processing

The Windower/IZ unit provides the Early Depth Test function, a major performance-optimization feature where an attempt is made to remove pixels that fail the Depth and Stencil Tests prior to pixel shading. This requires the WM unit to perform the interpolation of pixel (*source*) depth values, read the current (*destination*) depth values from the cached depth buffer, and perform the Depth and Stencil Tests. As the WM unit has per-pixel source and destination Z values, these values are passed in the PS thread payload, if required.

Depth Offset

Note: The depth offset function is contained in SF unit, thus the state to control it is also contained in SF unit.

There are occasions where the Z position of some objects need to be slightly offset to reduce artifacts due to coplanar or near-coplanar primitives. A typical example is drawing the edges of triangles as wireframes – the lines need to be drawn slightly closer to the viewer to ensure they will not be occluded by the underlying polygon. Another example is drawing objects on a wall – without a bias on the z positions, they might be fully or partially occluded by the wall.

The device supports *global* depth offset, applied only to triangles, that bases the offset on the object's z slope. Note that there is no clamping applied at this stage after the Z position is offset – clamping to [0,1] can be performed later after the Z position is interpolated to the pixel. This is preferable to clamping prior to interpolation, as the clamping would change the Z slope of the entire object.

The Global Depth Offset function is controlled by the **Global Depth Offset Enable** state variable in WM_STATE. Global Depth Offset is only applied to 3DOBJ_TRIANGLE objects.

When Global Depth Offset Enable is ENABLED, the pipeline will compute:

$\text{MaxDepthSlope} = \max(\text{abs}(dZ/dX), \text{abs}(dz/dy))$ // approximation of max depth slope for polygon

When UNORM Depth Buffer is at Output Merger (or no Depth Buffer):

$$\text{Bias} = \text{GlobalDepthOffsetConstant} * r + \text{GlobalDepthOffsetScale} * \text{MaxDepthSlope}$$

Where r is the minimum representable value > 0 in the depth buffer format, converted to float32 (note: If state bit **Legacy Global Depth Bias Enable** is set, the r term will be forced to 1.0)

When Floating Point Depth Buffer at Output Merger:

$$\text{Bias} = \text{GlobalDepthOffsetConstant} * 2^{(\text{exponent}(\text{max } z \text{ in primitive}) - r)} + \text{GlobalDepthOffsetScale} * \text{MaxDepthSlope}$$

Where r is the # of mantissa bits in the floating point representation (excluding the hidden bit), e.g. 23 for float32 (note: If state bit Legacy Global Depth Bias Enable is set, no scaling is applied to the GlobalDepthOffsetConstant).



Adding Bias to z:

```
if (GlobalDepthOffsetClamp > 0)
    Bias = min(DepthBiasClamp, Bias)
else if(GlobalDepthOffsetClamp < 0)
    Bias = max(DepthBiasClamp, Bias)
// else if GlobalDepthOffsetClamp == 0, no clamping occurs
z = z + Bias
```

Biassing is constant for a given primitive. The biasing formulas are performed with float32 arithmetic. Global Depth Bias is not applied to any point or line primitives.

Early Depth Test/Stencil Test/Write

When **Early Depth Test Enable** is ENABLED, the WM unit will attempt to discard depth-occluded pixels during scan conversion (before processing them in the Pixel Shader). Pixels are only discarded when the WM unit can ensure that they would have no impact to the ColorBuffer or DepthBuffer. This function is therefore only a performance feature.

Note: **Early Depth Test Enable** bit is no longer present. This function is always enabled.

If some pixels within a subspan are discarded, only the pixel mask is affected indicating that the discarded pixels are not active. If all pixels within a subspan are discarded, that subspan will not even be dispatched.

Software-Provided PS Kernel Info

For the WM unit to properly perform Early Depth Test and supply the proper information in the PS thread payload (and even determine if a PS thread needs to be dispatched), it requires information regarding the PS kernel operation. This information is provided by a number of state bits in WM_STATE, as summarized in the following table.

State Bit	Description
Pixel Shader Kill Pixel	This must be set when there is a chance that valid pixels passed to a PS thread may be discarded. This includes the discard of pixels by the PS thread resulting from a <i>killpixel</i> or <i>alphatest</i> function or as dictated by the results of the sampling of a <i>chroma-keyed</i> texture. The WM unit needs this information to prevent early depth/stencil writes for pixels which might be killed by the PS thread, etc. See WM_STATE/3DSTATE_WM for more information.
Pixel Shader Computed Depth	This must be set when the PS thread computes the <i>source</i> depth value (i.e., from the API POV, writes to the <i>oDepth</i> output). In this case the WM unit can't make any decisions based on the WM-interpolated depth value. See WM_STATE/3DSTATE_WM for more information.
Pixel Shader Uses Source	Must be set if the PS thread requires the WM-interpolated source depth value. This forces the source depth to be passed in the thread payload where otherwise the WM unit would not have



State Bit	Description
Depth	seen it as required. See WM_STATE/3DSTATE_WM for more information.

Hierarchical Depth Buffer

A hierarchical depth buffer is supported to reduce memory traffic due to depth buffer accesses. This buffer is supported only in Tile Y memory.

The **Surface Type**, **Height**, **Width**, **Depth**, **Minimum Array Element**, **Render Target View Extent**, and **Depth Coordinate Offset X/Y** of the hierarchical depth buffer are inherited from the depth buffer. The height and width of the hierarchical depth buffer that must be allocated are computed by the following formulas, where HZ is the hierarchical depth buffer and Z is the depth buffer. The Z_Height, Z_Width, and Z_Depth values given in these formulas are those present in 3DSTATE_DEPTH_BUFFER incremented by one.

Project:
The value of Z_Height and Z_Width must each be multiplied by 2 before being applied to the table below if Number of Multisamples is set to NUMSAMPLES_4. The value of Z_Height must be multiplied by 2 and Z_Width must be multiplied by 4 before being applied to the table below if Number of Multisamples is set to NUMSAMPLES_8.

Project:															
Since Hierarchical Depth Buffer supports multiple LODs. The HZ_height is different as shown in the table below:															
<table border="1"> <thead> <tr> <th>Surface Type</th> <th>HZ_Width (Bytes)</th> <th>HZ_Height (Rows)</th> </tr> </thead> <tbody> <tr> <td>SURFTYPE_1D</td> <td>ceiling(Z_Width / 16) * 16</td> <td>Ceiling ((Q_pitch * Z_depth/2) /8) * 8</td> </tr> <tr> <td>SURFTYPE_2D</td> <td>ceiling(Z_Width / 16) * 16</td> <td>Ceiling ((Q_pitch * Z_depth/2) /8) * 8</td> </tr> <tr> <td>SURFTYPE_3D</td> <td>ceiling(Z_Width / 16) * 16</td> <td>see below</td> </tr> <tr> <td>SURFTYPE_CUBE</td> <td>ceiling(Z_Width / 16) * 16</td> <td>Ceiling ((Q_pitch * Z_depth * 6/2) /8) * 8</td> </tr> </tbody> </table>	Surface Type	HZ_Width (Bytes)	HZ_Height (Rows)	SURFTYPE_1D	ceiling(Z_Width / 16) * 16	Ceiling ((Q_pitch * Z_depth/2) /8) * 8	SURFTYPE_2D	ceiling(Z_Width / 16) * 16	Ceiling ((Q_pitch * Z_depth/2) /8) * 8	SURFTYPE_3D	ceiling(Z_Width / 16) * 16	see below	SURFTYPE_CUBE	ceiling(Z_Width / 16) * 16	Ceiling ((Q_pitch * Z_depth * 6/2) /8) * 8
Surface Type	HZ_Width (Bytes)	HZ_Height (Rows)													
SURFTYPE_1D	ceiling(Z_Width / 16) * 16	Ceiling ((Q_pitch * Z_depth/2) /8) * 8													
SURFTYPE_2D	ceiling(Z_Width / 16) * 16	Ceiling ((Q_pitch * Z_depth/2) /8) * 8													
SURFTYPE_3D	ceiling(Z_Width / 16) * 16	see below													
SURFTYPE_CUBE	ceiling(Z_Width / 16) * 16	Ceiling ((Q_pitch * Z_depth * 6/2) /8) * 8													
Where, Qpitch is computed using vertical alignment j=8. Please refer to the GPU overview volume for Qpitch definition.															

The minimum HZ_Height required for a 3D surface must be computed based on hL parameters documented in the GPU Overview volume, and the maximum LOD m:

$$HZ_Height = \frac{1}{2} \left[\sum_{i=0}^m h_i * \max \left(1, \text{floor} \left(\frac{Z_Depth}{2^i} \right) \right) \right]$$



To compute the minimum QPitch for the HZ surface, the height of each LOD in pixels is determined using the equations for h_L in the GPU Overview volume, using a vertical alignment $j=8$. The following equation gives the minimum HZ_QPitch based on largest LOD m defined in the surface:

$$HZ_QPitch = h_0 + \max \left(h_1, \sum_{i=2}^m h_i \right)$$

If m is less than 2, treat all h_L with $L > m$ as zero and use the above equation.

The minimum HZ_Height required for a 3D surface must be computed based on h_L parameters documented in the GPU Overview volume, and the maximum LOD m :

$$HZ_Height = \frac{1}{2} \left[\sum_{i=0}^m h_i * \text{floor} \left(\frac{Z_Depth}{2^i} \right) \right]$$

The format of the data in the hierarchical depth buffer is not documented here, as this surface needs only to be allocated by software. Hardware will read and write this surface during operation and its contents are discarded once the last primitive is rendered that uses the hierarchical depth buffer.

The hierarchical depth buffer can be enabled whenever a depth buffer is defined, with its effect being invisible other than generally higher performance. The only exception is the hierarchical depth buffer must be disabled when using software tiled rendering.

If HiZ is enabled, you must initialize the clear value by either:

1. Perform a depth clear pass to initialize the clear value.
2. Send a 3dstate_clear_params packet with valid = 1.

Without one of these events, context switching will fail, as it will try to save off a clear value even though no valid clear value has been set. When context restore happens, HW will restore an uninitialized clear value.

Depth Buffer Clear

With the hierarchical depth buffer enabled, performance is generally improved by using the special clear mechanism described here to clear the hierarchical depth buffer and the depth buffer. This is enabled though the **Depth Buffer Clear** field in WM_STATE or 3DSTATE_WM or using the 3DSTATE_WM_HZ_OP. This bit can be used to clear the depth buffer in the following situations:

- Complete depth buffer clear.



- Partial depth buffer clear with the clear value the same as the one used on the previous clear.
- Partial depth buffer clear with the clear value different than the one used on the previous clear can use this mechanism if a depth buffer resolve is performed first.

The following is required when performing a depth buffer clear using any of the above clearing methods (WM_STATE, 3DSTATE_WM or 3DSTATE_WM_HZ_OP).

- The hierarchical depth buffer enable must be set in the 3DSTATE_DEPTH_BUFFER.
- The fields in 3DSTATE_CLEAR_PARAMS are set to indicate the source of the clear value and (if source is in this command) the clear value itself.
- The clear value must be between the min and max depth values (inclusive) defined in the CC_VIEWPORT. If the depth buffer format is D32_FLOAT, then NaN values are also allowed.
- The following alignment restrictions need to be met while doing the fast-clears.

Project	Alignment Restriction
HSW	If Number of Multisamples is NUMSAMPLES_1, the rectangle must be aligned to an 8x4 pixel block relative to the upper left corner of the depth buffer, and contain an integer number of these pixel blocks, and all 8x4 pixels must be lit.
HSW	If Number of Multisamples is NUMSAMPLES_2, the rectangle must be aligned to a 4x4 pixel block (8x4 sample block) relative to the upper left corner of the depth buffer, and contain an integer number of these pixel blocks, and all samples of the 4x4 pixels must be lit.
HSW	If Number of Multisamples is NUMSAMPLES_4, the rectangle must be aligned to a 4x2 pixel block (8x4 sample block) relative to the upper left corner of the depth buffer, and contain an integer number of these pixel blocks, and all samples of the 4x2 pixels must be lit.
HSW	If Number of Multisamples is NUMSAMPLES_8, the rectangle must be aligned to a 2x2 pixel block (8x4 sample block) relative to the upper left corner of the depth buffer, and contain an integer number of these pixel blocks, and all samples of the 2x2 pixels must be lit.

The following is required when performing a depth buffer clear with using the WM_STATE or 3DSTATE_WM:

- If other rendering operations have preceded this clear, a PIPE_CONTROL with depth cache flush enabled, Depth Stall bit enabled must be issued before the rectangle primitive used for the depth buffer clear operation.
- **Depth Test Enable** must be disabled and **Depth Buffer Write Enable** must be enabled (if depth is being cleared).
- Stencil buffer clear can be performed at the same time by enabling Stencil Buffer Write Enable. Stencil Test Enable must be enabled and Stencil Pass Depth Pass Op set to REPLACE, and the clear value that is placed in the stencil buffer is the **Stencil Reference Value** from COLOR_CALC_STATE.
- Note also that stencil buffer clear can be performed without depth buffer clear. For stencil only clear, **Depth Test Enable** and **Depth Buffer Write Enable** must be disabled.

In some cases **Depth Buffer Clear** cannot be enabled and the legacy method of clearing must be used:



- If the depth buffer format is D32_FLOAT_S8X24_UINT or D24_UNORM_S8_UINT.
- If stencil test is enabled but the separate stencil buffer is disabled.

Depth buffer clear pass using any of the methods (WM_STATE, 3DSTATE_WM or 3DSTATE_WM_HZ_OP) must be followed by a PIPE_CONTROL command with DEPTH_STALL bit and Depth FLUSH bits "**set**" before starting to render. DepthStall and DepthFlush are not needed between consecutive depth clear passes nor is it required if the depth-clear pass was done with "full_surf_clear" bit set in the 3DSTATE_WM_HZ_OP.

Note: If using the optimized depth buffer clear, this pipecontrol should be done after the resetting of the clear/resolve bits in the 3DSTATE_WM_HZ_OP (step #8).

Depth Buffer Resolve

If the hierarchical depth buffer is enabled, the depth buffer may contain incorrect results after rendering is complete. If the depth buffer is retained and used for another purpose (i.e. as input to the sampling engine as a shadow map), it must first be "resolved". This is done by setting the **Depth Buffer Resolve Enable** field in WM_STATE or 3DSTATE_WM and rendering a full render target sized rectangle. Once this is complete, the depth buffer will contain the same contents as it would have had the rendering been performed with the hierarchical depth buffer disabled. In a typical usage model, depth buffer needs to be resolved after rendering on it and before using a depth buffer as a source for any consecutive operation. Depth buffer can be used as a source in three different cases: using it as a texture for the next rendering sequence, honoring a lock on the depth buffer to the host OR using the depth buffer as a blit source.

The following is required when performing a depth buffer resolve:

- A rectangle primitive of the same size as the previous depth buffer clear operation must be delivered, and depth buffer state cannot have changed since the previous depth buffer clear operation.
- **Depth Test Enable** must be enabled with the **Depth Test Function** set to NEVER. **Depth Buffer Write Enable** must be enabled. **Stencil Test Enable** and **Stencil Buffer Write Enable** must be disabled.
- **Pixel Shader Dispatch**, **Alpha Test**, **Pixel Shader Kill Pixel** and **Pixel Shader Computed Depth** must all be disabled.

Hierarchical Depth Buffer Resolve

If the hierarchical depth buffer is enabled, the hierarchical depth buffer may contain incorrect results if the depth buffer is written to outside of the 3D rendering operation. If this occurs, the hierarchical depth buffer must be "resolved" to avoid incorrect device behavior. This is done by setting the Hierarchical Depth Buffer Resolve Enable field in WM_STATE or 3DSTATE_WM and rendering a full render target sized rectangle. Once this is complete, the hierarchical depth buffer will contain contents such that rendering



will give the same results as it would have had the rendering been performed with the hierarchical depth buffer disabled.

The following is required when performing a hierarchical depth buffer resolve:

- A rectangle primitive covering the full render target must be delivered.
- **Depth Test Enable** must be disabled. **Depth Buffer Write Enable** must be enabled. **Stencil Test Enable** and **Stencil Buffer Write Enable** must be disabled.
- **Pixel Shader Dispatch**, **Alpha Test**, **Pixel Shader Kill Pixel**, and **Pixel Shader Computed Depth** must all be disabled.

Separate Stencil Buffer

The following tables describe the separate stencil buffer for different generations.

Project:
<p>The separate stencil buffer is always enabled, thus the field in 3DSTATE_DEPTH_BUFFER to explicitly enable the separate stencil buffer has been removed. Surface formats with interleaved depth and stencil are no longer supported.</p> <p>The stencil buffer has a format of R8_UNIT, and shares Surface Type, Height, Width, and Depth, Minimum Array Element, Render Target View Extent, Depth Coordinate Offset X/Y, LOD, and Depth Buffer Object Control State fields of the depth buffer.</p>

DepthStencil Buffer State

This section contains the state registers for the Depth/Stencil Buffers.

3DSTATE_DEPTH_BUFFER

3DSTATE_STENCIL_BUFFER

3DSTATE_HIER_DEPTH_BUFFER

3DSTATE_CLEAR_PARAMS



Pixel Shader Thread Generation

After a group of object fragments have been rasterized, the Pixel Shader (PSD) function is invoked to further compute output information and cause results to be written to output surfaces (like color, depth, stencil, UAVs etc). Fragments can be P or S.

For each fragment, the Pixel Shader calculates the values of the various vertex attributes that are to be interpolated across the object using the interpolation coefficients. It then executes an API-supplied Pixel Shader Program. Instructions in this program permit the accessing of texture map data, where Texture Samplers are employed to sample and filter texture maps (see the Shared Functions chapter). Arithmetic operations can be performed on the texture data, input fragment information, and Pixel Shader Constants to compute the resultant fragment's output. The Pixel Shader program also allows the pixel to be discarded from further processing.

3DSTATE_PS

This command is used to set state used by the pixel shader dispatch stage.

3DSTATE_PS

3DSTATE_CONSTANT_PS

3DSTATE_BINDING_TABLE_POINTERS_PS

3DSTATE_PUSH_CONSTANT_ALLOC_PS

3DSTATE_SAMPLER_STATE_POINTERS_PS

Pixel Grouping (Dispatch Size) Control

The WM unit can pass a grouping of 2 subspans (8 pixels), 4 subspans (16 pixels), or 8 subspans (32 pixels) to a Pixel Shader thread. Software should take into account the following considerations when determining which groupings to support/enable during operation. This determination involves a tradeoff of these likely conflicting issues. Note that the size of the dispatch has significant impact on the kernel program. (It is certainly not transparent to the kernel.) Also note that there is no implied spatial relationship between the subspans passed to a PS thread, other than the fact that they come from the same object.

- **Thread Efficiency:** In general, there is some amount of overhead involved with PS thread dispatch, and if this can be amortized over a larger number of pixels, efficiency will likely increase. This is especially true for very short PS kernels, as may be used for desktop composition, etc.
- **GRF Consumption:** Processing more pixels per thread requires a larger thread payload and likely more temporary register usage, both of which translate into a requirement for a larger GRF register allocation for the threads. This increased GRF usage could lead to increased use of scratch space (for spill/fill, etc.) and possibly less efficient use of the EUs (as it would be less likely to find an EU with enough free physical GRF registers to service the thread).
- **Object Size:** If the number of very small objects (e.g., covering 2 subspans or fewer) is expected to comprise a significant portion of the workload, supporting the 8-pixel dispatch mode may be



advantageous. Otherwise there could be a large number of 16-pixel dispatches with only 1 or 2 valid subspans, resulting in low efficiency for those threads.

- **Intangibles:** Kernel footprint & Instruction Cache impact; Complexity;

The groupings of subspans that the WM unit is allowed to include in a PS thread payload is controlled by the **32,16,8 Pixel Dispatch Enable** state variables programmed in WM_STATE. Using these state variables, the WM unit attempts to dispatch the largest allowed grouping of subspans. The following table lists the possible combinations of these state variables.

Please note that, the valid column in the table indicates which products supports the combination dispatch. Combinations that are not listed in the table are not available on any product.

The letter codes A, B, D, and E used in the Variable Pixel Dispatch table below are valid for all projects with some specific mode restrictions for specific projects for B, D, and E as indicated in the next few tables.

D is like B with an added general restriction, that it cannot be used in non-1x PERSAMPLE mode.

Project:	HSW
E cannot be used in PERSAMPLE mode with number of multisamples >= 2.	

Variable Pixel Dispatch

Contiguous 64 Pixel Dispatch Enable	Contiguous 32 Pixel Dispatch Enable	32 Pixel Dispatch Enable	16 Pixel Dispatch Enable	8 Pixel Dispatch Enable	Valid	IP for n- pixel Contiguous Dispatch		IP for n-pixel Dispatch (KSP offsets are in 128-bit instruction units)		
						n=64	n=32	n=32	n=16	n=8
0	0	0	0	1	A					KSP[0]
0	0	0	1	0	B				KSP[0]	
0	0	0	1	1	D				KSP[2]	KSP[0]
0	0	1	0	0	B			KSP[0]		
0	0	1	1	0	E			KSP[1]	KSP[2]	
0	0	1	1	1	D			KSP[1]	KSP[2]	KSP[0]
0	1	1	1	0	D		KSP[2]	KSP[1]	KSP[0]	
1	0	1	1	0	D	KSP[2]		KSP[1]	KSP[0]	

Each of the three KSP values is separately specified. In addition, each kernel has a separately-specified GRF register count.



Depending on the subspan grouping selected, the WM unit will modify the starting PS Instruction Pointer (derived from the Kernel Start Pointer in WM_STATE) as a means to inform the PS kernel of the number of subspans included in the payload. The modified IP is a function of the enabled modes and the dispatch size, as shown in the table below.

The driver must ensure that the PS kernel begins with a corresponding jump table to properly handle the number of subspans dispatched. The WM unit will "OR" in the two LSBs of the Kernel Pointer (bits 5:4) to create an instruction level address. (Note that the pointer from WM_STATE is 64-byte aligned which corresponds to four 128-bit instructions.)

If only one dispatch mode is enabled, the Jitter should not include any jump table entries at the beginning of the PS kernel. If multiple dispatch modes are enabled, a two entry jump table should always be inserted, regardless of which modes are enabled (jump table entry for 8 pixel dispatch, followed by jump table entry for 32 pixel dispatch).

Note that for SIMD32 dispatch, pixel shader dispatch function increments GRF Start Register for URB Data state by 2 to account for the additional SIMD16 payload. The Pixel Shader kernel needs to comprehend this modification for SIMD32.

```
if ( 32PixelDispatchEnable && n > 7 )
    Dispatch 32 Pixels
else if ( 16PixelDispatchEnable && ( n > 2 || ! 8PixelDispatchEnable ) )
    Dispatch 16 Pixels
else
    Dispatch 8 Pixels
end if
```

Contiguous Dispatch Modes

There are three cases to consider depending on which dispatch modes are enabled based on the legal combinations in the table above:

- **Only normal dispatch modes are enabled.** This is the normal operating mode in which all features are supported.
- **Only contiguous dispatch modes are enabled.** In this case, software must ensure that the fast composite restrictions are met.
- **Both normal and contiguous dispatch modes are enabled.** In this case, a combination of software and the setup kernel must check all of the restrictions required by the contiguous dispatch pixel shader code. The result of the check in the setup kernel is indicated in the message descriptor of the URB write message. The windower then chooses a dispatch mode from either the normal category or the contiguous category depending on whether the restriction check fails or passes, respectively.

If both the 32- and 64-pixel contiguous dispatch modes are enabled together, the windower chooses which one to use based on whether at least one pixel from the upper and lower 8x4 halves of the 8x8 block is active. If one half has no pixel active, the half that does have pixels active is dispatched as a 32-pixel thread.



The following logic describes how the windower chooses the dispatch mode based on which modes are enabled:

d32 = normal 32-pixel dispatch mode enabled

d16 = normal 16-pixel dispatch mode enabled

d8 = normal 8-pixel dispatch mode enabled

c64 = contiguous 64-pixel dispatch mode enabled

c32 = contiguous 32-pixel dispatch mode enabled

ContiguousSelect = (c64 || c32) && [!(d32 || d16 || d8) || RestrictionCheckPass]

Table: For ContiguousSelect true:

contiguous area available	first priority	second priority
both superspan halves	c64	c32
one superspan half	c32	c64

Table: For ContiguousSelect false:

subspans available	first priority	second priority	third priority
s >= 4	d32	d16	d8
4 > s >= 2	d16	d8	d32
2 > s >= 1	d8	d16	d32

Multisampling Effects on Pixel Shader Dispatch

The pixel shader payloads are defined in terms of subspans and pixels. The slots in the pixel shader thread previously mapped 1:1 with pixels. With multisampling, a slot could contain a pixel or may just contain a single sample, depending on the mode. Payload definitions now refer to *slot* to make the definition independent of multisampling mode.

MSDISPMODE_PERPIXEL Thread Dispatch

In PERPIXEL mode, the pixel shader kernel still works on 2/4/8 separate subspans, depending on dispatch mode. The fact that rasterization and the depth/stencil tests are being performed on a per-sample (not per-pixel) basis is transparent to the pixel shader kernel.

MSDISPMODE_PERSAMPLE Thread Dispatch

In PERSAMPLE mode, the pixel shader needs to operate on a sample vs. pixel basis (although this collapses in NUMSAMPLES_1 mode) Instead of processing strictly different subspans in parallel, the PS kernel processes different sample indices of one or more subspans in parallel For example, a SIMD16 dispatch in PERSAMPLE/NUMSAMPLES_4 mode would operate on a single subspan, with the usual 4 *Subspan0 pixel slots* used for the 4 *Sample0 locations of the (single) subspan* Subspan1 slots would be



used for the Sample1 locations, and so on This layout allows the pixel shader to compute derivatives/LOD based on deltas between corresponding sample locations in the subspan in the same fashion as LEGACY pixel shader execution, and as required by DX10.1.

Depending on the dispatch mode (8/16/32 pixels) and multisampling mode (1X/4X), there are different mappings of subspans/samples onto dispatches and slots-within-dispatch In some cases, more than one subspan may be included in a dispatch, while in other cases multiple dispatches are required to process all samples for a single subspan In the latter case, the **StartingSamplePairIndex** value is included in the payload header so the Render Target Write message will access the correct samples with each message.

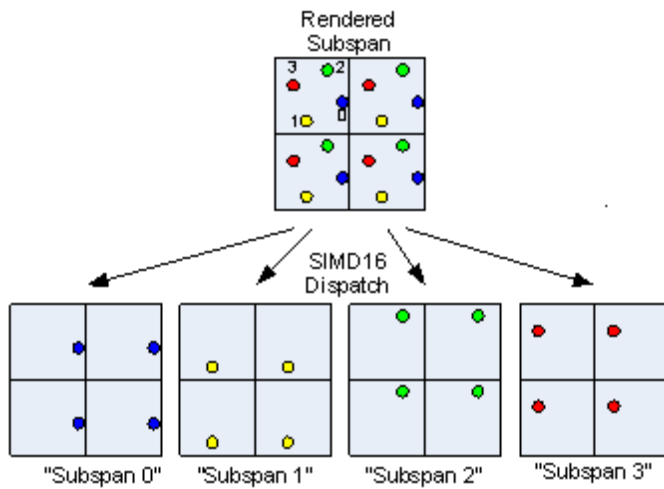

PERSAMPLE SIMD16 4X Dispatch

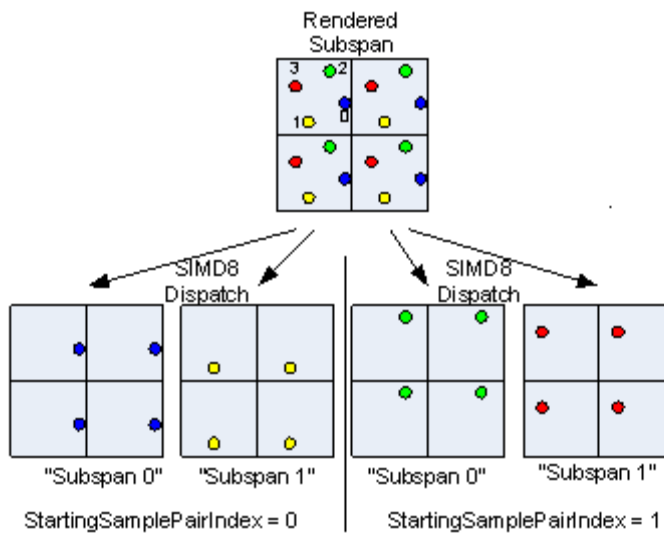



PERSAMPLE SIMD8 4X Dispatch

The following table provides the complete dispatch/slot mappings for all the MS/Dispatch combinations.

Dispatch Size	Num Samples	Slot Mapping (SSPI = Starting Sample Pair Index)
SIMD32	1X	Slot[3:0] = Subspan[0].Pixel[3:0].Sample[0] Slot[7:4] = Subspan[1].Pixel[3:0].Sample[0] Slot[11:8] = Subspan[2].Pixel[3:0].Sample[0] Slot[15:12] = Subspan[3].Pixel[3:0].Sample[0] Slot[19:16] = Subspan[4].Pixel[3:0].Sample[0] Slot[23:20] = Subspan[5].Pixel[3:0].Sample[0] Slot[27:24] = Subspan[6].Pixel[3:0].Sample[0] Slot[31:28] = Subspan[7].Pixel[3:0].Sample[0]
	2X	Slot[3:0] = Subspan[0].Pixel[3:0].Sample[0] Slot[7:4] = Subspan[0].Pixel[3:0].Sample[1] Slot[11:8] = Subspan[1].Pixel[3:0].Sample[0] Slot[15:12] = Subspan[1].Pixel[3:0].Sample[1] Slot[19:16] = Subspan[2].Pixel[3:0].Sample[0] Slot[23:20] = Subspan[2].Pixel[3:0].Sample[1] Slot[27:24] = Subspan[3].Pixel[3:0].Sample[0] Slot[31:28] = Subspan[3].Pixel[3:0].Sample[1]
	4X	Slot[3:0] = Subspan[0].Pixel[3:0].Sample[0] Slot[7:4] = Subspan[0].Pixel[3:0].Sample[1] Slot[11:8] = Subspan[0].Pixel[3:0].Sample[2] Slot[15:12] = Subspan[0].Pixel[3:0].Sample[3] Slot[19:16] = Subspan[1].Pixel[3:0].Sample[0] Slot[23:20] = Subspan[1].Pixel[3:0].Sample[1] Slot[27:24] = Subspan[1].Pixel[3:0].Sample[2] Slot[31:28] = Subspan[1].Pixel[3:0].Sample[3]
	8X	Slot[3:0] = Subspan[0].Pixel[3:0].Sample[0] Slot[7:4] = Subspan[0].Pixel[3:0].Sample[1] Slot[11:8] = Subspan[0].Pixel[3:0].Sample[2]



Dispatch Size	Num Samples	Slot Mapping (SSPI = Starting Sample Pair Index)
		Slot[15:12] = Subspan[0].Pixel[3:0].Sample[3] Slot[19:16] = Subspan[0].Pixel[3:0].Sample[4] Slot[23:20] = Subspan[0].Pixel[3:0].Sample[5] Slot[27:24] = Subspan[0].Pixel[3:0].Sample[6] Slot[31:28] = Subspan[0].Pixel[3:0].Sample[7]
SIMD16	1X	Slot[3:0] = Subspan[0].Pixel[3:0].Sample[0] Slot[7:4] = Subspan[1].Pixel[3:0].Sample[0] Slot[11:8] = Subspan[2].Pixel[3:0].Sample[0] Slot[15:12] = Subspan[3].Pixel[3:0].Sample[0]
	2X	Slot[3:0] = Subspan[0].Pixel[3:0].Sample[0] Slot[7:4] = Subspan[0].Pixel[3:0].Sample[1] Slot[11:8] = Subspan[1].Pixel[3:0].Sample[0] Slot[15:12] = Subspan[1].Pixel[3:0].Sample[1]
	4X	Slot[3:0] = Subspan[0].Pixel[3:0].Sample[0] Slot[7:4] = Subspan[0].Pixel[3:0].Sample[1] Slot[11:8] = Subspan[0].Pixel[3:0].Sample[2] Slot[15:12] = Subspan[0].Pixel[3:0].Sample[3]
	8X	Dispatch[i]: (i=0, 2) SSPI = i Slot[3:0] = Subspan[0].Pixel[3:0].Sample[SSPI*2+0] Slot[7:4] = Subspan[0].Pixel[3:0].Sample[SSPI*2+1] Slot[11:8] = Subspan[0].Pixel[3:0].Sample[SSPI*2+2] Slot[15:12] = Subspan[0].Pixel[3:0].Sample[SSPI*2+3]
SIMD8	1X	Slot[3:0] = Subspan[0].Pixel[3:0].Sample[0] Slot[7:4] = Subspan[1].Pixel[3:0].Sample[0]
	2X	Slot[3:0] = Subspan[0].Pixel[3:0].Sample[0] Slot[7:4] = Subspan[0].Pixel[3:0].Sample[1]
	4X	Dispatch[i]: (i=0..1) SSPI = i



Dispatch Size	Num Samples	Slot Mapping (SSPI = Starting Sample Pair Index)
		Slot[3:0] = Subspan[0].Pixel[3:0].Sample[SSPI*2+0] Slot[7:4] = Subspan[0].Pixel[3:0].Sample[SSPI*2+1]
	8X	Dispatch[i]: (i=0, 1, 2, 3) SSPI = i Slot[3:0] = Subspan[0].Pixel[3:0].Sample[SSPI*2+0] Slot[7:4] = Subspan[0].Pixel[3:0].Sample[SSPI*2+1]

PS Thread Payload for Normal Dispatch

The following table lists all possible contents included in a PS thread payload, in the order they are provided. Certain portions of the payload are optional, in which case the corresponding phase is skipped.

This payload does not apply to the contiguous dispatch modes. The payload for these modes is documented in the section titled *PS Thread Payload for Contiguous Dispatch*.

PS Thread Payload for Normal Dispatch

The following payload (UNRESOLVED CROSS REFERENCE, PS Thread Payload for Normal Dispatch) applies to . All registers are numbered starting at 0, but many registers are skipped depending on configuration. This causes all registers below to be renumbered to fill in the skipped locations. The only case where actual registers may be skipped is immediately before the constant data and again before the setup data.

PS Thread Payload for Normal Dispatch

DWord	Bits	Description	Project
R0.7	31		
	30:24	Reserved	
	23:0	Primitive Thread ID: This field contains the primitive thread count passed to the Windower from the Strips Fans Unit. Format: Reserved for HW Implementation Use.	
R0.6	31:24	Reserved	
	23:0	Thread ID: This field contains the thread count which is incremented by the Windower for every thread that is dispatched. Format: Reserved for HW Implementation Use.	
R0.5	31:10	Scratch Space Pointer: Specifies the 1K-byte aligned pointer to the scratch space available for this PS thread. This is specified as an offset to the General State Base Address .	



DWord	Bits	Description	Project
		Format = GeneralStateOffset[31:10]	
	9:8	Reserved	
	7:0	<p>FFTID: This ID is assigned by the WM unit and is an identifier for the thread. It is used to free up resources used by the thread upon thread completion.</p> <p>Format: Reserved for HW Implementation Use.</p>	
R0.4	31:5	<p>Binding Table Pointer: Specifies the 32-byte aligned pointer to the Binding Table. It is specified as an offset from the Surface State Base Address.</p> <p>Format = SurfaceStateOffset[31:5]</p>	
	4:0	Reserved	
R0.3	31:5	<p>Sampler State Pointer: Specifies the 32-byte aligned pointer to the Sampler State table. It is specified as an offset from the Dynamic State Base Address.</p> <p>Format = DynamicStateOffset[31:5]</p>	
	4	Reserved	
	3:0	<p>Per Thread Scratch Space: Specifies the amount of scratch space allowed to be used by this thread.</p> <p>Programming Notes: This amount is available to the kernel for information only. It will be passed verbatim (if not altered by the kernel) to the Data Port in any scratch space access messages, but the Data Port will ignore it.</p> <p>Format = U4</p> <p>Range = [0,11] indicating [1k bytes, 2M bytes] in powers of two</p>	
R0.2	31:0	Reserved: Delivered as zeros (reserved for message header fields).	
R0.1	31:6	<p>Color Calculator State Pointer: Specifies the 64-byte aligned pointer to the Color Calculator state (COLOR_CALC_STATE structure in memory). It is specified as an offset from the Dynamic State Base Address. This value is eventually passed to the ColorCalc function in the DataPort and is used to fetch the corresponding CC_STATE data.</p> <p>Format = DynamicStateOffset[31:5]</p>	
	5:0	Reserved	
R0.0	31	Reserved	
	30:27	<p>Viewport Index: Specifies the index of the viewport currently being used.</p> <p>Format = U4</p> <p>Range = [0,15]</p>	
	26:16	<p>Render Target Array Index: Specifies the array index to be used for the following surface types:</p> <p>SURFTYPE_1D: specifies the array index Range = [0,2047]</p> <p>SURFTYPE_2D: specifies the array index Range = [0,2047]</p> <p>SURFTYPE_3D: specifies the "r" coordinate Range = [0,2047]</p>	



DWord	Bits	Description	Project														
		<p>SURFTYPE_CUBE: specifies the face identifier Range = [0,5]</p> <table border="1"> <tr> <td></td> <td>Render Target Array Index</td> </tr> <tr> <td>+x</td> <td>0</td> </tr> <tr> <td>-x</td> <td>1</td> </tr> <tr> <td>+y</td> <td>2</td> </tr> <tr> <td>-y</td> <td>3</td> </tr> <tr> <td>+z</td> <td>4</td> </tr> <tr> <td>-z</td> <td>5</td> </tr> </table> <p>Format = U11</p>		Render Target Array Index	+x	0	-x	1	+y	2	-y	3	+z	4	-z	5	
	Render Target Array Index																
+x	0																
-x	1																
+y	2																
-y	3																
+z	4																
-z	5																
	15	<p>Front/Back Facing Polygon: Determines whether the polygon is front or back facing. Used by the render cache to determine which stencil test state to use.</p> <p>0: Front Facing 1: Back Facing</p>															
	14	Reserved															
	13	Source Depth to Render Target: Indicates that source depth will be sent to the render target.															
	12	oMask to Render Target: Indicates that oMask will be sent to the render target.															
	11:9	Reserved															
	8	Reserved for expansion of Starting Sample Pair Index .															
	7:6	<p>Starting Sample Pair Index: Indicates the index of the first sample pair of the dispatch.</p> <p>Format = U2 Range = [0,3]</p>															
	5	Reserved															



DWord	Bits	Description	Project
	4:0	<p>Primitive Topology Type: This field identifies the Primitive Topology Type associated with the primitive spawning this object. The WM unit does not modify this value (e.g., objects within POINTLIST topologies see POINTLIST).</p> <p>Format: (See 3DPRIMITIVE command in <i>3D Pipeline</i>.)</p>	
R1.7	31:16	<p>Pixel/Sample Mask (SubSpan[3:0]): Indicates which pixels within the four subspans are lit. If 32 pixel dispatch is enabled, this field contains the pixel mask for the first four subspans.</p> <p>Note: This is not a duplicate of the Dispatch Mask that is delivered to the thread. The dispatch mask has all pixels within a subspan as active if any of them are lit to enable LOD calculations to occur correctly.</p> <p>This field must not be modified by the Pixel Shader kernel.</p>	
	15:0	<p>Pixel/Sample Mask Copy (SubSpan[3:0]): This is a duplicate copy of the pixel mask. This copy can be modified as the pixel shader thread executes in order to turn off pixels based on kill instructions.</p>	
R1.6	31:0	Reserved	
R1.5	31:16	<p>Y3: Y coordinate (screen space) for upper-left pixel of subspan 3 (slot 12).</p> <p>Format = U16</p>	
	15:0	<p>X3: X coordinate (screen space) for upper-left pixel of subspan 3 (slot 12).</p> <p>Format = U16</p>	
R1.4	31:16	<p>Y2: Y coordinate (screen space) for upper-left pixel of subspan 2 (slot 8).</p> <p>Format = U16</p>	
	15:0	<p>X2: X coordinate (screen space) for upper-left pixel of subspan 2 (slot 8).</p> <p>Format = U16</p>	
R1.3	31:16	<p>Y1: Y coordinate (screen space) for upper-left pixel of subspan 1 (slot 4).</p> <p>Format = U16</p>	
	15:0	<p>X1: X coordinate (screen space) for upper-left pixel of subspan 1 (slot 4).</p> <p>Format = U16</p>	
R1.2	31:16	<p>Y0: Y coordinate (screen space) for upper-left pixel of subspan 0 (slot 0).</p> <p>Format = U16</p>	
	15:0	<p>X0: X coordinate (screen space) for upper-left pixel of subspan 0 (slot 0).</p> <p>Format = U16</p>	
R1.1	31:0	Reserved	



DWord	Bits	Description	Project
R1.0	31:20	Reserved	
	15:12	Slot 3 SampleID (if pixel or sample dispatch) Format = U4 1X MSAA range: [0] 2X MSAA range [0,1] 4X MSAA range [0..3] 8X MSAA range [0..7]	
	11:8	Slot 2 SampleID (if pixel or sample dispatch) Format = U4 1X MSAA range: [0] 2X MSAA range [0,1] 4X MSAA range [0..3] 8X MSAA range [0..7]	
	7:4	Slot 1 SampleID (if pixel or sample dispatch) Format = U4 1X MSAA range: [0] 2X MSAA range [0,1] 4X MSAA range [0..3] 8X MSAA range [0..7]	
	3:0	Slot 0 SampleID (if pixel or sample dispatch) Format = U4 1X MSAA range: [0] 2X MSAA range [0,1] 4X MSAA range [0..3] 8X MSAA range [0..7]	
		R2: Delivered only if this is a 32-pixel dispatch.	
R2.7	31:16	Pixel/Sample Mask (SubSpan[7:4]): Indicates which pixels within the upper four subspans are lit. This field is valid only when the 32 pixel dispatch state is enabled. This field must not be modified by the pixel shader thread. Note: This is not a duplicate of the dispatch mask that is delivered to the thread. The dispatch mask has all pixels within a subspan as active if any of them are lit to enable LOD calculations to occur correctly.	



DWord	Bits	Description	Project
		This field must not be modified by the Pixel Shader kernel.	
	15:0	Pixel/Sample Mask Copy (SubSpan[7:4]): This is a duplicate copy of pixel mask for the upper 16 pixels. This copy will be modified as the pixel shader thread executes to turn off pixels based on kill instructions.	
R2.6	31:0	Reserved	
R2.5	31:16	Y7: Y coordinate (screen space) for upper-left pixel of subspan 7 (slot 28) Format = U16	
	15:0	X7: X coordinate (screen space) for upper-left pixel of subspan 7 (slot 28) Format = U16	
R2.4	31:16	Y6	
	15:0	X6	
R2.3	31:16	Y5	
	15:0	X5	
R2.2	31:16	Y4	
	15:0	X4	
R2.1	31:0	Reserved	
R2.0	31:16	Reserved	
	15:12	Slot 7 SampleID Format = U4 1X MSAA range: [0] 2X MSAA range [0,1] 4X MSAA range [0..3] 8X MSAA range [0..7] 16X MSAA range [0..15]	
	11:8	Slot 6 SampleID Format = U4 1X MSAA range: [0] 2X MSAA range [0,1] 4X MSAA range [0..3] 8X MSAA range [0..7] 16X MSAA range [0..15]	
	7:4	Slot 5 SampleID Format = U4	



DWord	Bits	Description	Project
		1X MSAA range: [0] 2X MSAA range [0,1] 4X MSAA range [0..3] 8X MSAA range [0..7] 16X MSAA range [0..15]	
	3:0	Slot 4 SampleID Format = U4 1X MSAA range: [0] 2X MSAA range [0,1] 4X MSAA range [0..3] 8X MSAA range [0..7] 16X MSAA range [0..15]	
		R3-R26: Delivered only if the corresponding Barycentric Interpolation Mode bit is set. Register phases containing Slot 8-15 data are not delivered in <i>8-pixel dispatch</i> mode.	
R3.7	31:0	Perspective Pixel Location Barycentric[1] for Slot 7 This and the next register phase is only included if the corresponding enable bit in Barycentric Interpolation Mode is set. Format = IEEE_Float	
R3.6	31:0	Perspective Pixel Location Barycentric[1] for Slot 6	
R3.5	31:0	Perspective Pixel Location Barycentric[1] for Slot 5	
R3.4	31:0	Perspective Pixel Location Barycentric[1] for Slot 4	
R3.3	31:0	Perspective Pixel Location Barycentric[1] for Slot 3	
R3.2	31:0	Perspective Pixel Location Barycentric[1] for Slot 2	
R3.1	31:0	Perspective Pixel Location Barycentric[1] for Slot 1	
R3.0	31:0	Perspective Pixel Location Barycentric[1] for Slot 0	
R4		Perspective Pixel Location Barycentric[2] for Slots 7:0	
R5.7	31:0	Perspective Pixel Location Barycentric[1] for Slot 15	
R5.6	31:0	Perspective Pixel Location Barycentric[1] for Slot 14	
R5.5	31:0	Perspective Pixel Location Barycentric[1] for Slot 13	
R5.4	31:0	Perspective Pixel Location Barycentric[1] for Slot 12	
R5.3	31:0	Perspective Pixel Location Barycentric[1] for Slot 11	
R5.2	31:0	Perspective Pixel Location Barycentric[1] for Slot 10	
R5.1	31:0	Perspective Pixel Location Barycentric[1] for Slot 9	
R5.0	31:0	Perspective Pixel Location Barycentric[1] for Slot 8	



DWord	Bits	Description	Project
R6		Perspective Pixel Location Barycentric[2] for Slots 15:8	
R7:10		Perspective Centroid Barycentric	
R11:14		Perspective Sample Barycentric	
R15:18		Linear Pixel Location Barycentric	
R19:22		Linear Centroid Barycentric	
R23:26		Linear Sample Barycentric	
		R27: Delivered only if Pixel Shader Uses Source Depth is set.	
R27.7	31:0	Interpolated Depth for Slot 7 Format = IEEE_Float This and the next register phase is only included if Pixel Shader Uses Source Depth (WM_STATE) is set.	
R27.6	31:0	Interpolated Depth for Slot 6	
R27.5	31:0	Interpolated Depth for Slot 5	
R27.4	31:0	Interpolated Depth for Slot 4	
R27.3	31:0	Interpolated Depth for Slot 3	
R27.2	31:0	Interpolated Depth for Slot 2	
R27.1	31:0	Interpolated Depth for Slot 1	
R27.0	31:0	Interpolated Depth for Slot 0	
		R28: Delivered only if Pixel Shader Uses Source Depth is set and this is not an <i>8-pixel dispatch</i> .	
R28.7	31:0	Interpolated Depth for Slot 15	
R28.6	31:0	Interpolated Depth for Slot 14	
R28.5	31:0	Interpolated Depth for Slot 13	
R28.4	31:0	Interpolated Depth for Slot 12	
R28.3	31:0	Interpolated Depth for Slot 11	
R28.2	31:0	Interpolated Depth for Slot 10	
R28.1	31:0	Interpolated Depth for Slot 9	
R28.0	31:0	Interpolated Depth for Slot 8	
		R29: Delivered only if Pixel Shader Uses Source W is set.	
R29.7	31:0	Interpolated W for Slot 7 Format = IEEE_Float This and the next register phase are only included if Pixel Shader Uses Source W (WM_STATE) is set.	
R29.6	31:0	Interpolated W for Slot 6	
R29.5	31:0	Interpolated W for Slot 5	



DWord	Bits	Description	Project
R29.4	31:0	Interpolated W for Slot 4	
R29.3	31:0	Interpolated W for Slot 3	
R29.2	31:0	Interpolated W for Slot 2	
R29.1	31:0	Interpolated W for Slot 1	
R29.0	31:0	Interpolated W for Slot 0	
		R30: Delivered only if Pixel Shader Uses Source W is set and this is not an 8-pixel dispatch.	
R30.7	31:0	Interpolated W for Slot 15	
R30.6	31:0	Interpolated W for Slot 14	
R30.5	31:0	Interpolated W for Slot 13	
R30.4	31:0	Interpolated W for Slot 12	
R30.3	31:0	Interpolated W for Slot 11	
R30.2	31:0	Interpolated W for Slot 10	
R30.1	31:0	Interpolated W for Slot 9	
R30.0	31:0	Interpolated W for Slot 8	
		R31: Delivered only if Position XY Offset Select is either POSOFFSET_CENTROID or POSOFFSET_SAMPLE.	
R31.7	31:24	Position Offset Y for Slot 15 This field contains either the CENTROID or SAMPLE position offset for Y, depending on the state of Position XY Offset Select . Format = U4.4 Range = [0.0,1.0)	
	23:16	Position Offset X for Slot 15 This field contains either the CENTROID or SAMPLE position offset for X, depending on the state of Position XY Offset Select . Format = U4.4 Range = [0.0,1.0)	
	15:8	Position Offset Y for Slot 14	
	7:0	Position Offset X for Slot 14	
R31.6	31:24	Position Offset Y for Slot 13	
	23:16	Position Offset X for Slot 13	
	15:8	Position Offset Y for Slot 12	
	7:0	Position Offset X for Slot 12	
R31.5:4		Position Offset X/Y for Slot[11:8]	
R31.3:2		Position Offset X/Y for Slot[7:4]	
R31.1:0		Position Offset X/Y for Slot[3:0]	



DWord	Bits	Description	Project
		R32: Delivered only if Pixel Shader Uses Input Coverage Mask is set.	
R32.7	31:0	Input Coverage Mask for Slot 7 Format = U32 This and the next register phase is only included if Pixel Shader Uses Input Coverage Mask (3DSTATE_PS) is set. This field always encodes sample Coverage Mask.)
R32.6	31:0	Input Coverage Mask for Slot 6	
R32.5	31:0	Input Coverage Mask for Slot 5	
R32.4	31:0	Input Coverage Mask for Slot 4	
R32.3	31:0	Input Coverage Mask for Slot 3	
R32.2	31:0	Input Coverage Mask for Slot 2	
R32.1	31:0	Input Coverage Mask for Slot 1	
R32.0	31:0	Input Coverage Mask for Slot 0	
		R33: Delivered only if Pixel Shader Uses Input Coverage Mask is set and this is not an <i>8-pixel dispatch</i> .	
R33.7	31:0	Input Coverage Mask for Slot 15	
R33.6	31:0	Input Coverage Mask for Slot 14	
R33.5	31:0	Input Coverage Mask for Slot 13	
R33.4	31:0	Input Coverage Mask for Slot 12	
R33.3	31:0	Input Coverage Mask for Slot 11	
R33.2	31:0	Input Coverage Mask for Slot 10	
R33.1	31:0	Input Coverage Mask for Slot 9	
R33.0	31:0	Input Coverage Mask for Slot 8	
		R34-R57: Delivered only if the corresponding Barycentric Interpolation Mode bit is set and this is a <i>32-pixel dispatch</i> .	
R34.7	31:0	Perspective Pixel Location Barycentric[1] for Slot 23 This and the next register phase is only included if the corresponding enable bit in Barycentric Interpolation Mode is set. Format = IEEE_Float	
R34.6	31:0	Perspective Pixel Location Barycentric[1] for Slot 22	
R34.5	31:0	Perspective Pixel Location Barycentric[1] for Slot 21	
R34.4	31:0	Perspective Pixel Location Barycentric[1] for Slot 20	
R34.3	31:0	Perspective Pixel Location Barycentric[1] for Slot 19	
R34.2	31:0	Perspective Pixel Location Barycentric[1] for Slot 18	
R34.1	31:0	Perspective Pixel Location Barycentric[1] for Slot 17	



DWord	Bits	Description	Project
R34.0	31:0	Perspective Pixel Location Barycentric[1] for Slot 16	
R35		Perspective Pixel Location Barycentric[2] for Slots 23:16	
R36.7	31:0	Perspective Pixel Location Barycentric[1] for Slot 31	
R36.6	31:0	Perspective Pixel Location Barycentric[1] for Slot 30	
R36.5	31:0	Perspective Pixel Location Barycentric[1] for Slot 29	
R36.4	31:0	Perspective Pixel Location Barycentric[1] for Slot 28	
R36.3	31:0	Perspective Pixel Location Barycentric[1] for Slot 27	
R36.2	31:0	Perspective Pixel Location Barycentric[1] for Slot 26	
R36.1	31:0	Perspective Pixel Location Barycentric[1] for Slot 25	
R36.0	31:0	Perspective Pixel Location Barycentric[1] for Slot 24	
R37		Perspective Pixel Location Barycentric[2] for Slots 31:24	
R38:41		Perspective Centroid Barycentric	
R42:45		Perspective Sample Barycentric	
R46:49		Linear Pixel Location Barycentric	
R50:53		Linear Centroid Barycentric	
R54:57		Linear Sample Barycentric	
		R58-R59: Delivered only if Pixel Shader Uses Source Depth is set and this is a 32-pixel dispatch.	
R58.7	31:0	Interpolated Depth for Slot 23 Format = IEEE_Float This and the next register phase is only included if Pixel Shader Uses Source Depth (WM_STATE) bit is set.	
R58.6	31:0	Interpolated Depth for Slot 22	
R58.5	31:0	Interpolated Depth for Slot 21	
R58.4	31:0	Interpolated Depth for Slot 20	
R58.3	31:0	Interpolated Depth for Slot 19	
R58.2	31:0	Interpolated Depth for Slot 18	
R58.1	31:0	Interpolated Depth for Slot 17	
R58.0	31:0	Interpolated Depth for Slot 16	
R59.7	31:0	Interpolated Depth for Slot 31	
R59.6	31:0	Interpolated Depth for Slot 30	
R59.5	31:0	Interpolated Depth for Slot 29	
R59.4	31:0	Interpolated Depth for Slot 28	
R59.3	31:0	Interpolated Depth for Slot 27	
R59.2	31:0	Interpolated Depth for Slot 26	
R59.1	31:0	Interpolated Depth for Slot 25	
R59.0	31:0	Interpolated Depth for Slot 24	
		R60-R61: Delivered only if Pixel Shader Uses Source W is set and this is	



DWord	Bits	Description	Project
		a 32-pixel dispatch.	
R60.7	31:0	Interpolated W for Slot 23 Format = IEEE_Float This and the next register phase are only included if Pixel Shader Uses Source W (WM_STATE) bit is set.	
R60.6	31:0	Interpolated W for Slot 22	
R60.5	31:0	Interpolated W for Slot 21	
R60.4	31:0	Interpolated W for Slot 20	
R60.3	31:0	Interpolated W for Slot 19	
R60.2	31:0	Interpolated W for Slot 18	
R60.1	31:0	Interpolated W for Slot 17	
R60.0	31:0	Interpolated W for Slot 16	
R61.7	31:0	Interpolated W for Slot 31	
R61.6	31:0	Interpolated W for Slot 30	
R61.5	31:0	Interpolated W for Slot 29	
R61.4	31:0	Interpolated W for Slot 28	
R61.3	31:0	Interpolated W for Slot 27	
R61.2	31:0	Interpolated W for Slot 26	
R61.1	31:0	Interpolated W for Slot 25	
R61.0	31:0	Interpolated W for Slot 24	
		R62: Delivered only if Position XY Offset Select is either POSOFFSET_CENTROID or POSOFFSET_SAMPLE and this is a 32-pixel dispatch.	
R62.7	31:24	Position Offset Y for Slot 31 This field contains either the CENTROID or SAMPLE position offset for Y, depending on the state of Position XY Offset Select . Format = U4.4 Range = [0.0,1.0)	
	23:16	Position Offset X for Slot 31 This field contains either the CENTROID or SAMPLE position offset for X, depending on the state of Position XY Offset Select . Format = U4.4 Range = [0.0,1.0)	
	15:8	Position Offset Y for Slot 30	
	7:0	Position Offset X for Slot 30	
R62.6	31:24	Position Offset Y for Slot 29	
	23:16	Position Offset X for Slot 29	



DWord	Bits	Description	Project
	15:8	Position Offset Y for Slot 28	
	7:0	Position Offset X for Slot 28	
R62.5:4		Position Offset X/Y for Slot[27:24]	
R62.3:2		Position Offset X/Y for Slot[23:20]	
R62.1:0		Position Offset X/Y for Slot[19:16]	
		R63-R64: Delivered only if Pixel Shader Uses Input Coverage Mask is set and this is a <i>32-pixel dispatch</i> .	
R63.7	31:0	Input Coverage Mask for Slot 23 Format = U32 This and the next register phase are only included if Pixel Shader Uses Input Coverage Mask (3DSTATE_PS) is set.	
R63.6	31:0	Input Coverage Mask for Slot 22	
R63.5	31:0	Input Coverage Mask for Slot 21	
R63.4	31:0	Input Coverage Mask for Slot 20	
R63.3	31:0	Input Coverage Mask for Slot 19	
R63.2	31:0	Input Coverage Mask for Slot 18	
R63.1	31:0	Input Coverage Mask for Slot 17	
R63.0	31:0	Input Coverage Mask for Slot 16	
R64.7	31:0	Input Coverage Mask for Slot 31	
R64.6	31:0	Input Coverage Mask for Slot 30	
R64.5	31:0	Input Coverage Mask for Slot 29	
R64.4	31:0	Input Coverage Mask for Slot 28	
R64.3	31:0	Input Coverage Mask for Slot 27	
R64.2	31:0	Input Coverage Mask for Slot 26	
R64.1	31:0	Input Coverage Mask for Slot 25	
R64.0	31:0	Input Coverage Mask for Slot 24	
		R66: delivered only if Pixel Shader Requires Source Depth and/or W Attribute Vertex Deltas is set.	
R66.7	31:0	rhw_c0 – Co for 1/w plane Format = IEEE_Float	
R66.6	31:0	Reserved – MBZ	
R66.5	31:0	rhw_cx – Cx for 1/w plane Format = IEEE_Float	
R66.4	31:0	rhw_cy - Cy for 1/w plane Format = IEEE_Float	



DWord	Bits	Description	Project
R66.3	31:0	z_c0 – Co for z plane Format = IEEE_Float	
R66.2	31:0	Reserved – MBZ	
R66.1	31:0	z_cx – Cx for z plane Format = IEEE_Float	
R66.0	31:0	z_cy - Cy for z plane Format = IEEE_Float	
R67: delivered only if Pixel Shader Requires Perspective Bary Planes is set.			
R67.7	31:0	bary2_c0 – Co for bary2/w plane Format = IEEE_Float	
R67.6	31:0	Reserved – MBZ	
R67.5	31:0	bary2_cx – Cx for bary2/w plane Format = IEEE_Float	
R67.4	31:0	bary2_cy - Cy for bary2/w plane Format = IEEE_Float	
R67.3	31:0	bary1_c0 – Co for bary1/w plane Format = IEEE_Float	
R67.2	31:0	Reserved – MBZ	
R67.1	31:0	bary1_cx – Cx for bary1/w plane Format = IEEE_Float	
R67.0	31:0	bary1_cy - Cy for bary1/w plane Format = IEEE_Float	
R68: delivered only if Pixel Shader Requires Non-Perspective Bary Planes is set.			
R68.7	31:0	npc_bary2_c0 – Co for npc_bary2 plane Format = IEEE_Float	
R68.6	31:0	Reserved – MBZ	
R68.5	31:0	npc_bary2_cx – Cx for npc_bary2 plane Format = IEEE_Float	



DWord	Bits	Description	Project
R68.4	31:0	npc_bary2_cy - Cy for npc_bary2 plane Format = IEEE_Float	
R68.3	31:0	npc_bary1_c0 – Co for npc_bary1 plane Format = IEEE_Float	
R68.2	31:0	Reserved – MBZ	
R68.1	31:0	npc_bary1_cx – Cx for npc_bary1 plane Format = IEEE_Float	
R68.0	31:0	npc_bary1_cy - Cy for npc_bary1 plane Format = IEEE_Float	
R69: delivered only if Pixel Shader Requires sample offsets is set.			
R69.7	31:28	Reserved – MBZ	
	27:24	Sub-sample Y offset for sample 15 Format: U0.4 Subpixel Y offset of Sample 15 relative to the UL pixel origin Range: [0,0.9375]	
	23:20	Reserved – MBZ	
	19:16	Sub-sample Y offset for sample 14	
	15:12	Reserved – MBZ	
	11:8	Sub-sample Y offset for sample 13	
	7:4	Reserved – MBZ	
	3:0	Sub-sample Y offset for sample 12	
R69.6	31:28	Reserved – MBZ	
	27:24	Sub-sample Y offset for sample 11	
	23:20	Reserved – MBZ	
	19:16	Sub-sample Y offset for sample 10	
	15:12	Reserved – MBZ	
	11:8	Sub-sample Y offset for sample 9	
	7:4	Reserved – MBZ	
	3:0	Sub-sample Y offset for sample 8	
R69.5	31:28	Reserved – MBZ	
	27:24	Sub-sample Y offset for sample 7	
	23:20	Reserved – MBZ	
	19:16	Sub-sample Y offset for sample 6	
	15:12	Reserved – MBZ	



DWord	Bits	Description	Project
	11:8	Sub-sample Y offset for sample 5	
	7:4	Reserved – MBZ	
	3:0	Sub-sample Y offset for sample 4	
R69.4	31:28	Reserved – MBZ	
	27:24	Sub-sample Y offset for sample 3	
	23:20	Reserved – MBZ	
	19:16	Sub-sample Y offset for sample 2	
	15:12	Reserved – MBZ	
	11:8	Sub-sample Y offset for sample 1	
	7:4	Reserved – MBZ	
	3:0	Sub-sample Y offset for sample 0	
R69.3	31:28	Reserved – MBZ	
	27:24	Sub-sample X offset for sample 15 Format: U0.4 Subpixel X offset of Sample 15 relative to the UL pixel origin Range: [0,0.9375]	
	23:20	Reserved – MBZ	
	19:16	Sub-sample X offset for sample 14	
	15:12	Reserved – MBZ	
	11:8	Sub-sample X offset for sample 13	
	7:4	Reserved – MBZ	
	3:0	Sub-sample X offset for sample 12	
	R69.2	31:28	Reserved – MBZ
27:24		Sub-sample X offset for sample 11	
23:20		Reserved – MBZ	
19:16		Sub-sample X offset for sample 10	
15:12		Reserved – MBZ	
11:8		Sub-sample X offset for sample 9	
7:4		Reserved – MBZ	
	3:0	Sub-sample X offset for sample 8	
R69.1	31:28	Reserved – MBZ	
	27:24	Sub-sample X offset for sample 7	
	23:20	Reserved – MBZ	
	19:16	Sub-sample X offset for sample 6	
	15:12	Reserved – MBZ	
	11:8	Sub-sample X offset for sample 5	
	7:4	Reserved – MBZ	
	3:0	Sub-sample X offset for sample 4	



DWord	Bits	Description	Project
R69.0	31:28	Reserved – MBZ	
	27:24	Sub-sample X offset for sample 3	
	23:20	Reserved – MBZ	
	19:16	Sub-sample X offset for sample 2	
	15:12	Reserved – MBZ	
	11:8	Sub-sample X offset for sample 1	
	7:4	Reserved – MBZ	
	3:0	Sub-sample X offset for sample 0	
		<p>Optional Padding before the Start of Constant/Setup Data</p> <p>The locations between the end of the Optional Payload Header and the location programmed via Dispatch GRF Start Register for Constant/Setup Data are considered "padding" and Reserved (see below).</p>	
Optional, multiple of 8 DWs	31:0	Reserved	
		<p>The Dispatch GRF Start Register for Constant/Setup Data state variable in 3DSTATE_WM is used to define the starting location of the constant and setup data within the PS thread payload. This control is provided to allow this data to be located at a fixed location within thread payloads, regardless of the amount of data in the Optional Payload Header. This permits the kernel to use direct GRF addressing to access the constant/setup data, regardless of the optional parameters being passed (as these are determined on-the-fly by the WM unit).</p>	
		<p>Constant Data (optional):</p> <p>Some amount of constant data (possible none) can be extracted from the push constant buffer (PCB) and passed to the thread following the R0 Header. The amount of data provided is defined by the sum of the read lengths in the last 3DSTATE_CONSTANT_PS command (taking the buffer enables into account).</p> <p>The Constant Data arrives in a non-interleaved format.</p>	
Optional, multiple of 8 DWs	31:0	Constant Data	
		<p>Setup Data (Attribute Vertex Deltas)</p> <p>Output data from the SF stage is delivered in the PS thread payload. The amount of data is determined by the Number of Output Attributes field. Each register contains two channels of one attribute. Thus, the total number of registers sent is equal to 2 * Number of Output Attributes.</p>	
Rp.7	31:0	a0[0].y – a0 vertex data for Attribute0.y	
Rp.6	31:0	Reserved	
Rp.5	31:0	a2[0].y – a2-a0 vertex delta for Attribute0.y	



DWord	Bits	Description	Project
Rp.4	31:0	a1[0].y – a1-a0 vertex delta for Attribute0.y	
Rp.3	31:0	a0[0].x – a0 vertex data for Attribute0.x	
Rp.2	31:0	Reserved	
Rp.1	31:0	a2[0].x – a2-a0 vertex delta for Attribute0.x	
Rp.0	31:0	a1[0].x – a1-a0 vertex delta for Attribute0.x	
R(p+1).7	31:0	a0[0].w – a0 vertex data for Attribute0.w	
R(p+1).6	31:0	Reserved	
R(p+1).5	31:0	a2[0].w – a2-a0 vertex delta for Attribute0.w	
R(p+1).4	31:0	a1[0].w – a1-a0 vertex delta for Attribute0.w	
R(p+1).3	31:0	a0[0].z – a0 vertex data for Attribute0.z	
R(p+1).2	31:0	Reserved	
R(p+1).1	31:0	a2[0].z – a2-a0 vertex delta for Attribute0.z	
R(p+1).0	31:0	a1[0].z – a1-a0 vertex delta for Attribute0.z	
R(p+2*n)		xy Vertex Deltas for Attributes n See definition of Rp for format.	
R(p+2*n+1)		zw Vertex Deltas for Attribute n See definition of R(p+1) for format.	



Pixel Backend

This section contains the following subsections:

- Various Color Calculators
- MCS Buffer for Render Target(s)
- Render Target Fast Clear
- Render TargetResolve

Color Calculator (Output Merger)

Overview

Note: The Color Calculator logic resides in the Render Cache backing Data Port (DAP) shared function. It is described in this chapter as the Color Calc functions are naturally an extension of the 3D pipeline past the WM stage. See the DataPort chapter for details on the messages used by the Pixel Shader to invoke Color Calculator functionality.

The *Color Calculator* (referred to as "Output Merger in the DX Spec) function within the Data Port shared function completes the processing of rasterized pixels after the pixel color and depth have been computed by the Pixel Shader. This processing is initiated when the pixel shader thread sends a Render Target Write message (see *Shared Functions*) to the Render Cache. (Note that a single pixel shader thread may send multiple Render Target Write messages, with the result that multiple render targets get updated.) The pixel variables pass through a pipeline of fixed (yet programmable) functions, and the results are conditionally written into the appropriate buffers.



The word "pixel" used in this section is effectively replaced with the word "sample" if multisample rasterization is enabled.

Pipeline Stage	Description
Alpha Coverage	It generates coverage masks using AlphaToCoverage AND/OR AlphaToOne functions based on src0.alpha.
Alpha Test	Compare pixel alpha with reference alpha and conditionally discard pixel.
Stencil Test	Compare pixel stencil value with reference and forward result to Buffer Update stage.
Depth Test	Compare pix.Z with corresponding Z value in the Depth Buffer and forward result to Buffer Update stage.
Color Blending	Combine pixel color with corresponding color in color buffer according to programmable function.
Gamma Correction	Adjust pixel's color according to gamma function for SRGB destination surfaces.
Color Quantization	Convert "full precision" pixel color values to fixed precision of the color buffer format.
Logic Ops	Combine pixel color logically with existing color buffer color (mutually exclusive with Color Blending).
Buffer Update	Write final pixel values to color and depth buffers or discard pixel without update.

The following logic describes the high-level operation of the Pixel Processing pipeline:

```
PixelProcessing() {  
    AlphaCoverage()  
    AlphaTest()  
    DepthBufferCoordinateOffsetDisable  
    StencilTest()  
    DepthTest()  
    ColorBufferBlending()  
    GammaCorrection()  
    ColorQuantization()  
    LogicalOps()  
    BufferUpdate()  
}
```



Alpha Coverage

Alpha coverage logic is supported for DevSNB+ and can be controlled using three state variables:

- **AlphaToCoverage Enable**, when enabled Color Calculator modifies the sample mask. This function (along with AlphaToOne) come at the top of the pixel pipeline. The sample's Source0.Alpha value (possibly being replicated from the pixel's Source0.Alpha) is used to compute a (optionally dithered) 1/2/4-bit mask (depending on NumSamples).
- The **AlphaToCoverage Dither Enable** SV is used to control the dithering of the AlphaToCoverage mask. The bit corresponding to the sample# is then ANDed with the sample's incoming mask bits – allowing the sample to be masked off depending on alpha.
- **AlphaToOne Enable**, when enabled, Color Calculator must replace Source0.Alpha (if present) with 1.0f.
- If AlphaToCoverage is disabled, AlphaToCoverage Dither does not have any impact.

Project:	HSW
If Pixel Shader outputs oMask, AlphaToCoverage is disabled in hardware, regardless of the state setting for this feature.	

Notes:

- Src0.alpha needs to be first multiplied with AA alpha before applying AlphaToCoverage and AlphaToOne functions.
- An alpha value of NaN results in a no coverage (zero) mask.
- Alpha values from the pixel shader are treated as FLOAT32 format for computing the AlphaToCoverage Mask.

Alpha Test

The Alpha Test function can be used to discard pixels based on a comparison between the incoming pixel's alpha value and the **Alpha Test Reference** state variable in COLOR_CALC_STATE. This operation can be used to remove transparent or nearly-transparent pixels, though other uses for the alpha channel and alpha test are certainly possible.

This function is enabled by the **Alpha Test Enable** state variable in COLOR_CALC_STATE. If ENABLED, this function compares the incoming pixel's alpha value (*pixColor.Alpha*) and the reference alpha value specified by via the **Alpha Test Reference** state variable in COLOR_CALC_STATE. The comparison performed is specified by the **Alpha Test Function** state variable in COLOR_CALC_STATE.

The **Alpha Test Format** state variable is used to specify whether Alpha Test is performed using fixed-point (UNORM8) or FLOAT32 values. Accordingly, it determines whether the **Alpha Reference Value** is passed in a UNORM8 or FLOAT32 format. If UNORM8 is selected, the pixel's alpha value will be converted from floating-point to UNORM8 before the comparison.



Pixels that pass the Alpha Test proceed for further processing. Those that fail are discarded at this point in the pipeline.

If **Alpha Test Enable** is DISABLED, this pipeline stage has no effect.

The Alpha Test function is supported in conjunction with Multiple Render Targets (MRTs). If delivered in the incoming render target write message, source 0 alpha is used to perform the alpha test. If source 0 alpha is not delivered, the normal alpha value is used to perform the alpha test.

Depth Coordinate Offset

The Depth Coordinate Offset function applies a programmable constant offset to the RenderTarget X,Y screen space coordinates in order to generate DepthBuffer coordinates.

The function has been specifically added to allow the OpenGL driver to deal with a RenderTarget and DepthBuffer of differing sizes.

OpenGL defines a lower-left screen coordinate origin. This requires the driver to incorporate a *Y coordinate flipping* transformation into the viewport mapping function. The Y extent of the RT is used in this flipping transformation. If the DepthBuffer extent is different, the wrong pixel Y locations within the DepthBuffer will be accessed.

The least expensive solution is to provide a translation offset to be applied to the post-viewport-mapped DepthBuffer Y pixel coordinate, effectively allowing the alignment of the lower-left origins of the RT and DepthBuffer. [Note that the previous DBCOD feature performed an optional translation of post-viewport-mapping RT pixel (screen) coordinates to generate DepthBuffer pixel (window) coordinates. Specifically, the Draw Rect Origin X,Y state could be subtracted from the RT pixel coordinates.]

This function uses **Depth Coordinate Offset X,Y** state (signed 16-bit values in 3DSTATE_DEPTH_RECTANGLE) that is unconditionally added to the RT pixel coordinates to generate DepthBuffer pixel coordinates.

The previous DBCOB feature can be supported by having the driver program Depth Coordinate X,Y Offset to the two's complement of the the Draw Rect Origin. By programming Depth Coordinate X,Y Offset to zeros, the current *normal* operation (DBCOD disabled) can be achieved.

Programming Restrictions:

- Only simple 2D RTs are supported (no mipmaps).
- Software must ensure that the resultant DepthBuffer Coordinate X,Y values are non-negative.
- There are alignment restrictions – see 3DSTATE_DEPTH_BUFFER command.



Stencil Test

The Stencil Test function can be used to discard pixels based on a comparison between the [**Backface**] **Stencil Test Reference** state variable and the pixel's stencil value. This is a general purpose function used for such effects as shadow volumes, per-pixel clipping, etc. The result of this comparison is used in the Stencil Buffer Update function later in the pipeline.

This function is enabled by the **Stencil Test Enable** state variable. If ENABLED, the current stencil buffer value for this pixel is read.

Programming Note:

- If the Depth Buffer is either undefined or does not have a surface format of D32_FLOAT_S8X24_UINT or D24_UNORM_S8_UINT and separate stencil buffer is disabled, **Stencil Test Enable** must be DISABLED.

A 2nd set of the stencil test state variables is provided so that pixels from back-facing objects, assuming they are not culled, can have a stencil test performed on them separate from the test for normal front-facing objects. The separate stencil test for back-facing objects can be enabled via the **Double Sided Stencil Enable** state variable. Otherwise, non-culled back-facing objects will use the same test function, mask and reference value as front-facing objects. The 2nd stencil state for back-facing objects is most commonly used to improve the performance of rendering shadow volumes which require a different stencil buffer operation depending on whether pixels rendered are from a front-facing or back-facing object. The backface stencil state removes the requirement to render the shadow volumes in 2 passes or sort the objects into front-facing and back-facing lists.

The remainder of this subsection describes the function in term of [**Backface**] **<state variable name>**. The Backface set of state variables are only used if Double Sided Stencil Enable is ENABLED and the object is considered back-facing. Otherwise the normal (front-facing) state variables are used.

This function then compares the [**Backface**] **Stencil Test Reference** value and the pixel's stencil value value after logically ANDing both values by [**Backface**] **Stencil Test Mask**. The comparison performed is specified by the [**Backface**] **Stencil Test Function** state variable. The result of the comparison is passed down the pipeline for use in the Stencil Buffer Update function. The Stencil Test function does not in itself discard pixels.

If **Stencil Test Enable** is DISABLED, a result of *stencil test passed* is propagated down the pipeline.



Depth Test

The Depth Test function can be used to discard pixels based on a comparison between the incoming pixel's depth value and the current depth buffer value associated with the pixel. This function is typically used to perform the *Z Buffer* hidden surface removal. The result of this pipeline function is used in the Stencil Buffer Update function later in the pipeline.

This function is enabled by the **Depth Test Enable** state variable. If enabled, the pixel's (*source*) depth value is first computed. After computation the pixel's depth value is clamped to the range defined by **Minimum Depth** and **Maximum Depth** in the selected CC_VIEWPORT state. Then the current (*destination*) depth buffer value for this pixel is read.

This function then compares the source and destination depth values. The comparison performed is specified by the **Depth Test Function** state variable.

The result of the comparison is propagated down the pipeline for use in the subsequent Depth Buffer Update function. The Depth Test function does not in itself discard pixels.

If **Depth Test Enable** is DISABLED, a result of *depth test passed* is propagated down the pipeline.

Programming Note:

- Enabling the Depth Test function without defining a Depth Buffer is UNDEFINED.

Pre-Blend Color Clamping

Pre-Blend Color Clamping, controlled via **Pre-Blend Color Clamp Enable** OR **Pre-Blend Source Only Clamp Enable** and **Color Clamp Range** states in COLOR_CALC_STATE, is affected by the enabling of Color Buffer Blend as described below.

The following table summarizes the requirements involved with Pre-/Post-Blend Color Clamping.

Blending	RT Format	Pre-Blend Color Clamp	Post-Blend Color Clamp
Off	UNORM, UNORM_SRGB,YCRCB	Must be enabled with range = RT range or [0,1] (same function)	N/A, state ignored
	SNORM	Must be enabled with range = RT range or [-1,1] (same function)	N/A, state ignored
	FLOAT (except for R11G11B10_FLOAT)	Must be enabled (with any desired range)	N/A, state ignored
	R11G11B10_FLOAT	Must be enabled with either [0,1] or RT range	N/A, state ignored
	UINT, SINT	State ignored, implied clamp to RT range	N/A, state ignored
On (where	UNORM, UNORM_SRGB	Must be enabled with range = RT range or [0,1] (same	Must be enabled with range = RT range or [0,1] (same



Blending	RT Format	Pre-Blend Color Clamp	Post-Blend Color Clamp
permitted)		function)	function)
	SNORM	Must be enabled with range = RT range or [-1,1] (same function)	Must be enabled with range = RT range or [-1,1] (same function)
	FLOAT (except for R11G11B10_FLOAT)	Can be disabled or enabled (with any desired range)	Must be enabled (with any desired range)
	R11G11B10_FLOAT	Can be disabled or enabled (with any desired range)	Must be enabled with either [0,1] or RT range

Pre-Blend Color Clamping When Blending is Disabled

The clamping of source color components is controlled by **Pre-Blend Color Clamp Enable**. If ENABLED, all source color components are clamped to the range specified by **Color Clamp Range**. If DISABLED, no clamping is performed.

Programming Notes:

- Given the possibility of writing UNPREDICTABLE values to the Color Buffer, it is expected and highly recommended that, when blending is disabled, software set **Pre-Blend Color Clamp Enable** to ENABLED and select an appropriate **Color Clamp Range**.
- When using SINT or UINT rendertarget surface formats, **Blending must** be DISABLED. The **Pre-Blend Color Clamp Enable** and **Color Clamp Range** fields are ignored, and an implied clamp to the rendertarget surface format is performed.

Pre-Blend Color Clamping When Blending is Enabled

The clamping of source, destination and constant color components is controlled by **Pre-Blend Color Clamp Enable**. If ENABLED, all these color components are clamped to the range specified by **Color Clamp Range**. If DISABLED, no clamping is performed on these color components prior to blending.

Color Buffer Blending

The Color Buffer Blending function is used to combine one or two incoming *source* pixel color+alpha values with the *destination* color+alpha read from the corresponding location in a RenderTarget.

Blending is enabled on a global basis by the **Color Buffer Blend Enable** state variable (in COLOR_CALC_STATE). If DISABLED, Blending and Post-Blend Clamp functions are disabled for all RenderTargets, and the pixel values (possibly subject to Pre-Blend Clamp) are passed through unchanged.

The Color Buffer Blend Enable is in the per-render-target BLEND_STATE, and the field in SURFACE_STATE is no longer supported.

Programming Notes:



- Color Buffer Blending and Logic Ops must not be enabled simultaneously, or behavior is UNDEFINED.
- Dual source blending: The DataPort only supports dual source blending with a SIMD8-style message.
- Only certain surface formats support Color Buffer Blending. Refer to the Surface Format tables in *Sampling Engine*. Blending must be disabled on a RenderTarget if blending is not supported.

The incoming *source* pixel values are modulated by a selected *source* blend factor, and the possibly gamma-decorrected *destination* values are modulated by a *destination* blend factor. These terms are then combined with a *blend function*. In general:

$$\begin{aligned} \text{src_term} &= \text{src_blend_factor} * \text{src_color} \\ \text{dst_term} &= \text{dst_blend_factor} * \text{dst_color} \\ \text{color output} &= \text{blend_function}(\text{src_term}, \text{dst_term}) \end{aligned}$$

If there is no alpha value contained in the Color Buffer, a default value of 1.0 is used and, correspondingly, there is no alpha component computed by this function.

Dual Source Blending: When using *Dual Source* Render Target Write messages, the Source1 pixel color+alpha passed in the message can be selected as a src/dst blend factor. See [Color Buffer Blend Color Factors](#). In single-source mode, those blend factor selections are invalid. If SRC1 is included in a src/dst blend factor and a DualSource RT Write message is not used, results are UNDEFINED. (This reflects the same restriction in DX APIs, where undefined results are produced if *o1* is not written by a PS – there are no default values defined). If SRC1 is not included in a src/dst blend factor, dual source blending must be disabled.

The blending of the color and alpha components is controlled with two separate (color and alpha) sets of state variables. However, if the **Independent Alpha Blend Enable** state variable in COLOR_CALC_STATE is DISABLED, then the *color* (rather than *alpha*) set of state variables is used for both color and alpha. Note that this is the only use of the **Independent Alpha Blend Enable** state – it does not control whether Blending occurs, only how.

Per **Render Target Blend State:** Blend state is selected based on **Render Target Index** contained in the message header, and appropriate blend state is applied to Render Target Write messages.

The following table describes the color source and destination blend factors controlled by the **Source [Alpha] Blend Factor** and **Destination [Alpha] Blend Factor** state variables in COLOR_CALC_STATE. Note that the blend factors applied to the R,G,B channels are always controlled by the **Source/Destination Blend Factor**, while the blend factor applied to the alpha channel is controlled either by **Source/Destination Blend Factor** or **Source/Destination Alpha Blend Factor**.



Color Buffer Blend Color Factors

Blend Factor Selection	Blend Factor Applied for R,G,B,A channels (oN = output from PS to RT#N) (o1 = 2 nd output from PS in Dual-Source mode only) (rtN = destination color from RT#N) (CC = Constant Color)
BLENDFACTOR_ZERO	0.0, 0.0, 0.0, 0.0
BLENDFACTOR_ONE	1.0, 1.0, 1.0, 1.0
BLENDFACTOR_SRC_COLOR	oN.r, oN.g, oN.b, oN.a
BLENDFACTOR_INV_SRC_COLOR	1.0-oN.r, 1.0-oN.g, 1.0-oN.b, 1.0-oN.a
BLENDFACTOR_SRC_ALPHA	oN.a, oN.a, oN.a, oN.a
BLENDFACTOR_INV_SRC_ALPHA	1.0-oN.a, 1.0-oN.a, 1.0-oN.a, 1.0-oN.a
BLENDFACTOR_SRC1_COLOR	o1.r, o1.g, o1.b, o1.a
BLENDFACTOR_INV_SRC1_COLOR	1.0-o1.r, 1.0-o1.g, 1.0-o1.b, 1.0-o1.a
BLENDFACTOR_SRC1_ALPHA	o1.a, o1.a, o1.a, o1.a
BLENDFACTOR_INV_SRC1_ALPHA	1.0-o1.a, 1.0-o1.a, 1.0-o1.a, 1.0-o1.a
BLENDFACTOR_DST_COLOR	rtN.r, rtN.g, rtN.b, rtN.a
BLENDFACTOR_INV_DST_COLOR	1.0-rtN.r, 1.0-rtN.g, 1.0-rtN.b, 1.0-rtN.a
BLENDFACTOR_DST_ALPHA	rtN.a, rtN.a, rtN.a, rtN.a
BLENDFACTOR_INV_DST_ALPHA	1.0-rtN.a, 1.0-rtN.a, 1.0-rtN.a, 1.0-rtN.a
BLENDFACTOR_CONST_COLOR	CC.r, CC.g, CC.b, CC.a
BLENDFACTOR_INV_CONST_COLOR	1.0-CC.r, 1.0-CC.g, 1.0-CC.b, 1.0-CC.a
BLENDFACTOR_CONST_ALPHA	CC.a, CC.a, CC.a, CC.a
BLENDFACTOR_INV_CONST_ALPHA	1.0-CC.a, 1.0-CC.a, 1.0-CC.a, 1.0-CC.a
BLENDFACTOR_SRC_ALPHA_SATURATE	f,f,f,1.0 where $f = \min(1.0 - rtN.a, oN.a)$

The following table lists the supported blending operations defined by the **Color Blend Function** state variable and the **Alpha Blend Function** state variable (when in independent alpha blend mode).

Color Buffer Blend Functions

Blend Function	Operation (for each color component)
BLENDFUNCTION_ADD	$SrcColor * SrcFactor + DstColor * DstFactor$
BLENDFUNCTION_SUBTRACT	$SrcColor * SrcFactor - DstColor * DstFactor$
BLENDFUNCTION_REVERSE_SUBTRACT	$DstColor * DstFactor - SrcColor * SrcFactor$
BLENDFUNCTION_MIN	$\min (SrcColor * SrcFactor, DstColor * DstFactor)$ Programming Note: This is a superset of the OpenGL <i>min</i> function.
BLENDFUNCTION_MAX	$\max (SrcColor * SrcFactor, DstColor * DstFactor)$



Blend Function	Operation (for each color component)
	Programming Note: This is a superset of the OpenGL <i>max</i> function.

Post-Blend Color Clamping

(See *Pre-Blend Color Clamping* above for a summary table regarding clamping)

Post-Blend Color clamping is available only if Blending is enabled.

If Blending is enabled, the clamping of blending output color components is controlled by **Post-Blend Color Clamp Enable**. If ENABLED, the color components output from blending are clamped to the range specified by **Color Clamp Range**. If DISABLED, no clamping is performed at this point.

Regardless of the setting of **Post-Blend Color Clamp Enable**, when Blending is enabled color components will be automatically clamped to (at least) the rendertarget surface format range at this stage of the pipeline.

Dithering

Dithering is used to give the illusion of a higher resolution when using low-bpp channels in color buffers (e.g., with 16bpp color buffer). By carefully choosing an arrangement of lower resolution colors, colors otherwise not representable can be approximated, especially when seen at a distance where the viewer's eyes will average adjacent pixel colors. Color dithering tends to diffuse the sharp color bands seen on smooth-shaded objects.

A four-bit dither value is obtained from a 4x4 Dither Constant matrix depending on the pixel's X and Y screen coordinate. The pixel's X and Y screen coordinates are first offset by the **Dither Offset X** and **Dither Offset Y** state variables (these offsets are used to provide window-relative dithering). Then the two LSBs of the pixel's screen X coordinate are used to address a column in the dither matrix, and the two LSBs of the pixel's screen Y coordinate are used to address a row. This way, the matrix repeats every four pixels in both directions.

The value obtained is appropriately shifted to align with (what would be otherwise) truncated bits of the component being dithered. It is then added with the component and the result is truncated to the bit depth of the component given the color buffer format.

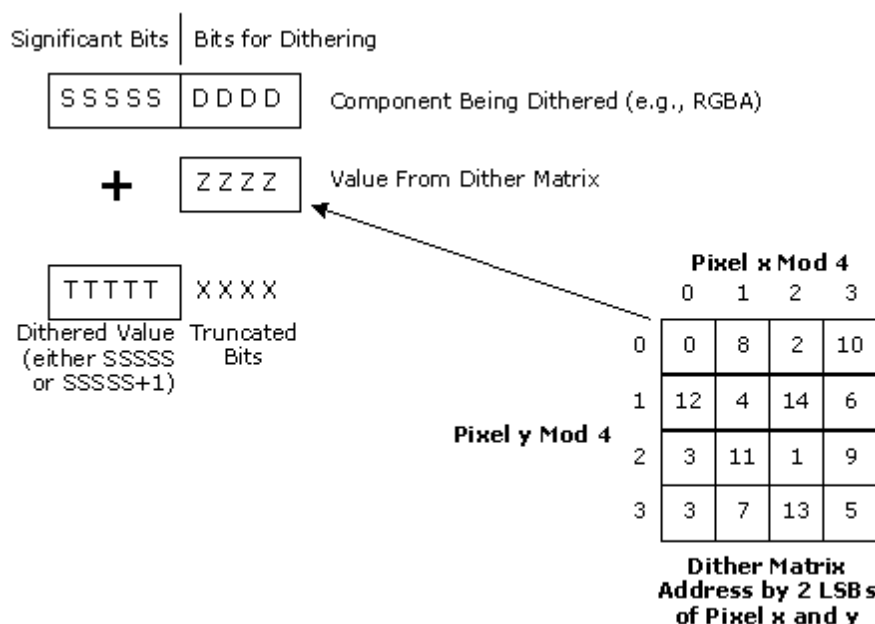

B6852-01

Dithering Process (5-Bit Example)

Logic Ops

The Logic Ops function is used to combine the incoming "source" pixel color/alpha values with the corresponding "destination" color/alpha contained in the ColorBuffer, using a logic function.

The Logic Op function is enabled by the **LogicOp Enable** state variable. If DISABLED, this function is ignored and the incoming pixel values are passed through unchanged.

Programming Notes

Project	Programming Note
	Color Buffer Blending and Logic Ops must not be enabled simultaneously, or behavior is UNDEFINED.
HSW	Logic Ops are supported on all blendable render targets and render targets with *INT formats.

The following table lists the supported logic ops. The logic op is selected using the **Logic Op Function** field in COLOR_CALC_STATE.



Logic Ops

LogicOp Function	Definition (S=Source, D=Destination)
LOGICOP_CLEAR	all 0's
LOGICOP_NOR	NOT (S OR D)
LOGICOP_AND_INVERTED	(NOT S) AND D
LOGICOP_COPY_INVERTED	NOT S
LOGICOP_AND_REVERSE	S AND NOT D
LOGICOP_INVERT	NOT D
LOGICOP_XOR	S XOR D
LOGICOP_NAND	NOT (S AND D)
LOGICOP_AND	S AND D
LOGICOP_EQUIV	NOT (S XOR D)
LOGICOP_NOOP	D
LOGICOP_OR_INVERTED	(NOT S) OR D
LOGICOP_COPY	S
LOGICOP_OR_REVERSE	S OR NOT D
LOGICOP_OR	S OR D
LOGICOP_SET	all 1's

Buffer Update

The Buffer Update function is responsible for updating the pixel's Stencil, Depth and Color Buffer contents based upon the results of the Stencil and Depth Test functions. Note that Kill Pixel and/or Alpha Test functions may have already discarded the pixel by this point.

Stencil Buffer Updates

If and only if stencil testing is enabled, the Stencil Buffer is updated according to the **Stencil Fail Op**, **Stencil Pass Depth Fail Op**, and **Stencil Pass Depth Pass Op** state (or their backface counterparts if **Double Sided Stencil Enable** is ENABLED and the pixel is from a back-facing object) and the results of the Stencil Test and Depth Test functions.

Stencil Fail Op and **Backface Stencil Fail Op** specify how/if the stencil buffer is modified if the stencil test fails. **Stencil Pass Depth Fail Op** and **Backface Stencil Pass Depth Fail Op** specify how/if the stencil buffer is modified if the stencil test passes but the depth test fails. **Stencil Pass Depth Pass Op** and **Backface Stencil Pass Depth Pass Op** specify how/if the stencil buffer is modified if both the stencil and depth tests pass. The operations (on the stencil buffer) that are to be performed under one of these (mutually exclusive) conditions is summarized in the following table.



Stencil Buffer Operations

Stencil Operation	Description
STENCILOP_KEEP	Do not modify the stencil buffer
STENCILOP_ZERO	Store a 0
STENCILOP_REPLACE	Store the <i>StencilTestReference</i> reference value
STENCILOP_INCRSAT	Saturating increment (clamp to max value)
STENCILOP_DECRSAT	Saturating decrement (clamp to 0)
STENCILOP_INCR	Increment (possible wrap around to 0)
STENCILOP_DECR	Decrement (possible wrap to max value)
STENCILOP_INVERT	Logically invert the stencil value

Any and all writes to the stencil portion of the depth buffer are enabled by the **Stencil Buffer Write Enable** state variable.

When writes are enabled, the **Stencil Buffer Write Mask** and **Backface Stencil Buffer Write Mask** state variables provide an 8-bit mask that selects which bits of the stencil write value are modified. Masked-off bits (i.e., mask bit == 0) are left unmodified in the Stencil Buffer.

Programming Notes:

- The Stencil Buffer can be written even if depth buffer writes are disabled via **Depth Buffer Write Enable**.

Depth Buffer Updates

Any and all writes to the Depth Buffer are enabled by the **Depth Buffer Write Enable** state variable. If there is no Depth Buffer, writes must be explicitly disabled with this state variable, or operation is UNDEFINED.

If depth testing is disabled or the depth test passed, the incoming pixel's depth value is written to the Depth Buffer. If depth testing is enabled and the depth test failed, the pixel is discarded – with no modification to the Depth or Color Buffers (though the Stencil Buffer may have been modified).

Color Gamma Correction

Computed RGB (not A) channels can be gamma-corrected prior to update of the Color Buffer.

This function is automatically invoked whenever the destination surface (render target) has an SRGB format (see surface formats in *Sampling Engine*). For these surfaces, the computed RGB values are converted from gamma=1.0 space to gamma=2.4 space by applying a $^{2.4}$ exponential function.



Color Buffer Updates

Finally, if the pixel has not been discarded by this point, the incoming pixel color is written into the Color Buffer. The **Surface Format** of the color buffer indicates which channel(s) are written (e.g., R8G8_UNORM are written with the Red and Green channels only). The **Color Buffer Component Write Disables** from the Color buffer's SURFACE_STATE provide an independent write disable for each channel of the Color Buffer.

Pixel Pipeline State Summary

COLOR_CALC_STATE

3DSTATE_BLEND_STATE_POINTERS

3DSTATE_BLEND_STATE_POINTERS

3DSTATE_DEPTH_STENCIL_STATE_POINTERS

3DSTATE_DEPTH_STENCIL_STATE_POINTERS

COLOR_CALC_STATE

COLOR_CALC_STATE

DEPTH_STENCIL_STATE

DEPTH_STENCIL_STATE

BLEND_STATE

BLEND_STATE

Programming Note: CC Unit also receives 3DSTATE_WM_HZ_OP and 3DSTATE_PS_EXTRA.

CC_VIEWPORT

CC_VIEWPORT

Other Pixel Pipeline Functions

Statistics Gathering

If **Statistics Enable** is set in 3DSTATE_WM, the PS_DEPTH_COUNT register (see Memory Interface Registers in Volume 1a, *GPU Overview*) is incremented once for each pixel (or sample) that passes the depth, stencil and alpha tests. Note that each of these tests is treated as passing if disabled. This count is accurate regardless of whether **Early Depth Test Enable** is set. To obtain the value from this register at a



deterministic place in the primitive stream without flushing the pipeline, however, the PIPE_CONTROL command must be used. See Volume 2a, *3D Pipeline*, for details on PIPE_CONTROL.

MCS Buffer for Render Target(s)

Project:		HSW
<p>MCS buffer can be enabled for two purposes described below. MCS buffer can be controlled using two mechanisms:</p> <ol style="list-style-type: none"> 1. MMIO bit Cache Mode 1 (0x2124) register bit 5 2. RT surface state <p>The following table summarizes modes of operation related to MCS buffer:</p>		
Cache Mode MMIO Bit (Please refer to Vol 1c)	MSC Enable (Surface State)	Operation
1 (feature disable)	X	Normal mode of operation i.e. no MSAA compression and no color clear
0	0	Normal mode of operation i.e. no MSAA compression and no color clear
0	1	Depending on the Number of multi-samples, either MSAA compression OR color clear is enabled

Project	MSAA	Width of Clear Rect	Height of Clear Rect
HSW	4X	Ceil(1/8*width)	Ceil(1/2*height)
HSW	8X	Ceil(1/2*width)	Ceil(1/2*height)

- MSAA Compression:** Multi-sample render target is bound to the pipeline and MSAA compression feature is enabled. In this case, MCS buffer stores the information required for MSAA compression algorithm. The size and layout of the MCS buffer is based on per-pixel RT. For 4X and 8X MSAA, MCS buffer element is 8bpp and 32bpp respectively. Height, width, and layout of MCS buffer in this case must match with Render Target height, width, and layout. MCS buffer is tiledY. When MCS buffer is enabled and bound to MSRT, it is required that it is cleared prior to any rendering. A clear value can be specified optionally in the surface state of the corresponding RT. Clear pass for this case requires that scaled down primitive is sent down with upper left coordinate to coincide with actual rectangle being cleared. For MSAA, clear rectangle's height and width need to as show in the following table in terms of (width,height) of the RT.
- Fast Color Clear:** When non multi-sample render target is bond to the pipeline and MSC buffer is enabled, MCS buffer is used as an intermediate (coarse granular) buffer per RT. Hence, MCS buffer



is used to improve render target clear. When MCS is buffer is used for color clear of non-multisampler render target, the following restrictions apply:

Color Clear of Non-MultiSampler Render Target Restrictions

Project	Restrictions																																	
	Support is limited to tiled render targets.																																	
HSW	Support is for non-mip-mapped and non-array surface types only.																																	
	Clear is supported only on the full RT; i.e., no partial clear or overlapping clears.																																	
	<p>The following table describes the RT alignment:</p> <table border="1"> <thead> <tr> <th></th> <th>Pixels</th> <th>Lines</th> </tr> </thead> <tbody> <tr> <td>TiledY RT CL</td> <td></td> <td></td> </tr> <tr> <td> bpp</td> <td></td> <td></td> </tr> <tr> <td> 32</td> <td>8</td> <td>4</td> </tr> <tr> <td> 64</td> <td>4</td> <td>4</td> </tr> <tr> <td> 128</td> <td>2</td> <td>4</td> </tr> <tr> <td>TiledX RT CL</td> <td></td> <td></td> </tr> <tr> <td> bpp</td> <td></td> <td></td> </tr> <tr> <td> 32</td> <td>16</td> <td>2</td> </tr> <tr> <td> 64</td> <td>8</td> <td>2</td> </tr> <tr> <td> 128</td> <td>4</td> <td>2</td> </tr> </tbody> </table>		Pixels	Lines	TiledY RT CL			bpp			32	8	4	64	4	4	128	2	4	TiledX RT CL			bpp			32	16	2	64	8	2	128	4	2
	Pixels	Lines																																
TiledY RT CL																																		
bpp																																		
32	8	4																																
64	4	4																																
128	2	4																																
TiledX RT CL																																		
bpp																																		
32	16	2																																
64	8	2																																
128	4	2																																
	MCS buffer for non-MSRT is supported only for RT formats 32bpp, 64bpp, and 128bpp.																																	
	Clear pass must have a clear rectangle that must follow alignment rules in terms of pixels and lines as shown in the table below. Further, the clear-rectangle height and width must be multiple of the following dimensions. If the height and width of the render target being cleared do not meet these requirements, an MCS buffer can be created such that it follows the requirement and covers the RT.																																	
	Clear rectangle must be aligned to two times the number of pixels in the table shown below due to 16X16 hashing across the slice.																																	



Project:		HSW	
	Pixels	Lines	
TiledY RT			
bpp			
32	128	128	
64	64	128	
128	32	128	
TiledX RT			
bpp			
32	256	64	
64	128	64	
128	64	64	

To optimize the performance MCS buffer (when bound to 1X RT) clear similarly to MCS buffer clear for MSRT case, clear rect is required to be scaled by the following factors in the horizontal and vertical directions:

Project:		HSW	
	Horizontal Scale Down Factor	Vertical Scale Down Factor	
MCS CL for TiledY RCC			
bpp			
32	64	64	
64	32	64	
128	16	64	
MCS CL for TiledX RCC			
bpp			
32	128	32	
64	64	32	
128	32	32	



Resolve rectangle must not be scaled if MCS Resolve Optimization is disabled in the Cache Mode register.

The following are the general SW requirements for MCS buffer clear functionality:

- At the time of Render Target creation, SW needs to create clear-buffer, i.e., MCS buffer.
- At the clear time, clear value for that RT must be programmed and clear enable bit must be set in the surface state of the corresponding RT.
- SW must clear the RT with setting a RT clear bit set in the PS state during the clear pass as described in the following sub-section.
- Since only one RT is bound with a clear pass, only one RT can be cleared at a time. To clear multiple RTs, multiple clear passes are required.
- If Software wants to enable Color Compression without Fast clear, Software needs to initialize MCS with zeros.
- Before binding the "cleared" RT to texture OR honoring a CPU lock OR submitting for flip, SW must ensure a resolve pass. Such a resolve pass is described in the following sub-section.

Render Target Fast Clear

Fast clear of the render target is performed by setting the **Render Target Fast Clear Enable** field in 3DSTATE_PS and rendering a rectangle. The size of the rectangle is related to the size of the MCS.

The following is required when performing a render target fast clear:

- The render target(s) is/are bound as they normally would be, with the MCS surface defined in SURFACE_STATE.
- A rectangle primitive of the same size as the MCS surface is delivered.
- The pixel shader kernel requires no attributes, and delivers a value of 0xFFFFFFFF in all channels of the render target write message. The replicated color message should be used.
- **Depth Test Enable, Depth Buffer Write Enable, Stencil Test Enable, Stencil Buffer Write Enable, and Alpha Test Enable** must all be disabled.
- After Render target fast clear, pipe-control with color cache write-flush must be issued before sending any DRAW commands on that render target.

Render Target Resolve

If the MCS is enabled on a non-multisampled render target, the render target must be resolved before being used for other purposes (display, texture, CPU lock). The clear value from SURFACE_STATE is written into pixels in the render target indicated as clear in the MCS. This is done by setting the **Render Target Resolve Enable** field in 3DSTATE_PS and rendering a full render target sized rectangle. Once this is complete, the render target will contain the same contents as it would have had the rendering been performed with MCS surface disabled. In a typical usage model, the render target(s) need to be resolved after rendering and before using it as a source for any consecutive operation.



When performing a render target resolve, PIPE_CONTROL with end of pipe sync must be delivered.

Project:		HSW
There are the following added requirements when performing a render target resolve.		
A rectangle primitive must be scaled down by the following factors with respect to render target being resolved.		
Resolve rectangle scaling for TiledY RCC		
	width scale down factor	height scale down factor
bpp		
32	4	2
64	2	2
128	1	2
Resolve rectangle scaling for TiledX RCC		
bpp		
32	8	1
64	4	1
128	2	1

Project:	HSW
The pixel shader kernel requires no attributes, but must deliver a render target write message covering all pixels and all render targets desired to be resolved The color data in these messages is ignored (the replicated color message is required).	

Note: Depth Test Enable, Depth Buffer Write Enable, Stencil Test Enable, Stencil Buffer Write Enable, and Alpha Test Enable must all be disabled.

Note: This render target resolve procedure is not supported on multisampled render targets. Unresolved multisampled render targets are directly supported by the sampling engine, which resolves clear values in addition to decompressing the surface This applies to both *ld2dms* and *sample2dms* messages.



L3/URB

This section discusses GFX L3 cache. The included topics are:

- Overview
- Atomics
- L3 Coherency
- L3 Allocation & Programming
- L3 Interfaces
- State Arbiter
- L3 Invalidation and Flush Flows
- Shared Local Memory (SLM)
- Dynamic Parity Feature for GFX L3 Cache
- L3 Register Space

L3\$/URB

GFX L3 cache is introduced for Gen7 GFX core as a large storage which backs up various L2/L1 caches on many clients. It provides a simple way based partitioning option for each or a cluster of clients to get a dedicated chunk of the cache. It also acts as a GFX URB and can be configured as highly banked memory for EUs/ROWS.

In order to provide the bandwidth needed L3 has been separated into 4x128KB structures which can be accessed concurrently. A 2x clocking is introduced to further enhance the bandwidth and cover the limitations of SRAM (6T) design.

- Formed as 4 (2 for GT1) individual banks each with 128KB in size
- Each logical bank consists of
 - Data Array
 - Tag Array
 - LRU Array (implements a Pseudo Least Recently Used algorithm)
 - State Array
 - SuperQ Data Buffer
 - Atomic Processing Unit
- The rest of the support logic around L3 are
 - SuperQ (main scheduler)
 - Ingress/Egress queues to L3/SQ (L3 arbiter)
 - CAM structures to maintain coherency.
 - Crossbars for data routing



- Use of 2x/1x clocking
- L3 operates in GFX coherent domain
- A portion of L3 can be allocated as highly banked memory

L3\$ Cache Configuration

- 4x128KB cache, 64 logical ways (per slice)
- 64B Cacheline with a portion capable of highly banked memory (with 16x4B capability)
- Interface 64B to SQDB for the fill/write path, 64B Read/Evict path to SQDB
- Data Array built via 6T cells
 - Data protection via parity
- TAG/LRU/STATE (using gen-ram via RLS flows)
 - 32-bit GFX addressing support in TAG
 - 2 bit state
 - Intel pseudo-LRU implementation for selecting the line to be replaced
- Repetition rates for each operation
 - All operations – 1 every 2x clock
 - With b2b restriction for same type of accesses (i.e. read to read or write to write)

Memory Object Control State on Cacheability

This 4-bit field is used in various state commands and indirect state objects to define MLC/LLC cacheability and graphics data type for memory objects. For details of the field see the GPU Overview section.

Atomics

An atomic operation may involve both reading from and then writing to a memory location. Atomic operations apply only to either *u#* (Unordered Access Views) or *g#* (Thread Group Shared Memory). It is guaranteed that when a thread issues an atomic operation on a memory address, no write to the same address from outside the current atomic operation by any thread can occur between the atomic read and write.

If multiple atomic operations from different threads target the same address, the operations are serialized in an undefined order. This serialization happens outside of the L3 control logic.

Atomic operations do not imply a memory or thread fence. If the program author/compiler does not make appropriate use of fences, it is not guaranteed that all threads see the result of any given memory operation at the same time, or in any particular order with respect to updates to other memory addresses.



Atomicity is implemented at 32-bit granularity. If a load or store operation spans more than 32-bits, the individual 32-bit operations are atomic, but not the whole.

Limitation: Atomic operations on Thread Group Shared Memory are atomic with respect to other atomic operations, as well as operations that only perform reads ("load"s). However atomic operations on Thread Group Shared Memory are NOT atomic with respect to operations that perform only writes ("store"s) to memory. Mixing of atomics and stores on the same Thread Group Shared Memory address without thread synchronization and memory fencing between them produces undefined results at the address involved. This limitation arises because some implementations of loads and stores do not honor the locking semantics for implementing atomics. It turns out this has no impact on loads, since they are guaranteed to retrieve a value either before or after an atomic (they will not retrieve partially updated values, given they are all defined at 32-bit quanta). However store operations could find their way into the middle of an atomic operation and thus have their effect possibly lost.

In L3 or SLM, the atomic operation leads to a read-modify-write operation on the destination location with the option of returning value back to requester. The table below is defined as a list of atomic operations needed:

Atomic Operation	Description	New Destination Value	Return Value (optional)
Atomic_AND	Single component 32-bit bitwise AND of operand src0 into dst at 32-bit per component address dstAddress, performed atomically.	"old_dst" AND "src0"	old_dst
Atomic_OR	Single component 32-bit bitwise OR of operand src0 into dst at 32-bit per component address dstAddress, performed atomically.	"old_dst" OR "src0"	old_dst
Atomic_XOR	Single component 32-bit bitwise XOR of operand src0 into dst at 32-bit per component address dstAddress, performed atomically.	"old_dst" XOR "src0"	old_dst
Atomic_MOVE	Replacement of the dst with src0.	"src0"	old_dst
Atomic_INC	Single component 32-bit integer increment of dst back into dst	"old_dst + 1"	old_dst
Atomic_DEC	Single component 32-bit integer decrement of dst back into dst	"old_dst - 1"	old_dst
Atomic_ADD	Single component 32-bit integer add of operand src0 into dst at 32-bit per component address performed atomically. Insensitive to sign	"old_dst + src0"	old_dst
Atomic_SUB	Single component 32-bit integer subtraction of operand src0 into dst at 32-bit per component address performed atomically. Insensitive to sign	"old_dst - src0"	old_dst
Atomic_RSUB	Single component 32-bit integer subtraction of operand dst from src0 into dst at 32-bit per component address performed atomically. Insensitive to sign	"src0 - old_dst"	old_dst



Atomic Operation	Description	New Destination Value	Return Value (optional)
Atomic_IMAX	Single component 32-bit signed MAX of operand src0 into dst at 32-bit per component address dstAddress, performed atomically.	IMAX (old_dst, src0)	old_dst
Atomic_IMIN	Single component 32-bit signed MIN of operand src0 into dst at 32-bit per component address dstAddress, performed atomically.	IMIN (old_dst, src0)	old_dst
Atomic_UMAX	Single component 32-bit unsigned MAX of operand src0 into dst at 32-bit per component address dstAddress, performed atomically.	UMAX (old_dst, src0)	old_dst
Atomic_UMIN	Single component 32-bit unsigned MIN of operand src0 into dst at 32-bit per component address dstAddress, performed atomically.	UMIN (old_dst, src0)	old_dst
Atomic_CMP/WR	Single component 32-bit value compare of operand src0 with dst at 32-bit per component address dstAddress If the compared values are identical, the single-component 32-bit value in src1 is written to destination memory, else the destination is not changed The entire compare+write operation is performed atomically	(src0 == old_dst)? src1: old_dst	old_dst
Atomic_PREDEC	Single component 32-bit integer decrement of dst back into dst	"old_dst - 1"	new_dst
Atomic_CMP/WR8B	Single component 64-bit value compare of operand src0 with dst at 64-bit per component address dstAddress If the compared values are identical, the single-component 64-bit value in src1 is written to destination memory, else the destination is not changed The entire compare+write operation is performed atomically	(src0 == old_dst)? src1: old_dst	old_dst

The DC request for atomic will have the proper DW only byte enables set for the 32 bit of interest. The address down to bit[2] (dword address) will also be provided to point to correct DW out of 16 lanes in 64Bytes.

The processing of atomics will follow 2 separate pipelines of operation (either SLM or L3) depending on the destination of the access.

Atomics when disabled in L3, are performed at the GFX interface. Non-L3 atomics are not going to be as performant and requires x9030[3:2]="01" to operate.



Atomics in L3

Atomics in L3 are handled separately in each bank, to achieve this function 2 Atomics blocks are instantiated along with each bank. Each operand being moved to SQ also moves its data (up to 2 DWs) into an assigned atomics block to be used later on (when the destination data is available).

A separate credit is given to L3 arbiter for atomics, once an atomic request is moved from L3 arbiter to SQ – both the SQ credits and Atomics credits need to be deducted to regulate the number of atomic requests in SQ. For GT2, this process allows up to 8 atomics to be performed in a given clock.

The request interface allows only 1 DW of atomics per request, data from DC will be given on DW0 (also in DW1 if src1 is given) for all atomic operations regardless of the address of byte enables. Cacheline address will be provided on the interface with proper Byte Enables singling the DW location of the destination.

If final data is returned to client (optional), the DW of interest will be given in the same position pointed out by byte enables (in fact the same DW will be replicated over 16 positions).

Atomics in SLM

SLM pipeline has a mechanism to handle atomics similar to L3/URB pipeline. There is only 1 ALU per SLM subbank. The protocol between DC and L3 allows one atomics to be performed at a given time, the SLM controller will stall the interface if needed. Per atomics request from the DC, only ONE DW can be active on one SLM bank. SLM pipeline can execute b2b atomics request (1 every 1x clock) as long as b2b operations do not conflict on the same bank. If conflict is detected a single clock of bubble is inserted into pipeline in order to update the corresponding bank with SLM output before next operation can be performed (*see SLM pipeline details*)

Data from DC will be always given on DW0 and DW (if needed) and VALIDs will point to the bank of interest out of 16 banks of SLM. Correct set of byte enables should be provided which is active for the valid bank.

DW of interest is returned to DC on the byte enable corresponding lane of the cacheline.

Atomics in URB

Simple atomics are possible to be processed for URB locations as well. The process should fall out from the L3 path of the atomics and is restricted similar to L3 atomics.

L3 Allocation & Programming

L3 Cache allocation is done on a per way basis which should be consistent across all 4 banks (2 banks for GT1). The way allocation between URB and any of the L3 clients can only be changed post pipeline flush where L3 contains no data. This is required for stream based flushes to be dependent on the way allocation of these corresponding streams. S/W should not be removing ways under a particular stream and expect a later pipelined stream flush to target all the corresponding locations. The stream based



flush will be performed on the existing way allocation of that stream, there is no history of previous way allocation tracked in the hardware.

L3 Cache has been divided into following client pools:

- **Shared Local Memory:** When enabled its size is always fixed to 128KB (64KB for GT1)
- **URB:** Local memory space, provides a flexible allocation on per 8KB granularity
- **DC:** Data Cluster Data type
- **Inst/State:** Both instructions and state allocation is combined
- **Constants:** Pull constants for EUs
- **Textures:** texture allocation to back-up L2\$

In addition to these sub-groups, a collection of groups are generated to bundle multiple clients under the same allocation set:

- **All L3 Clients:** DC, Inst/State, Constants & Textures
- **Read-Only Clients:** Inst/State, Constants & Textures

Each of the L3 way allocations are managed via pLRU, hence best performance can be attained via assigning a power-of-2 number of ways. This is to ensure pLRU to distribute the ways w/o hot spotting within that client's group. Even though design provides a flexible (per way basis) programming model for way allocation for each client following table is given for validation and s/w programming models. The programming options in the following table represents most likely cases for different operation modes.

For GT1, hardware will retain 2 of the L3 banks hence all following allocations will be reduced half the size.

Only the following configurations are allowed for programming.

Non-SLM Mode Allocation

Normal L3/URB mode (non-SLM mode), uses all 4 banks of L3 equally to distribute cycles. The following allocation is a suggested programming model. Note all numbers below are given in KBytes.



Normal Banked - No SLM									
Normal Bank	SLM	URB	Rest	DC	RO	I/S	C	T	Sum
0	0	256	0	0	256	0	0	0	512
1	0	256	0	128	128	0	0	0	512
2	0	256	0	32	0	64	32	128	512
3	0	224	0	64	0	64	32	128	512
4	0	224	0	128	0	64	32	64	512
5	0	224	0	64	0	128	32	64	512
6	0	224	0	0	0	128	32	128	512
7	0	256	0	0	0	128	0	128	512

Additional Supported Configuration:

The configuration for {SLM = 0,URB = 224,DC = 32,RO = 256,IS = 0,C = 0,T =0, SUM 512} was validated as a later supported configuration and can be utilized if desired.

SLM Mode Allocation

With the existence of Shared Local Memory, a 64KB chunk from each of the 2 L3 banks will be reserved for SLM usage. The remaining cache space is divided between the remaining clients. SLM allocation is done via reducing the number of ways on the two banks from 64 to 32.

Shared Local Memory Mode - highly banked - aka MMemory									
Shared Local	SLM	URB	Rest	DC	RO	I/S	C	T	Sum
0	128	128	0	128	128	0	0	0	512
1	128	128	0	64	64	64	64	64	512
2	128	128	0	32	64	32	128	128	512
3	128	128	0	32	128	32	64	512	512

Given the reduction on the 2 banks for L3, we have a unique problem of how to manage HASH between 4 un-equal size banks. The way to address that issue is to identify "Low Bandwidth" clients and allocate them into un-even ways of the large banks and handle them via a 2-way HASH. The remaining clients are allocated between 4 banks with the equal number of ways on each bank. The shaded clients in corresponding table are supposed to correspond to low bandwidth clients and their total should be 128KB.

Note that, having mixture of 2 hashes need to ensure "there are no coherency requirements between the high b/w and low b/w clients". This solution prevents any producer/consumer models cross groups



within L3. When programming the low b/w vs high b/w client profile, the need for coherency with the L3 fabric has to be considered.

Note that URB needs to be set as low b/w client in SLM mode, else the hash will fail. This is a required s/w model.

Additional Supported Configuration:

The configuration for {SLM = 128,URB = 128,DC = 0,RO = 256,IS = 0,C = 0,T =0, SUM 512} was validated as a later supported configuration and can be utilized if desired. For this configuration, global atomics must be programmed to be in GTI.

L3 Invalidation and Flush Flows

Read Only Stream Invalidations

All read-only stream invalidations are done at the TOP of the pipe and communicated to L3 fabric directly from the main command streamer. Once send to L3, command streamer can kick off the next workload to reuse the same memory. There are four type streams that can be covered individually or overlapped:

- Texture Invalidation
- Instruction Invalidation
- Constant Invalidation
- State Invalidation

For all types of invalidations the flows are the same from L3 arbiter perspective: first invalidation will directly come from the command streamer and the "state invalidation" is sent via state arbiter unit.

L3 arbiter will propagate the invalidation only after the corresponding streams' requests are retired to superQs. Once a particular invalidation is received, L3 arbiter will put a marker where all the existing requests from that stream. This will allow the already existing requests to be sent to superQ while accepting new requests, however new requests should never be sent to SuperQ until the existing invalidation is complete. Once all existing (marked requests) moved to SQ, L3 arbiter will propagate the invalidation request to SuperQ and keep the corresponding ingress FIFOs blocked.

Note: There may be two sources of the corresponding stream (i.e. Textures from either half-slice arbiters...). L3 arbiter needs to ensure both streams are serviced before propagating the "invalidation to SuperQ".

Once SuperQ receives the invalidation, it will start monitoring particular streams transactions that could be still in SuperQ and wait for them to retire. If there is no such requests, this process would be immediate. The invalidation will be forwarded to L3 as SuperQ ensures there is no more requests in its slots with the matching clientID assignment.

Once L3 cache receives the invalidation, it is guaranteed that none of its requests in the TAG pipeline belongs to OLD marked requests from the stream getting the invalidation. SuperQ already guarantees



this process by waiting for the retirement of the marked requests. TAG pipeline controller will stall the operations and wait for the TAG pipeline to clear than send the indication to STATE Array controller. For the ways that are corresponding to invalidation type, all ways for matching stream type will be updated in one shot. Once invalidation is complete, each L3 bank will send the indication to Pixel Arbiter (GAP). Note that multiple invalidations will be serialized in L3.

GAP will collect all invalidation requests from 4 banks (2 banks for GT1) and make sure all are complete before sending this completion back to corresponding L3 arbiters. L3 arbiters will ungate the ingress FIFOs of the completed invalidation as they complete the last step required.

This is exception part of the Read-Only Stream invalidations where state arbiter needs to stop sending new requests to L3 arbiters and ensure all pre-committed requests already sent to L3 arbiters:

- Stop and discard any prefetch requests that may be ongoing.
- Finish any state requests with the length fields.

Once above conditions are satisfied the "state invalidation" will be forwarded to L3 arbiters and state arbiter will stop sending processing any other state requests while processing the invalidation. The ingress FIFOs will be kept blocked towards the arbiter until L3 arbiters send an indicator (all 4 of them) to state arbiter for the completion of the state invalidation. Note that this is an extra step for L3 arbiters only for the case of state invalidation within Read-Only streams.

Note that state arbiter needs to accumulate any new state requests that falls behind the invalidation event and not process them until the state invalidation complete indicator is seen from GAP. It needs to ensure old state data is cleared before sending the new state requests from clients.

There is a possibility where multiple invalidations could exist for a given stream. This is where L3 arbiters need to coordinate when the invalidation requests would be processed. As L3 arbiter receives a particular invalidation to the time response is received from GAP, there could be yet another invalidation for the same stream. However since the ingress FIFOs are blocked, new invalidation request should not be processed before the prior request is complete. When L3 arbiter receives the completion from GAP, it will start processing the new invalidation as if it was received right at the same cycle.

Same rules apply for state arbiter as well where while the completion for a prior invalidation is pending, there may be another invalidation request from the main command streamer. State arbiter will hold off the execution of the newer invalidation until the completions are seen from the L3 arbiters.

Note that there could be third, fourth invalidations while the very invalidation is being processed. All invalidations for a given stream could be collapsed while the prior one is being processed.

Pipelined Flush for Writes

Pipelined flush for data cluster writes will be propagated from DC directly to L3 arbiters as their buffers are flushed. L3 arbiters will be getting a flush indicator from each DC independently, there is no point of acting on the first flush indicator, it is easier to wait for both DCs to send their flush request and process them together. Once both flush indicators are seen, L3 arbiter will flush all its ingress FIFOs and block outlet of them being processed. L3 arbiter should not be sending any other requests to SuperQs until a completion is seen.



SuperQ as a response to Write Flush will wait for all its slots to retire, this is to prevent any boundary cases and ensure all writes are retired to L3 (if any). Once emptied, SQ will start accumulating "Flush" requests to the defined sets and ways (defined as data cluster reserved ways) and walk through each entry of the L3. These flush requests are to invalidate and evict any modified lines that may be present in L3s.

After all defined ways are walked with FLUSH requests, SuperQ should wait for empty indicator once again. This is to make sure all evicted data is retired towards GAP.

As GAP receives the flush complete indicator from each bank of L3 (4 for GT2 and 2 for GT1), it will ensure the eviction path is retired towards GAM, Once all done, it will send an indicator to PSD units in each half-slice. Same signal will be received by all L3 arbiters and used to un-block their interfaces towards SuperQ.

Note that SuperQ should not release any credits to L3 arbiter when retiring an internally generated flush request.

Similar to RO invalidations, the status of the write flush can also be tracked via register space.

Global Invalidation

Once written a global indicator will be sent to L3 arbiters and state arbiter which will kick-off all invalidations at once. The same register space will collect all completion from L3 arbiters and state arbiter to clear the same bit.

Register bit can be polled by s/w to track to completion of all invalidations.

Bit	Access	Default Value	Description
0	RW/C	0	L3 Global Invalidations: Once written it will kick off a global invalidation for L3 both on RO and WR streams. S/W is expected to write logic1 to kick-off the invalidation and H/W will clear the bit once all invalidations are complete. Meanwhile S/W can poll the bit to track the completion of invalidation.

Shared Local Memory (SLM)

Shared local memory (aka highly-banked memory) is a portion of L3 which will be dedicated to EUs as a local memory when enabled. The accesses are only possible through data cluster with the destination flag set as SLM. In order to support a highly banked design, 2 of the L3 banks are structured to have 16x4KB portion which could be accessed independently per clock. This part of the L3 can support 16 dw size accesses (per SLM) in a given clock cycle.

These 16 banks can either be used as L3/URB or used as shared local memory with parallel accesses to all banks. The choice of enabling SLM mode is done through MMIO programming

Bit	Access	Default Value	Description
-----	--------	---------------	-------------



Bit	Access	Default Value	Description
0	RW/C	0	<p>Enable Shared Local Memory: When set, it enables the use of 2 banks of L3 as shared local memory which allows 64KB of L3 to be banked as 16x4KB and allows independent accesses to all banks within the same clock cycle.</p> <p><i>Note: This mode can only be enabled once L3 content is completely flushed.</i></p>

SLM requests are forked around the L3 arbiter, post ingress FIFOs for DC. L3 arbiter delivers request/data to SLM controller upon the availability of credits. Request will be crossed to 2x clock domain routed to corresponding banks. Individual bank controls are managed via SLM controller which are muxed with L3/URB accesses. Note that SLM accesses do carry byte enables and needs to be honored towards the banks. If the request has atomic requirements, SLM controller will provide the data to ALU along with the atomic type. Output data is again managed with SLM controller towards the output cross bars.

SLM should not be accessed through the 3D pipe.

The state control fields are redefined to comprehend L3 addition as follows:

Bits	Name	Description	Security
2	GFDT	GFDT flag to color the displayable surfaces in LLC. This field is later used by GT to poll the LLC during query/flush mechanism and used to push the data to DRAM prior to Display Accesses.	
1:0	Cacheability Controls	Control for LLC and L3 cacheability fields Bit[1]: LLC cacheability Bit[0]: L3 cacheability 0: Access is NOT cacheable. 1: Access is cacheable.	

Dynamic Parity Feature for GFX L3 Cache

This document is meant to outline and describe dynamic parity detection function in graphics L3 cache.

Feature Definition

The concept of DPF is to provide a run-time protection for graphics L3 cache via parity detection and redundant rows. Parity errors are considered to be an extremely rare occurrence, but this mechanism provides a means to address them should they occur.

In order to mitigate error detection needs of graphics L3 cache, parity detection capability has been added to each sub-bank of the L3. A sub-bank is defined as a 16KB entity of the total 512KB cache. This would translate into 32 independent sub-banks which all have 2 independent redundant rows for a total of 64 possible replacement rows. Redundant rows can be activated to replace a row with identified parity errors via writing the address of the parity error row into hardware registers.

DPF allows the HW to notify SW (driver) when any single bit graphics L3 parity error has occurred and also provide a mechanism to allow SW to fix persistent bit errors where a susceptible bit fails multiple times.



In order to support robust GPGPU / compute workloads on HSW/gen7.5 graphics, Intel recommends that driver developers implement this suggested DPF flow. Regardless, all usages of the graphics L3 cache can benefit from the added parity protection.

Hardware and Software Flows

This section contain information on:

- Parity Generation & Detection
- Correction Using Parity Error data and Redundant Rows
- Number of Corrections
- Summary: Basic Algorithm

Parity Generation & Detection

The graphics L3 cache will generate 1-bit parity as data is stored in the cache. The parity bit will be written along with data for future verification. As the same content is accessed later in time, HW recalculates the parity based on read content and compares with the stored parity value.

Once a mismatch is detected, HW generates a parity interrupt for the graphics driver to service. Meanwhile, HW continues forward progress in execution. There is no implicit halt or execution stopping for the HW.

Along with the interrupt, the HW will update a set of registers to indicate which bank/sub-bank/row in which the error has been detected.

Correction Using Parity Error data and Redundant Rows

Each sub-bank contains 2 redundant rows which could be used to replace the rows with reported parity errors. The graphics driver, once servicing the parity interrupt, will access the reporting registers and record the bank/sub-bank/row information. This information should be stored in a permanent (non-volatile memory: ie: disk, registry or similar) location for future use by the graphics driver.

The graphics driver will then reset the render engine (i.e. render specific reset) to prevent propagation of the data with the parity error. Even though the graphics driver will terminate the context via resetting the GPU upon a parity interrupt, there is a possibility that the parity interrupt may be observed by the driver after the graphics context is complete or about to switch to a new context. For non-graphics workloads that require high data integrity, such as GPGPU computing, the driver should prevent this possible boundary case by polling the error reporting registers when a context completion or context switch interrupt is registered by the driver. Upon identifying that the error reporting registers are active, the driver should follow the same steps as servicing a parity interrupt.

Post any reset event (graphics reset, power up, etc..), the graphics driver retrieve the parity failure row information from non-volatile storage. It will then program the parity failure row information into corresponding bank/sub-bank registers and start normal graphics operation. Parity failure rows would then be effectively replaced with the extra redundant rows until next system reset.



In the extremely rare probability that redundant rows themselves have a parity errors, the parity error will be reported as the row they have replaced. SW drivers should recognize the use of redundant row and skip the replacement.

Number of Corrections

Given DPF is designed to deal with persistent errors, graphics drivers need to be able to identify which sub-bank rows are producing the most number of errors. Hence, the driver should keep a list of the reported parity error rows and record the number of times each row reports a parity error. If there are more than 2 parity error rows identified for a given sub-bank, the driver should replace the top two rows first (decided by historical error count). This will force rows with consistent parity errors to bubble up to the top of the list to be replaced.

SW driver tracking of parity error rows should be saved in non-volatile memory, so the driver can keep track of parity failure rows across reboot/reset.

Summary

Basic Algorithm:

- Each sub-bank has two redundant rows. (By HW design)
- Driver SW keeps track of each sub-bank's parity failure rows and keeps a count of failures of each row.
- Error count row information is saved to non-volatile memory, so it persists across reboot and graphics resets.
- At all times, the two redundant sub-bank rows are used to replace the highest count parity failure rows.
- SW always forces reset (graphics render reset is sufficient) on L3 errors.
- SW programs all necessary replacement rows after any reset.

Sub-banks with more than two persistent parity error rows

While not expected during normal lifetime operation, a problematic case could occur when the HW reports more than 2 rows on a particular sub-bank are causing parity errors. For this case, the graphics driver should keep replacing the rows, always selecting the two rows with the highest parity error failure count.

Interrupt Enabling

In order to enable proper DPF notification, the graphics driver must enable the correct interrupt paths from render command streamer (x20A8) as well as rest of the interrupt structures around GTISR (x44010), GTIMR (x44014), GTIIR (x44018), GTIER (x4401C). Bit5 has been selected for L3 parity interrupts. Please refer to the appropriate register sections for generic graphics interrupt enabling details.



Clearing the Error Reporting Registers

Clearing error status registers for the L3 cache should be done by writing to L3CD Error Status Register bit[13] with a logical value of 1. This should be done after an error is reported and a row has been replaced. The graphics driver can do this in two different ways:

1. Via batch buffer executed in HW (via LRI or LRM mechanisms)
2. Direct writes to graphics HW MMIO space

Direct reads and writes using graphics MMIO (for both error log and status registers) requires DOP level clock gating to be turned off as HW might have finished execution, which will result in a hang when accessing the L3 parity registers. This requires graphics MISCCPCTL bit 0 (x9424[0]) to be cleared prior to register updates. It must be set again post register updates. Do not leave the DOP clock gating bit cleared. Doing so will significantly affect graphics power.

Note that the HW parity registers will clear with any reset, hence error and row replacement registers will have to be re-programmed any time the driver performs a HW reset or driver is re-loaded.

Software Requirement on Silent Data Corruptions

HSW C-step added a mechanism to force h/w to hang while preventing the corrupted data to be exposed outside GPU.

It is expected for s/w to enable silent data corruption prevention for contexts where it matters.

Hardware Registers

Various registers are used to report and contain the parity error failing row information:



Error Report Registers

L3CDERRST1 - L3CD Error Status Register 1

B/D/F/Type: 0/0/0/SARBunit_Confi
 g
Address Offset: B008-B00Bh
Default Value: 00000000h
Access: RW; RO; WO;
Size: 32 bits

Bits	Access	Default Value	RST/PWR	Description
31:25	RO	0000000b	Core	Reserved (RSVD): Reserved
24:14	RWC	00000000000b	Core	Parity row address error (PRTYROWNUM): Data array address which has parity B1: Report the data array address which has the Error Itcd_sarb_parity_err_rownum[10:0] Once set by HW, it can be cleared only by MMIO Write of 1 to this register bit 13 .
13	RWC	0b	Core	Parity Error Valid (PRTYERRVLD): Parity Error valid Report the Parity Error Itcd_sarb_parity_err_valid Once set by HW, it can be cleared only by MMIO Write of 1 to this register bit 13 .
12:11	RWC	00b	Core	Parity error bank number (PRTYBNKNUM): bank number which has parity error Report the bank no. which has the Error Itcd_sarb_parity_err_banknum[1:0] Once set by HW, it can be cleared only by MMIO Write of 1 to this register bit 13 .
10:8	RWC	000b	Core	Parity Error sub-bank no (PRTYSBNKNUM):



Bits	Access	Default Value	RST/PWR	Description
				Parity Error in sub bank: ltcd0_sarb_parity_err_subbanknum[2:0] Once set by HW, it can be cleared only by MMIO Write of 1 to this register bit 13 .
7	RW	1b	Core	Parity report enable (LCPRTYRPTEN): sarbcf_csr_lc_parity_report_en this is the parity reporting enable, by default it is enabled. When enabled parity will be reported by ltcd to sarb. When disabled by driver, ltcd should not send out any parity error to SARB.
6:0	RO	00h	Core	Reserved (RSVD):



Row Replacement Registers

The range of row replacement registers is addresses xB070 (bank0/sub-bank0) to xB0EC (bank3/sub-bank7). Only the first register format is given below - all registers have the same format.

L3B0REG0 - L3 bank0 reg0 log error

B/D/F/Type:	0/0/0/SARBunit_Confi g
Address Offset:	B070-B073h
Default Value:	00000000h
Access:	RW; RO
Size:	32 bits

The log error registers of the L3 will maintain the bad row information for each of the 16KB sub-bank groups. The log should be programmed by the driver before any workloads are submitted if it is necessary to replace parity failing rows. The contents of the log register are included in any context save and restore by HW for RC6 power events.

All L3 error registers are put as part of HW context which could lead the same error to be reported multiple times (i.e. when context gets reloaded).

Bits	Access	Default Value	RST/PWR	Description
31:21	RW	000h	Core	Row Number for Error1 (RNUMERR1): Row Number for Error1: The physical row number where the parity error has been detected. The number of rows vary between 4K vs 8K/16K subbanks which requires 10bits vs 11bits respectively. This field contains the row# with the error.
20:17	RO	0000b	Core	Reserved (RSVD):
16	RW	0b	Core	Valid Error 1 (VLDERR1): Valid Error: The error located in field 15:5 is valid and corresponding logical 16KB group should bypass this row.
15:5	RW	000h	Core	Row Number for Error0 (RNUMERR0): Row Number for Error0: The physical row number where the parity error has been detected. The number of rows vary between 4K vs 8K/16K subbanks which requires 10bits vs 11bits respectively. This field contains the row# with the error.
4:1	RO	0000b	Core	Reserved (RSVD):



Bits	Access	Default Value	RST/PWR	Description
0	RW	0b	Core	Valid Error 0 (VLDERR0): Valid Error: The error located in field 15:5 is valid and corresponding logical 16KB group should bypass this row.

L3 Register Space

Note that the L3 register space is not cleared in engine or device specific resets. The registers in question need to be reprogrammed completely to known values at the context creation time.

L3 Space allocation can only be changed when the GPU pipeline is completely flushed. To guarantee that following two events need to be executed prior to the inline register updates to L3 allocation registers:

1. PIPECONTROL FLUSH, CS Stall set, with HDC Flush set, RO cache invalidation set if required (This flush command ensures the workload is completely drained, Datapipe is completely flushed followed by initiation of RO cache invalidation. Doesn't ensure RO cache invalidation is complete.)
2. PIPECONTROL FLUSH, CS Stall set, With HDC flush. (This flush ensures any prior RO cache invalidation in progress to be complete before processing flush for this command, this will avoid RO cache invalidation colliding with following LRI.)



SARERRST0 - SARB Error Status slice0

B/D/F/Type: 0/0/0/SARBunit_Confi
 g
Address Offset: B004-B007h
Default Value: 00000000h
Access: RO;
Size: 32 bits

Reports the error if any has occurred for certain sarb features.

This register is not ctx saved

Bit	Access	Default Value	RST/PWR	Description
31	RO	0b	Core	Error if general bound is zero (ERRGENBDZO): Error if general bound is zero set by sarbunit 1: general bound address is 0 sarbcf_csr_gen_bnd_zero_err
30	RO	0b	Core	Error if dynamic bound is zero (ERRDYDNZO): Error if dynamic bound is zero- set by sarbunit 0:no error 1: dynamic address is 0 sarbcf_csr_dyn_bnd_zero_err
29	RO	0b	Core	Reserved (RSVD):
28	RO	0b	Core	General Bound Check Overflow Error (GENBNDOVF): General Bound Check Overflow Error - set by sarbunit 1: overflow for general bound check sarbcf_csr_gen_bnd_ovflw_err
27	RO	0b	Core	Dynamic Bound Check Overflow Error (DYNBDOVF): Dynamic Bound Check Overflow Error -set by sarbunit 1: overflow for dynamic bound check sarbcf_csr_dyn_bnd_ovflw_err



Bit	Access	Default Value	RST/PWR	Description
26	RO	0b	Core	Lower Bound Check Overflow Error (LWRBDOVF): Lower Bound Check Overflow Error-set by sarbunit lower bound overflow sarbcf_csr_lower_bnd_err
25:21	RO	00000b	Core	INVALIDATION FLUSH STATUS REPORTING (INVSTRPT): invalidation status for I3 is reported in this register.
20:18	RO	000b	Core	SARB invalidation Status reporting (SARBINVSTRPT): invalidation status of sarb is reported in this register.
17	RO	0b	Core	HW surface Bound Check Overflow Error (HWSBDOVF): sarbcf_csr_hw_surf_bnd_ovflw_err HW Surface Bound Check Overflow Error -set by sarbunit 1: overflow for bound check
16	RO	0b	Core	Error if hw surface bound is zero (ERRHWSNZO): sarbcf_csr_hw_surf_bnd_zero_err Error if hw surface bound is zero- set by sarbunit 0:no error 1: address is 0
15	RO	0b	Core	buffer Ready intp err (INTPERR): When both buffers are ready before one buffer ready is cleared by sft sarb will generate intp err (it is not expected that second buffer ready should assert while first buffer ready was not cleared by sftwr.) sarbcf_both_buffer_rd_intp_err
14:0	RO	0000h	Core	Reserved (RSVD): Reserved



L3CDERRST01 - L3CD Error Status register 1 slice 0

B/D/F/Type: 0/0/0/SARBunit_Confi
 g
Address Offset: B008-B00Bh
Default Value: 00000080h
Access: RW; RO; WO;
Size: 32 bits

Bit	Access	Default Value	RST/PWR	Description
31:25	RO	0000000b	Core	Reserved (RSVD): Reserved
24:14	RWC	00000000000b	Core	Parity row address error (PRTYROWNUM): Data array address which has parity B1: Report the data array address which has the Error ltcd_sarb_parity_err_rownum[10:0] Once set by HW, it can be cleared only by MMIO Write of 1 to this register bit 13 .
13	RWC	0b	Core	Parity Error Valid (PRTYERRVLD): Parity Error valid Report the Parity Error ltcd_sarb_parity_err_valid Once set by HW, it can be cleared only by MMIO Write of 1 to this register bit 13 .
12:11	RWC	00b	Core	Parity error bank number (PRTYBNKNUM): bank number which has parity error Report the bank no. which has the Error ltcd_sarb_parity_err_banknum[1:0] Once set by HW, it can be cleared only by MMIO Write of 1 to this register bit 13 .



Bit	Access	Default Value	RST/PWR	Description
10:8	RWC	000b	Core	Parity Error sub-bank no (PRTYSBNKNUM): Parity Error in sub bank: Itcd0_sarb_parity_err_subbanknum[2:0] Once set by HW, it can be cleared only by MMIO Write of 1 to this register bit 13 .
7	RW	1b	Core	Parity report enable (LCPRTYRPTEN): sarbcf_csr_lc_parity_report_en this is the parity reporting enable, by default it is enabled. When enabled by driver parity will be reported by Itcd to sarb. When disabled by driver, Itcd should not send out any parity error to SARB. this register bit is used by both slices
6:0	RO	00h	Core	Reserved (RSVD):



L3CDERRST02 - L3CD Error Status register 2 slice 0

B/D/F/Type: 0/0/0/SARBunit_Confi
 g
Address Offset: B00C-B00Fh
Default Value: 00000000h
Access: RO; RWC;
Size: 32 bits

Bit	Access	Default Value	RST/PWR	Description
31:29	RO	000b	Core	Reserved (RSVD): reserved
28	RWC	0b	Core	URB High Limit Error on B3 (URBHLB3): URB High Limit Error on B3: Report the URB High Limit Error- Address Bound check Once set, it can be cleared only by MMIO Write to this register. A write of value 1 will clear it (LTCC generates a Pulse to SARB Config , Sarb Config sets and reflect it in the MMIO as Error status. This can be only cleared by MMIO Write to that Bit.) Itcc3_sarb_urboff_error
27	RWC	0b	Core	URB High Limit Error on B2 (URBHLB2): URB High Limit Error on B2: Report the URB High Limit Error- Address Bound check Once set, it can be cleared only by MMIO Write to this register. (LTCC generates a Pulse to SARB Config , Sarb Config sets and reflect it in the MMIO as Error status. This can be only cleared by MMIO Write to that Bit.) Itcc2_sarb_urboff_error



Bit	Access	Default Value	RST/PWR	Description
26	RWC	0b	Core	URB High Limit Error on B1 (URBHLB1): URB High Limit Error on B1: Report the URB High Limit Error - Address Bound check Once set, it can be cleared only by MMIO Write to this register. (LTCC generates a Pulse to SARB Config , Sarb Config sets and reflect it in the MMIO as Error status. This can be only cleared by MMIO Write to that Bit.) ltcc1_sarb_urboff_error
25	RWC	0b	Core	URB High Limit Error on B0 (URBHLB0): URB High Limit Error on B0 : Report the URB High Limit Error - Address Bound check Once set, it can be cleared only by MMIO Write to this register. (LTCC generates a Pulse to SARB Config , Sarb Config sets and reflect it in the MMIO as Error status. This can be only cleared by MMIO Write to that Bit.) ltcc0_sarb_urboff_error
24:0	RO	0000000h	Core	Reserved (RSVD):



L3SQCREG1 - L3 SQC registers 1

B/D/F/Type: 0/0/0/SARBunit_Confi
 g
Address Offset: B010-B013h
Default Value: 01610000h
Access: RW; RO;
Size: 32 bits

Bit	Access	Default Value	RST/PWR	Description
31:28	RO	0000b	Core	Reserved (RSVD): Reserved
27	RW	0b	Core	Convert L3 cycle for texture to uncachable (CON4TXTUNC): Convert L3 cycle for texture to uncachable 1: texture has no way allocation in L3 0: texture has atleast 1 way allocated in L3 (default) sarbcf_csr_lsqc_cnvt_txt_unchble
26	RW	0b	Core	Convert L3 cycle for constant to uncachable (CON4CONSUNC): Convert L3 cycle for constant to uncachable 1: constant has no way allocation in L3 0: constant has atleast 1 way allocated in L3 (default) sarbcf_csr_lsqc_cnvt_const_unchble
25	RW	0b	Core	Convert L3 cycle for Inst/State to uncachable (CON4INSSTUNC): Convert L3 cycle for Inst/State to uncachable 1: Inst/State has no way allocation in L3 0: Inst/State has atleast 1 way allocated in L3 (default) sarbcf_csr_lsqc_cnvt_ins_st_unchble



Bit	Access	Default Value	RST/PWR	Description																																				
24	RW	1b	Core	<p>Convert L3 cycle for DC to uncachable (CON4DCUNC):</p> <p>Convert L3 cycle for DC to uncachable</p> <p>1: DC has no way allocation in L3 (default)</p> <p>0: DC has atleast 1 way allocated in L3</p> <p>sarbcf_csr_lsqc_cnvt_dc_unchble</p> <p>Note: This bit can not be set to "1" when atomics in L3 mode is enabled</p>																																				
23:19	RW	01100b	Core	<p>L3SQ General Priority Credit Initialization (SQGPCI):</p> <p>L3SQ General Priority Credit Initialization (SQGPCI):</p> <p>Number of general and high priority credits that SQ presents to L3 Arbiter blocks. This inherently also determines the depth of the SQ; reduce the number of credits and SQ will use fewer slots.</p> <p>Any value not listed here, is considered Reserved.</p> <p>gen priority credits is always greater than high priority credits</p> <table border="1"> <thead> <tr> <th>Value</th> <th># General Credits</th> </tr> </thead> <tbody> <tr><td>00000</td><td>0</td></tr> <tr><td>00001</td><td>2</td></tr> <tr><td>00010</td><td>4</td></tr> <tr><td>00011</td><td>6</td></tr> <tr><td>00100</td><td>8</td></tr> <tr><td>00101</td><td>10</td></tr> <tr><td>00110</td><td>12</td></tr> <tr><td>00111</td><td>14</td></tr> <tr><td>01000</td><td>16</td></tr> <tr><td>01001</td><td>18</td></tr> <tr><td>01010</td><td>20</td></tr> <tr><td>01011</td><td>22</td></tr> <tr><td>01100</td><td>24(default)</td></tr> <tr><td>01101</td><td>26</td></tr> <tr><td>01110</td><td>28</td></tr> <tr><td>01111</td><td>30</td></tr> <tr><td>10000</td><td>32</td></tr> </tbody> </table> <p>Other values are not possible</p> <p>Need to go upto 32 credits</p> <p>sarbcf_csr_lsqc_gen_credit_init[4:0]</p>	Value	# General Credits	00000	0	00001	2	00010	4	00011	6	00100	8	00101	10	00110	12	00111	14	01000	16	01001	18	01010	20	01011	22	01100	24(default)	01101	26	01110	28	01111	30	10000	32
Value	# General Credits																																							
00000	0																																							
00001	2																																							
00010	4																																							
00011	6																																							
00100	8																																							
00101	10																																							
00110	12																																							
00111	14																																							
01000	16																																							
01001	18																																							
01010	20																																							
01011	22																																							
01100	24(default)																																							
01101	26																																							
01110	28																																							
01111	30																																							
10000	32																																							



Bit	Access	Default Value	RST/PWR	Description
18:14	RW	00100b	Core	<p>L3SQ High Priority Credit Initialization (SQHPCI):</p> <p>L3SQ High Priority Credit Initialization (SQHPCI):</p> <p>Number of general and high priority credits that SQ presents to L3 Arbiter blocks. This inherently also determines the depth of the SQ; reduce the number of credits and SQ will use fewer slots.</p> <p>Any value not listed here, is considered Reserved.</p> <p>gen priority credits is always greater than high priority credits</p> <p>Value</p> <p>00000</p> <p>00001</p> <p>00010</p> <p>00011</p> <p>00100</p> <p>00101</p> <p>00110</p> <p>00111</p> <p>01000</p> <p>01001</p> <p>01010</p> <p>01011</p> <p>01100</p> <p>01101</p> <p>01110</p> <p>01111</p> <p>10000</p> <p>Other values are not possible</p> <p>sarbcf_csr_lsqc_hp_credit_init[4:0]</p> <p>sarbcf_csr_lsqc_hp_credit_init[4:0] ++</p> <p>sarbcf_csr_lsqc_gen_credit_init[4:0] should always be less than or equal to 32.</p>



Bit	Access	Default Value	RST/PWR	Description
13:12	RW	00b	Core	<p>L3SQ Atomics Credit Initialization (SQACI): L3SQ Atomics Credit Initialization (SQACI) Number of atomics credits that SQ presents to L3 Arbiter blocks. 00 = 2 Credits (default) 01 = 1 Credit 1X = Reserved sarbcf_csr_lsqc_atom_credit_init[1:0]</p>
11:10	RW	00b	Core	<p>L3SQ Data Credit Initialization (SQDCI): L3SQ Data Credit Initialization (SQDCI) Number of data credits that SQ presents to L3 Arbiter blocks. 00 = 4 Credits (default) 01 = 1 Credit 10 = 2 Credits 11 = 3 Credits sarbcf_csr_lsqc_data_credit_init[1:0]</p>
9	RW	0b	Core	<p>L3SQ Read Once Enable for Sampler Client (SQROE): L3SQ Read Once Enable for Sampler Client (SQROE): Enables Read Once indications to L3 Cache from SQ. Once enabled, any reads from Sampler client (MT) will be sent as Read Once 0 = Reads from Sampler clients issue Read to L3 Cache (default) 1 = Reads from Sampler clients issue Read Once to L3 Cache sarbcf_csr_sampler_readonce_en</p>



Bit	Access	Default Value	RST/PWR	Description
8:6	RW	000b	Core	<p>L3SQ Outstanding GAP Reads (SQOUTSGAP):</p> <p>L3SQ Outstanding GAP Reads (SQOUTSGAP):</p> <p>Identifies the number of Pixel Arbiter Reads that can be outstanding before SQ throttles the puts to GAP. This is not an exact limit, but instead it is used as a threshold to throttling; once the read count is greater than or equal to the threshold, then no reads will be issued until data returns are received to bring the outstanding count back below the threshold.</p> <p>000 = No limit (default) 001 = 2 read 010 = 3 reads 011 = 5 reads 100 = 9 reads 101 = 17 reads 11X = Reserved</p> <p>sarbcf_csr_lsqc_outs_gaprd[2:0]</p>
5:3	RW	000b	Core	<p>L3SQ Outstanding L3 Fills (SQOUTSL3F):</p> <p>L3SQ Outstanding L3 Fills (SQOUTSL3F):</p> <p>Identifies the number of L3 Fills that can be outstanding before SQ throttles the fill requests to L3 Cache. This is not an exact limit, but instead it is used as a threshold to throttling; once the fill count is greater than or equal to the threshold, then no fills will be issued until the fill responses are received to bring the outstanding count back below the threshold.</p> <p>000 = No limit (default) 001 = 1 fill 010 = 2 fills 011 = 4 fills 100 = 8 fills 101 = 16 fills 11X = Reserved</p> <p>sarbcf_csr_lsqc_outs_fill[2:0]</p>



Bit	Access	Default Value	RST/PWR	Description
2:0	RW	000b	Core	L3SQ Outstanding L3 Lookups (SQOUTSL3L): L3SQ Outstanding L3 Lookups (SQOUTSL3L): Identifies the number of L3 lookups that can be outstanding before SQ throttles the lookup requests to L3 Cache. This is not an exact limit, but instead it is used as a threshold to throttling; once the lookup count is greater than or equal to the threshold, then no lookups will be issued until the lookup responses are received to bring the outstanding count back below the threshold. 000 = No limit (default) 001 = 1 lookup 010 = 2 lookups 011 = 4 lookups 100 = 8 lookups 101 = 16 lookups 11X = Reserved sarbcf_csr_lsqc_outs_lookup[2:0]



L3SQCREG2 - L3 SQ registers 2

B/D/F/Type: 0/0/0/SARBunit_Confi
 g
Address Offset: B014-B017h
Default Value: 00004567h
Access: RO; RW;
Size: 32 bits

Bit	Access	Default Value	RST/PWR	Description
31:17	RO	0000000000000000b	Core	Reserved (RSVD): Reserved
16	RW	0b	Core	L3SQ Priority Selection Disable (SQPRIDIS): L3SQ Priority Selection Disable (SQPRIDIS) Enables the use of priority selection based on client ID decodes. If disabled, all cycles in SQ will be treated as same priority 0 = Priority selection is enabled (default) 1 = Priority selection is disabled sarbcf_csr_priority_cnt_disable
15	RW	0b	Core	L3SQ Priority 3 Pool Count Disable (SQPRI3CNTDIS): L3SQ Priority 3 Pool Count Disable (SQPRI3CNTDIS): When set, priority3 pool becomes unlimited. And priority3 pool count value should not be used in reset of the remaining counters. 0 = Priority 3 pool count is enabled (default) 1 = Priority 3 pool count is disabled sarbcf_csr_priority3_cnt_disable
14:12	RW	100b	Core	L3SQ Priority 3 Pool Counter (SQPRI3CNT): L3SQ Priority 3 Pool Counter (SQPRI3CNT): The count of cycles will be selected from priority3 pool before switching to other priority pools. Count is used as the power of 2. 000 = 1 request 001 = 2 requests 010 = 4 requests 011 = 8 requests



Bit	Access	Default Value	RST/PWR	Description
				.. 111 = 128 requests sarbcf_csr_priority3_cnt[2:0]
11	RW	0b	Core	L3SQ Priority 2 Pool Count Disable (SQPRI2CNTDIS): L3SQ Priority 2 Pool Count Disable (SQPRI2CNTDIS): When set, priority2 pool becomes unlimited. And priority2 pool count value should not be used in reset of the remaining counters. 0 = Priority 2 pool count is enabled (default) 1 = Priority 2 pool count is disabled sarbcf_csr_priority2_cnt_disable
10:8	RW	101b	Core	L3SQ Priority 2 Pool Counter (SQPRI2CNT): L3SQ Priority 2 Pool Counter (SQPRI2CNT): The count of cycles will be selected from priority2 pool before switching to other priority pools. Count is used as the power of 2. 000 = 1 request 001 = 2 requests 010 = 4 requests 011 = 8 requests .. 111 = 128 requests sarbcf_csr_priority2_cnt[2:0]
7	RW	0b	Core	L3SQ Priority 1 Pool Count Disable (SQPRI1CNTDIS): L3SQ Priority 1 Pool Count Disable (SQPRI1CNTDIS): When set, priority1 pool becomes unlimited. And priority1 pool count value should not be used in reset of the remaining counters. 0 = Priority 1 pool count is enabled (default) 1 = Priority 1 pool count is disabled sarbcf_csr_priority1_cnt_disable
6:4	RW	110b	Core	L3SQ Priority 1 Pool Counter (SQPRI1CNT): L3SQ Priority 1 Pool Counter (SQPRI1CNT): The count of cycles will be selected from priority1 pool before



Bit	Access	Default Value	RST/PWR	Description
				switching to other priority pools. Count is used as the power of 2. 000 = 1 request 001 = 2 requests 010 = 4 requests 011 = 8 requests .. 111 = 128 requests sarbcf_csr_priority1_cnt[2:0]
3	RW	0b	Core	L3SQ Priority 0 Pool Count Disable (SQPRI0CNTDIS): L3SQ Priority 0 Pool Count Disable (SQPRI0CNTDIS): When set, priority0 pool becomes unlimited. And priority0 pool count value should not be used in reset of the remaining counters. 0 = Priority 0 pool count is enabled (default) 1 = Priority 0 pool count is disabled sarbcf_csr_priority0_cnt_disable
2:0	RW	111b	Core	L3SQ Priority 0 Pool Counter (SQPRI0CNT): L3SQ Priority 0 Pool Counter (SQPRI0CNT): The count of cycles will be selected from priority0 pool before switching to other priority pools. Count is used as the power of 2. 000 = 1 request 001 = 2 requests 010 = 4 requests 011 = 8 requests .. 111 = 128 requests (default) sarbcf_csr_priority0_cnt[2:0]

L3SQCREG3 - L3 SQC registers 3

B/D/F/Type: 0/0/0/SARBunit_Confi
g
Address Offset: B018-B01Bh
Default Value: 00001ABFh



Access: RO; RW;

Size: 32 bits

Bit	Access	Default Value	RST/PWR	Description
31:30	RO	00b	Core	Reserved (RSVD): Reserved
29:28	RW	00b	Core	SOLunit Priority Value (SQSOLPRIVAL): SOLunit Priority Value (SQSOLPRIVAL): Identifies the priority value for all cycles that are initiated by SOLunit. Priority is used in the L3 Super Queue (L3SQ). 00 = Priority 0 (default) 01 = Priority 1 10 = Priority 2 11 = Priority 3 sarbcf_csr_sol_priority[1:0]
27:26	RW	00b	Core	GSunit Priority Value (SQGSPRIVAL): GSunit Priority Value (SQGSPRIVAL): Identifies the priority value for all cycles that are initiated by GSunit. Priority is used in the L3 Super Queue (L3SQ). 00 = Priority 0 (default) 01 = Priority 1 10 = Priority 2 11 = Priority 3 sarbcf_csr_gs_priority[1:0]
25:24	RW	00b	Core	TEunit Priority Value (SQTEPRIVAL): TEunit Priority Value (SQTEPRIVAL): Identifies the priority value for all cycles that are initiated by TEunit. Priority is used in the L3 Super Queue (L3SQ). 00 = Priority 0 (default) 01 = Priority 1 10 = Priority 2 11 = Priority 3



Bit	Access	Default Value	RST/PWR	Description
				sarbcf_csr_te_priority[1:0]
23:22	RW	00b	Core	<p>CLunit Priority Value (SQCLPRIVAL): CLunit Priority Value (SQCLPRIVAL): Identifies the priority value for all cycles that are initiated by CLunit. Priority is used in the L3 Super Queue (L3SQ). 00 = Priority 0 (default) 01 = Priority 1 10 = Priority 2 11 = Priority 3</p> <p>sarbcf_csr_cl_priority[1:0]</p>
21:20	RW	00b	Core	<p>TSunit Priority Value (SQTSPRIVAL): TSunit Priority Value (SQTSPRIVAL): Identifies the priority value for all cycles that are initiated by TSunit. Priority is used in the L3 Super Queue (L3SQ). 00 = Priority 0 (default) 01 = Priority 1 10 = Priority 2 11 = Priority 3</p> <p>sarbcf_csr_ts_priority[1:0]</p>
19:18	RW	00b	Core	<p>SFunit Priority Value (SQSFPRIVAL): SFunit Priority Value (SQSFPRIVAL): Identifies the priority value for all cycles that are initiated by SFunit. Priority is used in the L3 Super Queue (L3SQ). 00 = Priority 0 (default) 01 = Priority 1 10 = Priority 2 11 = Priority 3</p> <p>sarbcf_csr_sf_priority[1:0]</p>
17:16	RW	00b	Core	<p>SVSM Priority Value (SQSVMPRIVAL): SVSM Priority Value (SQSVMPRIVAL):</p>



Bit	Access	Default Value	RST/PWR	Description
				<p>Identifies the priority value for all cycles that are initiated by SVSM. Priority is used in the L3 Super Queue (L3SQ).</p> <p>00 = Priority 0 (default) 01 = Priority 1 10 = Priority 2 11 = Priority 3</p> <p>sarbcf_csr_svsm_priority[1:0]</p>
15:14	RW	00b	Core	<p>SARB Priority Value (SQSARBPRIVAL):</p> <p>SARB Priority Value (SQSARBPRIVAL):</p> <p>Identifies the priority value for all cycles that are initiated by State Arbiter (SARB). Priority is used in the L3 Super Queue (L3SQ).</p> <p>00 = Priority 0 (default) 01 = Priority 1 10 = Priority 2 11 = Priority 3</p> <p>sarbcf_csr_sarb_priority[1:0]</p>
13:12	RW	01b	Core	<p>SBE Priority Value (SQSBEPRIVAL):</p> <p>SBE Priority Value (SQSBEPRIVAL):</p> <p>Identifies the priority value for all cycles that are initiated by SBE. Priority is used in the L3 Super Queue (L3SQ).</p> <p>00 = Priority 0 01 = Priority 1 (default) 10 = Priority 2 11 = Priority 3</p> <p>sarbcf_csr_sbe_priority[1:0]</p>
11:10	RW	10b	Core	<p>IC\$ Priority Value (SQICPRIVAL):</p> <p>IC\$ Priority Value (SQICPRIVAL):</p> <p>Identifies the priority value for all cycles that are initiated by Instruction Cache (IC\$). Priority is used in the L3 Super Queue (L3SQ).</p> <p>00 = Priority 0 01 = Priority 1</p>



Bit	Access	Default Value	RST/PWR	Description
				10 = Priority 2 (default) 11 = Priority 3 sarbcf_csr_ic_priority[1:0]
9:8	RW	10b	Core	TDL Priority Value (SQTDLPRIVAL): TDL Priority Value (SQTDLPRIVAL): Identifies the priority value for all cycles that are initiated by TDL. Priority is used in the L3 Super Queue (L3SQ). 00 = Priority 0 01 = Priority 1 10 = Priority 2 (default) 11 = Priority 3 sarbcf_csr_tdl_priority[1:0]
7:6	RW	10b	Core	DCunit Priority Value (SQDCPRIVAL): DCunit Priority Value (SQDCPRIVAL): Identifies the priority value for all cycles that are initiated by DC. Priority is used in the L3 Super Queue (L3SQ). 00 = Priority 0 01 = Priority 1 10 = Priority 2 (default) 11 = Priority 3 sarbcf_csr_dc_priority[1:0]
5:4	RW	11b	Core	DAPR Priority Value (SQDAPRPRIVAL): DAPR Priority Value (SQDAPRPRIVAL): Identifies the priority value for all cycles that are initiated by DAPR. Priority is used in the L3 Super Queue (L3SQ). 00 = Priority 0 01 = Priority 1 10 = Priority 2 11 = Priority 3 (default) sarbcf_csr_dapr_priority[1:0]



Bit	Access	Default Value	RST/PWR	Description
3:2	RW	11b	Core	MTunit Priority Value (SQMTPRIVAL): MTunit Priority Value (SQMTPRIVAL): Identifies the priority value for all cycles that are initiated by Sampler (MT). Priority is used in the L3 Super Queue (L3SQ). 00 = Priority 0 01 = Priority 1 10 = Priority 2 11 = Priority 3 (default) sarbcf_csr_mt_priority[1:0]
1:0	RW	11b	Core	LSQCunit Priority Value (SQPRIVAL): LSQCunit Priority Value (SQPRIVAL): Identifies the priority value for all cycles that are initiated by Super Queue (L3 Evictions). Priority is used in the L3 Super Queue (L3SQ). 00 = Priority 0 01 = Priority 1 10 = Priority 2 11 = Priority 3 (default) sarbcf_csr_lsqc_priority[1:0]

L3CNTLREG1 - L3 Control Register1

B/D/F/Type: 0/0/0/SARBunit_Confi
 g
Address Offset: B01C-B01Fh
Default Value: 8C47FF80h
Access: RW; RO;
Size: 32 bits

Bit	Access	Default Value	RST/PWR	Description
31:28	RW	1000b	Core	Data Fifo Depth Control (DFIFODC): Data Fifo Depth Control (TS mode) Stall Control: POR is 1000b. Flexing for Hitting the stall Validation scenarios



Bit	Access	Default Value	RST/PWR	Description
				Maximum available setting for h/w is "1000", any higher setting will not be functional. sarbcf_csr_lc_datafifo_depth[3:0]
27:24	RW	1100b	Core	Data Clock off time (DCLKOFFT): Data Clock off time (DATACLKOFF): Data Clock off time - Data block is shut off after these many number of clocks programmed in this register bits. sarbcf_csr_lc_dataclkoff_time[3:0]
23:20	RW	0100b	Core	TAG CLK OFF TIME (TAGCLKOFF): TAG CLK OFF TIME (TAGCLKOFF): TAG Clock Off time. This is the time, which Clock gating Logic check before it turn off the clock. sarbcf_csr_lc_tagclkoff_time[3:0]
19	RW	0b	Core	L3 Aging Disable Bit (L3AGDIS): L3 Aging Disable Bit (L3AGDIS): Aging Disable sarbcf_csr_lc_agingdis
18:15	RW	1111b	Core	Fill aging (L3AGF): Fill aging (L3AGF): Aging Counter for Fill sarbcf_csr_lc_fill_aging_cnt[3:0]
14:11	RW	1111b	Core	Aging Counter for Read 1 Port (L3AGR1): Aging Counter for Read 1 Port (L3AGR1): Aging Counter for Read 1 Port sarbcf_csr_lc_rd1_aging_cnt[3:0]
10:7	RW	1111b	Core	L3 Aging Counter for R0 (L3AGR0): L3 Aging Counter for R0 (L3AGR0): Aging Counter for R0 Port sarbcf_csr_lc_rd0_aging_cnt[3:0]



Bit	Access	Default Value	RST/PWR	Description
6:3	RW	0000b	Core	Number of NOPs (L3NOP): Number of NOPs (L3NOP): Number of NOPs to be inserted between the Tag commands. sarbcf_csr_lc_num_nop[3:0]
2	RW	0b	Core	OP0/OP1 Disable (L3OPDIS): OP0/OP1 Disable (L3OPDIS): This bit is used to enable the feature of inserting the number of cycles between the tag pipeline operation. sarbcf_csr_lc_op0op1_disable
1	RW	0b	Core	L3 OP1 Disable Mode (L3OP1DIS): L3 OP1 Disable Mode (L3OP1DIS): OP1 in L3 can be disabled which means there will be one Command transferred to the Tag pipeline in 1X Domain sarbcf_csr_lc_op1_disable Note: If this bit is set Aging mode needs to be disabled as well.
0	RO	0b	Core	Reserved (RSVD): Reserved

L3CNTLREG2 - L3 Control Register2

The following register has GT2 sizes as given and GT1 sizes in parenthesis.

GT3 sizes will be always 2X the GT2 sizes listed (i.e. if 000001: 8KB (4KB for GT1) for GT3 it will be 16KB).

B/D/F/Type: 0/0/0/SARBunit_Confi
g

Address Offset: B020-B023h

Default Value: 00080040h

Access: RW; RO;

Size: 32 bits

Bit	Access	Default Value	RST/PWR	Description
-----	--------	---------------	---------	-------------



Bit	Access	Default Value	RST/PWR	Description
31:28	RO	0000b	Core	Reserved (RSVD):
27	RW	0b	Core	DC way assignment SLM Behavior (DCWASLMB): DC way assignment SLM Behavior: In shared local memory mode DC is assigned into low b/w mode which requires it to be assigned non-matched ways of bigger banks and it will be hashed to 2 banks. sarbcf_csr_dc_slm_lowbw
26:21	RW	000000b	Core	DC Way Assignment (DCWASS): DC Way Assignment: Number of ways allocated for DC. Note this allocation is only for DC data types. 000000: 0KB 000001: 8KB (4KB for GT1, 16KB for GT3) 000010: 16KB (8KB for GT1, 32KB for GT3) 111111: 504KB (252KB for GT1, 1008KB for GT3) Note: This field must be 0KB is All L3 Client Pool is non-zero. sarbcf_csr_dc_size[5:0]
20	RW	0b	Core	RO Client Pool SLM Behavior (ROCPSLMB): RO Client Pool SLM Behavior: In shared local memory mode Read Only Clients are assigned into low b/w mode which requires it to be assigned non-matched ways of bigger banks and it will be hashed to 2 banks. sarbcf_csr_ro_slm_lowbw
19:14	RW	100000b	Core	Read Only Client Pool (RDOCPL): Read Only Client Pool: Number of ways allocated for ROnly L3 clients. This is a combined pool for all RO clients. In GT2 it is represented in terms of 8KB and GT1 it is represented in terms of 4KB. 000000: 0KB 000001: 8KB (4KB for GT1, 16KB for GT3) 000010: 16KB (8KB for GT1, 32KB for GT3) 111111: 504KB (252KB for GT1, 1008KB for GT3) Note: If all ROClient pool is non-zero, than Inst/state, Const and Texture client allocation should have 0KB allocation.



Bit	Access	Default Value	RST/PWR	Description
				sarbcf_csr_ro_size[5:0]
13:8	RO	000000b	Core	RSVD (RSVD):
7	RW	0b	Core	URB SLM Behavior (URBSLMB): URB SLM Behavior: In shared local memory mode URB is assigned into low b/w mode which requires it to be assigned non-matched ways of bigger banks and it will be hashed to 2 banks. sarbcf_csr_urb_slm_lowbw
6:1	RW	100000b	Core	URB Allocation (URBALL): URB Allocation: Number of ways allocated for URB usage 000000: 0KB 000001: 8KB (4KB for GT1, 16KB for GT3) 000010: 16KB (8KB for GT1, 32KB for GT3) 111111: 504KB (252KB for GT1, 1008 KB for GT3) sarbcf_csr_urb_size[5:0]
0	RW	0b	Core	SLM Mode Enable (SLMMENB): SLM Mode Enable: When enabled, a 128KB region of L3 is reserved for SLM. This allocation is done on 2 banks with 64KB per half-slice. 0: SLM is disabled 1: SLM is enabled Note: For GT1, there is only one 64KB allocation for single half-slice. sarbcf_csr_slm_mode

L3CNTLREG3 - L3 Control Register3

B/D/F/Type: 0/0/0/SARBunit_Confi
g

Address Offset: B024-B027h

Default Value: 00000000h

Access: RO; RW;

Size: 32 bits



Bit	Access	Default Value	RST/PWR	Description
31:22	RO	0000000000b	Core	Reserved (RSVD):
21	RW	0b	Core	Textures Way Allocation SLM Behavior (TWASLMB): Textures Way Allocation SLM Behavior: In shared local memory mode Textures is assigned into low b/w mode which requires it to be assigned non-matched ways of bigger banks and it will be hashed to 2 banks. sarbcf_csr_tex_slm_lowbw
20:15	RW	000000b	Core	Textures Way Allocation (TXWYALL): Textures Way Allocation: Number of ways allocated for Textures. In GT2 it is represented interms of 8KB and GT1 it is represented interms of 4KB 000000: 0KB 000001: 8KB (4KB for GT1, 16KB for GT3) 000010: 16KB (8KB for GT1, 32KB for GT3) 111111: 504KB (252KB for GT1, 1004KB for GT3) Note: This field must be 0KB is All L3 Client Pool or Read-Only Client Pool is non-zero. sarbcf_csr_tex_size[5:0]
14	RW	0b	Core	Constants Way Allocation SLM Behavior (CWASLMB): Constants Way Allocation SLM Behavior: In shared local memory mode Instruction/state is assigned into low b/w mode which requires it to be assigned non-matched ways of bigger banks and it will be hashed to 2 banks. sarbcf_csr_const_slm_lowbw
13:8	RW	000000b	Core	Constants Way Allocation (CTWALL): Constants Way Allocation: Number of ways allocated for Constants. In GT2 it is represented interms of 8KB and GT1 it is represented interms of 4KB 000000: 0KB 000001: 8KB (4KB for GT1, 16KB for GT3) 000010: 16KB (8KB for GT1, 32KB for GT3) 111111: 504KB (252KB for GT1, 1004KB for GT3)



Bit	Access	Default Value	RST/PWR	Description
				Note: This field must be 0KB is All L3 Client Pool or Read-Only Client Pool is non-zero. sarbcf_csr_const_size[5:0]
7	RW	0b	Core	Instruction/State Way Allocation SLM Behavior (ISWASLMB): Instruction/State Way Allocation SLM Behavior: In shared local memory mode Instruction/state is assigned into low b/w mode which requires it to be assigned non-matched ways of bigger banks and it will be hashed to 2 banks. sarbcf_csr_is_slm_lowbw
6:1	RW	000000b	Core	Instruction/State Way Allocation (ISWYALL): Instruction/State Way Allocation: Number of ways allocated for Instruction/State usage In GT2 it is represented interms of 8KB and GT1 it is represented interms of 4KB 000000: 0KB 000001: 8KB (4KB for GT1, 16KB for GT3) 000010: 16KB (8KB for GT1, 32KB for GT3) 111111: 504KB (252KB for GT1, 1008KB for GT3) Note: This field must be 0KB is All L3 Client Pool or Read-Only Client Pool is non-zero. sarbcf_csr_is_size[5:0]
0	RO	0b	Core	Reserved (RSVD): Reserved

L3SLMREG - L3 SLM Register

B/D/F/Type: 0/0/0/SARBunit_Confi
g
Address Offset: B028-B02Bh
Default Value: 40000000h
Access: RO; RW;
Size: 32 bits

Bit	Access	Default Value	RST/PWR	Description
-----	--------	---------------	---------	-------------



Bit	Access	Default Value	RST/PWR	Description
31	RW	0b	Core	Disable Periodic SLM/SQ slot allocation (DPSLMALL): Disable Periodic SLM/SQ slot allocation: When <code>cfg_Islm_livelock_fairarb_dis=1</code> Islm unit will always have the higher priority and <code>Islm_Isqc_block</code> to <code>Isqcunit</code> is asserted as long as there are requests in SLM FIFO <code>sarbcf_csr_Islm_livelock_fairarb_dis</code>
30:26	RW	10000b	Core	LSLM_SQ_PENDING_MAX (LSLMSQPEND): If Islmunit has read data to be sent to lcbunit this cfg register specifies the maximum number of clocks for which LSLMunit can block SQ request from being sent o lcbunit Default value = 8 <code>sarbcf_csr_Islm_sqpend_max[4:0]</code>
25	RW	0b	Core	LSLM address disable (LSLMADDDIS): 0- Enable b2b addr maching fix. Islmunit shouldnt block the cycle in fifo if there is a match in the pipeline 1- Disbale b2b addr maching fix. Islmunit should block the cycle in fifo if there is a match in the pipeline <code>sarbcf_csr_Islm_same_addr_dis</code> default =0
24:0	RO	0000000h	Core	Reserved (RSVD):

GARBCNTLREG - Arbiter Control Register

B/D/F/Type: 0/0/0/SARBunit_Confi
 g
Address Offset: B02C-B02Fh
Default Value: 29124500h
Access: RW; RO;
Size: 32 bits

Bit	Access	Default Value	RST/PWR	Description
31				



Bit	Access	Default Value	RST/PWR	Description
30	RW	0b	Core	<p>Disables hashing function (DISHHF):</p> <p>Disables hashing function to generate bank_id[1:0] for L3\$ bank accessing, and forces the use of address[7:6] for bank_id[1:0].</p> <p>0 : (default) Hash function enabled to generate L3\$ bank IDs.</p> <p>1 : L3\$ address[7:6] used as L3\$ bank IDs.</p> <p>sarbcf_csr_l3bankidhashdis</p>
29:28	RW	10b	Core	<p>Arbitration priority order between RCC and MSC (APORM):</p> <p>Arbitration priority order between RCC and MSC.</p> <p>00/11: Invalid; default setting used</p> <p>10 : Default setting; RCC < MSC (i.e., MSC has higher priority)</p> <p>01: RCC > MSC (i.e., RCC has higher priority)</p> <p>sarbcf_csr_rcc_msc_pri[1:0]</p>
27:22	RW	100100b	Core	<p>Arbitration priority order between RCZ, STC, and HIZ (APORSH):</p> <p>Arbitration priority order between RCZ, STC, and HIZ.</p> <p>100100 : Default setting; RCZ < STC < HIZ (i.e., RCZ has lowest priority; HIZ has highest priority)</p> <p>100001 : RCZ < HIZ < STC</p> <p>011000 : STC < RCZ < HIZ</p> <p>010010 : STC < HIZ < RCZ</p> <p>001001 : HIZ < RCZ < STC</p> <p>000110 : HIZ < STC < RCZ</p> <p>Note: Others settings are invalid, and result in use of default.</p> <p>sarbcf_csr_rcz_stc_hiz_pri[5:0]</p>
21:19	RW	010b	Core	<p>Write data port arbitration priority between Z client writes and L3\$ evictions (WDPAGAPZ):</p> <p>Z Max Write Request Limit Count (GFXC_MRLC):</p> <p>This is the MAX number of Allowed Requests Count - These counters keep track of the accepted requests from each engine. Requests are counted, regardless of kind of cycle (both Slice 0 and1). Minimum count value must be = 1</p> <p>sarbcf_csr_wdpagapz[2:0]</p>



Bit	Access	Default Value	RST/PWR	Description
18:16	RW	010b	Core	<p>Write data port arbitration priority between C client writes and Z/L3\$ writes/evictions (WDPAGAPC):</p> <p>C Max Request Limit Count (GFXZ_MRLC):</p> <p>This is the MAX number of Allowed Requests Count - These counters keep track of the accepted requests from each engine. Requests are counted, regardless of kind of cycle (both Slice 0 and1). Minimum count value must be = 1</p> <p>sarbcf_csr_wdpagapc[2:0]</p>
15				
14:12	RW	100b	Core	<p>L3 Max Write Request Limit Count (GFXL3):</p> <p>L3 Max Write Request Limit Count (GFXL3_MRLC):</p> <p>This is the MAX number of Allowed Requests Count - These counters keep track of the accepted requests from each engine. Requests are counted, regardless of kind of cycle (Miss/Hit/Present). Minimum count value must be = 1</p> <p>sarbcf_csr_wdpagap3[2:0]</p>
11:9	RW	010b	Core	<p>Vebox Max Request Limit Count (VEBOX):</p> <p>Vebox Max Request Limit Count (VEBOX_MRLC):</p> <p>This is the MAX number of Allowed Requests Count - These counters keep track of the accepted requests from each engine. Requests are counted, regardless of kind of cycle (both Slice 0 and1). Minimum count value must be = 1</p> <p>sarbcf_csr_wdpagapv[2:0]</p>
8	RW	1b	Core	<p>GAPs_fixarb_en (GAPSFYABEN):</p> <p>Arbitration order adjustment</p> <p>sarbcf_csr_gaps_fixarb_en</p>
7:0	RO	00h	Core	Reserved (RSVD):

L3SQCREG4 - L3 SQC register 4

B/D/F/Type: 0/0/0/SARBunit_Confi
g

Address Offset: B034-B037h



Default Value: 08000000h
Access: RWHC; RO; RW;
Size: 32 bits

Bit	Access	Default Value	RST/PWR	Description
31	RO	0b	Core	Reserved (RSVD):
30	RO	0b	Core	Reserved (RSVD):
29:28	RO	00b	Core	Reserved (RSVD):
27	RW	1b	Core	<p>L3SQ URB Read CAM Match Disable (SQURBRDCAMDIS):</p> <p>L3SQ URB Read CAM Match Disable (SQURBRDCAMDIS):</p> <p>Disables the L3SQ Cam Match ability for URB Reads. By disabling, this allows a performance mode where URB reads are not dependent upon one another but only on any previous URB writes to the same address. This allows many URB reads to the same cacheline at any given time instead of serializing the requests.</p> <p>1 = URB Read CAM matching is disabled; multiple URB reads to the same cacheline are allowed to be concurrent(default)</p> <p>0 = URB Read CAM matching is enabled; multiple URB reads to the same cacheline are serialized</p>
26	RWHC	0b	Core	<p>LSQC reset fcount (LSQCRFCNT):</p> <p>self clearing register bit - Write to this register generates 1 clock pulse sarbcf_csr_lsqc_rst_fcount to lsqc and also used to clear the register sarbcf_csr_lsqc_rst_fcount_lvl is output of configdb.</p>
25:0	RO	0000000h	Core	reserved (RSVD):

SCRATCH1 - SCRATCH1

B/D/F/Type: 0/0/0/SARBunit_Confi
g
Address Offset: B038-B03Bh
Default Value: 00000000h
Access: RW;
Size: 32 bits



Bits	Access	Default Value	RST/PWR	Description
31	RW	0b	Core	Reserved
30	R/W	0b	Core	<p>RO Serialization Disable:</p> <p>For 3D benchmarks, L3 introduced an optimization on B-step to enable back-to-back reads to the same RO space to streamline rather than waiting for each other to complete. This is a crucial performance fix.</p> <p>0: Enable optimization 1: Disable optimization</p> <p>NOTE:</p> <p><i>With RO serialization enabled, the following restrictions need to be followed:</i></p> <ul style="list-style-type: none"> - priority selection should not be disabled (don't set bit 16,15, 11,7,3) in L3SQCREG2 (0xb012). Keep the default value. - don't disable aging (don't set bit 19) in L3CNTLREG1 (0xb01c). Keep the default value.
29	RW	0b	Core	<p>RW Space Serialization Disable:</p> <p>For 3D benchmarks, L3 introduced as an optimization on B-step to enable back-to-back reads to the same RW space to streamline rather than waiting for each other to complete. This is a crucial performance fix.</p> <p>0: Enable optimization 1: Disable optimization</p>
28	RW	0b	Core	<p>Enable bank hanging for parity error.</p> <p>0: disable bank hanging 1:enable bank hanging</p>
27	RW	0b	Core	<p>Disable data atomic in L3</p> <p>0: enable data atomic in L3 1:disable data atomic in L3</p>
26:19	RW	000000000b	Core	SCRATCH (SCRATCH):
18:4	RW	0b	Core	Sub-Bank & Row selection for error injection



Bits	Access	Default Value	RST/PWR	Description
				<u>Non-SLM configuration</u> Bit 18: unused Bits 17:7: Row address Bits 6:4: Sub-Bank number <u>SLM configuration</u> Bits 18:7: Row address Bits 6:4: Sub-Bank number
3:2	RW	0b	Core	Bank ID for error injection 00b: Inject in Bank 0 01b: Inject in Bank 1 10b: Inject in Bank 2 11b: reserved – error injection not supported for SLM bank3.
1	RW	0b	Core	Slice ID for Error injection 0: Inject error in Slice 0 1: Inject error in Slice 1
0	RW	0b	Core	Parity Error Injection Enable 0: Disable parity error injection 1: Enable parity error injection

LTIOREG - LTIO Register

B/D/F/Type: 0/0/0/SARBunit_Confi
 g
Address Offset: B03C-B03Fh
Default Value: 00000086h
Access: RW; RO;
Size: 32 bits

Bit	Access	Default Value	RST/PWR	Description
31	RW	0b	Core	LTIO Arb Mode (LTIOARBM): 0- default- optimized arbitraion



Bit	Access	Default Value	RST/PWR	Description
				1- simple arbitraion sarbcf_csr_ltio_arb_mode
30	RW	0b	Core	LTIO FCOUNT SEL (LTIOFSEL): 0-default - pick hardware synchronized 1- pick static fcount from sarb sarbcf_csr_ltio_fcount_sel
29	RO	0b	Core	Reserved (RSVD):
28:24	RW	00000b	Core	FCOUNT (FCNT): Fcount sarbcf_csr_ltio_fcount[4 :0]
23:8	RO	0000h	Core	Reserved (RSVD):
7:4	RW	1000b	Core	LTIO WaterMark High (LTIOWMKH):
3:0	RW	0110b	Core	LTIO WaterMark Low (LTIOWMKL):

CLMREDS0 - Column Redundancy Slice 0

B/D/F/Type: 0/0/0/SARBunit_Confi
g
Address Offset: B044-B047h
Default Value: 00000000h
Access: RW; RO;
Size: 32 bits

This register is written by mbcunit and is not ctx saved

Bit	Access	Default Value	RST/PWR	Description
31:25	RW	00h	Core	column redundancy bank 0 (CRB0): sarb_ltc0_fuse[6:0]
24:18	RW	00h	Core	Column Redundancy bank1 (CRB1): sarb_ltc1_fuse[6:0]
17:11	RW	00h	Core	column redundancy bank 2 (CRB2): sarb_ltc2_fuse[6:0]
10:4	RW	00h	Core	column redundancy bank 3 (CRB3): sarb_ltc3_fuse[6:0]



Bit	Access	Default Value	RST/PWR	Description
3:0	RO	0000b	Core	Reserved (RSVD):

LPCNTR1S0 - LPFC counter reg01 slice 0

B/D/F/Type: 0/0/0/SARBunit_Confi
g
Address Offset: B04C-B04Fh
Default Value: 00000000h
Access: RO;
Size: 32 bits

Counter 0

Bit	Access	Default Value	RST/PWR	Description
31:0	RO	00000000h	Core	LPFC Counter 1 slice 0 (LPFCNT01): Counter 1

LPCNTR2S0 - LPFC counter reg02 slice 0

B/D/F/Type: 0/0/0/SARBunit_Confi
g
Address Offset: B050-B053h
Default Value: 00000000h
Access: RO;
Size: 32 bits

Bit	Access	Default Value	RST/PWR	Description
31:0	RO	00000000h	Core	LPFC Counter 2 slice 0 (LPFCNT02): Counter2

LPCNTR3S0 - LPFC counter reg03 slice 0

B/D/F/Type: 0/0/0/SARBunit_Confi
g
Address Offset: B054-B057h
Default Value: 00000000h
Access: RO;
Size: 32 bits

Bit	Access	Default Value	RST/PWR	Description
-----	--------	---------------	---------	-------------



Bit	Access	Default Value	RST/PWR	Description
31:0	RO	00000000h	Core	LPFC Counter 3 slice 0 (LPFCCNT03): Counter3

LPCNTR4S0 - LPFC counter reg04 slice 0

B/D/F/Type: 0/0/0/SARBunit_Confi
g
Address Offset: B058-B05Bh
Default Value: 00000000h
Access: RO;
Size: 32 bits

Bit	Access	Default Value	RST/PWR	Description
31:0	RO	00000000h	Core	LPFC Counter 4 slice 0 (LPFCCNT04): Counter4

LPCNTR5S0 - LPFC counter reg05 slice 0

B/D/F/Type: 0/0/0/SARBunit_Confi
g
Address Offset: B05C-B05Fh
Default Value: 00000000h
Access: RO;
Size: 32 bits

Bit	Access	Default Value	RST/PWR	Description
31:0	RO	00000000h	Core	LPFC Counter 5 slice 0 (LPFCCNT05): Counter5

LPCNTR6S0 - LPFC counter reg06 slice 0

B/D/F/Type: 0/0/0/SARBunit_Confi
g
Address Offset: B060-B063h
Default Value: 00000000h
Access: RO;
Size: 32 bits

Bit	Access	Default Value	RST/PWR	Description
31:0	RO	00000000h	Core	LPFC Counter 6 slice 0 (LPFCCNT06):



Bit	Access	Default Value	RST/PWR	Description
				Counter6

LPCNTR7S0 - LPFC counter reg07 slice 0

B/D/F/Type: 0/0/0/SARBunit_Confi
g
Address Offset: B064-B067h
Default Value: 00000000h
Access: RO;
Size: 32 bits

Bit	Access	Default Value	RST/PWR	Description
31:0	RO	00000000h	Core	LPFC Counter 7 slice 0 (LPFCNT07): Counter7

LPCNTR8S0 - LPFC counter reg08 slice 0

B/D/F/Type: 0/0/0/SARBunit_Confi
g
Address Offset: B068-B06Bh
Default Value: 00000000h
Access: RO;
Size: 32 bits

Bit	Access	Default Value	RST/PWR	Description
31:0	RO	00000000h	Core	LPFC Counter 8 slice 0 (LPFCNT08): Counter8

L3B0REG00 - L3 bank0 reg0 log error slice 0

B/D/F/Type: 0/0/0/SARBunit_Confi
g
Address Offset: B070-B073h
Default Value: 00000000h
Access: WO; RO;
Size: 32 bits

The ERROR LOG registers of L3 will maintain the bad row information for each of the 16KB subbank groups. The LOG will be programmed by driver before any workloads are submitted.

The contents of the LOG register will be context Save&Restored by h/w around rc6 events.



Bit	Access	Default Value	RST/PWR	Description
31:21	WO	000h	Core	<p>Row Number for Error1 (RNUMERR1):</p> <p>Row Number for Error1:</p> <p>The physical row number where the parity error has been detected. The number of rows vary between 4K vs 8K/16K subbanks which requires 10bits vs 11bits respectively.</p> <p>This field contains the row# with the error</p>
20:17	RO	0000b	Core	<p>Reserved (RSVD):</p>
16	WO	0b	Core	<p>Valid Error 1 (VLDERR1):</p> <p>Valid Error:</p> <p>The error located in field 15:5 is valid and corresponding logical 16KB group should bypass this row.</p>
15:5	WO	000h	Core	<p>Row Number for Error0 (RNUMERR0):</p> <p>Row Number for Error0:</p> <p>The physical row number where the parity error has been detected. The number of rows vary between 4K vs 8K/16K subbanks which requires 10bits vs 11bits respectively.</p> <p>This field contains the row# with the error</p>
4:1	RO	0000b	Core	<p>Reserved (RSVD):</p>
0	WO	0b	Core	<p>Valid Error 0 (VLDERR0):</p> <p>Valid Error:</p> <p>The error located in field 15:5 is valid and corresponding logical 16KB group should bypass this row.</p>

L3B0REG01 - L3 bank0 reg1 log error slice 0

B/D/F/Type: 0/0/0/SARBunit_Config
Address Offset: B074-B077h
Default Value: 00000000h
Access: WO; RO;
Size: 32 bits



The ERROR LOG registers of L3 will maintain the bad row information for each of the 16KB subbank groups. The LOG will be programmed by driver before any workloads are submitted.

The contents of the LOG register will be context Save&Restored by h/w around rc6 events.

Bit	Access	Default Value	RST/PWR	Description
31:21	WO	000h	Core	Row Number for Error1 (RNUMERR1): Row Number for Error1: The physical row number where the parity error has been detected. The number of rows vary between 4K vs 8K/16K subbanks which requires 10bits vs 11bits respectively. This field contains the row# with the error
20:17	RO	0000b	Core	Reserved (RSVD):
16	WO	0b	Core	Valid Error 1 (VLDERR1): Valid Error: The error located in field 15:5 is valid and corresponding logical 16KB group should bypass this row.
15:5	WO	000h	Core	Row Number for Error0 (RNUMERR0): Row Number for Error0: The physical row number where the parity error has been detected. The number of rows vary between 4K vs 8K/16K subbanks which requires 10bits vs 11bits respectively. This field contains the row# with the error
4:1	RO	0000b	Core	Reserved (RSVD):
0	WO	0b	Core	Valid Error 0 (VLDERR0): Valid Error: The error located in field 15:5 is valid and corresponding logical 16KB group should bypass this row.

L3B0REG02 - L3 bank0 reg2 log error slice 0

B/D/F/Type: 0/0/0/SARBunit_Confi
 g
Address Offset: B078-B07Bh
Default Value: 00000000h



Access: WO; RO;

Size: 32 bits

The ERROR LOG registers of L3 will maintain the bad row information for each of the 16KB subbank groups. The LOG will be programmed by driver before any workloads are submitted.

The contents of the LOG register will be context Save&Restored by h/w around rc6 events.

Bit	Access	Default Value	RST/PWR	Description
31:21	WO	000h	Core	Row Number for Error1 (RNUMERR1): Row Number for Error1: The physical row number where the parity error has been detected. The number of rows vary between 4K vs 8K/16K subbanks which requires 10bits vs 11bits respectively. This field contains the row# with the error
20:17	RO	0000b	Core	Reserved (RSVD):
16	WO	0b	Core	Valid Error 1 (VLDERR1): Valid Error: The error located in field 15:5 is valid and corresponding logical 16KB group should bypass this row.
15:5	WO	000h	Core	Row Number for Error0 (RNUMERR0): Row Number for Error0: The physical row number where the parity error has been detected. The number of rows vary between 4K vs 8K/16K subbanks which requires 10bits vs 11bits respectively. This field contains the row# with the error
4:1	RO	0000b	Core	Reserved (RSVD):
0	WO	0b	Core	Valid Error 0 (VLDERR0): Valid Error: The error located in field 15:5 is valid and corresponding logical 16KB group should bypass this row.

L3B0REG03 - L3 bank0 reg3 log error slice 0

B/D/F/Type: 0/0/0/SARBunit_Confi



Address Offset: g
 B07C-B07Fh
Default Value: 00000000h
Access: WO; RO;
Size: 32 bits

The ERROR LOG registers of L3 will maintain the bad row information for each of the 16KB subbank groups. The LOG will be programmed by driver before any workloads are submitted.

The contents of the LOG register will be context Save&Restored by h/w around rc6 events.

Bit	Access	Default Value	RST/PWR	Description
31:21	WO	000h	Core	Row Number for Error1 (RNUMERR1): Row Number for Error1: The physical row number where the parity error has been detected. The number of rows vary between 4K vs 8K/16K subbanks which requires 10bits vs 11bits respectively. This field contains the row# with the error
20:17	RO	0000b	Core	Reserved (RSVD):
16	WO	0b	Core	Valid Error 1 (VLDERR1): Valid Error: The error located in field 15:5 is valid and corresponding logical 16KB group should bypass this row.
15:5	WO	000h	Core	Row Number for Error0 (RNUMERR0): Row Number for Error0: The physical row number where the parity error has been detected. The number of rows vary between 4K vs 8K/16K subbanks which requires 10bits vs 11bits respectively. This field contains the row# with the error
4:1	RO	0000b	Core	Reserved (RSVD):
0	WO	0b	Core	Valid Error 0 (VLDERR0): Valid Error: The error located in field 15:5 is valid and corresponding logical 16KB group should bypass this row.



L3B0REG04 - L3 bank0 reg4 log error slice0

B/D/F/Type: 0/0/0/SARBunit_Confi
 g
Address Offset: B080-B083h
Default Value: 00000000h
Access: WO; RO;
Size: 32 bits

The ERROR LOG registers of L3 will maintain the bad row information for each of the 16KB subbank groups. The LOG will be programmed by driver before any workloads are submitted.

The contents of the LOG register will be context Save&Restored by h/w around rc6 events.

Bit	Access	Default Value	RST/PWR	Description
31:21	WO	000h	Core	Row Number for Error1 (RNUMERR1): Row Number for Error1: The physical row number where the parity error has been detected. The number of rows vary between 4K vs 8K/16K subbanks which requires 10bits vs 11bits respectively. This field contains the row# with the error
20:17	RO	0000b	Core	Reserved (RSVD):
16	WO	0b	Core	Valid Error 1 (VLDERR1): Valid Error: The error located in field 15:5 is valid and corresponding logical 16KB group should bypass this row.
15:5	WO	000h	Core	Row Number for Error0 (RNUMERR0): Row Number for Error0: The physical row number where the parity error has been detected. The number of rows vary between 4K vs 8K/16K subbanks which requires 10bits vs 11bits respectively. This field contains the row# with the error
4:1	RO	0000b	Core	Reserved (RSVD):
0	WO	0b	Core	Valid Error 0 (VLDERR0): Valid Error:



Bit	Access	Default Value	RST/PWR	Description
				The error located in field 15:5 is valid and corresponding logical 16KB group should bypass this row.

L3B0REG05 - L3 bank0 reg5 log error slice0

B/D/F/Type: 0/0/0/SARBunit_Confi
g

Address Offset: B084-B087h

Default Value: 00000000h

Access: WO; RO;

Size: 32 bits

The ERROR LOG registers of L3 will maintain the bad row information for each of the 16KB subbank groups. The LOG will be programmed by driver before any workloads are submitted.

The contents of the LOG register will be context Save&Restored by h/w around rc6 events.

Bit	Access	Default Value	RST/PWR	Description
31:21	WO	000h	Core	Row Number for Error1 (RNUMERR1): Row Number for Error1: The physical row number where the parity error has been detected. The number of rows vary between 4K vs 8K/16K subbanks which requires 10bits vs 11bits respectively. This field contains the row# with the error
20:17	RO	0000b	Core	Reserved (RSVD):
16	WO	0b	Core	Valid Error 1 (VLDERR1): Valid Error: The error located in field 15:5 is valid and corresponding logical 16KB group should bypass this row.
15:5	WO	000h	Core	Row Number for Error0 (RNUMERR0): Row Number for Error0: The physical row number where the parity error has been detected. The number of rows vary between 4K vs 8K/16K subbanks which requires 10bits vs 11bits respectively. This field contains the row# with the error



Bit	Access	Default Value	RST/PWR	Description
4:1	RO	0000b	Core	Reserved (RSVD):
0	WO	0b	Core	Valid Error 0 (VLDERR0): Valid Error: The error located in field 15:5 is valid and corresponding logical 16KB group should bypass this row.

L3B0REG06 - L3 bank0 reg6 log error slice 0

B/D/F/Type: 0/0/0/SARBunit_Confi
g

Address Offset: B088-B08Bh

Default Value: 00000000h

Access: WO; RO;

Size: 32 bits

The ERROR LOG registers of L3 will maintain the bad row information for each of the 16KB subbank groups. The LOG will be programmed by driver before any workloads are submitted.

The contents of the LOG register will be context Save&Restored by h/w around rc6 events.

Bit	Access	Default Value	RST/PWR	Description
31:21	WO	000h	Core	Row Number for Error1 (RNUMERR1): Row Number for Error1: The physical row number where the parity error has been detected. The number of rows vary between 4K vs 8K/16K subbanks which requires 10bits vs 11bits respectively. This field contains the row# with the error
20:17	RO	0000b	Core	Reserved (RSVD):
16	WO	0b	Core	Valid Error 1 (VLDERR1): Valid Error: The error located in field 15:5 is valid and corresponding logical 16KB group should bypass this row.
15:5	WO	000h	Core	Row Number for Error0 (RNUMERR0):



Bit	Access	Default Value	RST/PWR	Description
				<p>Row Number for Error0:</p> <p>The physical row number where the parity error has been detected. The number of rows vary between 4K vs 8K/16K subbanks which requires 10bits vs 11bits respectively.</p> <p>This field contains the row# with the error</p>
4:1	RO	0000b	Core	Reserved (RSVD):
0	WO	0b	Core	<p>Valid Error 0 (VLDERR0):</p> <p>Valid Error:</p> <p>The error located in field 15:5 is valid and corresponding logical 16KB group should bypass this row.</p>

L3B0REG07 - L3 bank0 reg7 log error slice0

B/D/F/Type: 0/0/0/SARBunit_Confi
g

Address Offset: B08C-B08Fh

Default Value: 00000000h

Access: WO; RO;

Size: 32 bits

The ERROR LOG registers of L3 will maintain the bad row information for each of the 16KB subbank groups. The LOG will be programmed by driver before any workloads are submitted.

The contents of the LOG register will be context Save&Restored by h/w around rc6 events.

Bit	Access	Default Value	RST/PWR	Description
31:21	WO	000h	Core	<p>Row Number for Error1 (RNUMERR1):</p> <p>Row Number for Error1:</p> <p>The physical row number where the parity error has been detected. The number of rows vary between 4K vs 8K/16K subbanks which requires 10bits vs 11bits respectively.</p> <p>This field contains the row# with the error</p>
20:17	RO	0000b	Core	Reserved (RSVD):
16	WO	0b	Core	Valid Error 1 (VLDERR1):



Bit	Access	Default Value	RST/PWR	Description
				Valid Error: The error located in field 15:5 is valid and corresponding logical 16KB group should bypass this row.
15:5	WO	000h	Core	Row Number for Error0 (RNUMERR0): Row Number for Error0: The physical row number where the parity error has been detected. The number of rows vary between 4K vs 8K/16K subbanks which requires 10bits vs 11bits respectively. This field contains the row# with the error
4:1	RO	0000b	Core	Reserved (RSVD):
0	WO	0b	Core	Valid Error 0 (VLDERR0): Valid Error: The error located in field 15:5 is valid and corresponding logical 16KB group should bypass this row.

L3B1REG00 - L3 bank1 reg0 log error slice 0

B/D/F/Type: 0/0/0/SARBunit_Config

Address Offset: B090-B093h

Default Value: 00000000h

Access: WO; RO;

Size: 32 bits

The ERROR LOG registers of L3 will maintain the bad row information for each of the 16KB subbank groups. The LOG will be programmed by driver before any workloads are submitted.

The contents of the LOG register will be context Save&Restored by h/w around rc6 events.

Bit	Access	Default Value	RST/PWR	Description
31:21	WO	000h	Core	Row Number for Error1 (RNUMERR1): Row Number for Error1: The physical row number where the parity error has been detected. The number of rows vary between 4K vs 8K/16K subbanks which requires 10bits vs 11bits respectively.



Bit	Access	Default Value	RST/PWR	Description
				This field contains the row# with the error
20:17	RO	0000b	Core	Reserved (RSVD):
16	WO	0b	Core	Valid Error 1 (VLDERR1): Valid Error: The error located in field 15:5 is valid and corresponding logical 16KB group should bypass this row.
15:5	WO	000h	Core	Row Number for Error0 (RNUMERR0): Row Number for Error0: The physical row number where the parity error has been detected. The number of rows vary between 4K vs 8K/16K subbanks which requires 10bits vs 11bits respectively. This field contains the row# with the error
4:1	RO	0000b	Core	Reserved (RSVD):
0	WO	0b	Core	Valid Error 0 (VLDERR0): Valid Error: The error located in field 15:5 is valid and corresponding logical 16KB group should bypass this row.

L3B1REG01 - L3 bank1 reg1 log error slice 0

B/D/F/Type: 0/0/0/SARBunit_Config

Address Offset: B094-B097h

Default Value: 00000000h

Access: WO; RO;

Size: 32 bits

The ERROR LOG registers of L3 will maintain the bad row information for each of the 16KB subbank groups. The LOG will be programmed by driver before any workloads are submitted.

The contents of the LOG register will be context Save&Restored by h/w around rc6 events.

Bit	Access	Default Value	RST/PWR	Description
-----	--------	---------------	---------	-------------



Bit	Access	Default Value	RST/PWR	Description
31:21	WO	000h	Core	<p>Row Number for Error1 (RNUMERR1):</p> <p>Row Number for Error1:</p> <p>The physical row number where the parity error has been detected. The number of rows vary between 4K vs 8K/16K subbanks which requires 10bits vs 11bits respectively.</p> <p>This field contains the row# with the error</p>
20:17	RO	0000b	Core	<p>Reserved (RSVD):</p>
16	WO	0b	Core	<p>Valid Error 1 (VLDERR1):</p> <p>Valid Error:</p> <p>The error located in field 15:5 is valid and corresponding logical 16KB group should bypass this row.</p>
15:5	WO	000h	Core	<p>Row Number for Error0 (RNUMERR0):</p> <p>Row Number for Error0:</p> <p>The physical row number where the parity error has been detected. The number of rows vary between 4K vs 8K/16K subbanks which requires 10bits vs 11bits respectively.</p> <p>This field contains the row# with the error</p>
4:1	RO	0000b	Core	<p>Reserved (RSVD):</p>
0	WO	0b	Core	<p>Valid Error 0 (VLDERR0):</p> <p>Valid Error:</p> <p>The error located in field 15:5 is valid and corresponding logical 16KB group should bypass this row.</p>

L3B1REG02 - L3 bank1 reg2 log error slice 0

B/D/F/Type: 0/0/0/SARBunit_Config
Address Offset: B098-B09Bh
Default Value: 00000000h
Access: WO; RO;
Size: 32 bits



The ERROR LOG registers of L3 will maintain the bad row information for each of the 16KB subbank groups. The LOG will be programmed by driver before any workloads are submitted.

The contents of the LOG register will be context Save&Restored by h/w around rc6 events.

Bit	Access	Default Value	RST/PWR	Description
31:21	WO	000h	Core	<p>Row Number for Error1 (RNUMERR1):</p> <p>Row Number for Error1:</p> <p>The physical row number where the parity error has been detected. The number of rows vary between 4K vs 8K/16K subbanks which requires 10bits vs 11bits respectively.</p> <p>This field contains the row# with the error</p>
20:17	RO	0000b	Core	<p>Reserved (RSVD):</p>
16	WO	0b	Core	<p>Valid Error 1 (VLDERR1):</p> <p>Valid Error:</p> <p>The error located in field 15:5 is valid and corresponding logical 16KB group should bypass this row.</p>
15:5	WO	000h	Core	<p>Row Number for Error0 (RNUMERR0):</p> <p>Row Number for Error0:</p> <p>The physical row number where the parity error has been detected. The number of rows vary between 4K vs 8K/16K subbanks which requires 10bits vs 11bits respectively.</p> <p>This field contains the row# with the error</p>
4:1	RO	0000b	Core	<p>Reserved (RSVD):</p>
0	WO	0b	Core	<p>Valid Error 0 (VLDERR0):</p> <p>Valid Error:</p> <p>The error located in field 15:5 is valid and corresponding logical 16KB group should bypass this row.</p>



L3B1REG03 - L3 bank1 reg3 log error slice 0

B/D/F/Type: 0/0/0/SARBunit_Confi
 g
Address Offset: B09C-B09Fh
Default Value: 00000000h
Access: WO; RO;
Size: 32 bits

The ERROR LOG registers of L3 will maintain the bad row information for each of the 16KB subbank groups. The LOG will be programmed by driver before any workloads are submitted.

The contents of the LOG register will be context Save&Restored by h/w around rc6 events.

Bit	Access	Default Value	RST/PWR	Description
31:21	WO	000h	Core	Row Number for Error1 (RNUMERR1): Row Number for Error1: The physical row number where the parity error has been detected. The number of rows vary between 4K vs 8K/16K subbanks which requires 10bits vs 11bits respectively. This field contains the row# with the error
20:17	RO	0000b	Core	Reserved (RSVD):
16	WO	0b	Core	Valid Error 1 (VLDERR1): Valid Error: The error located in field 15:5 is valid and corresponding logical 16KB group should bypass this row.
15:5	WO	000h	Core	Row Number for Error0 (RNUMERR0): Row Number for Error0: The physical row number where the parity error has been detected. The number of rows vary between 4K vs 8K/16K subbanks which requires 10bits vs 11bits respectively. This field contains the row# with the error
4:1	RO	0000b	Core	Reserved (RSVD):
0	WO	0b	Core	Valid Error 0 (VLDERR0): Valid Error:



Bit	Access	Default Value	RST/PWR	Description
				The error located in field 15:5 is valid and corresponding logical 16KB group should bypass this row.



L3B1REG04 - L3 bank1 reg4 log error slice 0

B/D/F/Type: 0/0/0/SARBunit_Confi
g
Address Offset: B0A0-B0A3h
Default Value: 00000000h
Access: WO; RO;
Size: 32 bits

The ERROR LOG registers of L3 will maintain the bad row information for each of the 16KB subbank groups. The LOG will be programmed by driver before any workloads are submitted.

The contents of the LOG register will be context Save&Restored by h/w around rc6 events.

Bit	Access	Default Value	RST/PWR	Description
31:21	WO	000h	Core	Row Number for Error1 (RNUMERR1): Row Number for Error1: The physical row number where the parity error has been detected. The number of rows vary between 4K vs 8K/16K subbanks which requires 10bits vs 11bits respectively. This field contains the row# with the error
20:17	RO	0000b	Core	Reserved (RSVD):
16	WO	0b	Core	Valid Error 1 (VLDERR1): Valid Error: The error located in field 15:5 is valid and corresponding logical 16KB group should bypass this row.
15:5	WO	000h	Core	Row Number for Error0 (RNUMERR0): Row Number for Error0: The physical row number where the parity error has been detected. The number of rows vary between 4K vs 8K/16K subbanks which requires 10bits vs 11bits respectively. This field contains the row# with the error
4:1	RO	0000b	Core	Reserved (RSVD):
0	WO	0b	Core	Valid Error 0 (VLDERR0): Valid Error:



Bit	Access	Default Value	RST/PWR	Description
				The error located in field 15:5 is valid and corresponding logical 16KB group should bypass this row.



L3B1REG05 - L3 bank1 reg5 log error slice 0

B/D/F/Type: 0/0/0/SARBunit_Confi
g
Address Offset: B0A4-B0A7h
Default Value: 00000000h
Access: WO; RO;
Size: 32 bits

The ERROR LOG registers of L3 will maintain the bad row information for each of the 16KB subbank groups. The LOG will be programmed by driver before any workloads are submitted.

The contents of the LOG register will be context Save&Restored by h/w around rc6 events.

Bit	Access	Default Value	RST/PWR	Description
31:21	WO	000h	Core	Row Number for Error1 (RNUMERR1): Row Number for Error1: The physical row number where the parity error has been detected. The number of rows vary between 4K vs 8K/16K subbanks which requires 10bits vs 11bits respectively. This field contains the row# with the error
20:17	RO	0000b	Core	Reserved (RSVD):
16	WO	0b	Core	Valid Error 1 (VLDERR1): Valid Error: The error located in field 15:5 is valid and corresponding logical 16KB group should bypass this row.
15:5	WO	000h	Core	Row Number for Error0 (RNUMERR0): Row Number for Error0: The physical row number where the parity error has been detected. The number of rows vary between 4K vs 8K/16K subbanks which requires 10bits vs 11bits respectively. This field contains the row# with the error
4:1	RO	0000b	Core	Reserved (RSVD):
0	WO	0b	Core	Valid Error 0 (VLDERR0): Valid Error:



Bit	Access	Default Value	RST/PWR	Description
				The error located in field 15:5 is valid and corresponding logical 16KB group should bypass this row.



L3B1REG06 - L3 bank1 reg6 log error slice 0

B/D/F/Type: 0/0/0/SARBunit_Confi
g
Address Offset: B0A8-B0ABh
Default Value: 00000000h
Access: WO; RO;
Size: 32 bits

The ERROR LOG registers of L3 will maintain the bad row information for each of the 16KB subbank groups. The LOG will be programmed by driver before any workloads are submitted.

The contents of the LOG register will be context Save&Restored by h/w around rc6 events.

Bit	Access	Default Value	RST/PWR	Description
31:21	WO	000h	Core	Row Number for Error1 (RNUMERR1): Row Number for Error1: The physical row number where the parity error has been detected. The number of rows vary between 4K vs 8K/16K subbanks which requires 10bits vs 11bits respectively. This field contains the row# with the error
20:17	RO	0000b	Core	Reserved (RSVD):
16	WO	0b	Core	Valid Error 1 (VLDERR1): Valid Error: The error located in field 15:5 is valid and corresponding logical 16KB group should bypass this row.
15:5	WO	000h	Core	Row Number for Error0 (RNUMERR0): Row Number for Error0: The physical row number where the parity error has been detected. The number of rows vary between 4K vs 8K/16K subbanks which requires 10bits vs 11bits respectively. This field contains the row# with the error
4:1	RO	0000b	Core	Reserved (RSVD):
0	WO	0b	Core	Valid Error 0 (VLDERR0): Valid Error:



Bit	Access	Default Value	RST/PWR	Description
				The error located in field 15:5 is valid and corresponding logical 16KB group should bypass this row.



L3B1REG07 - L3 bank1 reg7 log error slice 0

B/D/F/Type: 0/0/0/SARBunit_Confi
 g
Address Offset: B0AC-B0AFh
Default Value: 00000000h
Access: WO; RO;
Size: 32 bits

The ERROR LOG registers of L3 will maintain the bad row information for each of the 16KB subbank groups. The LOG will be programmed by driver before any workloads are submitted.

The contents of the LOG register will be context Save&Restored by h/w around rc6 events.

Bit	Access	Default Value	RST/PWR	Description
31:21	WO	000h	Core	Row Number for Error1 (RNUMERR1): Row Number for Error1: The physical row number where the parity error has been detected. The number of rows vary between 4K vs 8K/16K subbanks which requires 10bits vs 11bits respectively. This field contains the row# with the error
20:17	RO	0000b	Core	Reserved (RSVD):
16	WO	0b	Core	Valid Error 1 (VLDERR1): Valid Error: The error located in field 15:5 is valid and corresponding logical 16KB group should bypass this row.
15:5	WO	000h	Core	Row Number for Error0 (RNUMERR0): Row Number for Error0: The physical row number where the parity error has been detected. The number of rows vary between 4K vs 8K/16K subbanks which requires 10bits vs 11bits respectively. This field contains the row# with the error
4:1	RO	0000b	Core	Reserved (RSVD):
0	WO	0b	Core	Valid Error 0 (VLDERR0): Valid Error:



Bit	Access	Default Value	RST/PWR	Description
				The error located in field 15:5 is valid and corresponding logical 16KB group should bypass this row.



L3B2REG00 - L3 bank2 reg0 log error slice 0

B/D/F/Type: 0/0/0/SARBunit_Confi
g
Address Offset: B0B0-B0B3h
Default Value: 00000000h
Access: WO; RO;
Size: 32 bits

The ERROR LOG registers of L3 will maintain the bad row information for each of the 16KB subbank groups. The LOG will be programmed by driver before any workloads are submitted.

The contents of the LOG register will be context Save&Restored by h/w around rc6 events.

Bit	Access	Default Value	RST/PWR	Description
31:21	WO	000h	Core	Row Number for Error1 (RNUMERR1): Row Number for Error1: The physical row number where the parity error has been detected. The number of rows vary between 4K vs 8K/16K subbanks which requires 10bits vs 11bits respectively. This field contains the row# with the error
20:17	RO	0000b	Core	Reserved (RSVD):
16	WO	0b	Core	Valid Error 1 (VLDERR1): Valid Error: The error located in field 15:5 is valid and corresponding logical 16KB group should bypass this row.
15:5	WO	000h	Core	Row Number for Error0 (RNUMERR0): Row Number for Error0: The physical row number where the parity error has been detected. The number of rows vary between 4K vs 8K/16K subbanks which requires 10bits vs 11bits respectively. This field contains the row# with the error
4:1	RO	0000b	Core	Reserved (RSVD):
0	WO	0b	Core	Valid Error 0 (VLDERR0): Valid Error:



Bit	Access	Default Value	RST/PWR	Description
				The error located in field 15:5 is valid and corresponding logical 16KB group should bypass this row.



L3B2REG01 - L3 bank2 reg1 log error slice 0

B/D/F/Type: 0/0/0/SARBunit_Confi
 g
Address Offset: B0B4-B0B7h
Default Value: 00000000h
Access: WO; RO;
Size: 32 bits

The ERROR LOG registers of L3 will maintain the bad row information for each of the 16KB subbank groups. The LOG will be programmed by driver before any workloads are submitted.

The contents of the LOG register will be context Save&Restored by h/w around rc6 events.

Bit	Access	Default Value	RST/PWR	Description
31:21	WO	000h	Core	Row Number for Error1 (RNUMERR1): Row Number for Error1: The physical row number where the parity error has been detected. The number of rows vary between 4K vs 8K/16K subbanks which requires 10bits vs 11bits respectively. This field contains the row# with the error
20:17	RO	0000b	Core	Reserved (RSVD):
16	WO	0b	Core	Valid Error 1 (VLDERR1): Valid Error: The error located in field 15:5 is valid and corresponding logical 16KB group should bypass this row.
15:5	WO	000h	Core	Row Number for Error0 (RNUMERR0): Row Number for Error0: The physical row number where the parity error has been detected. The number of rows vary between 4K vs 8K/16K subbanks which requires 10bits vs 11bits respectively. This field contains the row# with the error
4:1	RO	0000b	Core	Reserved (RSVD):
0	WO	0b	Core	Valid Error 0 (VLDERR0): Valid Error:



Bit	Access	Default Value	RST/PWR	Description
				The error located in field 15:5 is valid and corresponding logical 16KB group should bypass this row.



L3B2REG02 - L3 bank2 reg2 log error slice 0

B/D/F/Type: 0/0/0/SARBunit_Confi
 g
Address Offset: B0B8-B0BBh
Default Value: 00000000h
Access: WO; RO;
Size: 32 bits

The ERROR LOG registers of L3 will maintain the bad row information for each of the 16KB subbank groups. The LOG will be programmed by driver before any workloads are submitted.

The contents of the LOG register will be context Save&Restored by h/w around rc6 events.

Bit	Access	Default Value	RST/PWR	Description
31:21	WO	000h	Core	Row Number for Error1 (RNUMERR1): Row Number for Error1: The physical row number where the parity error has been detected. The number of rows vary between 4K vs 8K/16K subbanks which requires 10bits vs 11bits respectively. This field contains the row# with the error
20:17	RO	0000b	Core	Reserved (RSVD):
16	WO	0b	Core	Valid Error 1 (VLDERR1): Valid Error: The error located in field 15:5 is valid and corresponding logical 16KB group should bypass this row.
15:5	WO	000h	Core	Row Number for Error0 (RNUMERR0): Row Number for Error0: The physical row number where the parity error has been detected. The number of rows vary between 4K vs 8K/16K subbanks which requires 10bits vs 11bits respectively. This field contains the row# with the error
4:1	RO	0000b	Core	Reserved (RSVD):
0	WO	0b	Core	Valid Error 0 (VLDERR0):



Bit	Access	Default Value	RST/PWR	Description
				Valid Error: The error located in field 15:5 is valid and corresponding logical 16KB group should bypass this row.



L3B2REG03 - L3 bank2 reg3 log error slice 0

B/D/F/Type: 0/0/0/SARBunit_Confi
g
Address Offset: B0BC-B0BFh
Default Value: 00000000h
Access: WO; RO;
Size: 32 bits

The ERROR LOG registers of L3 will maintain the bad row information for each of the 16KB subbank groups. The LOG will be programmed by driver before any workloads are submitted.

The contents of the LOG register will be context Save&Restored by h/w around rc6 events.

Bit	Access	Default Value	RST/PWR	Description
31:21	WO	000h	Core	Row Number for Error1 (RNUMERR1): Row Number for Error1: The physical row number where the parity error has been detected. The number of rows vary between 4K vs 8K/16K subbanks which requires 10bits vs 11bits respectively. This field contains the row# with the error
20:17	RO	0000b	Core	Reserved (RSVD):
16	WO	0b	Core	Valid Error 1 (VLDERR1): Valid Error: The error located in field 15:5 is valid and corresponding logical 16KB group should bypass this row.
15:5	WO	000h	Core	Row Number for Error0 (RNUMERR0): Row Number for Error0: The physical row number where the parity error has been detected. The number of rows vary between 4K vs 8K/16K subbanks which requires 10bits vs 11bits respectively. This field contains the row# with the error
4:1	RO	0000b	Core	Reserved (RSVD):
0	WO	0b	Core	Valid Error 0 (VLDERR0): Valid Error:



Bit	Access	Default Value	RST/PWR	Description
				The error located in field 15:5 is valid and corresponding logical 16KB group should bypass this row.



L3B2REG04 - L3 bank2 reg4 log error slice 0

B/D/F/Type: 0/0/0/SARBunit_Confi
g
Address Offset: B0C0-B0C3h
Default Value: 00000000h
Access: WO; RO;
Size: 32 bits

The ERROR LOG registers of L3 will maintain the bad row information for each of the 16KB subbank groups. The LOG will be programmed by driver before any workloads are submitted.

The contents of the LOG register will be context Save&Restored by h/w around rc6 events.

Bit	Access	Default Value	RST/PWR	Description
31:21	WO	000h	Core	Row Number for Error1 (RNUMERR1): Row Number for Error1: The physical row number where the parity error has been detected. The number of rows vary between 4K vs 8K/16K subbanks which requires 10bits vs 11bits respectively. This field contains the row# with the error
20:17	RO	0000b	Core	Reserved (RSVD):
16	WO	0b	Core	Valid Error 1 (VLDERR1): Valid Error: The error located in field 15:5 is valid and corresponding logical 16KB group should bypass this row.
15:5	WO	000h	Core	Row Number for Error0 (RNUMERR0): Row Number for Error0: The physical row number where the parity error has been detected. The number of rows vary between 4K vs 8K/16K subbanks which requires 10bits vs 11bits respectively. This field contains the row# with the error
4:1	RO	0000b	Core	Reserved (RSVD):
0	WO	0b	Core	Valid Error 0 (VLDERR0): Valid Error:



Bit	Access	Default Value	RST/PWR	Description
				The error located in field 15:5 is valid and corresponding logical 16KB group should bypass this row.



L3B2REG05 - L3 bank2 reg5 log error slice 0

B/D/F/Type: 0/0/0/SARBunit_Confi
g
Address Offset: B0C4-B0C7h
Default Value: 00000000h
Access: WO; RO;
Size: 32 bits

The ERROR LOG registers of L3 will maintain the bad row information for each of the 16KB subbank groups. The LOG will be programmed by driver before any workloads are submitted.

The contents of the LOG register will be context Save&Restored by h/w around rc6 events.

Bit	Access	Default Value	RST/PWR	Description
31:21	WO	000h	Core	Row Number for Error1 (RNUMERR1): Row Number for Error1: The physical row number where the parity error has been detected. The number of rows vary between 4K vs 8K/16K subbanks which requires 10bits vs 11bits respectively. This field contains the row# with the error
20:17	RO	0000b	Core	Reserved (RSVD):
16	WO	0b	Core	Valid Error 1 (VLDERR1): Valid Error: The error located in field 15:5 is valid and corresponding logical 16KB group should bypass this row.
15:5	WO	000h	Core	Row Number for Error0 (RNUMERR0): Row Number for Error0: The physical row number where the parity error has been detected. The number of rows vary between 4K vs 8K/16K subbanks which requires 10bits vs 11bits respectively. This field contains the row# with the error
4:1	RO	0000b	Core	Reserved (RSVD):
0	WO	0b	Core	Valid Error 0 (VLDERR0): Valid Error:



Bit	Access	Default Value	RST/PWR	Description
				The error located in field 15:5 is valid and corresponding logical 16KB group should bypass this row.



L3B2REG06 - L3 bank2 reg6 log error slice 0

B/D/F/Type: 0/0/0/SARBunit_Confi
g
Address Offset: B0C8-B0CBh
Default Value: 00000000h
Access: WO; RO;
Size: 32 bits

The ERROR LOG registers of L3 will maintain the bad row information for each of the 16KB subbank groups. The LOG will be programmed by driver before any workloads are submitted.

The contents of the LOG register will be context Save&Restored by h/w around rc6 events.

Bit	Access	Default Value	RST/PWR	Description
31:21	WO	000h	Core	Row Number for Error1 (RNUMERR1): Row Number for Error1: The physical row number where the parity error has been detected. The number of rows vary between 4K vs 8K/16K subbanks which requires 10bits vs 11bits respectively. This field contains the row# with the error
20:17	RO	0000b	Core	Reserved (RSVD):
16	WO	0b	Core	Valid Error 1 (VLDERR1): Valid Error: The error located in field 15:5 is valid and corresponding logical 16KB group should bypass this row.
15:5	WO	000h	Core	Row Number for Error0 (RNUMERR0): Row Number for Error0: The physical row number where the parity error has been detected. The number of rows vary between 4K vs 8K/16K subbanks which requires 10bits vs 11bits respectively. This fiel
4:1	RO	0000b	Core	Reserved (RSVD):
0	WO	0b	Core	Valid Error 0 (VLDERR0): Valid Error:



Bit	Access	Default Value	RST/PWR	Description
				The error located in field 15:5 is valid and corresponding logical 16KB group should bypass this row.



L3B2REG07 - L3 bank2 reg7 log error slice 0

B/D/F/Type: 0/0/0/SARBunit_Confi
g
Address Offset: B0CC-B0CFh
Default Value: 00000000h
Access: WO; RO;
Size: 32 bits

The ERROR LOG registers of L3 will maintain the bad row information for each of the 16KB subbank groups. The LOG will be programmed by driver before any workloads are submitted.

The contents of the LOG register will be context Save&Restored by h/w around rc6 events.

Bit	Access	Default Value	RST/PWR	Description
31:21	WO	000h	Core	Row Number for Error1 (RNUMERR1): Row Number for Error1: The physical row number where the parity error has been detected. The number of rows vary between 4K vs 8K/16K subbanks which requires 10bits vs 11bits respectively. This field contains the row# with the error
20:17	RO	0000b	Core	Reserved (RSVD):
16	WO	0b	Core	Valid Error 1 (VLDERR1): Valid Error: The error located in field 15:5 is valid and corresponding logical 16KB group should bypass this row.
15:5	WO	000h	Core	Row Number for Error0 (RNUMERR0): Row Number for Error0: The physical row number where the parity error has been detected. The number of rows vary between 4K vs 8K/16K subbanks which requires 10bits vs 11bits respectively. This field contains the row# with the error
4:1	RO	0000b	Core	Reserved (RSVD):
0	WO	0b	Core	Valid Error 0 (VLDERR0): Valid Error:



Bit	Access	Default Value	RST/PWR	Description
				The error located in field 15:5 is valid and corresponding logical 16KB group should bypass this row.



L3B3REG00 - L3 bank3 reg0 log error slice 0

B/D/F/Type: 0/0/0/SARBunit_Confi
 g
Address Offset: B0D0-B0D3h
Default Value: 00000000h
Access: WO; RO;
Size: 32 bits

The ERROR LOG registers of L3 will maintain the bad row information for each of the 16KB subbank groups. The LOG will be programmed by driver before any workloads are submitted.

The contents of the LOG register will be context Save&Restored by h/w around rc6 events.

Bit	Access	Default Value	RST/PWR	Description
31:21	WO	000h	Core	Row Number for Error1 (RNUMERR1): Row Number for Error1: The physical row number where the parity error has been detected. The number of rows vary between 4K vs 8K/16K subbanks which requires 10bits vs 11bits respectively. This field contains the row# with the error
20:17	RO	0000b	Core	Reserved (RSVD):
16	WO	0b	Core	Valid Error 1 (VLDERR1): Valid Error: The error located in field 15:5 is valid and corresponding logical 16KB group should bypass this row.
15:5	WO	000h	Core	Row Number for Error0 (RNUMERR0): Row Number for Error0: The physical row number where the parity error has been detected. The number of rows vary between 4K vs 8K/16K subbanks which requires 10bits vs 11bits respectively. This field contains the row# with the error
4:1	RO	0000b	Core	Reserved (RSVD):
0	WO	0b	Core	Valid Error 0 (VLDERR0): Valid Error:



Bit	Access	Default Value	RST/PWR	Description
				The error located in field 15:5 is valid and corresponding logical 16KB group should bypass this row.



L3B3REG01 - L3 bank3 reg1 log error slice 0

B/D/F/Type: 0/0/0/SARBunit_Confi
 g
Address Offset: B0D4-B0D7h
Default Value: 00000000h
Access: WO; RO;
Size: 32 bits

The ERROR LOG registers of L3 will maintain the bad row information for each of the 16KB subbank groups. The LOG will be programmed by driver before any workloads are submitted.

The contents of the LOG register will be context Save&Restored by h/w around rc6 events.

Bit	Access	Default Value	RST/PWR	Description
31:21	WO	000h	Core	Row Number for Error1 (RNUMERR1): Row Number for Error1: The physical row number where the parity error has been detected. The number of rows vary between 4K vs 8K/16K subbanks which requires 10bits vs 11bits respectively. This field contains the row# with the error
20:17	RO	0000b	Core	Reserved (RSVD):
16	WO	0b	Core	Valid Error 1 (VLDERR1): Valid Error: The error located in field 15:5 is valid and corresponding logical 16KB group should bypass this row.
15:5	WO	000h	Core	Row Number for Error0 (RNUMERR0): Row Number for Error0: The physical row number where the parity error has been detected. The number of rows vary between 4K vs 8K/16K subbanks which requires 10bits vs 11bits respectively. This field contains the row# with the error
4:1	RO	0000b	Core	Reserved (RSVD):
0	WO	0b	Core	Valid Error 0 (VLDERR0): Valid Error:



Bit	Access	Default Value	RST/PWR	Description
				The error located in field 15:5 is valid and corresponding logical 16KB group should bypass this row.

L3B3REG02 - L3 bank3 reg2 log error slice 0

B/D/F/Type: 0/0/0/SARBunit_Confi
g

Address Offset: B0D8-B0DBh

Default Value: 00000000h

Access: WO; RO;

Size: 32 bits

The ERROR LOG registers of L3 will maintain the bad row information for each of the 16KB subbank groups. The LOG will be programmed by driver before any workloads are submitted.

The contents of the LOG register will be context Save&Restored by h/w around rc6 events.

Bit	Access	Default Value	RST/PWR	Description
31:21	WO	000h	Core	Row Number for Error1 (RNUMERR1): Row Number for Error1: The physical row number where the parity error has been detected. The number of rows vary between 4K vs 8K/16K subbanks which requires 10bits vs 11bits respectively. This field contains the row# with the error
20:17	RO	0000b	Core	Reserved (RSVD):
16	WO	0b	Core	Valid Error 1 (VLDERR1): Valid Error: The error located in field 15:5 is valid and corresponding logical 16KB group should bypass this row.
15:5	WO	000h	Core	Row Number for Error0 (RNUMERR0): Row Number for Error0: The physical row number where the parity error has been detected. The number of rows vary between 4K vs 8K/16K subbanks which requires 10bits vs 11bits respectively. This field contains the row# with the error



Bit	Access	Default Value	RST/PWR	Description
4:1	RO	0000b	Core	Reserved (RSVD):
0	WO	0b	Core	Valid Error 0 (VLDERR0): Valid Error: The error located in field 15:5 is valid and corresponding logical 16KB group should bypass this row.

L3B3REG03 - L3 bank3 reg3 log error slice 0

B/D/F/Type: 0/0/0/SARBunit_Confi
g

Address Offset: B0DC-B0DFh

Default Value: 00000000h

Access: WO; RO;

Size: 32 bits

The ERROR LOG registers of L3 will maintain the bad row information for each of the 16KB subbank groups. The LOG will be programmed by driver before any workloads are submitted.

The contents of the LOG register will be context Save&Restored by h/w around rc6 events.

Bit	Access	Default Value	RST/PWR	Description
31:21	WO	000h	Core	Row Number for Error1 (RNUMERR1): Row Number for Error1: The physical row number where the parity error has been detected. The number of rows vary between 4K vs 8K/16K subbanks which requires 10bits vs 11bits respectively. This field contains the row# with the error
20:17	RO	0000b	Core	Reserved (RSVD):
16	WO	0b	Core	Valid Error 1 (VLDERR1): Valid Error: The error located in field 15:5 is valid and corresponding logical 16KB group should bypass this row.
15:5	WO	000h	Core	Row Number for Error0 (RNUMERR0):



Bit	Access	Default Value	RST/PWR	Description
				<p>Row Number for Error0:</p> <p>The physical row number where the parity error has been detected. The number of rows vary between 4K vs 8K/16K subbanks which requires 10bits vs 11bits respectively.</p> <p>This field contains the row# with the error</p>
4:1	RO	0000b	Core	Reserved (RSVD):
0	WO	0b	Core	<p>Valid Error 0 (VLDERR0):</p> <p>Valid Error:</p> <p>The error located in field 15:5 is valid and corresponding logical 16KB group should bypass this row.</p>

L3B3REG04 - L3 bank3 reg4 log error slice 0

B/D/F/Type: 0/0/0/SARBunit_Confi
g

Address Offset: B0E0-B0E3h

Default Value: 00000000h

Access: WO; RO;

Size: 32 bits

The ERROR LOG registers of L3 will maintain the bad row information for each of the 16KB subbank groups. The LOG will be programmed by driver before any workloads are submitted.

The contents of the LOG register will be context Save&Restored by h/w around rc6 events.

Bit	Access	Default Value	RST/PWR	Description
31:21	WO	000h	Core	<p>Row Number for Error1 (RNUMERR1):</p> <p>Row Number for Error1:</p> <p>The physical row number where the parity error has been detected. The number of rows vary between 4K vs 8K/16K subbanks which requires 10bits vs 11bits respectively.</p> <p>This field contains the row# with the error</p>
20:17	RO	0000b	Core	Reserved (RSVD):
16	WO	0b	Core	Valid Error 1 (VLDERR1):



Bit	Access	Default Value	RST/PWR	Description
				Valid Error: The error located in field 15:5 is valid and corresponding logical 16KB group should bypass this row.
15:5	WO	000h	Core	Row Number for Error0 (RNUMERR0): Row Number for Error0: The physical row number where the parity error has been detected. The number of rows vary between 4K vs 8K/16K subbanks which requires 10bits vs 11bits respectively. This field contains the row# with the error
4:1	RO	0000b	Core	Reserved (RSVD):
0	WO	0b	Core	Valid Error 0 (VLDERR0): Valid Error: The error located in field 15:5 is valid and corresponding logical 16KB group should bypass this row.

L3B3REG05 - L3 bank3 reg5 log error slice 0

B/D/F/Type: 0/0/0/SARBunit_Config

Address Offset: B0E4-B0E7h

Default Value: 00000000h

Access: WO; RO;

Size: 32 bits

The ERROR LOG registers of L3 will maintain the bad row information for each of the 16KB subbank groups. The LOG will be programmed by driver before any workloads are submitted.

The contents of the LOG register will be context Save&Restored by h/w around rc6 events.

Bit	Access	Default Value	RST/PWR	Description
31:21	WO	000h	Core	Row Number for Error1 (RNUMERR1): Row Number for Error1: The physical row number where the parity error has been detected. The number of rows vary between 4K vs 8K/16K subbanks which requires 10bits vs 11bits respectively.



Bit	Access	Default Value	RST/PWR	Description
				This field contains the row# with the error
20:17	RO	0000b	Core	Reserved (RSVD):
16	WO	0b	Core	Valid Error 1 (VLDERR1): Valid Error: The error located in field 15:5 is valid and corresponding logical 16KB group should bypass this row.
15:5	WO	000h	Core	Row Number for Error0 (RNUMERR0): Row Number for Error0: The physical row number where the parity error has been detected. The number of rows vary between 4K vs 8K/16K subbanks which requires 10bits vs 11bits respectively. This field contains the row# with the error
4:1	RO	0000b	Core	Reserved (RSVD):
0	WO	0b	Core	Valid Error 0 (VLDERR0): Valid Error: The error located in field 15:5 is valid and corresponding logical 16KB group should bypass this row.



L3B3REG06 - L3 bank3 reg6 log error slice 0

B/D/F/Type: 0/0/0/SARBunit_Confi
g
Address Offset: B0E8-B0EBh
Default Value: 00000000h
Access: WO; RO;
Size: 32 bits

The ERROR LOG registers of L3 will maintain the bad row information for each of the 16KB subbank groups. The LOG will be programmed by driver before any workloads are submitted.

The contents of the LOG register will be context Save&Restored by h/w around rc6 events.

Bit	Access	Default Value	RST/PWR	Description
31:21	WO	000h	Core	Row Number for Error1 (RNUMERR1): Row Number for Error1: The physical row number where the parity error has been detected. The number of rows vary between 4K vs 8K/16K subbanks which requires 10bits vs 11bits respectively. This field contains the row# with the error
20:17	RO	0000b	Core	Reserved (RSVD):
16	WO	0b	Core	Valid Error 1 (VLDERR1): Valid Error: The error located in field 15:5 is valid and corresponding logical 16KB group should bypass this row.
15:5	WO	000h	Core	Row Number for Error0 (RNUMERR0): Row Number for Error0: The physical row number where the parity error has been detected. The number of rows vary between 4K vs 8K/16K subbanks which requires 10bits vs 11bits respectively. This field contains the row# with the error
4:1	RO	0000b	Core	Reserved (RSVD):
0	WO	0b	Core	Valid Error 0 (VLDERR0): Valid Error:



Bit	Access	Default Value	RST/PWR	Description
				The error located in field 15:5 is valid and corresponding logical 16KB group should bypass this row.

L3B3REG07 - L3 bank3 reg7 log error slice 0

B/D/F/Type: 0/0/0/SARBunit_Confi
g

Address Offset: B0EC-B0EFh

Default Value: 00000000h

Access: WO; RO;

Size: 32 bits

The ERROR LOG registers of L3 will maintain the bad row information for each of the 16KB subbank groups. The LOG will be programmed by driver before any workloads are submitted.

The contents of the LOG register will be context Save&Restored by h/w around rc6 events.

Bit	Access	Default Value	RST/PWR	Description
31:21	WO	000h	Core	Row Number for Error1 (RNUMERR1): Row Number for Error1: The physical row number where the parity error has been detected. The number of rows vary between 4K vs 8K/16K subbanks which requires 10bits vs 11bits respectively. This field contains the row# with the error
20:17	RO	0000b	Core	Reserved (RSVD):
16	WO	0b	Core	Valid Error 1 (VLDERR1): Valid Error: The error located in field 15:5 is valid and corresponding logical 16KB group should bypass this row.
15:5	WO	000h	Core	Row Number for Error0 (RNUMERR0): Row Number for Error0: The physical row number where the parity error has been detected. The number of rows vary between 4K vs 8K/16K subbanks which requires 10bits vs 11bits respectively. This field contains the row# with the error



Bit	Access	Default Value	RST/PWR	Description
4:1	RO	0000b	Core	Reserved (RSVD):
0	WO	0b	Core	Valid Error 0 (VLDERR0): Valid Error: The error located in field 15:5 is valid and corresponding logical 16KB group should bypass this row.

LPFCREG0 - First Buffer Size and Start

B/D/F/Type: 0/0/0/SARBunit_Confi
g

Address Offset: B0F0-B0F3h

Default Value: 00000000h

Access: WO; RO;

Size: 32 bits

Bit	Access	Default Value	RST/PWR	Description
31:16	RW	0000h	Core	First Virtual Buffer Base (FVBB): First Virtual Buffer Base: Programmed by driver to allocate a space for performance data storage. The buffer size should be aligned to the size of the memory allocated so it naturally aligns to the base (i.e. for 128KB bit[16]=0, 256KB bit[17:16]=0, 512KB bit[18:16]=0) Signal - sarbcf_lpfc_virtual_base0[31:16]
15:12	RW	0000b	Core	First Buffer Size (FBS): First Buffer Size: Determines the allowed buffer size for performance data storage 0000: 64KB 0001: 128KB 0010: 256KB 0011: 512KB . . 1111: 2GB



Bit	Access	Default Value	RST/PWR	Description
				Signal - sarbcf_lpfc_buffer_size0[3:0]
11:3	RO	000h	Core	Reserved (RSVD):
2	RW	0b	Core	<p>Frame Cnt and Draw Call Enable (FCDCE):</p> <p>Frame Cnt and Draw Call Enable - If this mode is enabled then one of the counters will be replaced by Frame Cnt and Draw call numbers to format the data packet to memory</p> <p>Signal - sarbcf_csr_lpfc_framecnt_en</p> <p>this bit is used by both slices</p>
1	RW	0b	Core	<p>Enable Dual-buffer mode (EDBM):</p> <p>Enable Dual-buffer mode: It enables the capability of h/w generating interrupts to GFX driver to enable double buffering where memory content can be dumped into hard-drive to enable usage of hard drive for performance content.</p> <p>Signal - sarbcf_lpfc_mode_sel</p> <p>this bit is used by both slices</p>
0	RW	0b	Core	<p>Master Counter Enable (MCE):</p> <p>Master Counter Enable: This is the global enable for performance tracking once set, it will kick off all performance tracking mechanism.</p> <p>Signal - sarbcf_lpfc_master_cnt_en</p> <p>this bit is used by both slices</p> <p><i>Workaround: For LPFC to dump the contents of the last buffer (if buffer is not filled up), it needs to be disabled.</i></p>

LPFCREG2 - Second Buffer Size

B/D/F/Type: 0/0/0/SARBunit_Config
Address Offset: B0F4-B0F7h
Default Value: 00000000h
Access: WO; RO;
Size: 32 bits



Bit	Access	Default Value	RST/PWR	Description
31:16	RW	0000h	Core	Second Virtual Buffer Base (SVBB0): Second Virtual Buffer Base: Programmed by driver to allocate a space for performance data storage. The buffer size should be aligned to the size of the memory allocated so it naturally aligns to the base (i.e. for 128KB bit[16]=0, 256KB bit[17:16]=0, 512KB bit[18:16]=0) Signal - sarbcf_lpfv_virtual_base1[31:16]
15:12	RW	0000b	Core	Second Buffer Size 0 (SBS0): Second Buffer Size: Determines the allowed buffer size for performance data storage 0000: 64KB 0001: 128KB 0010: 256KB 0011: 512KB . . 1111: 2GB Signal - sarbcf_lpfv_buffer_size1[3:0]
11:0	RO	000h	Core	Reserved (RSVD):

LPFCREG03 - Error Reporting Reg Slice 0

B/D/F/Type: 0/0/0/SARBunit_Confi
 9
Address Offset: B0F8-B0FBh
Default Value: 00000000h
Access: RO; RWC;
Size: 32 bits

This register is not ctx saved/restored.

Bit	Access	Default Value	RST/PWR	Description
31:5	RO	0000000h	Core	Reserved (RSVD):
4	RWC	0b	Core	First Content Buffer Ready 0 (FRSNTBFR0):



Bit	Access	Default Value	RST/PWR	Description
				<p>First Content Buffer Ready: This bits gets set by the h/w when the buffer is completely filled up and cleared by the driver when the contents of this buffer is copied out of memory.</p> <p>Will be set by lpfc_sarbcf_buffer0_ready (pulse) sarbcf_lpfc_buffer0_ready (static signal to lpfc)</p>
3	RWC	0b	Core	<p>Second Content Buffer Ready slice 0 (SCNBFR0):</p> <p>Second Content Buffer Ready: This bits gets set by the h/w when the buffer is completely filled up and cleared by the driver when the contents of this buffer is copied out of memory.</p> <p>Will be set by lpfc_sarbcf_buffer1_ready(pulse) sarbcf_lpfc_buffer1_ready (static signal to lpfc)</p>
2	RWC	0b	Core	<p>Write Expired Error slice 0 (WEERR0):</p> <p>Write Expired Error: If DMA controller could not get a chance to push the write of 64Bytes to GAPL3 and data get clobbered with the new expiration of the save timer, this error bit will be set to indicate something went wrong.</p> <p>Signal - lpfc_sarbcf_wrexp_error</p>
1	RWC	0b	Core	<p>Buffer full Error Slice 0 (BFFLERR0):</p> <p>Set by lpfc_sarbcf_error_buffer_full</p> <p>When both buffers are full lpfc will set this bit or if only 1 buffer is enabled then lpfc will set this bit when the buffer is full.</p>
0	RO	0b	Core	Reserved (RSVD):

LPFCREG04 - Frame count and Draw call number

B/D/F/Type: 0/0/0/SARBunit_Confi
g

Address Offset: B0FC-B0FFh

Default Value: 00000000h

Access: RO; RW;

Size: 32 bits

Bit	Access	Default Value	RST/PWR	Description
-----	--------	---------------	---------	-------------



Bit	Access	Default Value	RST/PWR	Description
31:16	RO	0000h	Core	Reserved (RSVD):
15:8	RW	00h	Core	<p>Frame Number (FRMNUM):</p> <p>Frame Number: This field is for GFX driver to populate the Frame number (or Frame color). It is an optional field for s/w to select the data samples that belongs to different frames. This 8-bit field can be incremented by the driver at every frame boundary.</p> <p>The frame number recording is an option with the counter selects.</p> <p>Signal - sarbcf_lpfcr_frame_num[7:0]</p>
7:0	RW	00h	Core	<p>Draw Call Number (DRWCLNUM):</p> <p>Draw Call Number: It is theoretically possible for s/w to increment a count with each draw call submission, which in turn can be reported out as part of the data stream.</p> <p>Signal - sarbcf_lpfcr_drawcall_num[7:0]</p>

LPFCREG05 - SAVE Timer

B/D/F/Type: 0/0/0/SARBunit_Confi
g

Address Offset: B100-B103h

Default Value: 00000000h

Access: RO; RW;

Size: 32 bits

Bit	Access	Default Value	RST/PWR	Description
31	RO	0b	Core	Reserved (RSVD):
30:29	RW	11b	Core	<p>Counter ENabling Selection (CNTRENSEL):</p> <p>Counter Enabling Selection: Enables different number of counters aiding in data compression for focused studies</p> <p>00 : Only Counter#0 is enabled</p> <p>01 : Counters #0 & #1 are enabled</p> <p>10 : Counters #0, #1, #2 and #3 are enabled</p> <p>11 : All counters are enabled</p>



Bit	Access	Default Value	RST/PWR	Description
				Signal - sarbcf_lpf_cnt_enabled[1:0]
28:24	RO	00000b	Core	Reserved (RSVD):
23:0	RW	001000h	Core	<p>Save Timer Interval (SVTMRINT):</p> <p>Save Timer Interval: This is the interval for sampling the performance counters and writing to memory. Each time it expires, the counters will be sampled and packetized to be sent to DMA controller.</p> <p>The minimum granularity of sampling period is 256clocks. The value in this register is used as 256 x value to find the sampling window. For a 1Ghz core clock it provides up to 4ns of sampling period while matching the maximum capability of the event counters.</p> <p>1-256clks 2-512clks ...so on 8-2048clks</p> <p>Signal - sarbcf_lpf_savetimer_int[23:0]</p>

L3 Performance Counter Event Table

Client Encoding	hex
GAFS Rd	00
GAFS Wr	01
HDC0 Data Rd	02
HDC0 Const Rd	03
HDC0 URB Rd	04
HDC0 Data Wr	05
HDC0 URB Wr	06
HDC1 Data Rd	07
HDC1 Const Rd	08
HDC1 URB Rd	09
HDC1 Data Wr	0A
HDC1 URB Wr	0B
TDL0 Rd	0C
TDL1 Rd	0D
Tex0 Rd	0E



Client Encoding	hex
Tex1 Rd	0F
Tex2 Rd (reserved)	10
Tex3 Rd (reserved)	11
SBE Rd	12
IC0 Rd	13
IC1 Rd	14
SARB Rd	15
Aggregated Tex	16
SLM0 Rd	17
SLM1 Rd	18
SLM0 Wr	19
SLM1 Wr	1A
SLM0 Atomics	1B
SLM1 Atomics	1C
Reserved	1D
Reserved	1E
Reserved	1F
FF Stalls	20
HDC Stalls	21
TDL Stalls	22
Texture Stalls	23
IC Stalls	24
SBE Stalls	25
SLM Stalls	26
Bank0 Total Hits	40
Bank0 Total Cycles	41
Bank0 Total Rds	42
Bank0 Total Wrs	43
Bank0 FF Rds	44
Bank0 FF Wrs	45
Bank0 DC Rds	46
Bank0 DC Wrs	47
Bank0 DC Hits	48
rsvd	49
Bank0 Tex Rds	4A
Bank0 Tex Hits	AB



Client Encoding	hex
Bank0 IC Rds	AC
Bank0 IC Hits	4D
Reserved	4E
Reserved	4F
Bank1 Events	50-5F (except 59-reserved)
Bank2 Events	60-6F(except 69-reserved)
Bank3 Events	70-7F(except 79-reserved)
MSC Rd	80
MSC Wr	81
STC Rd	82
STC Wr	83
Hiz Rd	84
Hiz Wr	85
RCZ Rd	86
RCZ Wr	87
RCC Rd	88
RCC Wr	89
Frame Number	F0
Draw call number	F1

LPFCREG06 - Event selection and base counters

B/D/F/Type: 0/0/0/SARBunit_Config

Address Offset: B104-B107h

Default Value: 00000000h

Access: RW;

Size: 32 bits

Bit	Access	Default Value	RST/PWR	Description
31:24	RW	00h	Core	Counter 7 client (CNT7CL): sarbcb_lpfcb_cnt7_client[7:0] Counter#0 Client Selection: This field controls which client's request stream will be observed in counter#0



Bit	Access	Default Value	RST/PWR	Description
				Please refer to the <i>L3 Performance Counter Event Table</i> for definition of encodings.
23:16	RW	00h	Core	<p>Counter 6 client (CNT6CL): sarbcf_lpfc_cnt6_client[7:0]</p> <p>Counter#1 Client Selection: This field controls which client's request stream will be observed in counter#1</p> <p>Please refer to the <i>L3 Performance Counter Event Table</i> for definition of encodings.</p>
15:8	RW	00h	Core	<p>Counter 5 client (CNT5CL): sarbcf_lpfc_cnt5_client[7:0]</p> <p>Counter#2 Client Selection: This field controls which client's request stream will be observed in counter#2</p> <p>Please refer to the <i>L3 Performance Counter Event Table</i> for definition of encodings.</p>
7:0	RW	00h	Core	<p>Counter 4 client (CNT4CL): sarbcf_lpfc_cnt4_client[7:0]</p> <p>Counter#3 Client Selection: This field controls which client's request stream will be observed in counter#3</p> <p>Please refer to the <i>L3 Performance Counter Event Table</i> for definition of encodings.</p>



LPFCREG07 - Event Selection and Base Counters1

B/D/F/Type: 0/0/0/SARBunit_Config

Address Offset: B108-B10Bh

Default Value: 00000000h

Access: RW;

Size: 32 bits

Bit	Access	Default Value	RST/PWR	Description
31:24	RW	00h	Core	<p>Counter 3 client (CNT3CL): sarbcf_lpfc_cnt3_client[7:0]</p> <p>Counter#4 Client Selection: This field controls which client's request stream will be observed in counter#4</p> <p>Please refer to the <i>L3 Performance Counter Event Table</i> for definition of encodings.</p>
23:16	RW	00h	Core	<p>Counter 2 client (CNT2CL): sarbcf_lpfc_cnt2_client[7:0]</p> <p>Counter#5 Client Selection: This field controls which client's request stream will be observed in counter#5</p> <p>Please refer to the <i>L3 Performance Counter Event Table</i> for definition of encodings.</p>
15:8	RW	00h	Core	<p>Counter 1 Client (CNT1CL): sarbcf_lpfc_cnt1_client[7:0]</p> <p>Counter#6 Client Selection: This field controls which client's request stream will be observed in counter#6</p> <p>Please refer to the <i>L3 Performance Counter Event Table</i> for definition of encodings.</p>
7:0	RW	00h	Core	<p>Counter0 Client (CNT0CL): sarbcf_lpfc_cnt0_client[7:0]</p> <p>Counter#7 Client Selection: This field controls which client's request stream will be observed in counter#7</p> <p>Please refer to the <i>L3 Performance Counter Event Table</i> for definition of encodings.</p>



LPFCREG08 - MASTER start Timer

B/D/F/Type: 0/0/0/SARBunit_Confi
 g
Address Offset: B10C-B10Fh
Default Value: 00000000h
Access: RW;
Size: 32 bits

Bit	Access	Default Value	RST/PWR	Description
31:0	RW	00000001h	Core	Master Start Timer (MSTSTTMR): sarbcf_lpfc_master_start_timer[31:0] So many clocks are expired before starting the rest of the counters. Time to wait is 256 * value clocks value for this register cannot be 0.

L3SYNC - L3 Cross Sync Control Register

B/D/F/Type: 0/0/0/SARBunit_Confi
 g
Address Offset: B1F4-B1F7h
Default Value: 00000000h
Access: RO; RWHC;
Size: 32 bits

Bit	Access	Default Value	RST/PWR	Description
31:1	RO	00000000h	Core	Reserved (RSVD):
0	RWHC	0b	Core	Cross SYNC of L3 (CRSYNL3): Cross SYNC of L3: This is a message bit written by the cross L3 in case of GT4. To set this bit both bit[0] and bit[16] (mask) needs to be set. This bit stays set until the targeted L3 sends its SYNC FLUSH COMPLETE EVENT to HDC.



slmmsg - slm context save/restore msg

B/D/F/Type: 0/0/0/SARBunit_Confi
 g
Address Offset: B1F8-B1FBh
Default Value: 00000000h
Access: RO; RWHC;
Size: 32 bits

This register is written by tsg unit and is not ctx saved

Bit	Access	Default Value	RST/PWR	Description
31:10	RO	000000h	Core	Reserved (RSVD): Reserved
9:2	RO	00h	Core	Reserved (RSVD):
1	RWHC	0b	Core	SLM restore msg (SLMRSTR): Restore - When set, TSG is requesting for restore of SLM from the address provided.
0	RWHC	0b	Core	slm save msg (SLMSVMSG): SAve - When set, TSG is requesting for save of SLM to the address provided.

SARBCSR - SARB config save msg

B/D/F/Type: 0/0/0/SARBunit_Confi
 g
Address Offset: B1FC-B1FFh
Default Value: 00000000h
Access: RWHC; RO;
Size: 32 bits

this register is not context saved and is written by cs unit

Bit	Access	Default Value	RST/PWR	Description
31:2	RO	00000000h	Core	Reserved (RSVD):
1	RWHC	0b	Core	Context restore ack (CTXRSTRACK): A write from cs to this bit along with mask bit 17 will prompt sarb to ack ctx restore ack . sarb_ctx_restore - ctx restore from cs



Bit	Access	Default Value	RST/PWR	Description
				clr_sarb_ctx_restore - sarb clr this bit.
0	RWHC	0b	Core	<p>Context save bit (SARBCS):</p> <p>A write from cs to this bit along with mask bit 16 will prompt sarb to start context save to cs.</p> <p>sarb_ctx_save - ctx save from cs</p> <p>clr_sarb_ctx_save - sarb clr this bit once ctx save sm kicks in .</p>

SARERRST1 - SARB Error Status slice1

B/D/F/Type: 0/0/0/SARBunit_Confi
g

Address Offset: B204-B207h

Default Value: 00000000h

Access: RO;

Size: 32 bits

Reports the error if any has occurred for certain sarb features.

This register is not ctx saved

Bit	Access	Default Value	RST/PWR	Description
31	RO	0b	Core	<p>Error if general bound is zero (ERRGENBDZO):</p> <p>Error if general bound is zero set by sarbunit</p> <p>1: general bound address is 0</p> <p>sarbcf_csr_gen_bnd_zero_err</p>
30	RO	0b	Core	<p>Error if dynamic bound is zero (ERRDYDNZO):</p> <p>Error if dynamic bound is zero- set by sarbunit</p> <p>0:no error</p> <p>1: dynamic address is 0</p> <p>sarbcf_csr_dyn_bnd_zero_err</p>
29	RO	0b	Core	Reserved (RSVD):
28	RO	0b	Core	General Bound Check Overflow Error (GENBNDOVF):



Bit	Access	Default Value	RST/PWR	Description
				General Bound Check Overflow Error - set by sarbunit 1: overflow for general bound check sarbcf_csr_gen_bnd_ovflw_err
27	RO	0b	Core	Dynamic Bound Check Overflow Error (DYNBDOVF): Dynamic Bound Check Overflow Error -set by sarbunit 1: overflow for dynamic bound check sarbcf_csr_dyn_bnd_ovflw_err
26	RO	0b	Core	Lower Bound Check Overflow Error (LWRBDOVF): Lower Bound Check Overflow Error-set by sarbunit lower bound overflow sarbcf_csr_lower_bnd_err
25:21	RO	00000b	Core	INVALIDATION FLUSH STATUS REPORTING (INVSTRPT): invalidation status for I3 is reported in this register.
20:18	RO	000b	Core	SARB invalidation Status reporting (SARBINVSTRPT): invalidation status of sarb is reported in this register.
17	RO	0b	Core	HW surface Bound Check Overflow Error (HWSBDOVF): sarbcf_csr_hw_surf_bnd_ovflw_err HW Surface Bound Check Overflow Error -set by sarbunit 1: overflow for bound check
16	RO	0b	Core	Error if hw surface bound is zero (ERRHWSNZO): sarbcf_csr_hw_surf_bnd_zero_err Error if hw surface bound is zero- set by sarbunit 0:no error 1: address is 0
15	RO	0b	Core	buffer Ready intp err (INTPERR): When both buffers are ready before one buffer ready is cleared by sft sarb will generate intp err (it is not expected that second buffer ready should assert while first buffer ready was not cleared by sftwr.) sarbcf_both_buffer_rd_intp_err
14:0	RO	0000h	Core	Reserved (RSVD):



Bit	Access	Default Value	RST/PWR	Description
				Reserved

L3CDERRST11 - L3CD Error Status register 1 slice 1

B/D/F/Type: 0/0/0/SARBunit_Confi
g

Address Offset: B208-B20Bh

Default Value: 00000000h

Access: RWC; RO;

Size: 32 bits

Bit	Access	Default Value	RST/PWR	Description
31:25	RO	0000000b	Core	Reserved (RSVD): Reserved
24:14	RWC	00000000000b	Core	Parity row address error (PRTYROWNUM): Data array address which has parity B1: Report the data array address which has the Error Itcd_sarb_parity_err_rownum[10:0] Once set by HW, it can be cleared only by MMIO Write of 1 to this register bit 13 .
13	RWC	0b	Core	Parity Error Valid (PRTYERRVLD): Parity Error valid Report the Parity Error Itcd_sarb_parity_err_valid Once set by HW, it can be cleared only by MMIO Write of 1 to this register bit 13 .
12:11	RWC	00b	Core	Parity error bank number (PRTYBNKNUM): bank number which has parity error Report the bank no. which has the Error Itcd_sarb_parity_err_banknum[1:0] Once set by HW, it can be cleared only by MMIO Write of 1 to this register bit 13 .
10:8	RWC	000b	Core	Parity Error sub-bank no (PRTYSBNKNUM):



Bit	Access	Default Value	RST/PWR	Description
				Parity Error in sub bank: ltcd0_sarb_parity_err_subbanknum[2:0] Once set by HW, it can be cleared only by MMIO Write of 1 to this register bit 13 .
7	RO	0b	Core	RESERVED (RSVD): reserved
6:0	RO	00h	Core	Reserved (RSVD):

L3CDERRST12 - L3CD Error Status register 2 slice 1

B/D/F/Type: 0/0/0/SARBunit_Config

Address Offset: B20C-B20Fh

Default Value: 00000000h

Access: RO; RWC;

Size: 32 bits

Bit	Access	Default Value	RST/PWR	Description
31:29	RO	000b	Core	Reserved (RSVD): reserved
28	RWC	0b	Core	URB High Limit Error on B3 (URBHLB3): URB High Limit Error on B3: Report the URB High Limit Error- Address Bound check Once set, it can be cleared only by MMIO Write to this register. A write of value 1 will clear it (LTCC generates a Pulse to SARB Config , Sarb Config sets and reflect it in the MMIO as Error status. This can be only cleared by MMIO Write to that Bit.) ltcc3_sarb_urboff_error
27	RWC	0b	Core	URB High Limit Error on B2 (URBHLB2): URB High Limit Error on B2: Report the URB High Limit Error- Address Bound check Once set, it can be cleared only by MMIO Write to this register. (LTCC generates a Pulse to SARB Config , Sarb Config sets and reflect it in



Bit	Access	Default Value	RST/PWR	Description
				the MMIO as Error status. This can be only cleared by MMIO Write to that Bit.) ltcc2_sarb_urboff_error
26	RWC	0b	Core	URB High Limit Error on B1 (URBHLB1): URB High Limit Error on B1: Report the URB High Limit Error - Address Bound check Once set, it can be cleared only by MMIO Write to this register. (LTCC generates a Pulse to SARB Config , Sarb Config sets and reflect it in the MMIO as Error status. This can be only cleared by MMIO Write to that Bit.) ltcc1_sarb_urboff_error
25	RWC	0b	Core	URB High Limit Error on B0 (URBHLB0): URB High Limit Error on B0 : Report the URB High Limit Error - Address Bound check Once set, it can be cleared only by MMIO Write to this register. (LTCC generates a Pulse to SARB Config , Sarb Config sets and reflect it in the MMIO as Error status. This can be only cleared by MMIO Write to that Bit.) ltcc0_sarb_urboff_error
24:0	RO	0000000h	Core	Reserved (RSVD):

CLMREDS1 - Column Redundancy Slice 1

B/D/F/Type:

0/0/0/SARBunit_Config

Address Offset:

B244-B247h

Default Value:

00000000h

Access:

RW; RO;

Size:

32 bits

This register is written by mbcunit and is not ctx saved

Bit	Access	Default Value	RST/PWR	Description
31:25	RW	00h	Core	column redundancy bank 0 (CRB0):



Bit	Access	Default Value	RST/PWR	Description
				sarb_ltc0_fuse[6:0]
24:18	RW	00h	Core	column redundancy bank1 (CRB1): sarb_ltc1_fuse[6:0]
17:11	RW	00h	Core	column redundancy bank 2 (CRB2): sarb_ltc2_fuse[6:0]
10:4	RW	00h	Core	column redundancy bank 3 (CRB3): sarb_ltc3_fuse[6:0]
3:0	RO	0000b	Core	Reserved (RSVD):

LPCNTR1S1 - LPFC counter reg01 slice 1

B/D/F/Type: 0/0/0/SARBunit_Confi
g
Address Offset: B24C-B24Fh
Default Value: 00000000h
Access: RO;
Size: 32 bits

Counter 0

Bit	Access	Default Value	RST/PWR	Description
31:0	RO	00000000h	Core	LPFC Counter 1 slice 1 (LPFCNT11): Counter 1

LPCNTR2S1 - LPFC counter reg02 slice 1

B/D/F/Type: 0/0/0/SARBunit_Confi
g
Address Offset: B250-B253h
Default Value: 00000000h
Access: RO;
Size: 32 bits

Bit	Access	Default Value	RST/PWR	Description
31:0	RO	00000000h	Core	LPFC Counter 2 slice 1 (LPFCNT12): counter2



LPCNTR3S1 - LPFC counter reg03 slice 1

B/D/F/Type: 0/0/0/SARBunit_Confi
g
Address Offset: B254-B257h
Default Value: 00000000h
Access: RO;
Size: 32 bits

Bit	Access	Default Value	RST/PWR	Description
31:0	RO	00000000h	Core	LPFC Counter 3 slice 1 (LPFCCNT13): counter3

LPCNTR4S1 - LPFC counter reg04 slice 1

B/D/F/Type: 0/0/0/SARBunit_Confi
g
Address Offset: B258-B25Bh
Default Value: 00000000h
Access: RO;
Size: 32 bits

Bit	Access	Default Value	RST/PWR	Description
31:0	RO	00000000h	Core	LPFC Counter 4 slice 1 (LPFCCNT14): counter4

LPCNTR5S1 - LPFC counter reg05 slice 1

B/D/F/Type: 0/0/0/SARBunit_Confi
g
Address Offset: B25C-B25Fh
Default Value: 00000000h
Access: RO;
Size: 32 bits

Bit	Access	Default Value	RST/PWR	Description
31:0	RO	00000000h	Core	LPFC Counter 5 slice 1 (LPFCCNT15): Counter5

LPCNTR6S1 - LPFC counter reg06 slice 1

B/D/F/Type: 0/0/0/SARBunit_Confi



g
Address Offset: B260-B263h
Default Value: 00000000h
Access: RO;
Size: 32 bits

Bit	Access	Default Value	RST/PWR	Description
31:0	RO	00000000h	Core	LPFC Counter 6 slice 1 (LPFCNT16): Counter6

LPCNTR7S1 - LPFC counter reg07 slice 1

B/D/F/Type: 0/0/0/SARBunit_Confi
g
Address Offset: B264-B267h
Default Value: 00000000h
Access: RO;
Size: 32 bits

Bit	Access	Default Value	RST/PWR	Description
31:0	RO	00000000h	Core	LPFC Counter 7 slice 1 (LPFCNT17): counter7

L3B0REG10 - L3 bank0 reg0 log error slice 1

B/D/F/Type: 0/0/0/SARBunit_Confi
g
Address Offset: B270-B273h
Default Value: 00000000h
Access: WO; RO;
Size: 32 bits

The ERROR LOG registers of L3 will maintain the bad row information for each of the 16KB subbank groups. The LOG will be programmed by driver before any workloads are submitted.

The contents of the LOG register will be context Save&Restored by h/w around rc6 events.

Bit	Access	Default Value	RST/PWR	Description
31:21	WO	000h	Core	Row Number for Error1 (RNUMERR1): Row Number for Error1: The physical row number where the parity error has been detected. The



Bit	Access	Default Value	RST/PWR	Description
				number of rows vary between 4K vs 8K/16K subbanks which requires 10bits vs 11bits respectively. This field contains the row# with the error
20:17	RO	0000b	Core	Reserved (RSVD):
16	WO	0b	Core	Valid Error 1 (VLDERR1): Valid Error: The error located in field 15:5 is valid and corresponding logical 16KB group should bypass this row.
15:5	WO	000h	Core	Row Number for Error0 (RNUMERR0): Row Number for Error0: The physical row number where the parity error has been detected. The number of rows vary between 4K vs 8K/16K subbanks which requires 10bits vs 11bits respectively. This field contains the row# with the error
4:1	RO	0000b	Core	Reserved (RSVD):
0	WO	0b	Core	Valid Error 0 (VLDERR0): Valid Error: The error located in field 15:5 is valid and corresponding logical 16KB group should bypass this row.

L3B0REG11 - L3 bank0 reg1 log error slice 1

B/D/F/Type: 0/0/0/SARBunit_Confi
g

Address Offset: B274-B277h

Default Value: 00000000h

Access: WO; RO;

Size: 32 bits

The ERROR LOG registers of L3 will maintain the bad row information for each of the 16KB subbank groups. The LOG will be programmed by driver before any workloads are submitted.

The contents of the LOG register will be context Save&Restored by h/w around rc6 events.



Bit	Access	Default Value	RST/PWR	Description
31:21	WO	000h	Core	Row Number for Error1 (RNUMERR1): Row Number for Error1: The physical row number where the parity error has been detected. The number of rows vary between 4K vs 8K/16K subbanks which requires 10bits vs 11bits respectively. This field contains the row# with the error
20:17	RO	0000b	Core	Reserved (RSVD):
16	WO	0b	Core	Valid Error 1 (VLDERR1): Valid Error: The error located in field 15:5 is valid and corresponding logical 16KB group should bypass this row.
15:5	WO	000h	Core	Row Number for Error0 (RNUMERR0): Row Number for Error0: The physical row number where the parity error has been detected. The number of rows vary between 4K vs 8K/16K subbanks which requires 10bits vs 11bits respectively. This field contains the row# with the error
4:1	RO	0000b	Core	Reserved (RSVD):
0	WO	0b	Core	Valid Error 0 (VLDERR0): Valid Error: The error located in field 15:5 is valid and corresponding logical 16KB group should bypass this row.

L3B0REG12 - L3 bank0 reg2 log error slice 1

B/D/F/Type: 0/0/0/SARBunit_Config
Address Offset: B278-B27Bh
Default Value: 00000000h
Access: RO; WO;
Size: 32 bits



The ERROR LOG registers of L3 will maintain the bad row information for each of the 16KB subbank groups. The LOG will be programmed by driver before any workloads are submitted.

The contents of the LOG register will be context Save&Restored by h/w around rc6 events.

Bit	Access	Default Value	RST/PWR	Description
31:21	WO	000h	Core	Row Number for Error1 (RNUMERR1): Row Number for Error1: The physical row number where the parity error has been detected. The number of rows vary between 4K vs 8K/16K subbanks which requires 10bits vs 11bits respectively. This field contains the row# with the error
20:17	RO	0000b	Core	Reserved (RSVD):
16	WO	0b	Core	Valid Error 1 (VLDERR1): Valid Error: The error located in field 15:5 is valid and corresponding logical 16KB group should bypass this row.
15:5	WO	000h	Core	Row Number for Error0 (RNUMERR0): Row Number for Error0: The physical row number where the parity error has been detected. The number of rows vary between 4K vs 8K/16K subbanks which requires 10bits vs 11bits respectively. This field contains the row# with the error
4:1	RO	0000b	Core	Reserved (RSVD):
0	WO	0b	Core	Valid Error 0 (VLDERR0): Valid Error: The error located in field 15:5 is valid and corresponding logical 16KB group should bypass this row.

L3B0REG13 - L3 bank0 reg3 log error slice 1

B/D/F/Type: 0/0/0/SARBunit_Confi
g

Address Offset: B27C-B27Fh

Default Value: 00000000h



Access: WO; RO;

Size: 32 bits

The ERROR LOG registers of L3 will maintain the bad row information for each of the 16KB subbank groups. The LOG will be programmed by driver before any workloads are submitted.

The contents of the LOG register will be context Save&Restored by h/w around rc6 events.

Bit	Access	Default Value	RST/PWR	Description
31:21	WO	000h	Core	Row Number for Error1 (RNUMERR1): Row Number for Error1: The physical row number where the parity error has been detected. The number of rows vary between 4K vs 8K/16K subbanks which requires 10bits vs 11bits respectively. This field contains the row# with the error
20:17	RO	0000b	Core	Reserved (RSVD):
16	WO	0b	Core	Valid Error 1 (VLDERR1): Valid Error: The error located in field 15:5 is valid and corresponding logical 16KB group should bypass this row.
15:5	WO	000h	Core	Row Number for Error0 (RNUMERR0): Row Number for Error0: The physical row number where the parity error has been detected. The number of rows vary between 4K vs 8K/16K subbanks which requires 10bits vs 11bits respectively. This field contains the row# with the error
4:1	RO	0000b	Core	Reserved (RSVD):
0	WO	0b	Core	Valid Error 0 (VLDERR0): Valid Error: The error located in field 15:5 is valid and corresponding logical 16KB group should bypass this row.

L3B0REG14 - L3 bank0 reg4 log error slice1

B/D/F/Type: 0/0/0/SARBunit_Confi



g

Address Offset: B280-B283h
Default Value: 00000000h
Access: RO; WO;
Size: 32 bits

The ERROR LOG registers of L3 will maintain the bad row information for each of the 16KB subbank groups. The LOG will be programmed by driver before any workloads are submitted.

The contents of the LOG register will be context Save&Restored by h/w around rc6 events.

Bit	Access	Default Value	RST/PWR	Description
31:21	WO	000h	Core	Row Number for Error1 (RNUMERR1): Row Number for Error1: The physical row number where the parity error has been detected. The number of rows vary between 4K vs 8K/16K subbanks which requires 10bits vs 11bits respectively. This field contains the row# with the error
20:17	RO	0000b	Core	Reserved (RSVD):
16	WO	0b	Core	Valid Error 1 (VLDERR1): Valid Error: The error located in field 15:5 is valid and corresponding logical 16KB group should bypass this row.
15:5	WO	000h	Core	Row Number for Error0 (RNUMERR0): Row Number for Error0: The physical row number where the parity error has been detected. The number of rows vary between 4K vs 8K/16K subbanks which requires 10bits vs 11bits respectively. This field contains the row# with the error
4:1	RO	0000b	Core	Reserved (RSVD):
0	WO	0b	Core	Valid Error 0 (VLDERR0): Valid Error: The error located in field 15:5 is valid and corresponding logical 16KB group should bypass this row.



L3B0REG15 - L3 bank0 reg5 log error slice1

B/D/F/Type: 0/0/0/SARBunit_Confi
 g
Address Offset: B284-B287h
Default Value: 00000000h
Access: WO; RO;
Size: 32 bits

The ERROR LOG registers of L3 will maintain the bad row information for each of the 16KB subbank groups. The LOG will be programmed by driver before any workloads are submitted.

The contents of the LOG register will be context Save&Restored by h/w around rc6 events.

Bit	Access	Default Value	RST/PWR	Description
31:21	WO	000h	Core	Row Number for Error1 (RNUMERR1): Row Number for Error1: The physical row number where the parity error has been detected. The number of rows vary between 4K vs 8K/16K subbanks which requires 10bits vs 11bits respectively. This field contains the row# with the error
20:17	RO	0000b	Core	Reserved (RSVD):
16	WO	0b	Core	Valid Error 1 (VLDERR1): Valid Error: The error located in field 15:5 is valid and corresponding logical 16KB group should bypass this row.
15:5	WO	000h	Core	Row Number for Error0 (RNUMERR0): Row Number for Error0: The physical row number where the parity error has been detected. The number of rows vary between 4K vs 8K/16K subbanks which requires 10bits vs 11bits respectively. This field contains the row# with the error
4:1	RO	0000b	Core	Reserved (RSVD):
0	WO	0b	Core	Valid Error 0 (VLDERR0): Valid Error:



Bit	Access	Default Value	RST/PWR	Description
				The error located in field 15:5 is valid and corresponding logical 16KB group should bypass this row.

L3B0REG16 - L3 bank0 reg6 log error slice 1

B/D/F/Type: 0/0/0/SARBunit_Confi
 g
Address Offset: B288-B28Bh
Default Value: 00000000h
Access: WO; RO;
Size: 32 bits

The ERROR LOG registers of L3 will maintain the bad row information for each of the 16KB subbank groups. The LOG will be programmed by driver before any workloads are submitted.

The contents of the LOG register will be context Save&Restored by h/w around rc6 events.

Bit	Access	Default Value	RST/PWR	Description
31:21	WO	000h	Core	Row Number for Error1 (RNUMERR1): Row Number for Error1: The physical row number where the parity error has been detected. The number of rows vary between 4K vs 8K/16K subbanks which requires 10bits vs 11bits respectively. This field contains the row# with the error
20:17	RO	0000b	Core	Reserved (RSVD):
16	WO	0b	Core	Valid Error 1 (VLDERR1): Valid Error: The error located in field 15:5 is valid and corresponding logical 16KB group should bypass this row.
15:5	WO	000h	Core	Row Number for Error0 (RNUMERR0): Row Number for Error0: The physical row number where the parity error has been detected. The number of rows vary between 4K vs 8K/16K subbanks which requires 10bits vs 11bits respectively. This field contains the row# with the error



Bit	Access	Default Value	RST/PWR	Description
4:1	RO	0000b	Core	Reserved (RSVD):
0	WO	0b	Core	Valid Error 0 (VLDERR0): Valid Error: The error located in field 15:5 is valid and corresponding logical 16KB group should bypass this row.

L3B0REG17 - L3 bank0 reg7 log error slice1

B/D/F/Type: 0/0/0/SARBunit_Confi
g

Address Offset: B28C-B28Fh

Default Value: 00000000h

Access: WO; RO;

Size: 32 bits

The ERROR LOG registers of L3 will maintain the bad row information for each of the 16KB subbank groups. The LOG will be programmed by driver before any workloads are submitted.

The contents of the LOG register will be context Save&Restored by h/w around rc6 events.

Bit	Access	Default Value	RST/PWR	Description
31:21	WO	000h	Core	Row Number for Error1 (RNUMERR1): Row Number for Error1: The physical row number where the parity error has been detected. The number of rows vary between 4K vs 8K/16K subbanks which requires 10bits vs 11bits respectively. This field contains the row# with the error
20:17	RO	0000b	Core	Reserved (RSVD):
16	WO	0b	Core	Valid Error 1 (VLDERR1): Valid Error: The error located in field 15:5 is valid and corresponding logical 16KB group should bypass this row.
15:5	WO	000h	Core	Row Number for Error0 (RNUMERR0):



Bit	Access	Default Value	RST/PWR	Description
				<p>Row Number for Error0:</p> <p>The physical row number where the parity error has been detected. The number of rows vary between 4K vs 8K/16K subbanks which requires 10bits vs 11bits respectively.</p> <p>This field contains the row# with the error</p>
4:1	RO	0000b	Core	Reserved (RSVD):
0	WO	0b	Core	<p>Valid Error 0 (VLDERR0):</p> <p>Valid Error:</p> <p>The error located in field 15:5 is valid and corresponding logical 16KB group should bypass this row.</p>

L3B1REG10 - L3 bank1 reg0 log error slice 1

B/D/F/Type: 0/0/0/SARBunit_Confi
g

Address Offset: B290-B293h

Default Value: 00000000h

Access: WO; RO;

Size: 32 bits

The ERROR LOG registers of L3 will maintain the bad row information for each of the 16KB subbank groups. The LOG will be programmed by driver before any workloads are submitted.

The contents of the LOG register will be context Save&Restored by h/w around rc6 events.

Bit	Access	Default Value	RST/PWR	Description
31:21	WO	000h	Core	<p>Row Number for Error1 (RNUMERR1):</p> <p>Row Number for Error1:</p> <p>The physical row number where the parity error has been detected. The number of rows vary between 4K vs 8K/16K subbanks which requires 10bits vs 11bits respectively.</p> <p>This field contains the row# with the error</p>
20:17	RO	0000b	Core	Reserved (RSVD):
16	WO	0b	Core	Valid Error 1 (VLDERR1):



Bit	Access	Default Value	RST/PWR	Description
				Valid Error: The error located in field 15:5 is valid and corresponding logical 16KB group should bypass this row.
15:5	WO	000h	Core	Row Number for Error0 (RNUMERR0): Row Number for Error0: The physical row number where the parity error has been detected. The number of rows vary between 4K vs 8K/16K subbanks which requires 10bits vs 11bits respectively. This field contains the row# with the error
4:1	RO	0000b	Core	Reserved (RSVD):
0	WO	0b	Core	Valid Error 0 (VLDERR0): Valid Error: The error located in field 15:5 is valid and corresponding logical 16KB group should bypass this row.



L3B1REG11 - L3 bank1 reg1 log error slice 1

B/D/F/Type: 0/0/0/SARBunit_Confi
 g
Address Offset: B294-B297h
Default Value: 00000000h
Access: WO; RO;
Size: 32 bits

The ERROR LOG registers of L3 will maintain the bad row information for each of the 16KB subbank groups. The LOG will be programmed by driver before any workloads are submitted.

The contents of the LOG register will be context Save&Restored by h/w around rc6 events.

Bit	Access	Default Value	RST/PWR	Description
31:21	WO	000h	Core	Row Number for Error1 (RNUMERR1): Row Number for Error1: The physical row number where the parity error has been detected. The number of rows vary between 4K vs 8K/16K subbanks which requires 10bits vs 11bits respectively. This field contains the row# with the error
20:17	RO	0000b	Core	Reserved (RSVD):
16	WO	0b	Core	Valid Error 1 (VLDERR1): Valid Error: The error located in field 15:5 is valid and corresponding logical 16KB group should bypass this row.
15:5	WO	000h	Core	Row Number for Error0 (RNUMERR0): Row Number for Error0: The physical row number where the parity error has been detected. The number of rows vary between 4K vs 8K/16K subbanks which requires 10bits vs 11bits respectively. This field contains the row# with the error
4:1	RO	0000b	Core	Reserved (RSVD):
0	WO	0b	Core	Valid Error 0 (VLDERR0): Valid Error:



Bit	Access	Default Value	RST/PWR	Description
				The error located in field 15:5 is valid and corresponding logical 16KB group should bypass this row.



L3B1REG12 - L3 bank1 reg2 log error slice 1

B/D/F/Type: 0/0/0/SARBunit_Confi
 g
Address Offset: B298-B29Bh
Default Value: 00000000h
Access: WO; RO;
Size: 32 bits

The ERROR LOG registers of L3 will maintain the bad row information for each of the 16KB subbank groups. The LOG will be programmed by driver before any workloads are submitted.

The contents of the LOG register will be context Save&Restored by h/w around rc6 events.

Bit	Access	Default Value	RST/PWR	Description
31:21	WO	000h	Core	Row Number for Error1 (RNUMERR1): Row Number for Error1: The physical row number where the parity error has been detected. The number of rows vary between 4K vs 8K/16K subbanks which requires 10bits vs 11bits respectively. This field contains the row# with the error
20:17	RO	0000b	Core	Reserved (RSVD):
16	WO	0b	Core	Valid Error 1 (VLDERR1): Valid Error: The error located in field 15:5 is valid and corresponding logical 16KB group should bypass this row.
15:5	WO	000h	Core	Row Number for Error0 (RNUMERR0): Row Number for Error0: The physical row number where the parity error has been detected. The number of rows vary between 4K vs 8K/16K subbanks which requires 10bits vs 11bits respectively. This field contains the row# with the error
4:1	RO	0000b	Core	Reserved (RSVD):
0	WO	0b	Core	Valid Error 0 (VLDERR0): Valid Error:



Bit	Access	Default Value	RST/PWR	Description
				The error located in field 15:5 is valid and corresponding logical 16KB group should bypass this row.



L3B1REG13 - L3 bank1 reg3 log error slice 1

B/D/F/Type: 0/0/0/SARBunit_Confi
g
Address Offset: B29C-B29Fh
Default Value: 00000000h
Access: WO; RO;
Size: 32 bits

The ERROR LOG registers of L3 will maintain the bad row information for each of the 16KB subbank groups. The LOG will be programmed by driver before any workloads are submitted.

The contents of the LOG register will be context Save&Restored by h/w around rc6 events.

Bit	Access	Default Value	RST/PWR	Description
31:21	WO	000h	Core	Row Number for Error1 (RNUMERR1): Row Number for Error1: The physical row number where the parity error has been detected. The number of rows vary between 4K vs 8K/16K subbanks which requires 10bits vs 11bits respectively. This field contains the row# with the error
20:17	RO	0000b	Core	Reserved (RSVD):
16	WO	0b	Core	Valid Error 1 (VLDERR1): Valid Error: The error located in field 15:5 is valid and corresponding logical 16KB group should bypass this row.
15:5	WO	000h	Core	Row Number for Error0 (RNUMERR0): Row Number for Error0: The physical row number where the parity error has been detected. The number of rows vary between 4K vs 8K/16K subbanks which requires 10bits vs 11bits respectively. This field contains the row# with the error
4:1	RO	0000b	Core	Reserved (RSVD):
0	WO	0b	Core	Valid Error 0 (VLDERR0): Valid Error:



Bit	Access	Default Value	RST/PWR	Description
				The error located in field 15:5 is valid and corresponding logical 16KB group should bypass this row.

L3B1REG14 - L3 bank1 reg4 log error slice 1

B/D/F/Type: 0/0/0/SARBunit_Confi
g

Address Offset: B2A0-B2A3h

Default Value: 00000000h

Access: WO; RO;

Size: 32 bits

The ERROR LOG registers of L3 will maintain the bad row information for each of the 16KB subbank groups. The LOG will be programmed by driver before any workloads are submitted.

The contents of the LOG register will be context Save&Restored by h/w around rc6 events.

Bit	Access	Default Value	RST/PWR	Description
31:21	WO	000h	Core	Row Number for Error1 (RNUMERR1): Row Number for Error1: The physical row number where the parity error has been detected. The number of rows vary between 4K vs 8K/16K subbanks which requires 10bits vs 11bits respectively. This field contains the row# with the error
20:17	RO	0000b	Core	Reserved (RSVD):
16	WO	0b	Core	Valid Error 1 (VLDERR1): Valid Error: The error located in field 15:5 is valid and corresponding logical 16KB group should bypass this row.
15:5	WO	000h	Core	Row Number for Error0 (RNUMERR0): Row Number for Error0: The physical row number where the parity error has been detected. The number of rows vary between 4K vs 8K/16K subbanks which requires 10bits vs 11bits respectively. This field contains the row# with the error



Bit	Access	Default Value	RST/PWR	Description
4:1	RO	0000b	Core	Reserved (RSVD):
0	WO	0b	Core	Valid Error 0 (VLDERR0): Valid Error: The error located in field 15:5 is valid and corresponding logical 16KB group should bypass this row.

L3B1REG15 - L3 bank1 reg5 log error slice 1

B/D/F/Type: 0/0/0/SARBunit_Confi
g

Address Offset: B2A4-B2A7h

Default Value: 00000000h

Access: WO; RO;

Size: 32 bits

The ERROR LOG registers of L3 will maintain the bad row information for each of the 16KB subbank groups. The LOG will be programmed by driver before any workloads are submitted.

The contents of the LOG register will be context Save&Restored by h/w around rc6 events.

Bit	Access	Default Value	RST/PWR	Description
31:21	WO	000h	Core	Row Number for Error1 (RNUMERR1): Row Number for Error1: The physical row number where the parity error has been detected. The number of rows vary between 4K vs 8K/16K subbanks which requires 10bits vs 11bits respectively. This field contains the row# with the error
20:17	RO	0000b	Core	Reserved (RSVD):
16	WO	0b	Core	Valid Error 1 (VLDERR1): Valid Error: The error located in field 15:5 is valid and corresponding logical 16KB group should bypass this row.
15:5	WO	000h	Core	Row Number for Error0 (RNUMERR0):



Bit	Access	Default Value	RST/PWR	Description
				<p>Row Number for Error0:</p> <p>The physical row number where the parity error has been detected. The number of rows vary between 4K vs 8K/16K subbanks which requires 10bits vs 11bits respectively.</p> <p>This field contains the row# with the error</p>
4:1	RO	0000b	Core	Reserved (RSVD):
0	WO	0b	Core	<p>Valid Error 0 (VLDERR0):</p> <p>Valid Error:</p> <p>The error located in field 15:5 is valid and corresponding logical 16KB group should bypass this row.</p>

L3B1REG16 - L3 bank1 reg6 log error slice 1

B/D/F/Type: 0/0/0/SARBunit_Confi
g

Address Offset: B2A8-B2ABh

Default Value: 00000000h

Access: WO; RO;

Size: 32 bits

The ERROR LOG registers of L3 will maintain the bad row information for each of the 16KB subbank groups. The LOG will be programmed by driver before any workloads are submitted.

The contents of the LOG register will be context Save&Restored by h/w around rc6 events.

Bit	Access	Default Value	RST/PWR	Description
31:21	WO	000h	Core	<p>Row Number for Error1 (RNUMERR1):</p> <p>Row Number for Error1:</p> <p>The physical row number where the parity error has been detected. The number of rows vary between 4K vs 8K/16K subbanks which requires 10bits vs 11bits respectively.</p> <p>This field contains the row# with the error</p>
20:17	RO	0000b	Core	Reserved (RSVD):
16	WO	0b	Core	Valid Error 1 (VLDERR1):



Bit	Access	Default Value	RST/PWR	Description
				Valid Error: The error located in field 15:5 is valid and corresponding logical 16KB group should bypass this row.
15:5	WO	000h	Core	Row Number for Error0 (RNUMERR0): Row Number for Error0: The physical row number where the parity error has been detected. The number of rows vary between 4K vs 8K/16K subbanks which requires 10bits vs 11bits respectively. This field contains the row# with the error
4:1	RO	0000b	Core	Reserved (RSVD):
0	WO	0b	Core	Valid Error 0 (VLDERR0): Valid Error: The error located in field 15:5 is valid and corresponding logical 16KB group should bypass this row.

L3B1REG17 - L3 bank1 reg7 log error slice 1

B/D/F/Type: 0/0/0/SARBunit_Config

Address Offset: B2AC-B2AFh

Default Value: 00000000h

Access: WO; RO;

Size: 32 bits

The ERROR LOG registers of L3 will maintain the bad row information for each of the 16KB subbank groups. The LOG will be programmed by driver before any workloads are submitted.

The contents of the LOG register will be context Save&Restored by h/w around rc6 events.

Bit	Access	Default Value	RST/PWR	Description
31:21	WO	000h	Core	Row Number for Error1 (RNUMERR1): Row Number for Error1: The physical row number where the parity error has been detected. The number of rows vary between 4K vs 8K/16K subbanks which requires 10bits vs 11bits respectively.



Bit	Access	Default Value	RST/PWR	Description
				This field contains the row# with the error
20:17	RO	0000b	Core	Reserved (RSVD):
16	WO	0b	Core	Valid Error 1 (VLDERR1): Valid Error: The error located in field 15:5 is valid and corresponding logical 16KB group should bypass this row.
15:5	WO	000h	Core	Row Number for Error0 (RNUMERR0): Row Number for Error0: The physical row number where the parity error has been detected. The number of rows vary between 4K vs 8K/16K subbanks which requires 10bits vs 11bits respectively. This field contains the row# with the error
4:1	RO	0000b	Core	Reserved (RSVD):
0	WO	0b	Core	Valid Error 0 (VLDERR0): Valid Error: The error located in field 15:5 is valid and corresponding logical 16KB group should bypass this row.



L3B2REG10 - L3 bank2 reg0 log error slice 1

B/D/F/Type: 0/0/0/SARBunit_Confi
g
Address Offset: B2B0-B2B3h
Default Value: 00000000h
Access: WO; RO;
Size: 32 bits

The ERROR LOG registers of L3 will maintain the bad row information for each of the 16KB subbank groups. The LOG will be programmed by driver before any workloads are submitted.

The contents of the LOG register will be context Save&Restored by h/w around rc6 events.

Bit	Access	Default Value	RST/PWR	Description
31:21	WO	000h	Core	Row Number for Error1 (RNUMERR1): Row Number for Error1: The physical row number where the parity error has been detected. The number of rows vary between 4K vs 8K/16K subbanks which requires 10bits vs 11bits respectively. This field contains the row# with the error
20:17	RO	0000b	Core	Reserved (RSVD):
16	WO	0b	Core	Valid Error 1 (VLDERR1): Valid Error: The error located in field 15:5 is valid and corresponding logical 16KB group should bypass this row.
15:5	WO	000h	Core	Row Number for Error0 (RNUMERR0): Row Number for Error0: The physical row number where the parity error has been detected. The number of rows vary between 4K vs 8K/16K subbanks which requires 10bits vs 11bits respectively. This field contains the row# with the error
4:1	RO	0000b	Core	Reserved (RSVD):
0	WO	0b	Core	Valid Error 0 (VLDERR0): Valid Error:



Bit	Access	Default Value	RST/PWR	Description
				The error located in field 15:5 is valid and corresponding logical 16KB group should bypass this row.

L3B2REG11 - L3 bank2 reg1 log error slice 1

B/D/F/Type: 0/0/0/SARBunit_Confi
g

Address Offset: B2B4-B2B7h

Default Value: 00000000h

Access: WO; RO;

Size: 32 bits

The ERROR LOG registers of L3 will maintain the bad row information for each of the 16KB subbank groups. The LOG will be programmed by driver before any workloads are submitted.

The contents of the LOG register will be context Save&Restored by h/w around rc6 events.

Bit	Access	Default Value	RST/PWR	Description
31:21	WO	000h	Core	Row Number for Error1 (RNUMERR1): Row Number for Error1: The physical row number where the parity error has been detected. The number of rows vary between 4K vs 8K/16K subbanks which requires 10bits vs 11bits respectively. This field contains the row# with the error
20:17	RO	0000b	Core	Reserved (RSVD):
16	WO	0b	Core	Valid Error 1 (VLDERR1): Valid Error: The error located in field 15:5 is valid and corresponding logical 16KB group should bypass this row.
15:5	WO	000h	Core	Row Number for Error0 (RNUMERR0): Row Number for Error0: The physical row number where the parity error has been detected. The number of rows vary between 4K vs 8K/16K subbanks which requires 10bits vs 11bits respectively. This field contains the row# with the error



Bit	Access	Default Value	RST/PWR	Description
4:1	RO	0000b	Core	Reserved (RSVD):
0	WO	0b	Core	Valid Error 0 (VLDERR0): Valid Error: The error located in field 15:5 is valid and corresponding logical 16KB group should bypass this row.

L3B2REG12 - L3 bank2 reg2 log error slice 1

B/D/F/Type: 0/0/0/SARBunit_Confi
g

Address Offset: B2B8-B2BBh

Default Value: 00000000h

Access: WO; RO;

Size: 32 bits

The ERROR LOG registers of L3 will maintain the bad row information for each of the 16KB subbank groups. The LOG will be programmed by driver before any workloads are submitted.

The contents of the LOG register will be context Save&Restored by h/w around rc6 events.

Bit	Access	Default Value	RST/PWR	Description
31:21	WO	000h	Core	Row Number for Error1 (RNUMERR1): Row Number for Error1: The physical row number where the parity error has been detected. The number of rows vary between 4K vs 8K/16K subbanks which requires 10bits vs 11bits respectively. This field contains the row# with the error
20:17	RO	0000b	Core	Reserved (RSVD):
16	WO	0b	Core	Valid Error 1 (VLDERR1): Valid Error: The error located in field 15:5 is valid and corresponding logical 16KB group should bypass this row.
15:5	WO	000h	Core	Row Number for Error0 (RNUMERR0):



Bit	Access	Default Value	RST/PWR	Description
				<p>Row Number for Error0:</p> <p>The physical row number where the parity error has been detected. The number of rows vary between 4K vs 8K/16K subbanks which requires 10bits vs 11bits respectively.</p> <p>This field contains the row# with the error</p>
4:1	RO	0000b	Core	Reserved (RSVD):
0	WO	0b	Core	<p>Valid Error 0 (VLDERR0):</p> <p>Valid Error:</p> <p>The error located in field 15:5 is valid and corresponding logical 16KB group should bypass this row.</p>

L3B2REG13 - L3 bank2 reg3 log error slice 1

B/D/F/Type: 0/0/0/SARBunit_Confi
g

Address Offset: B2BC-B2BFh

Default Value: 00000000h

Access: WO; RO;

Size: 32 bits

The ERROR LOG registers of L3 will maintain the bad row information for each of the 16KB subbank groups. The LOG will be programmed by driver before any workloads are submitted.

The contents of the LOG register will be context Save&Restored by h/w around rc6 events.

Bit	Access	Default Value	RST/PWR	Description
31:21	WO	000h	Core	<p>Row Number for Error1 (RNUMERR1):</p> <p>Row Number for Error1:</p> <p>The physical row number where the parity error has been detected. The number of rows vary between 4K vs 8K/16K subbanks which requires 10bits vs 11bits respectively.</p> <p>This field contains the row# with the error</p>
20:17	RO	0000b	Core	Reserved (RSVD):
16	WO	0b	Core	Valid Error 1 (VLDERR1):



Bit	Access	Default Value	RST/PWR	Description
				Valid Error: The error located in field 15:5 is valid and corresponding logical 16KB group should bypass this row.
15:5	WO	000h	Core	Row Number for Error0 (RNUMERR0): Row Number for Error0: The physical row number where the parity error has been detected. The number of rows vary between 4K vs 8K/16K subbanks which requires 10bits vs 11bits respectively. This field contains the row# with the error
4:1	RO	0000b	Core	Reserved (RSVD):
0	WO	0b	Core	Valid Error 0 (VLDERR0): Valid Error: The error located in field 15:5 is valid and corresponding logical 16KB group should bypass this row.

L3B2REG14 - L3 bank2 reg4 log error slice 1

B/D/F/Type: 0/0/0/SARBunit_Config

Address Offset: B2C0-B2C3h

Default Value: 00000000h

Access: WO; RO;

Size: 32 bits

The ERROR LOG registers of L3 will maintain the bad row information for each of the 16KB subbank groups. The LOG will be programmed by driver before any workloads are submitted.

The contents of the LOG register will be context Save&Restored by h/w around rc6 events.

Bit	Access	Default Value	RST/PWR	Description
31:21	WO	000h	Core	Row Number for Error1 (RNUMERR1): Row Number for Error1: The physical row number where the parity error has been detected. The number of rows vary between 4K vs 8K/16K subbanks which requires 10bits vs 11bits respectively.



Bit	Access	Default Value	RST/PWR	Description
				This field contains the row# with the error
20:17	RO	0000b	Core	Reserved (RSVD):
16	WO	0b	Core	Valid Error 1 (VLDERR1): Valid Error: The error located in field 15:5 is valid and corresponding logical 16KB group should bypass this row.
15:5	WO	000h	Core	Row Number for Error0 (RNUMERR0): Row Number for Error0: The physical row number where the parity error has been detected. The number of rows vary between 4K vs 8K/16K subbanks which requires 10bits vs 11bits respectively. This field contains the row# with the error
4:1	RO	0000b	Core	Reserved (RSVD):
0	WO	0b	Core	Valid Error 0 (VLDERR0): Valid Error: The error located in field 15:5 is valid and corresponding logical 16KB group should bypass this row.



L3B2REG15 - L3 bank2 reg5 log error slice 1

B/D/F/Type: 0/0/0/SARBunit_Confi
 g
Address Offset: B2C4-B2C7h
Default Value: 00000000h
Access: WO; RO;
Size: 32 bits

The ERROR LOG registers of L3 will maintain the bad row information for each of the 16KB subbank groups. The LOG will be programmed by driver before any workloads are submitted.

The contents of the LOG register will be context Save&Restored by h/w around rc6 events.

Bit	Access	Default Value	RST/PWR	Description
31:21	WO	000h	Core	Row Number for Error1 (RNUMERR1): Row Number for Error1: The physical row number where the parity error has been detected. The number of rows vary between 4K vs 8K/16K subbanks which requires 10bits vs 11bits respectively. This field contains the row# with the error
20:17	RO	0000b	Core	Reserved (RSVD):
16	WO	0b	Core	Valid Error 1 (VLDERR1): Valid Error: The error located in field 15:5 is valid and corresponding logical 16KB group should bypass this row.
15:5	WO	000h	Core	Row Number for Error0 (RNUMERR0): Row Number for Error0: The physical row number where the parity error has been detected. The number of rows vary between 4K vs 8K/16K subbanks which requires 10bits vs 11bits respectively. This field contains the row# with the error
4:1	RO	0000b	Core	Reserved (RSVD):
0	WO	0b	Core	Valid Error 0 (VLDERR0): Valid Error:



Bit	Access	Default Value	RST/PWR	Description
				The error located in field 15:5 is valid and corresponding logical 16KB group should bypass this row.

L3B2REG16 - L3 bank2 reg6 log error slice 1

B/D/F/Type: 0/0/0/SARBunit_Confi
g

Address Offset: B2C8-B2CBh

Default Value: 00000000h

Access: WO; RO;

Size: 32 bits

The ERROR LOG registers of L3 will maintain the bad row information for each of the 16KB subbank groups. The LOG will be programmed by driver before any workloads are submitted.

The contents of the LOG register will be context Save&Restored by h/w around rc6 events.

Bit	Access	Default Value	RST/PWR	Description
31:21	WO	000h	Core	Row Number for Error1 (RNUMERR1): Row Number for Error1: The physical row number where the parity error has been detected. The number of rows vary between 4K vs 8K/16K subbanks which requires 10bits vs 11bits respectively. This field contains the row# with the error
20:17	RO	0000b	Core	Reserved (RSVD):
16	WO	0b	Core	Valid Error 1 (VLDERR1): Valid Error: The error located in field 15:5 is valid and corresponding logical 16KB group should bypass this row.
15:5	WO	000h	Core	Row Number for Error0 (RNUMERR0): Row Number for Error0: The physical row number where the parity error has been detected. The number of rows vary between 4K vs 8K/16K subbanks which requires 10bits vs 11bits respectively. This field contains the row# with the error



Bit	Access	Default Value	RST/PWR	Description
4:1	RO	0000b	Core	Reserved (RSVD):
0	WO	0b	Core	Valid Error 0 (VLDERR0): Valid Error: The error located in field 15:5 is valid and corresponding logical 16KB group should bypass this row.

L3B2REG17 - L3 bank2 reg7 log error slice 1

B/D/F/Type: 0/0/0/SARBunit_Confi
g

Address Offset: B2CC-B2CFh

Default Value: 00000000h

Access: WO; RO;

Size: 32 bits

The ERROR LOG registers of L3 will maintain the bad row information for each of the 16KB subbank groups. The LOG will be programmed by driver before any workloads are submitted.

The contents of the LOG register will be context Save&Restored by h/w around rc6 events.

Bit	Access	Default Value	RST/PWR	Description
31:21	WO	000h	Core	Row Number for Error1 (RNUMERR1): Row Number for Error1: The physical row number where the parity error has been detected. The number of rows vary between 4K vs 8K/16K subbanks which requires 10bits vs 11bits respectively. This field contains the row# with the error
20:17	RO	0000b	Core	Reserved (RSVD):
16	WO	0b	Core	Valid Error 1 (VLDERR1): Valid Error: The error located in field 15:5 is valid and corresponding logical 16KB group should bypass this row.
15:5	WO	000h	Core	Row Number for Error0 (RNUMERR0):



Bit	Access	Default Value	RST/PWR	Description
				<p>Row Number for Error0:</p> <p>The physical row number where the parity error has been detected. The number of rows vary between 4K vs 8K/16K subbanks which requires 10bits vs 11bits respectively.</p> <p>This field contains the row# with the error</p>
4:1	RO	0000b	Core	Reserved (RSVD):
0	WO	0b	Core	<p>Valid Error 0 (VLDERR0):</p> <p>Valid Error:</p> <p>The error located in field 15:5 is valid and corresponding logical 16KB group should bypass this row.</p>

L3B3REG10 - L3 bank3 reg0 log error slice 1

B/D/F/Type: 0/0/0/SARBunit_Confi
g

Address Offset: B2D0-B2D3h

Default Value: 00000000h

Access: WO; RO;

Size: 32 bits

The ERROR LOG registers of L3 will maintain the bad row information for each of the 16KB subbank groups. The LOG will be programmed by driver before any workloads are submitted.

The contents of the LOG register will be context Save&Restored by h/w around rc6 events.

Bit	Access	Default Value	RST/PWR	Description
31:21	WO	000h	Core	<p>Row Number for Error1 (RNUMERR1):</p> <p>Row Number for Error1:</p> <p>The physical row number where the parity error has been detected. The number of rows vary between 4K vs 8K/16K subbanks which requires 10bits vs 11bits respectively.</p> <p>This field contains the row# with the error</p>
20:17	RO	0000b	Core	Reserved (RSVD):
16	WO	0b	Core	Valid Error 1 (VLDERR1):



Bit	Access	Default Value	RST/PWR	Description
				Valid Error: The error located in field 15:5 is valid and corresponding logical 16KB group should bypass this row.
15:5	WO	000h	Core	Row Number for Error0 (RNUMERR0): Row Number for Error0: The physical row number where the parity error has been detected. The number of rows vary between 4K vs 8K/16K subbanks which requires 10bits vs 11bits respectively. This field contains the row# with the error
4:1	RO	0000b	Core	Reserved (RSVD):
0	WO	0b	Core	Valid Error 0 (VLDERR0): Valid Error: The error located in field 15:5 is valid and corresponding logical 16KB group should bypass this row.

L3B3REG11 - L3 bank3 reg1 log error slice 1

B/D/F/Type: 0/0/0/SARBunit_Config

Address Offset: B2D4-B2D7h

Default Value: 00000000h

Access: WO; RO;

Size: 32 bits

The ERROR LOG registers of L3 will maintain the bad row information for each of the 16KB subbank groups. The LOG will be programmed by driver before any workloads are submitted.

The contents of the LOG register will be context Save&Restored by h/w around rc6 events.

Bit	Access	Default Value	RST/PWR	Description
31:21	WO	000h	Core	Row Number for Error1 (RNUMERR1): Row Number for Error1: The physical row number where the parity error has been detected. The number of rows vary between 4K vs 8K/16K subbanks which requires 10bits vs 11bits respectively.



Bit	Access	Default Value	RST/PWR	Description
				This field contains the row# with the error
20:17	RO	0000b	Core	Reserved (RSVD):
16	WO	0b	Core	Valid Error 1 (VLDERR1): Valid Error: The error located in field 15:5 is valid and corresponding logical 16KB group should bypass this row.
15:5	WO	000h	Core	Row Number for Error0 (RNUMERR0): Row Number for Error0: The physical row number where the parity error has been detected. The number of rows vary between 4K vs 8K/16K subbanks which requires 10bits vs 11bits respectively. This field contains the row# with the error
4:1	RO	0000b	Core	Reserved (RSVD):
0	WO	0b	Core	Valid Error 0 (VLDERR0): Valid Error: The error located in field 15:5 is valid and corresponding logical 16KB group should bypass this row.



L3B3REG12 - L3 bank3 reg2 log error slice 1

B/D/F/Type: 0/0/0/SARBunit_Confi
g
Address Offset: B2D8-B2DBh
Default Value: 00000000h
Access: WO; RO;
Size: 32 bits

The ERROR LOG registers of L3 will maintain the bad row information for each of the 16KB subbank groups. The LOG will be programmed by driver before any workloads are submitted.

The contents of the LOG register will be context Save&Restored by h/w around rc6 events.

Bit	Access	Default Value	RST/PWR	Description
31:21	WO	000h	Core	Row Number for Error1 (RNUMERR1): Row Number for Error1: The physical row number where the parity error has been detected. The number of rows vary between 4K vs 8K/16K subbanks which requires 10bits vs 11bits respectively. This field contains the row# with the error
20:17	RO	0000b	Core	Reserved (RSVD):
16	WO	0b	Core	Valid Error 1 (VLDERR1): Valid Error: The error located in field 15:5 is valid and corresponding logical 16KB group should bypass this row.
15:5	WO	000h	Core	Row Number for Error0 (RNUMERR0): Row Number for Error0: The physical row number where the parity error has been detected. The number of rows vary between 4K vs 8K/16K subbanks which requires 10bits vs 11bits respectively. This field contains the row# with the error
4:1	RO	0000b	Core	Reserved (RSVD):
0	WO	0b	Core	Valid Error 0 (VLDERR0): Valid Error:



Bit	Access	Default Value	RST/PWR	Description
				The error located in field 15:5 is valid and corresponding logical 16KB group should bypass this row.

L3B3REG13 - L3 bank3 reg3 log error slice 1

B/D/F/Type: 0/0/0/SARBunit_Confi
g

Address Offset: B2DC-B2DFh

Default Value: 00000000h

Access: WO; RO;

Size: 32 bits

The ERROR LOG registers of L3 will maintain the bad row information for each of the 16KB subbank groups. The LOG will be programmed by driver before any workloads are submitted.

The contents of the LOG register will be context Save&Restored by h/w around rc6 events.

Bit	Access	Default Value	RST/PWR	Description
31:21	WO	000h	Core	Row Number for Error1 (RNUMERR1): Row Number for Error1: The physical row number where the parity error has been detected. The number of rows vary between 4K vs 8K/16K subbanks which requires 10bits vs 11bits respectively. This field contains the row# with the error
20:17	RO	0000b	Core	Reserved (RSVD):
16	WO	0b	Core	Valid Error 1 (VLDERR1): Valid Error: The error located in field 15:5 is valid and corresponding logical 16KB group should bypass this row.
15:5	WO	000h	Core	Row Number for Error0 (RNUMERR0): Row Number for Error0: The physical row number where the parity error has been detected. The number of rows vary between 4K vs 8K/16K subbanks which requires 10bits vs 11bits respectively. This field contains the row# with the error



Bit	Access	Default Value	RST/PWR	Description
4:1	RO	0000b	Core	Reserved (RSVD):
0	WO	0b	Core	Valid Error 0 (VLDERR0): Valid Error: The error located in field 15:5 is valid and corresponding logical 16KB group should bypass this row.

L3B3REG14 - L3 bank3 reg4 log error slice 1

B/D/F/Type: 0/0/0/SARBunit_Confi
g

Address Offset: B2E0-B2E3h

Default Value: 00000000h

Access: WO; RO;

Size: 32 bits

The ERROR LOG registers of L3 will maintain the bad row information for each of the 16KB subbank groups. The LOG will be programmed by driver before any workloads are submitted.

The contents of the LOG register will be context Save&Restored by h/w around rc6 events.

Bit	Access	Default Value	RST/PWR	Description
31:21	WO	000h	Core	Row Number for Error1 (RNUMERR1): Row Number for Error1: The physical row number where the parity error has been detected. The number of rows vary between 4K vs 8K/16K subbanks which requires 10bits vs 11bits respectively. This field contains the row# with the error
20:17	RO	0000b	Core	Reserved (RSVD):
16	WO	0b	Core	Valid Error 1 (VLDERR1): Valid Error: The error located in field 15:5 is valid and corresponding logical 16KB group should bypass this row.
15:5	WO	000h	Core	Row Number for Error0 (RNUMERR0):



Bit	Access	Default Value	RST/PWR	Description
				<p>Row Number for Error0:</p> <p>The physical row number where the parity error has been detected. The number of rows vary between 4K vs 8K/16K subbanks which requires 10bits vs 11bits respectively.</p> <p>This field contains the row# with the error</p>
4:1	RO	0000b	Core	Reserved (RSVD):
0	WO	0b	Core	<p>Valid Error 0 (VLDERR0):</p> <p>Valid Error:</p> <p>The error located in field 15:5 is valid and corresponding logical 16KB group should bypass this row.</p>

L3B3REG15 - L3 bank3 reg5 log error slice 1

B/D/F/Type: 0/0/0/SARBunit_Confi
g

Address Offset: B2E4-B2E7h

Default Value: 00000000h

Access: WO; RO;

Size: 32 bits

The ERROR LOG registers of L3 will maintain the bad row information for each of the 16KB subbank groups. The LOG will be programmed by driver before any workloads are submitted.

The contents of the LOG register will be context Save&Restored by h/w around rc6 events.

Bit	Access	Default Value	RST/PWR	Description
31:21	WO	000h	Core	<p>Row Number for Error1 (RNUMERR1):</p> <p>Row Number for Error1:</p> <p>The physical row number where the parity error has been detected. The number of rows vary between 4K vs 8K/16K subbanks which requires 10bits vs 11bits respectively.</p> <p>This field contains the row# with the error</p>
20:17	RO	0000b	Core	Reserved (RSVD):
16	WO	0b	Core	Valid Error 1 (VLDERR1):



Bit	Access	Default Value	RST/PWR	Description
				Valid Error: The error located in field 15:5 is valid and corresponding logical 16KB group should bypass this row.
15:5	WO	000h	Core	Row Number for Error0 (RNUMERR0): Row Number for Error0: The physical row number where the parity error has been detected. The number of rows vary between 4K vs 8K/16K subbanks which requires 10bits vs 11bits respectively. This field contains the row# with the error
4:1	RO	0000b	Core	Reserved (RSVD):
0	WO	0b	Core	Valid Error 0 (VLDERR0): Valid Error: The error located in field 15:5 is valid and corresponding logical 16KB group should bypass this row.

L3B3REG16 - L3 bank3 reg6 log error slice 1

B/D/F/Type: 0/0/0/SARBunit_Config

Address Offset: B2E8-B2EBh

Default Value: 00000000h

Access: RO; WO;

Size: 32 bits

The ERROR LOG registers of L3 will maintain the bad row information for each of the 16KB subbank groups. The LOG will be programmed by driver before any workloads are submitted.

The contents of the LOG register will be context Save&Restored by h/w around rc6 events.

Bit	Access	Default Value	RST/PWR	Description
31:21	WO	000h	Core	Row Number for Error1 (RNUMERR1): Row Number for Error1: The physical row number where the parity error has been detected. The number of rows vary between 4K vs 8K/16K subbanks which requires 10bits vs 11bits respectively.



Bit	Access	Default Value	RST/PWR	Description
				This field contains the row# with the error
20:17	RO	0000b	Core	Reserved (RSVD):
16	WO	0b	Core	Valid Error 1 (VLDERR1): Valid Error: The error located in field 15:5 is valid and corresponding logical 16KB group should bypass this row.
15:5	WO	000h	Core	Row Number for Error0 (RNUMERR0): Row Number for Error0: The physical row number where the parity error has been detected. The number of rows vary between 4K vs 8K/16K subbanks which requires 10bits vs 11bits respectively. This field contains the row# with the error
4:1	RO	0000b	Core	Reserved (RSVD):
0	WO	0b	Core	Valid Error 0 (VLDERR0): Valid Error: The error located in field 15:5 is valid and corresponding logical 16KB group should bypass this row.



L3B3REG17 - L3 bank3 reg7 log error slice 1

B/D/F/Type: 0/0/0/SARBunit_Confi
g
Address Offset: B2EC-B2EFh
Default Value: 00000000h
Access: RO; WO;
Size: 32 bits

The ERROR LOG registers of L3 will maintain the bad row information for each of the 16KB subbank groups. The LOG will be programmed by driver before any workloads are submitted.

The contents of the LOG register will be context Save&Restored by h/w around rc6 events.

Bit	Access	Default Value	RST/PWR	Description
31:21	WO	000h	Core	Row Number for Error1 (RNUMERR1): Row Number for Error1: The physical row number where the parity error has been detected. The number of rows vary between 4K vs 8K/16K subbanks which requires 10bits vs 11bits respectively. This field contains the row# with the error
20:17	RO	0000b	Core	Reserved (RSVD):
16	WO	0b	Core	Valid Error 1 (VLDERR1): Valid Error: The error located in field 15:5 is valid and corresponding logical 16KB group should bypass this row.
15:5	WO	000h	Core	Row Number for Error0 (RNUMERR0): Row Number for Error0: The physical row number where the parity error has been detected. The number of rows vary between 4K vs 8K/16K subbanks which requires 10bits vs 11bits respectively. This field contains the row# with the error
4:1	RO	0000b	Core	Reserved (RSVD):
0	WO	0b	Core	Valid Error 0 (VLDERR0): Valid Error:



Bit	Access	Default Value	RST/PWR	Description
				The error located in field 15:5 is valid and corresponding logical 16KB group should bypass this row.

LPFCREG13 - Error Reporting Reg Slice 1

B/D/F/Type: 0/0/0/SARBunit_Confi

g

Address Offset: B2F8-B2FBh

Default Value: 00000000h

Access: RO; RWC;

Size: 32 bits

This reg is not ctx saved/restored.

Bit	Access	Default Value	RST/PWR	Description
31:5	RO	0000000h	Core	Reserved (RSVD):
4	RWC	0b	Core	<p>First Content Buffer Ready 1 (FRSNTBFR1):</p> <p>First Content Buffer Ready: This bits gets set by the h/w when the buffer is completely filled up and cleared by the driver when the contents of this buffer is copied out of memory.</p> <p>Will be set by lpfc_sarbcf_buffer0_ready (pulse) sarbcf_lpfc_buffer0_ready (static signal to lpfc)</p>
3	RWC	0b	Core	<p>Second Content Buffer Ready slice 1 (SCNBFR1):</p> <p>Second Content Buffer Ready: This bits gets set by the h/w when the buffer is completely filled up and cleared by the driver when the contents of this buffer is copied out of memory.</p> <p>Will be set by lpfc_sarbcf_buffer1_ready(pulse) sarbcf_lpfc_buffer1_ready (static signal to lpfc)</p>
2	RWC	0b	Core	<p>Write Expired Error slice 1 (WEERR1):</p> <p>Write Expired Error: If DMA controller could not get a chance to push the write of 64Bytes to GAPL3 and data get clobbered with the new expiration of the save timer, this error bit will be set to indicate something went wrong.</p> <p>Signal - lpfc_sarbcf_wrexp_error</p>



Bit	Access	Default Value	RST/PWR	Description
1	RWC	0b	Core	Buffer full Error Slice 1 (BFFLERR1): Set by lpfc_sarbcf_error_buffer_full When both buffers are full lpfc will set this bit or if only 1 buffer is enabled then lpfc will set this bit when the buffer is full.
0	RO	0b	Core	Reserved (RSVD):

LPCNTR8S1 - LPFC counter reg08 slice 1

B/D/F/Type: 0/0/0/SARBunit_Confi
 g
Address Offset: B268-B26Bh
Default Value: 00000000h
Access: RO;
Size: 32 bits

Bit	Access	Default Value	RST/PWR	Description
31:0	RO	00000000h	Core	LPFC Counter 8 slice 1 (LPFCNT18): Counter8



Media GPGPU Pipeline

GPGPU Overview

Programming the GPGPU Pipeline

1. In MEDIA_VFE_STATE choose whether to set DW2.6 Bypass Gateway Control. Usually this will be set, allowing the gateway to be used without OpenGateway/CloseGateway.
2. Set up interface descriptor with # of threads in barrier. The barrier id is not specified here because can Gen7 automatically assigns barriers to thread groups when they are free. The amount of CURBE data to deliver per thread dispatch is set in the interface descriptor.
3. Set up CURBE with thread ids and common data for all thread dispatches in the thread group.
4. Set up a GPGPU_WALKER command or a set of GPGPU_OBJECT commands with the thread group ids to dispatch the threads. The CURBE data is sent in sections for each thread dispatch in the thread group; a new thread group starts sending the CURBE data from the beginning of the buffer.

Note: Gen7 can either have the barriers and SLM automatically managed by hardware or specified by software. Mixing software managed and hardware managed in the same set of threads is allowed, but may cause stalls if there is an allocation conflict.

Note: When using GPGPU_OBJECT, finish dispatching a thread group before starting a different one.

The kernel should handle the barriers as follows:

The BarrierMsg message contains the barrier id and a way to reprogram the barrier count. The barrier count reprogram is not normally used for GPGPU workloads. When all threads in the group have reached the barrier, the gateway returns a notification bit 0.

The kernel must wait for the barrier to finish with a WAIT NO.

GPGPU Thread Limits

GPGPU requires 1024 SIMD channels to be available for a maximum size thread group. In a HSW/GT2 system with 10 EUs per subslice, each with 7 hardware threads, this means that a maximum size thread group will fit in a subslice if SIMD16 instructions are used, but not if SIMD8 are used. These limits can be circumvented for thread groups which do not need access to a barrier or SLM, in which case the thread group can cross sub-slices.

The Configurations section should be referenced to determine what SIMD is required to fit in the subslice of the targeted configuration.



GPGPU Commands

This section contains various commands for GPGPU, including a number of them shared with media mode.

MEDIA_VFE_STATE with varying definitions for different generations and projects:

MEDIA_VFE_STATE

MEDIA_CURBE_LOAD

MEDIA_INTERFACE_DESCRIPTOR_LOAD

Interface Descriptor Data payload as pointed to by the Interface Descriptor Data Start Address, with varying definitions for different generations and projects:

INTERFACE_DESCRIPTOR_DATA

Project:
The MEDIA_STATE_FLUSH command is updated to specify all the resources required for the next thread group via an interface descriptor – if the resources are not available the group cannot start.

MEDIA_STATE_FLUSH

GPGPU_WALKER

GPGPU_OBJECT



GPGPU Indirect Thread Dispatch

Indirect thread dispatch allows one thread group to control the group size of a following thread group.

This is the sequence of commands in the ring buffer:

GPGPU_OBJECT/WALKER	// Either a set of objects or a walker to dispatch a thread group which will write the next group's properties to memory.
MI_FLUSH	// Make sure the thread group has finished executing.
MEDIA_CURBE_LOAD	// Load the thread ids for new group.
MI_LOAD_REGISTER_MEMORY	// Load the indirect MMIO GPGPU registers from the mem written by the previous group.
GPGPU_WALKER (indirect)	// A walker with the indirect bit set.

The first thread group writes this data to memory:

1. The thread ids delivered in the CURBE - written where the following MEDIA_CURBE_LOAD will read them.
2. The GPGPU_WALKER parameters are written to memory where the MI_LOAD_REGISTER_MEMORY will read them.
 - a. GPGPU_DISPATCHDIMX - the X dimension of the number of thread groups to dispatch in:

DWord	Project
4	

- b. GPGPU_DISPATCHDIMY - the Y dimension of the number of thread groups to dispatch in:

DWord	Project
6	

- c. GPGPU_DISPATCHDIMZ - the Z dimension of the number of thread groups to dispatch in:

DWord	Project
8	

See vol1c Memory Interface and Command Stream for the MMIO register addresses and formats.

Project:	
Security:	
WA.Workaround	
<p>The indirect registers are not supposed to be set to 0, but sometimes the kernel computing the value wants no work done and sets them to 0. This does not work correctly, so a workaround in the command stream is needed:</p> <pre> GPGPU_WALKER // The thread group which writes the indirect values to memory locations MI_CONDITIONAL_BATCH_BUFFER_END DIMX StartX // End batch buffer if X dim in memory = StartX in DWord per table immediately below MI_CONDITIONAL_BATCH_BUFFER_END DIMY 0 StartY // End batch buffer if Y dim in memory = StartY in DWord per table immediately below MI_CONDITIONAL_BATCH_BUFFER_END DIMZ 0 StartZ // End batch buffer if Z dim in memory </pre>	



Project:		
Security:		WA.Workaround
<pre>= StartZ in DWord per table immediately below MI_LOAD_REGISTER_MEM GPGPU_DISPATCHDIMX DIMX // Normal load of register from memory MI_LOAD_REGISTER_MEM GPGPU_DISPATCHDIMY DIMY MI_LOAD_REGISTER_MEM GPGPU_DISPATCHDIMZ DIMZ GPGPU_WALKER // The thread groups which depend on the indirect dimensions</pre>		
Project	DWord Information	
	StartX in DW3, StartY in DW5, StartZ in DW7	



GPGPU Context Switch

The GPGPU pipeline supports interruption of GPGPU workloads on thread group boundaries. This is needed for general purpose GPGPUs that are so large that there is a risk of the display becoming non-responsive if the work cannot be interrupted for other jobs.

A workload is interrupted with the MI_ARB_CHECK command with the UHPTR register. The MI_ARB_CHECK command is placed throughout the command buffer. The driver updates the UHPTR register when a new context is needed; MI_ARB_CHECK checks for this and reprograms the head and tail pointers to the new batch of commands. The driver waits for the preemption to occur without going into RS2.

The GPGPU needs to modify this to allow a GPGPU_WALKER command to be interrupted. This is done by following each GPGPU_WALKER command with a MEDIA_STATE_FLUSH. This causes the CS to stop fetching commands until either the command completes or until the UHPTR valid bit is set.

GPGPU workloads can be dispatched with either GPGPU_OBJECT commands or GPGPU_WALKER commands. In the case of GPGPU_OBJECT, the MEDIA_STATE_FLUSH/ MI_ARB_CHECK pair must be placed in the batch buffer at thread group boundaries, since preemption cannot occur with a thread group partially dispatched. GPGPU_WALKER commands can dispatch multiple thread groups, in this case the MEDIA_STATE_FLUSH/ MI_ARB_CHECK follows each GPGPU_WALKER and the hardware takes care of noticing the UHPTR update and stopping at the next thread group boundary.

The commands in the batch buffer will look something like this:

Command Ring	Comments
MI_SET_CONTEXT	Go to GPGPU context
MI_BATCH_BUFFER_START	If new context, set address to top of batch. Otherwise, address needs to be set to the command preempted (given in the HWSP). The GP GPGPU bit must be set.

Command Batch	Comments
GPGPU_OBJECT	
GPGPU_OBJECT	
...	(more threads forming a complete thread group)
MEDIA_STATE_FLUSH	Check for preemption at thread group boundary. "Preemption" defined by the UHPTR valid bit set.
MI_ARB_CHECK	Move the head only if UHPTR valid bit is set.
...	
GPGPU_WALKER	
MEDIA_STATE_FLUSH	Check for preemption at thread group boundary internal to GPGPU_WALKER command. "Preemption" defined by the UHPTR valid bit set.
MI_ARB_CHECK	Move the head only if UHPTR valid bit is set.



Command Batch	Comments
...	
MI_BATCH_BUFFER_END	GPCS batch workload bit is cleared.

The context saved will consist of the state commands for VFE and a modified GPGPU_WALKER command with a new starting thread group id. On context restore, the commands are executed to start the GPGPU_WALKER where it left off before continuing with the rest of the command buffer.

An example software model for starting a preemption goes like this:

1. The UHPTR is reprogrammed to point to the current tail of the ring buffer.
2. Insert new commands:
 - a. LRI to UHPTR to clear valid.
 - b. Store Register to mem the preempted batch offset.
 - c. Store Register to mem the preempted ring offset.
 - d. Pipe_control notification.
 - e. An MI_SET_CONTEXT to the new context is put into the ring.
3. Insert commands for new context. i.e. batch buffers.
4. Update Tail Pointer.

Note: 2-3 items above could happen during execution of a thread group so the HW may see the tail pointer updated before preemption starts.

Note: The driver needs to turn off RC6 during items 1 and 4.

GPGPU_CSR_BASE_ADDRESS



GPGPU Context Switch

The last GPGPU_WALKER or GPGPU_OBJECT in a command buffer should be followed by a MEDIA_STATE_FLUSH with the "Flush to GO" bit set to ensure that the last group can be preempted.

The Interface Descriptor offset is limited to the range 0 to 31 when context switch is used.

Project:	HSW:GT1
For the GT1 SKU only, preemption can be used if the workload is split into chunks that will fit into the machine at one time. So each chunk must have 70 threads or less, 16 barriers or less, and 64k of SLM or less. A PIPE_CONTROL is used between each chunk to flush the pipe. Alternatively, preemption can be turned off for workloads that use SLM or barriers.	



Media GPGPU Payload Limitations

There are 3 types of payload that the media/GPGPU instructions can have, but not all of them are allowed. The following table lists the legal combinations:

Workload	Commands	Data Stored	Project
GPGPU	GPGPU_WALKER	CURBE	
	GPGPU_OBJECT	CURBE	
Media(Legacy)	Media_Object	CURBE	
	Media_Object	INDIRECT	
	Media_Object	INLINE	
	Media_Object	CURBE+INLINE	
	Media_Object	CURBE+INDIRECT	
	Media_Object	INLINE+INDIRECT	
	Media_Object	CURBE+ INLINE+INDIRECT	
	Media_Object_Walker	CURBE	
	Media_Object_Walker	INLINE	
	Media_Object_Walker	CURBE+INLINE	



Synchronization of the Media/GPGPU Pipeline

The Media/GPGPU Pipeline is synchronized in the same way as the 3D pipeline using the PIPE_CONTROL command.

See the PRM section on 3D pipe synchronization: [vol2a 3D Pipeline - Overview \[SNB+\] > 3D Pipeline > Synchronization of the 3D Pipeline.](#)



Mode of Operations

This section contains registers for GPGPU Object and GPGPU Command. It also covers GPGPU Mode.

GPGPU Thread R0 Header

The RO header of the Thread Dispatch Payload for the GPGPU thread:

DWord	Bits	Description	Project	Security
R0.7	31:0	Thread Group ID Z: This field identifies the Z component of the thread group that this thread belongs to.		
R0.6	31:0	Thread Group ID Y: This field identifies the Y component of the thread group that this thread belongs to.		
R0.5	31:10	Scratch Space Pointer. Specifies the 1K-byte aligned pointer to the scratch space. Format = GeneralStateOffset[31:10]		
	9	GPGPU Dispatch. Indicates that this dispatch is from the GPGPU pipe (see PIPELINE_SELECT command).		
	8	Reserved: MBZ		
	7:0	FTID. This ID is assigned by TS and is a unique identifier for the thread in comparison to other concurrent threads (of any thread group). It is used to free up resources used by the thread upon thread completion. Format = U8.		
R0.4	31:5	Binding Table Pointer. Specifies the 32-byte aligned pointer to the Binding Table. It is specified as an offset from the Surface State Base Address . Format = SurfaceStateOffset[31:5]		
	4	Reserved: MBZ		
	3:0	Indicates the stack memory size. Range = [0,11] indicating [1K bytes, 2M bytes]		
R0.3	31:5	Sampler State Pointer. Specifies the 32-byte aligned pointer to the sampler state		



DWord	Bits	Description	Project	Security
		table. Format = GeneralStateOffset[31:5]		
	4	Reserved: MBZ		
	3:0	Per Thread Scratch Space. Specifies the amount of scratch space, in 16-byte quantities, allowed to be used by this thread. The value specifies the power that two is raised to, to determine the amount of scratch space. Format = U4 Range = [0,10] indicating [2K bytes, 2M bytes] in powers of two.		
R0.2	31	Reserved: MBZ		
	30	Reserved: MBZ		
	29	Barrier Enable: This field indicates that a barrier has been allocated for this kernel.		
	28	SLM Enable: This field indicates that Shared Local Memory has been allocated for this kernel.		
	27:24	BarrierID: This field indicates the barrier that this kernel is associated with. Format: U4		
	14:10	Reserved: MBZ		
	9:4	Interface Descriptor Offset. This field specifies the offset from the interface descriptor base pointer to the interface descriptor which will be applied to this object. It is specified in units of interface descriptors. Format = U6		
	3:0	Reserved: MBZ		
R0.1	31:0	Thread Group ID X: This field identifies the X component of the thread group that this thread belongs to.		
R0.0	31:30	Reserved: MBZ		
	29:28	Reserved: MBZ		
	27:24	Shared Local Memory Index: Indicates the starting index for the shared local memory for the thread group. Each index points to the start of a 4K memory block,		



DWord	Bits	Description	Project	Security
		16 possibilities cover the entire 64K shared memory per half-slice. Format = U4		
	23:16	Reserved: MBZ		
	15:0	URB Handle: This is the URB handle indicating the URB space for use by the thread.		

Cross-thread CURBE if present is in R1 and above, followed by the X/Y/Z thread id values for each channel in the thread.

Project:	HSW
The GPGPU_OBJECT command is modified from the MEDIA_OBJECT command. It is no longer supported.	

GPGPU_OBJECT

GPGPU_WALKER

GPGPU Mode [Project: IVB+, VLVT]

The general purpose (GPGPU) mode allows the Gen7 architecture to be used by general purpose parallel APIs:

- GPGPU
- DX11 GPGPU

This is similar to the Generic mode with additional support for automatic generation of threads, Shared Local Memory, and Barriers.

Automatic Thread Generation

A single GPGPU job may require thousands or even millions of GPU_OBJECT commands. Rather than create them separately, it would be better to generate them algorithmically. To do this a GPGPU_WALKER command is created.

Rather than modifying the Media Walker, a simple Thread Group Walker is created instead:

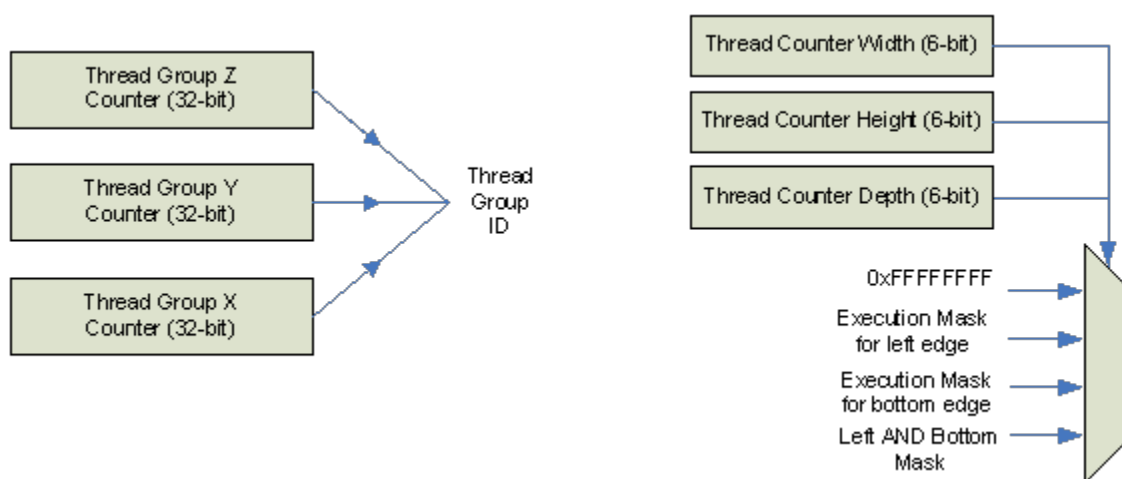

The X/Y/Z counters for the thread group will have an initial and maximum value. The thread group ID sent with each dispatch consists of these 3 numbers. These counters are 32 bits since the spec does not limit the size of the thread ID.

The 3 thread counters count the number of dispatches in a single thread group – up to 32 dispatches for SIMD32 or 64 dispatches for SIMD16/8. There are 3 of them in order to select the execution masks correctly – see section *Execution Mask* on execution masks. Each one is 6 bits to allow full flexibility of any dimension going to 64 while the rest do not increment.

A thread is generated each time one of the thread counters increment. When all the counters reach their maximum values, the thread group is done and the thread group counter can increment and start a new thread group. When the thread group X counter reaches its maximum it is reset to 0, and the Y counter is incremented.

The compiler determines how many SIMD channels are needed per thread group, and then decides how these are split among EU threads. The number of threads is programmed in the thread counter, and the SIMD mode (SIMD8/SIMD16/SIMD32) is specified in the GPGPU_WALKER command.

Project	Description
HSW	The maximum thread group size must fit into a single subslice and run in parallel, so the number of EU threads must be less than the number specified in Configurations for threads per subslice.

Thread Payload

The payload to each thread dispatched is:

1. A thread group id which identifies the group the set of threads belong to. This is in the form of a set of 3, 32-bit X/Y/Z values.
2. The set of X/Y/Z that form the thread ID for each channel. If Z is not used then only X/Y are needed.
3. The execution mask which indicates which channels are active.



Thread IDs form a 2D or 3D surface which has to be mapped into SIMD32, SIMD16 or SIMD8 dispatches. Rather than have the hardware force a particular mapping of thread IDs to channels, the mapping will be supplied by the compiler. The VFE will receive a simple count of the number of threads per thread group which will be used to count the number of dispatches. The thread IDs for all threads in a thread group are put in a constant buffer with the MEDIA_CURBE_LOAD command. A single set of thread IDs can be used repeatedly for all thread groups, since the thread IDs are the same for each thread group ID output by the GPGPU_WALKER.

The data required is up to the compiler, but here is an example set of payloads for a 2 Z x 2Y x 12 X and a SIMD16 dispatch. This thread group requires 3 dispatches:

3 2 1 0 11 10 9 8 7 6 5 4 3 2 1 0	Thead id X for dispatch 0
1 1 1 1 0 0 0 0 0 0 0 0 0 0 0	Thead id Y for dispatch 0
0 0 0 0 0 0 0 0 0 0 0 0 0 0 0	Thead id Z for dispatch 0
7 6 5 4 3 2 1 0 11 10 9 8 7 6 5 4	Thead id X for dispatch 1
0 0 0 0 0 0 0 0 1 1 1 1 1 1 1	Thead id Y for dispatch 1
1 1 1 1 1 1 1 1 0 0 0 0 0 0 0	Thead id Z for dispatch 1
11 10 9 8 7 6 5 4 3 2 1 0 11 10 9 8	Thead id X for dispatch 2
1 1 1 1 1 1 1 1 1 1 1 1 0 0 0	Thead id Y for dispatch 2
1 1 1 1 1 1 1 1 1 1 1 1 1 1 1	Thead id Z for dispatch 2

In this case the thread counter width would be programmed with a maximum value of 3 (since all the execution masks are all F, it doesn't matter how the thread counters are programmed as long as they count to 3 before finishing the thread group).

The first dispatch would tell the TS (who would tell the TD) that the payload starts at the beginning of the constant buffer and has a length of 3. The next dispatch would have a payload starting at constant_buffer_start + 3. The final dispatch payload starts at constant_buffer_start + 6. If there are more thread groups in the command they would get exactly the same payload – the only difference is the thread group ID.

Execution Masks

The number of channels required by the GPGPU job may not evenly fit into the number of SIMD channels. That can leave some channels idle. The execution mask is used to tell the hardware which channels are to be used.

A thread group is modeled as a 3D solid with each channel acting as one X/Y/Z point in the solid. This can take the form of a line with 1024 channels with X from 0 to 1023 and constant Y/Z, a square with X=0 to 32 and Y=0 to 32, or a cube with X=0 to 9, Y=0 to 9, Z=0 to 9. Software needs to determine how these shapes are mapped onto the 32 SIMD32 channels per dispatch (or 16 SIMD16, etc). The mapping per thread is assumed to be a 2D square of channels such as 8x4, 16x2, 32x1. Below is a diagram of a 22x6 thread group that is mapped onto a set of 8x4 SIMD32 channels:



8x4	8x4	8x4	
8x4	8x4	8x4	
8x4	8x4	8x4	

Note that the dispatches to the top and left have execution masks of all-F, while all the right edge dispatches have the same execution mask; likewise all the bottom edge dispatches have the same execution mask. The bottom right is the logical-AND of the right and bottom edge dispatches.

A 32-bit right and bottom mask is sent with the GPGPU_WALKER command, and the thread width, height and depth counters are used to determine when they are used (width, height and depth are used instead of X/Y/Z, since it is not required that width = X – width and height are the two variables that are changing in a single SIMD dispatch even if they are Y and Z).

For each dispatch the width counter is incremented until it reaches the maximum – the dispatch with width=max will use the right execution mask. The height counter is then incremented and process repeated. If at any time the height counter = max then the execution mask is the bottom execution mask. When the height and width counters are both max then the dispatch will be the AND of the right and bottom and the depth counter will increment.

The same 2Z x 2Y x 12X thread group described above dispatched as SIMD32 with each dispatch delivering a 16X x 2Y shape would require 2 dispatches with empty bits in the right execution mask and all F in the bottom.

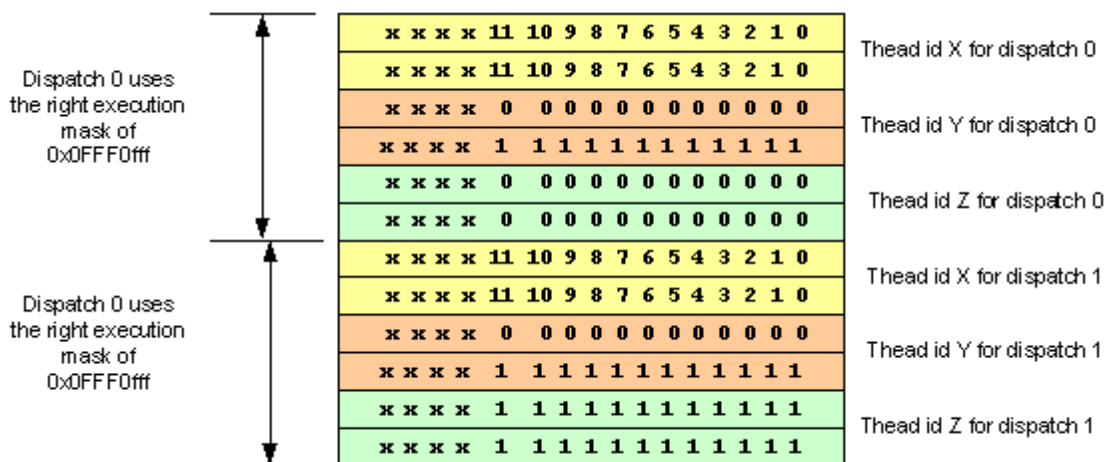

The width and height counter would have a maximum of 1, and the depth counter would have a maximum of 2. The two dispatches would use the AND of the two masks, but since the bottom mask is F it would be the same as just the right mask.

The execution masks can also be used when the software wants to pack the channels rather than lay them out in a regular pattern:



3 2 1 0 11 10 9 8 7 6 5 4 3 2 1 0	Thread id X for dispatch 0
7 6 5 4 3 2 1 0 11 10 9 8 7 6 5 4	Thread id Y for dispatch 0
1 1 1 1 0 0 0 0 0 0 0 0 0 0 0	Thread id Z for dispatch 0
0 0 0 0 0 0 0 0 1 1 1 1 1 1 1	Thread id X for dispatch 1
0 0 0 0 0 0 0 0 0 0 0 0 0 0 0	Thread id Y for dispatch 1
1 1 1 1 1 1 1 1 0 0 0 0 0 0 0	Thread id Z for dispatch 1
11 10 9 8 7 6 5 4 3 2 1 0 11 10 9 8	
1 1 1 1 1 1 1 1 1 1 1 1 0 0 0 0	
1 1 1 1 1 1 1 1 1 1 1 1 1 1 1 1	

In this case the width counter can have a maximum of 2, and the height and depth counters with a maximum of 1. The first dispatch will use the bottom mask only (all-F) and the second will use the right AND bottom mask to remove the channels that are not used.

Payload Storage

The MEDIA_CURBE_LOAD constant data is stored in the URB by CS and read out by TDL when the dispatch occurs. Data is sent in two sections – the cross-thread constant data (if present) is read out first by TDL from the CURBE handle in the transparent header, and the thread IDs are read out second via an inline handle. If cross-thread CURBE data is not present, then only the inline handle is used for the thread IDs. The inline payload with the execution counts is sent to VFE from CS. The execution counts are stored internal to VFE.

The thread id handle length is specified in the transparent header as the Push Constant Length for Buffer0. The cross-thread constant data handle length is specified in the transparent header as the Handle Length for Input Handles in DWord 0, bits 18:12.

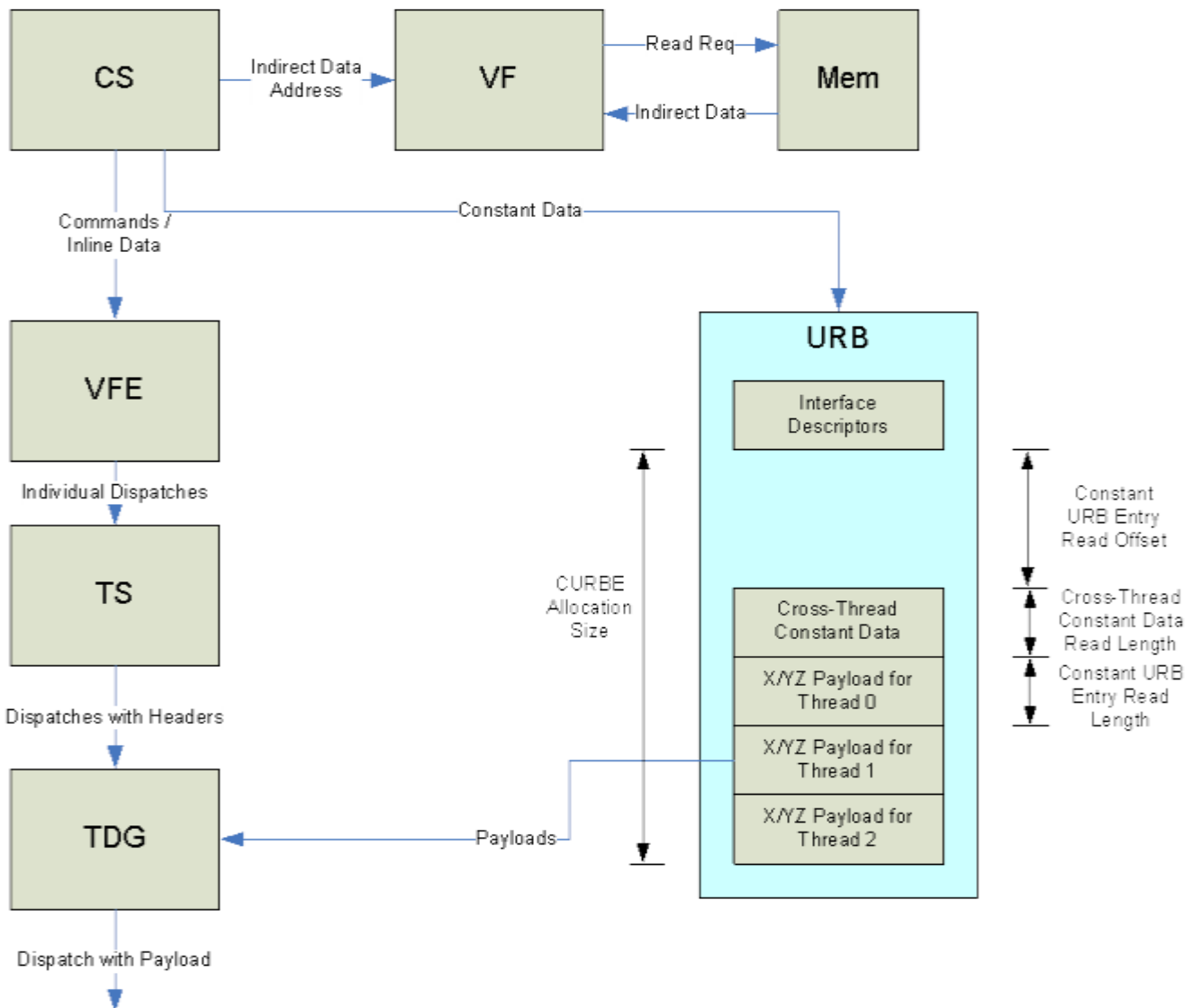

Only 32 threads are allowed for SIMD32 to match the 1024 thread limit, requiring 32 execution count bytes, or 8 DW payload. SIMD16 and SIMD8 allow the full 64 thread per half-slice, and so require as much as 16 DWords.

The X/Y/Z payload size per dispatch is specified in the command, but a maximum size is 3 16-bit numbers per 1024 SIMD channels, or 6 kbytes.



URB Management

The VFE manages the URB in GPGPU and generic/media modes.

Project	Description
HSW	<p>The first 64 URB entries are reserved for the interface description, and CURBE data is placed after the IDs. URB handles are needed for indirect data and parent/child communication; when the VFE starts up it creates up to 128 handles by partitioning the remaining URB space into evenly spaced addresses and saving the resulting handles in a FIFO. The handles can then be treated just like ones created by the URBM - send to TD on dispatch and recovered on the handle return bus.</p> <p>MEDIA_VFE_STATE specifies the amount of CURBE space, the URB handle size and the number of URB handles. The driver must ensure that: $((\text{URB_handle_size} * \text{URB_num_handle}) - \text{CURBE} - 64) \leq \text{URB_allocation_in_L3}$.</p>



Thread Group Tracking

The TSG needs to keep track of the threads outstanding in a group to know when the thread group barrier and Shared Local Memory can be reclaimed. This can be done by keeping a counter per active thread group (up to 16 per half-slice) which increments when a new thread is sent out and decremented when the thread retires. The assigned barrier ID (with half-slice bit) is unique per thread group and much smaller than the thread group ID and so will be used to keep track of the thread group instead.

Since TSL sends the thread retirement via the Message Channel rather than the thread retirement bus, the barrier ID used to identify the thread group can be sent at the same time. A CAM will then match the ID with the counter to decrement.

There is a potential corner case of a thread group without barriers being partly dispatched, then retiring before the rest of the thread group is sent. This should be OK, since the lack of barriers means that there are no dependencies between threads.



Shared Local Memory Allocation

The Shared Local Memory is a 64k block per half-slice in the L3 that must be shared between all thread groups on that half-slice. A new memory manager similar to the Scratch Space memory manager is used to allocate this space.

We are only dispatching threads from a single Interface Descriptor at a time. If a new Interface Descriptor is requested the pipe is drained and all shared memory recovered before starting to allocate new shared memory. This means that only a single size of shared memory needs to be supported at once.

For simplicity, only power-of-2 sizes from 4k to 64k are allowed. The thread request will specify how much is needed. The first thread of a Thread Group is marked as requiring a new shared local memory – if not the old Shared Local Memory offset is sent with the dispatch.

A simple set of 16-bits is used to allocate 4k shared memory, with fewer bits used for larger sizes. A priority encoder finds the first unused bit and the offset remembered as being associated with a particular barrier id. The barrier id is then used to track the thread group.

When the Thread Group Tracking indicates that a thread group is completely retired, that section of shared local memory can be reclaimed.



Software Managed Shared Local Memory

Software can optionally manage shared local memory. In this case, each thread command or thread group command will have the shared memory offset included – each command in a thread group must have the same offset, of course. If the offset requested is still being used then the command is stalled until the thread group using that offset is done.

Hardware will track the usage of this section of shared memory as before, recording the offset as being used and recording it as being available after the thread group is done.



Automatic Barrier Management

Project	Description
	Since we have an automatic shared memory allocation it makes sense to make barrier management automatic too. Instead of the barrier id in the Interface Descriptor, there is now a thread count per thread group.
	If a new thread group id comes in without a barrier allocated (checked with a CAM match across 16 barriers), the TSG picks a unused barrier and sends this count in a message to GWunit. It then needs to wait for an accept message back from GW before sending the dispatch to ensure that a barrier message doesn't arrive at the GW before the barrier is programmed. The barrier ID picked is sent with every dispatch from this thread group.
	When the thread group tracker determines that a thread group has finished, the barrier becomes available to new thread groups.



Local Memory/Scratch Space

The Local Memory (not to be confused with Shared Local Memory, which is shared by all thread in a thread group) is allocated per thread dispatched to the EU.

The Scratch Space manager is used to provide between 1k and 2M bytes memory per thread.

The Scratch Space Manager automatically separates the scratch space for each subslice by $128 * \text{Scratch_space_size}$. Memory usage can be optimized for large scratch spaces by adding an adjustment to the kernel to reduce this separate to the number of threads per subslice.

New Scratch Space Pointer = Old Scratch Space Pointer - FFTID[8:7] (128 – 70) * Per Thread Scratch Space

Bits [8:7] of the FFTID provide the subslice id; for each subslice we subtract the difference between the default separation between subslices and the minimum needed for a 10 EU and 7 threads per EU system.



Dispatch Payload

The payload for a general purpose thread will have to include the execution mask with a bit per 32-channel. SIMD16 and SIMD8 use the LSB bits of the execution mask. The 5-bit number transferred from VFE will be expanded to produce the 32-bit mask. This will use the Dmask currently used by the pixel shader dispatch in the transparent header.



Generic Media

This introduction provides a brief overview of the Media product features, which includes Media's functions, feature benefits, and how the features fit into graphics products as part of a whole solution. Media normally refers to products and services on digital computer-based systems that presents content, such as text, graphics, animation, video, audio, games, etc.

Media product features, as described in this PRM, include:

- Multi-format codec engine
- Video front end
- Media fixed functions
- Video encoding
- Video decoding
- Sampling

Media product features support specific applications, such as interactive gaming, videogames, social media, virtual reality, and augmented reality.

The following block diagram shows the Main Render Engine, unified for 3D graphics and Media.

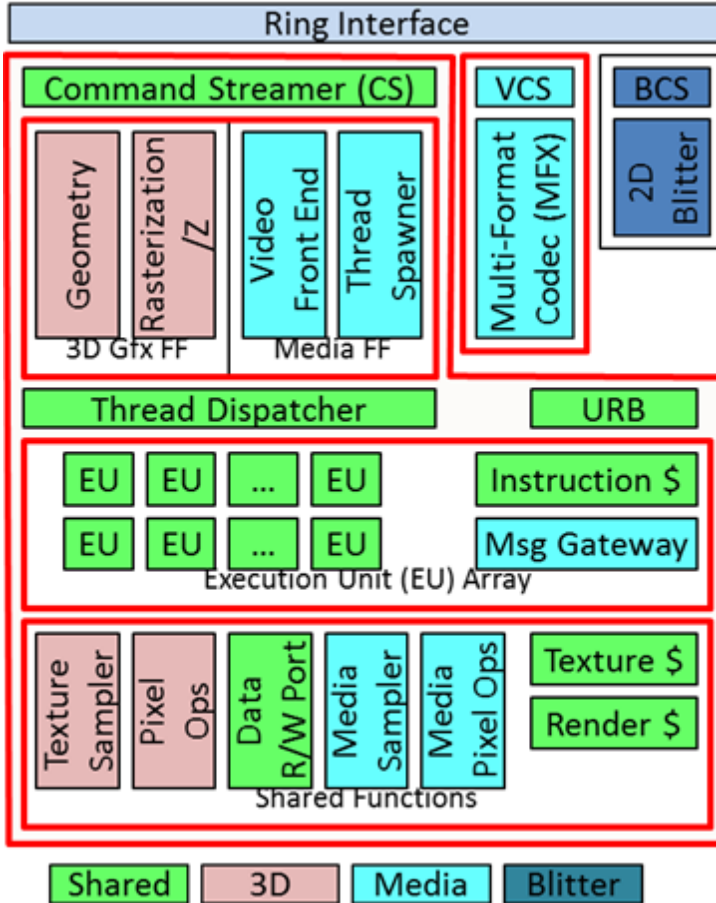

- **Fixed Function (FF) pipelines:** Provide thread generation and control.
- **3D graphics or Media FF** Controls EU array at a given time. The EU (Execution Unit) array is shared between 3D and Media and ISA is optimized for both.
- **Shared functions:** Include accelerators for filtered load, scatter, gather, and filter/blended store operations.
- **MFX:** A parallel codec engine that runs in a separate context.

Product Evolution

Block diagrams in this section describe the evolution of Media products, by project. They include definitions of the main components and how they integrate with each other.

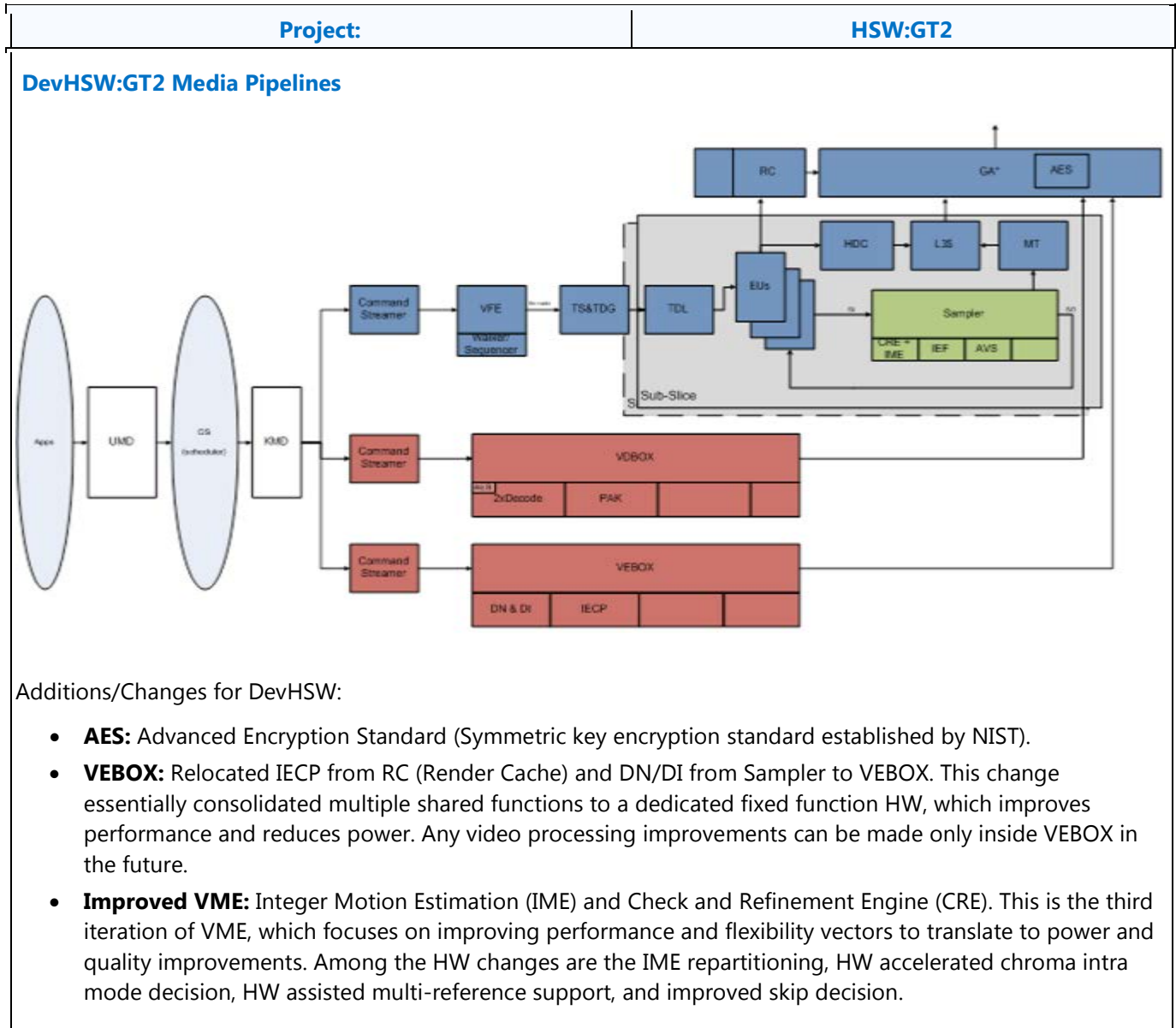



Media and General Purpose Pipeline

Introduction

This section covers the programming details for the media (general purpose) fixed function pipeline. The *media pipeline* is positioned in parallel with the 3D fixed function pipeline. It provides media functions and has media specific fixed function capability. However, the fixed functions are designed to have the general capability of controlling the shared functions and resources, feeding generic threads to the Execution Units to be executed, and interacting with these generic threads during run time. The media pipeline can be used for non-media applications, and therefore, can also be referred to as the *general purpose pipeline*. For the rest of this chapter, we refer to this fixed function pipeline as the media pipeline, keeping in mind its general purpose capability.

Concurrency of the media pipeline and the 3D pipeline is not supported. In other words, only one pipeline can be activated at a given time. Switching between the two pipelines within a single context is supported using the `ML_PIPELINE_SELECT` command.

Following are some media application examples that can be mapped onto the media pipeline. All these applications are functional; however, the level of performance that can be achieved depends on the hardware configuration and is beyond the scope of this document.

- MPEG-2 decode acceleration with HWMC (e.g. DXVA HWMC interface)
- MPEG-2 decode acceleration with IS/IDCT and forward (e.g. DXVA IDCT interface)
- MPEG-2 decode acceleration with VLD and forward (e.g. DXVA VLD interface)
- AVC decode acceleration with HWMC and forward including Loop Filter
- VC1 decode acceleration with HWMC and forward including Loop Filter
- Advanced deinterlace filter (motion detected or motion compensated deinterlace filter)
- Video encode acceleration (with various level of hardware assistant)

Terminologies

Term	Description	Security
AVC	Advanced Video Coding. An international video coding standard jointly developed by MPEG and ITU. It is also known as H.264 (ITU), or MPEG-4 Part 10 (MPEG).	
Child Thread	A thread corresponding to a leaf-node or a branch-node in a thread generation hierarchy. All thread originated from kernels running on the execution units are child threads.	
EOB	End of Block. It is a 1-bit flag in the non-zero DCT coefficient data structure indicating the end of an 8x8 block in a DCT coefficient data buffer.	
IDCT	Inverse Discrete Cosine Transform. It is the stage in the video decoding pipe between IQ and MC.	
IQ	Inverse Quantization. It is a stage in the video decoding pipe between IS and IDCT.	



Term	Description	Security
IT	Inverse Integer Transform. It is the stage in AVC or VC1 video decoding pipe between IQ and MC.	
MPEG	Motion Picture Expert Group. MPEG is the international standard body JTC1/SC29/WG11 under ISO/IEC that has defined audio and video compression standards such as MPEG-1, MPEG-2, and MPEG-4, etc.	
MC	Motion Compensation. It is part of the video decoding pipe.	
MVFS	Motion Vector Field Selection – a four-bit field selecting reference fields for the motion vectors of the current macroblock.	
PRT	<p>A persistent root thread in general stays in the system for a long period of time. It is normally a parent thread. Only one PRT is allowed in the system.</p> <p>Hardware is responsible for re-dispatching the incomplete PRT at context restore, and a PRT can continue operations from that previously left-over state.</p>	
Parent Thread	A thread corresponding to a root-node or a branch-node in thread generation hierarchy. A parent thread may be a root thread or a child thread depending on its position in the thread generation hierarchy.	
Root Thread	A thread corresponding to a root-node in a thread generation hierarchy. In the general-purpose pipeline, all threads originated from VFE unit are root threads.	
Synchronized Root Thread	A root thread that is dispatched by TS upon a 'dispatch root thread' message.	
TS	Thread Spawner. It is the second (and the last) fixed function in the general-purpose pipeline.	
Unsyncronized Root Thread	A root thread that is automatically dispatched by TS.	
VFE	Video Front End. It is the first fixed function in the general-purpose pipeline.	
VLD	Variable Length Decode. It is the first stage of the video decoding pipe that consists mainly of bit-wide operations. Hardware MPEG-2 VLD acceleration is supported in the VFE fixed function stage.	



Hardware Feature Map in Products

The following table lists the hardware features in the media pipe.

Video Front End Features in Device Hardware

Features/ Device	[DevSNB+]
Generic Mode	Y
Root Threads	Y
Parent/Child Threads	Y
SRT (Synchronized Root Threads)	Y
PRT (Persistent Root Thread)	Y
Interface Descriptor Remapping	N
IS Mode (HW Inverse Scan)	N
VLD Mode (HW MPEG2 VLD)	N
AVC MC Mode	N
AVC IT Mode (HW AVC IT)	N
AVC ILDB Filter (in Data Port)	N
VC1 MC Mode	N
VC1 IT Mode (HW VC1 IT)	N
Stalling HW Scoreboard	Y
Non-stalling HW Scoreboard	Y
HW Walker	Y
HW Timer	Y



Features/ Device	[DevSNB+]
Pipelined State Flush	Y
HW Barrier	Y



Media Pipeline Overview

The media (general purpose) pipeline consists of two fixed function units: Video Front End (VFE) unit and Thread Spawner (TS) unit. VFE unit interfaces with the Command Streamer (CS), writes thread payload data into the Unified Return Buffer (URB), and prepares threads to be dispatched through TS unit. VFE unit also contains a hardware Variable Length Decode (VLD) engine for MPEG-2 video decode. TS unit is the only unit of the media pipeline that interfaces to the Thread Dispatcher (TD) unit for new thread generation. It is responsible for spawning root threads (short for the root-node parent threads) originated from VFE unit and for spawning child threads (can be either a leaf-node child thread or a branch-node parent thread) originated from the Execution Units (EU) by a parent thread (can be a root-node or a branch-node parent thread).

The fixed functions, VFE and TS, in the media pipeline, in most cases, share the same basic building blocks as the fixed functions in the 3D pipeline. However, there are some unique features in media fixed functions as highlighted by the followings.

- VFE manages URB and only has write access to URB; TS does not interface to URB.
- When URB Constant Buffer is enabled, VFE forwards TS the URB Handler for the URB Constant Buffer received from CS.
- TS interfaces to TD; VFE does not.
- TS can have a message directed to it like other shared functions (and thus TS has a shared function ID), and it does not snoop the Output Bus as some other fixed functions in the 3D pipeline do.
- A root thread generated by the media pipeline can only have up to one URB return handle.
- If a root thread has a URB return handle, VFE creates the URB handle for the payload to initiating the root thread and also passes it alone to the root thread as the return handle. The root thread then uses the same URB handle for child thread generation.
- If URB Constant Buffer is enabled and an interface descriptor indicates that it is also used for the kernel, TS requests TD to load constant data directly to the thread's register space. For root thread, constant data are loaded after R0 and before the data from the other URB handle. For child thread, as the R0 header is provided by the parent thread, Thread Spawner splits the URB handles from the parent thread into two and inserts the constant data after the R0 header.
- A root thread must terminate with a message to TS. A child thread should also terminate with a message to TS.
- High streaming performance of indirect media object load is achieved by utilizing the large vertex cache available in the Vertex Fetch unit (of the 3D pipeline).

Top level block diagram of the Media Pipeline

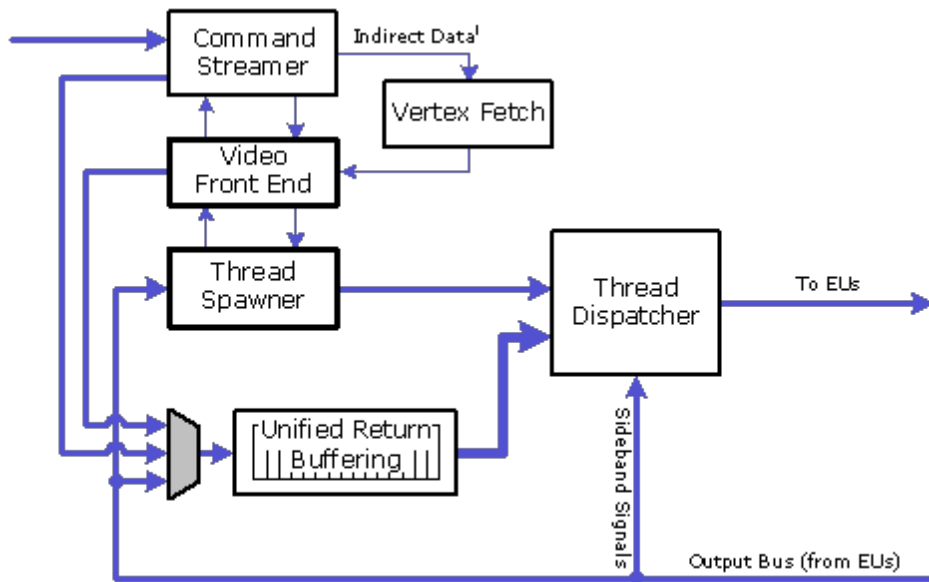

B6853-01

Generic Mode

In the Generic mode, VFE serves as a conduit for general-purpose kernels fully configured by the host software. As there is no special fixed function logic used, the Generic mode can also be viewed as a *pass-through* mode. In this mode, VFE generates a new thread for each MEDIA_OBJECT command. The payload contained in the MEDIA_OBJECT command (inline and/or indirect) is streamed into URB. The interface descriptor pointer is computed by VFE based on the interface descriptor offset value and the interface descriptor base pointer stored in the VFE state. VFE then forwards the interface descriptor pointer and the URB handle to TS to generate a new root thread. Many media processing applications can be supported using the Generic mode: MPEG-2 HWMC, frame rate conversion, advanced deinterface filter, to name a few.

GPGPU Media Pipe Differences

You can access the GPGPU pipe with the GPGPU_OBJECT and GPGPU_WALKER commands. A thread group id is associated with every dispatch, which is used to allocate and track barriers and Shared Local Memory. The GPGPU pipe has access to all the shared functions. The GPGPU pipe does not use the Scoreboard and should not dispatch child threads.

You can access the Media pipe with the various MEDIA_OBJECT* commands. Barriers and Shared Local Memory are not allocated for them. All shared functions are available. The Scoreboard is available to control dispatch depending on the completion of neighboring blocks.



Programming Media Pipeline

The Programming Media Pipeline is programmed with command sequences. The media hardware threads are created through the parameterized media walker. The dispatch of thread is controlled by a scoreboard mechanism.

Command Sequence

Media pipeline uses a simple programming model. Unlike the 3D pipeline, it does not support pipelined state changes. Any state change requires an MI_FLUSH or PIPE_CONTROL command. When programming the media pipeline, it should be cautious to not use the pipelining capability of the commands described in the Graphics Processing Engine chapter.

To emphasize the non-pipeline nature of the media pipeline programming model, the programmer should note that if any one command is issued in the *Primitive Command* step, none of the state commands described in the previous steps cannot be issued without preceding with a MI_FLUSH or PIPE_CONTROL command.

Note for [HSW]: With the addition of MEDIA_STATE_FLUSH command, pipelined state changes are allowed on the media pipeline. The MEDIA_STATE_FLUSH serves as a fence for state change by flushing the VFE/TS front ends but not waiting for threads to retire.

The basic steps in programming the media pipeline are listed below. Some of the steps are optional; however, the order must be followed strictly. Some usage restrictions are highlighted for illustration purpose. For details, refer to the respective chapters for these commands.

Command Sequence

The media pipeline is further simplified with fixed functions like MPEG2 VLD and AVC/VC1 IT removed. The addition includes:

1. The CURBE command is now unique to the media pipeline.
2. The interface descriptors are delivered directly as a media state command instead of being loaded through indirect state.

The programming model requires the following steps:

Step 1: MI_FLUSH/PIPE_CONTROL:

- This step is mandatory.
- Multiple such commands in step 1 are allowed, but not recommended for performance reasons.

Step 2: State command PIPELINE_SELECT:

- This step is optional. This command can be omitted if it is known that within the same context the media pipeline was selected before Step 1.
- Multiple such commands in step 2 are allowed, but not recommended for performance reasons.



Step 3: State commands configuring pipeline states:

- STATE_BASE_ADDRESS:
 - This command is mandatory for this step (i.e. at least one).
 - Multiple such commands in this step are allowed. The last one overwrites previous ones.
 - This command must precede any other state commands below.
 - Particularly, the fields **Indirect Object Base Address** and **Indirect Object Access Upper Bound** are used to control indirect Media object load in VF.
 - The fields **Dynamics Base Address** and **Dynamics Base Access Upper Bound** are used to control indirect Curbe and Interface Descriptor object load in VF.
 - **Note:** This command may be inserted before (and after) any commands listed in the previous steps (Step 1 and 2). For example, this command may be placed in the ring buffer while the others are put in a batch buffer.
- STATE_SIP:
 - This command is optional for this step. It is only required when SIP is used by the kernels.
- MEDIA_VFE_STATE:
 - This command is mandatory for this step (i.e. at least one).
 - This command cause destruction of all outstanding URB handles in the system. A new set of URB handles will be generated based on state parameters, no. of URB and URB length, programmed in VFE FF state.
 - Multiple such commands in this step are allowed. The last one overwrites previous ones.
- MEDIA_CURBE_LOAD:
 - This command is optional.
 - Multiple such commands in this step are allowed. The last one overwrites previous ones.
- MEDIA_INTERFACE_DESCRIPTOR_LOAD:
 - This command is mandatory for this step (i.e. at least one).
 - Multiple such commands in this step are allowed. The last one overwrites previous ones.

Step 4: Primitive commands:

- MEDIA_OBJECT:
 - This step is optional, but it does not make practical sense to not issue media primitive commands after going through the previous steps to set up the media pipeline.
 - Multiple such commands in step 4 can be issued to continue processing media primitives.

With the addition of MEDIA_STATE_FLUSH command, pipelined state changes are allowed on the media pipeline. To support context switch for barrier groups, watermark and barrier dependencies are added to the MEDIA_STATE_FLUSH command. The usage of barrier group may have strict restriction that all threads belonging to a barrier group must all be present to avoid deadlock during context switch. Here are the example programming sequences to allow context switch.



Project	Notes
HSW	The use of MEDIA_OBJECT_PRT and MI_ARB_ON_OFF are optional.

- MEDIA_VFE_STATE
- MEDIA_INTERFACE_DESCRIPTOR_LOAD
- MEDIA_CURBE_LOAD (optional)
- MEDIA_GATEWAY_STATE (for example for barrier group 1)
- MEDIA_OBJECT_PRT (with VFE_STATE_FLUSH set and PRT NEEDED set)
- MEDIA_STATE_FLUSH (with watermark set for group 1)
- MI_ARB_ON_OFF (OFF) // Arbitration must be turned off while sending objects for group 1
- Several MEDIA_OBJECT command (for barrier group 1)
- MI_ARB_ON_OFF (ON) // Arbitration is allowed
- MEDIA_STATE_FLUSH (optional, only if barrier dependency is needed)
- MEDIA_INTERFACE_DESCRIPTOR_LOAD (optional)
- MEDIA_CURBE_LOAD (optional)
- MEDIA_GATEWAY_STATE (for example for barrier group 2)
- MEDIA_STATE_FLUSH (with watermark set for group 1)
- MI_ARB_ON_OFF (OFF) // Arbitration must be turned off while sending objects for group 2
- Several MEDIA_OBJECT command (for barrier group 2)
- MI_ARB_ON_OFF (ON) // Arbitration is allowed
- ...
- MI_FLUSH

Commands for the GPGPU pipe (GPGPU_OBJECT and GPGPU_WALKER) should be separated from commands for the Media pipe (MEDIA_OBJECT*) by an MI_FLUSH.

Parameterized Media Walker

The Parameterized Media Walker is a hardware thread generation mechanism that creates threads associated with units in a generalized 2-dimensional space, for example, blocks in a 2D image. With a small number of unit step vectors, the walker can implement a large number of walking patterns as described hereafter. This command may provide functions that are normally handled by the host software, thus, may be used to simplify the host software and GPU interface.

The walker described herein is doubly nested, where essentially a *local* walker can perform a variety of 2-dimensional walking patterns and a *global* walker can perform similar 2-dimensional walking patterns upon many local walkers. The local walker has 3 levels (outer, middle, and inner) while the global walker has 2 levels (outer and inner). Thus, the algorithm has 5-nested loops that modify local state based on user-defined unit step vectors.

The Walker's programmability is derived from:



- The walker traverses a unit-normalized surface. Some example unit sizes:
 - 1x1: Walking pixels
 - 4x4: Walking sub-blocks
 - 16x16: Walking macro-blocks
 - 32x16: Walking macro-block-pairs
- The use of unit step vectors to describe the motion at each of level of nesting
- Starting locations for the local and global walkers
- Block sizes of the local and global walker
- And a small number of special mode controls for the inner-most loop which are aimed at efficiently dividing an image into two balanced workloads for dual-slice designs.

Walker Parameter Description

The global and local loops are both described by the same four parameters:

- Resolution,
- Starting location,
- Outer unit vector,
- Inner unit vector

The local inner loop has some special modes that will be described later. A table of the user inputs and some example values are given below:

GLOBAL LOOP PARAMETERS							
Global Resolution		Global Start		Outer Loop Unit Vector		Inner Loop Unit Vector	
X	Y	X	Y	X	Y	X	Y
120	68	0	0	32	0	0	32
LOCAL LOOP PARAMETERS							
Block Resolution		Local Start		Outer Loop Unit Vector		Inner Loop Unit Vector	
X	Y	X	Y	X	Y	X	Y
32	32	0	0	1	0	-2	2
LOCAL INNER LOOP SPECIAL MODE SELECTS							
Dual Mode	Repel	Attract			ExtraSteps	X	Y
TRUE	FALSE	FALSE			1	0	1

It should be emphasized that the value of what a *unit* represents is implicitly defined by the user. In other words, the walker traverses a *unit normalized space* that is not inherently bound to pixel walking. If the smallest unit of work the user wants to walk is a 4x3 block of pixels, you can program the inner loop to step (4,3) or (1,1):



- In the first case (4,3) the user is walking in units of pixels
- In the second case (1,1) the user is walking in units of 4x3 blocks of pixels.

It should be noted that hardware doesn't contain enough bits for pixel walking for pixel resolution like 1920x1088. The intended usage of the walker is for block walking whereas the block size is not relevant to the walker parameters.

Basic Parameters for the Local Loop

The local inner and outer loop xy-pair parameters alone can describe a large variety of primitive walking patterns. Below are 9 primitive walking patterns generated by varying only the inner and outer unit step vectors of the local loop:

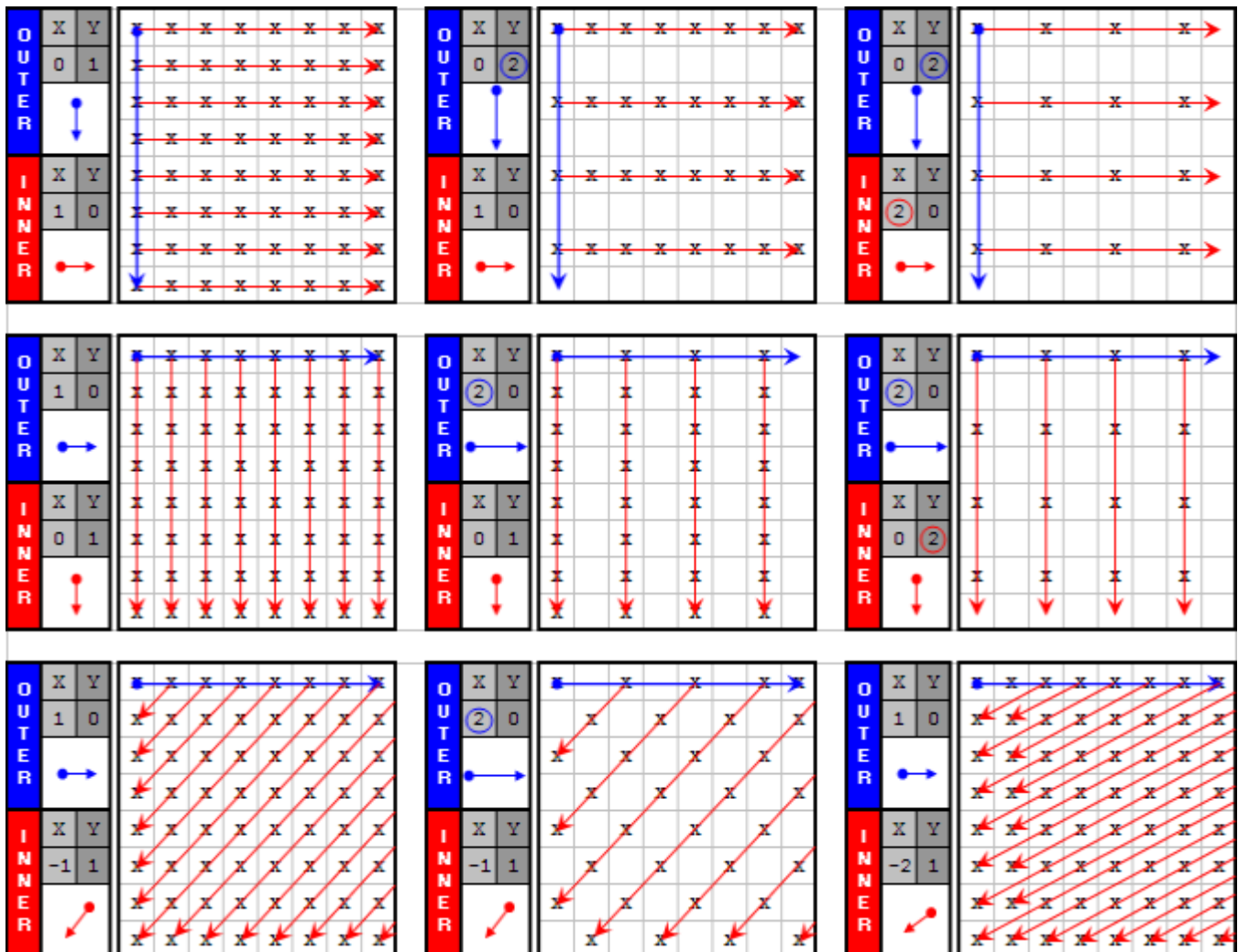

- The top row shows the outer unit vector pointing down (+Y) and the inner unit vector pointing right (+X). Rows and columns can easily be skipped by increasing the unit step vectors above one.
- The middle row the outer unit vector pointing right (+X) and the inner unit vector pointing down (+Y). Again, rows and columns are skipped by increasing the unit step vectors beyond one.

- The last row shows the capability to walk angles not perpendicular to the edge. The 1st shows a 45° walking pattern by setting the inner unit vector to (-1,1). The 2nd shows a checkerboard pattern by skipping every other outer loop and retaining the inner unit vector of (-1,1). The 3rd shows a 26.5° walking pattern by setting the inner unit vector to (-2,1).

The block resolution, shown as [8,8], and the starting location, currently [0,0], can be varied and the above patterns can be stretched and rotated many ways. The diagram below shows an example of where the start position and unit step vectors can be set to achieve a full rotation of the same pattern:

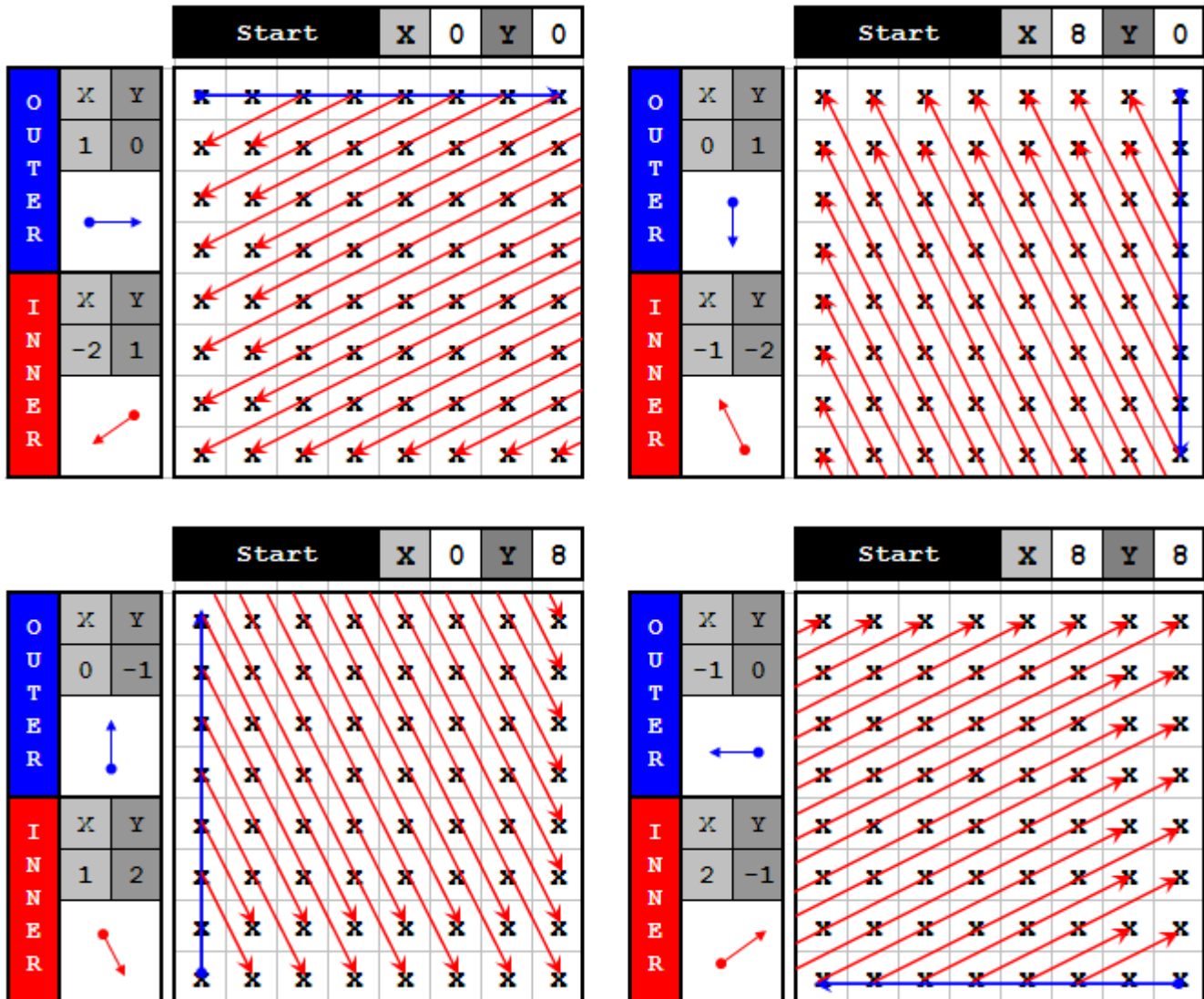

Dual Mode of Local Loop

The local Inner Loop Special mode selects are included to aid in the distribution of work, specifically with two slices in mind. Essentially, the local inner loop can be bisected and each half-walk can be directed inward towards the center of the image (dual). The local inner loop need not be bisected, and can either move away from the outer loop (repel) or move towards it (attract) when an even split is not desired:

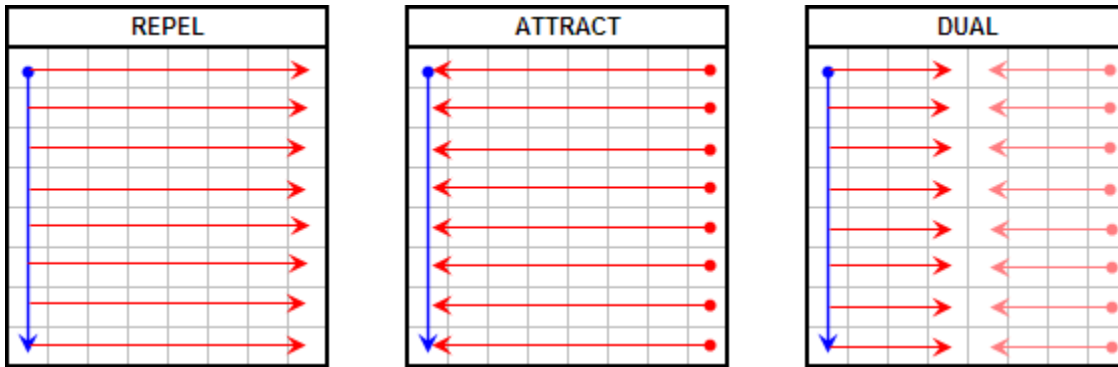

In Dual mode, the sequence will alternate between two half-walks such that every-other output would go to the same slice. This effect will produce a more balanced workload to two slices as shown in the example below where the color of the block represents which slice it was dispatched to. This is the walker's approach to fine-grained parallelism.

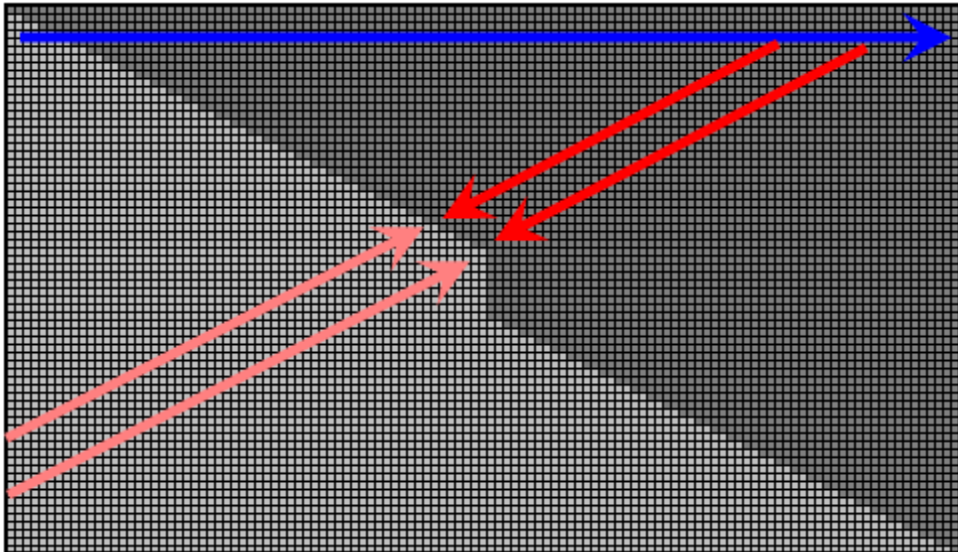

MbAff-Like Special Case in Local Loop

The local loop has an additional middle loop that is used to achieve some specific walking patterns, with MBAFF mode especially in mind. A pattern to handle MBAFF AVC content is to walk the top macroblock pairs (MB-pairs) on a wavefront followed by the respective bottom macroblocks. The pattern is shown below.



Walker(){ //C-Style Pseudo-Code of Walker Algorithm

```
    Load_Inputs_And_Initialize();
    While (Global_Outer_Loop_In_Bounds()){
        Global_Inner_Loop_Initialization();
        While (Global_Inner_Loop_In_Bounds()){
            Local_Block_Boundary_Adjustment();
            Local_Outer_Loop_Initialization();
            While (Local_Outer_Loop_In_Bounds()){
                Local_Middle_Loop_Initialization();
                While (Local_Middle_Steps_Remaining()){
                    Local_Inner_Loop_Initialization();
                    While (Local_Inner_Loop_Is_Shrinking()){
                        Execute();
                        Calculate_Next_Local_Inner_X_Y();
                    } //End Local Inner Loop
                    Calculate_Next_Local_Middle_X_Y();
                } //End Local Middle Loop
                Calculate_Next_Local_Outer_X_Y();
                Calculate_Next_Local_Inverse_Outer_X_Y();
            } //End Local Outer Loop
            Calculate_Next_Global_Inner_X_Y();
        } //End Global Inner Loop
        Calculate_Next_Global_Outer_X_Y();
    } //End Global Outer Loop
} //End Walker
```

The pseudo-code has the following characteristics:

- There are 5 levels of iteration
- The highest 2 levels are called *global* and the lowest 3 levels are called *local*
 - The global loop is split into an outer and an inner loop.
 - The local loop is split into an outer, a middle, and an inner loop.
 - A bounding box for the global and local resolution is defined by the user.



- The starting location within each bounding box is also specified by the user.
- Each of the 5 loops has its own persistent
 - Current position (x,y)
 - Unit step vector (x,y)
- The final output (x,y) is a summation of the global x,y and the local x,y .
- The next (x,y) for given level can be calculated while the next lower level is still executing. Additionally, the result can be used to check to see if the current level will execute again once control is returned.

The flow of the global outer and inner loops is:

1. Check a bound condition
2. Initialize the next level loop
3. Execute the next level loop
4. When the next level loop fails its condition, calculate the next position for the current loop level and repeat.

Walker algorithm flowchart for the Global Loop

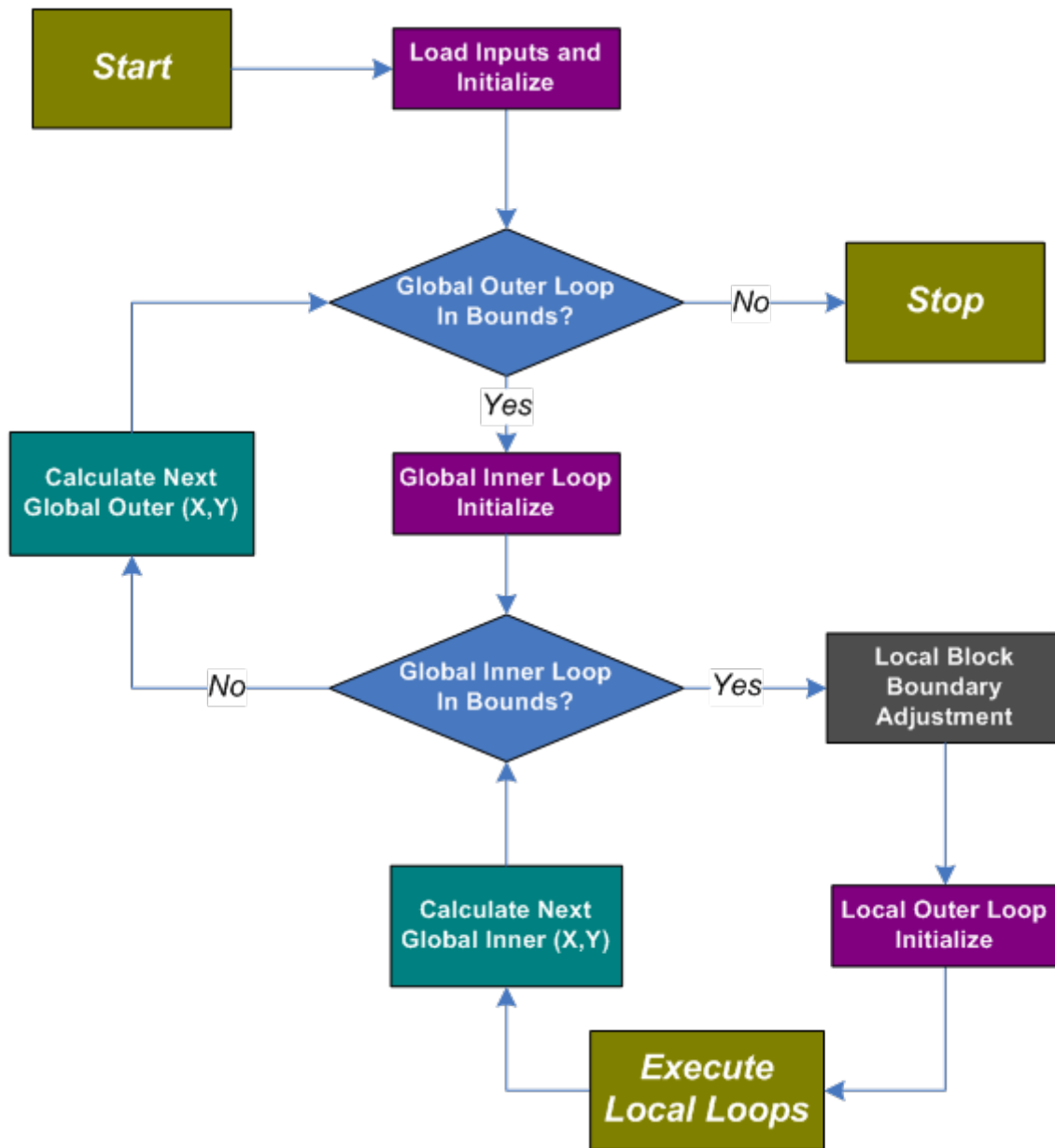

Take note of the grey box *Local Block Boundary Adjustment*. This logic is necessary to adjust the local block size when the distance between the current global position to the edge of the image is less than the local resolution. Additionally, the local starting positions might be modified here as well if the defined starting position is larger than the new local block size.

The flow of the 3 local loops does not vary much from the 2 global loops. The differences are:

- In addition to a boundary check, the local middle loop also ensures the number of middle steps is less than or equal to the user defined *number of extra steps*.



- The local inner loop only checks to see if the prior distance between the x,y starting and ending points are greater than their current distance. If this is true, it implies that the two inner loops are converging towards each other.
- When the middle loop check fails, both the starting points (local outer) and ending points (local inner) are updated.

Walker algorithm flowchart for the Local Loop

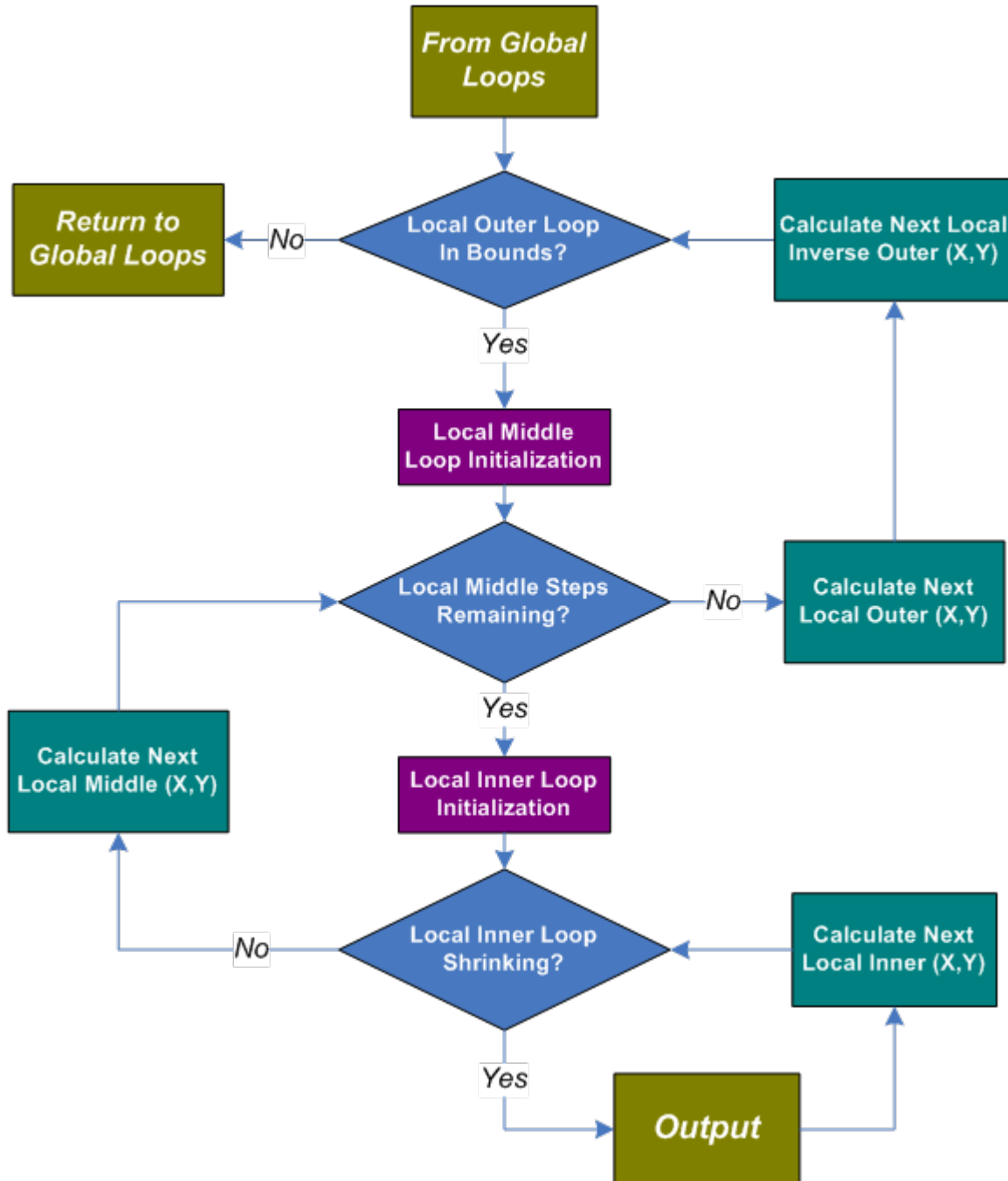



Scoreboard Control

A hardware mechanism controls the dispatch of root threads. Without using this hardware mechanism, only the dispatch of a SRT is managed by a parent root thread using the SRT message to TS.

There is a scoreboard hardware in TS unit. The scoreboard is addressed by the 18-bit (X, Y) scoreboard field in VFE DWord, where (X, Y) is typically used as the Cartesian coordinate of the working unit in a 2D frame but may be interpolated in other ways. When a root thread is dispatched, the entry at (X, Y) is marked. When the root thread is terminated, the corresponding bit in the scoreboard is cleared.

Each root thread may have up to eight dependencies. The dependency relation is described by the state value of Scoreboard Controls in terms of related distance of (ΔX , ΔY). There is a global scoreboard enabling in the state as well as the-per thread enabling for each dependency.

TS stalls the dispatch of a root thread if any scoreboard entry, which is denoted by (Scoreboard X + ΔX , Scoreboard Y + ΔY), matching with any enabled dependencies is marked as in-flight. The thread is dispatched only after all dependencies are cleared.

For a root thread, TS stalls the dispatch of the thread only if the dependent scoreboard entries of the thread are marked. It does not automatically stalls the dispatch for destination collision if ($\Delta X = 0$, $\Delta Y = 0$) is not set in the scoreboard state. This kind of scoreboard destination collision is due to the scoreboard wrap-around (or aliasing), which must be avoided. With 9-bit per X, Y field, the hardware scoreboard can support a frame that is subdivided up to 512x512 threads without a scoreboard aliasing.

In addition to the above *stalling scoreboard*, Media Pipe may also support a non-stalling scoreboard. With non-stalling, a thread is dispatched with the dependent threads marked. The thread dependency affects the issuing of a *sendc* instruction. See vol5d Execution Unit ISA for details.

Scoreboard Support in Device Hardware

Device	Stalling scoreboard	Non-Stalling scoreboard
[DevSNB+]	Yes	Yes

Restrictions:

- The hardware scoreboard only handles root threads, but not child threads. This limitation may be revisited when future application requirement changes.
- The usage of hardware scoreboard and SRT are mutually exclusive. In other words, when hardware scoreboard is used, SRT should not be issued.

AVC-Style Dependency Example

For AVD decoding, dependencies for a given macroblock may be set based on the availability of neighbor macroblocks, namely A, B, C, D and left-bottom neighbors (left-bottom only if MbAff = 1), as well as the current macroblock's address, MbAff flag and FieldMbFlag. For a macroblock in a progressive frame picture or a field picture, one macroblock may depend on up to four neighbors, A, B, C and D as shown in *AVC-Style Dependency Example*. For a macroblock in a MbAff pair, it may depend on up to



three, five or eight neighbors as shown in *AVC-Style Dependency Example* and *AVC-Style Dependency Example*, based on the current macroblock's address and FieldMbFlag.

The neighbor's availability depends on the corresponding **IntraPredAvailFlagA|B|C|D|E** flags for the macroblock (or the macroblock pair). Hardware assumes that the flags are set correctly in the MEDIA_OBJECT_EX command as shown in Macroblock indices for field picture destination. For simplicity, the left neighbor pair (A0 and A1) availability for a MbAff macroblock can be determined as a group by **IntraPredAvailFlagA | IntraPredAvailFlagE**. For the second macroblock in a *frame* MbAff pair, it depends on the first macroblock in the pair and it is always available.

Neighbor addresses of a macroblock in a progressive frame picture (MbAff = 0) or a field picture with up to 4 dependencies

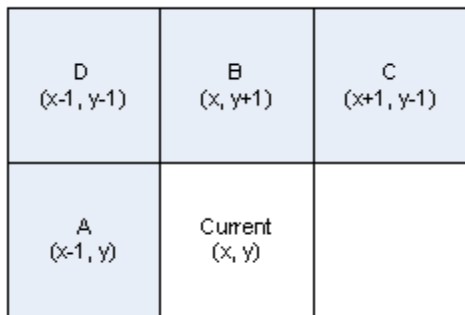

Neighbor addresses of the first macroblock in a MbAff frame picture (MbAff = 1) with up to 8 dependencies

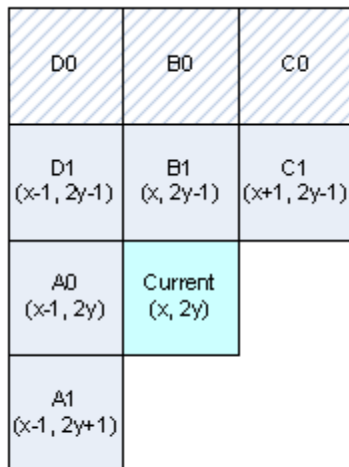

(a) Neighbors for the first macroblock in a 'frame' MbAff pair

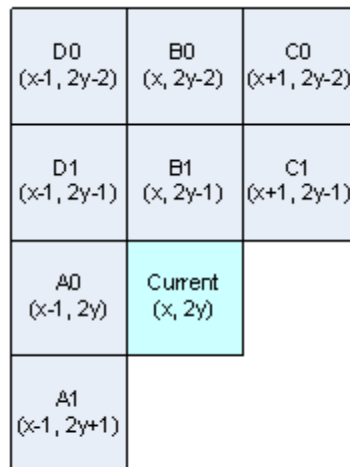

(b) Neighbors for the first macroblock in a 'field' MbAff pair

Neighbor addresses of the second macroblock in a MbAff frame picture (MbAff = 1) with up to 8 dependencies

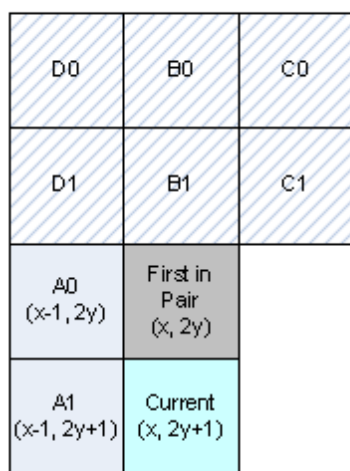

(b) Neighbors for the second macroblock in a 'frame' MbAff pair

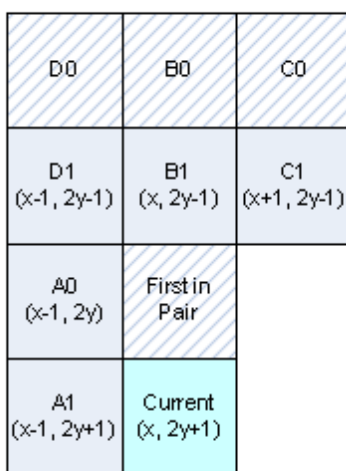

(b) Neighbors for the second macroblock in a 'field' MbAff pair

Neighbor Availability

MbAff	FieldMbFlag	VertOrigin[0]	A	B	C	D	LB	Comments
0	0/1	0/1	√	√	√	√	□	Progressive or Field picture
1	0	0	√	√	√	√	√	1 st Frame MbAff macroblock
1	0	1	√	na	0	na	√	2 nd Frame MbAff macroblock
1	1	0	√	√	√	√	√	1 st Field MbAff macroblock
1	1	1	√	√	√	√	√	2 nd Field MbAff macroblock

VC1-Style Dependency Example

For VC1, only one dependency may be set depending on the availability of the upper neighbor macroblock.

Macroblock sequence order in a VC-1 picture with WidthInMblk = 5 and HeightInMblk = 6

	0	1	2	3	4
0	0	1	2	3	4
1	5	6	7	8	9
2	10	11	12	13	14
3	15	16	17	18	19



	0	1	2	3	4
4	20	21	22	23	24
5	25	26	27	28	29

Multiple Slice Considerations

For products with multiple slices such as DevHSW:GT3, the Render Cache is separate per slice with no hardware coherency. This means that the programmer must ensure coherency by one of these methods:

- Using write commit when writing to the Render Cache.
- Using Data Cache instead of the Render Cache.
- Different slices only access separate cache lines. using a hashing algorithm combined with the slice select bits of the MEDIA_OBJECT/GPGPU_OBJECT commands.

Interrupt Latency

Command Streamer is capable of context switching between primitive commands.

For all independent threads, it is not much a problem. The interrupt latency is dictated by the longest command that is likely to have the largest number of threads. For VLD mode, such a command may be corresponding to a largest slice in a high definition video frame. This is application dependent, there are not much host software can do. For Generic mode, programmer should consider to constrain the compute workload size of each thread.

In modes with child threads, a root thread may persist in the system for long period of time – staying until its child threads are all created and terminated. Therefore, the corresponding primitive command may also last for long time. The Software designer should partition the workload to restrict the duration of each root thread. For example, this may be achieved by partitioning a video frame and assigning separate primitive commands for different data partitions.

In modes with synchronized root threads, a synchronized root thread is dependent on a previous root or child thread. This means context switch is not allowed between the primitive command for the synchronized root thread and the one for the depending thread. So no command queue arbitration should be allowed between them. Software designer should also restrict the duration of such non-interruptible primitive command segments.

Thread Spawner Unit

The Thread Spawner (TS) unit is responsible for making thread requests (root and child) to the Thread Dispatcher, managing scratch memory, maintaining outstanding root thread counts, and monitoring the termination of threads.

Thread Spawner block diagram

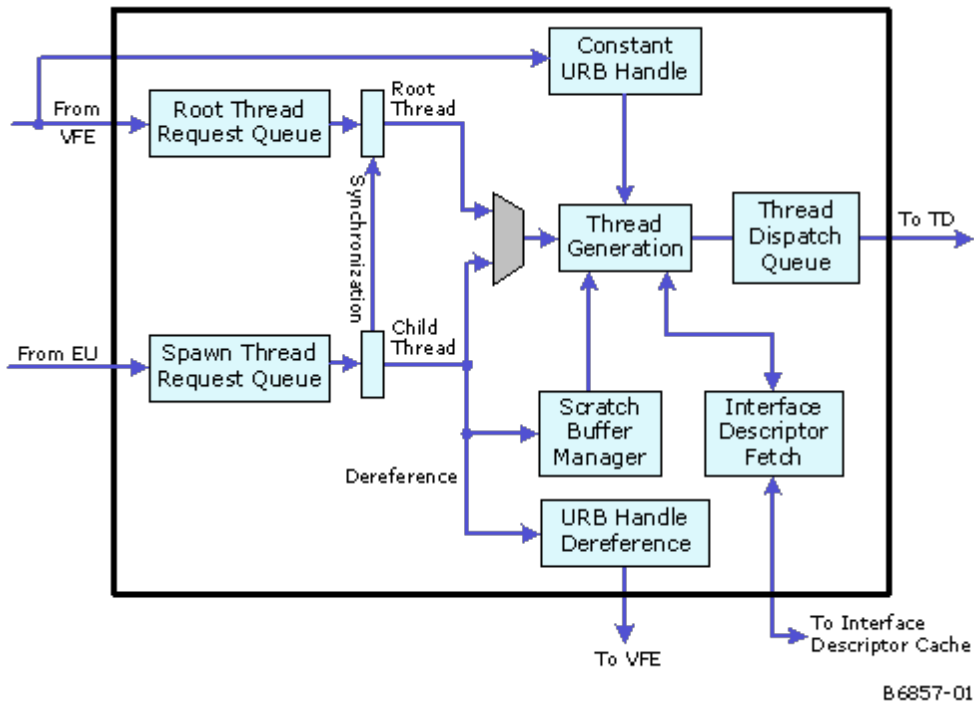



Root Threads and Child Threads

Thread requests sourced from VFE are called **root threads**. These threads may be creating subsequent child threads.

Root Threads

A root thread may be a macroblock thread created by VFE as in VLD mode, or may be a general-purpose thread assembled by VFE according to full description provided by host software in Generic mode. Thread requests are stored in the Root Thread Queue. TS keeps everything needed to get the root threads ready for dispatch and then tracks dispatched threads until their retirement.

TS arbitrates between root thread and child thread. The root thread request queue is in the arbitration only if the number of outstanding threads does not exceed the maximum root thread state variable. Otherwise, the root thread request queue is stalled until some other root threads retire/terminate.

Once a root thread is selected to be dispatched, its lifecycle can be described by the following steps:

1. TS forwards the interface descriptor pointer to the L1 interface descriptor cache (a small fully associated cache containing up to 4 interface descriptors). The interface descriptor is either found in the cache or a corresponding request is forwarded to the L2 cache. Interface descriptors return back to TS in requesting order.
 - Once TS receives the interface descriptor, it checks whether maximum concurrent root thread number has reached to determine whether to make a thread dispatch request or to stall the request until some other root threads retire. If the thread requests the use of scratch memory, it also generates a pointer into the scratch space.
2. TS then builds the transparent header and the R0 header.
3. Finally, TS makes a thread request to the Thread Dispatcher.
4. TS keeps track of dispatched thread, and monitors messages from the thread (resource dereference and/or thread termination). When it receives a root thread termination message, it can recover the scratch space and thread slot allocated to it. The URB handle may also be dereferenced for a terminated root thread for future reuse. It should be noted that URB handle dereference may occur before a root thread terminates. See detailed description in the Media Message section.
 - It is the root thread's responsibility (software) to guarantee that all its children have retired before the root thread can retire.

URB Handles

VFE is in charge of allocating URB handles for root threads. One URB handle is assigned to each root thread. The handle is used for the payload into the root thread.

Children Present is a command variable in the `_OBJECT` command.



If Children Present is not set (root-without-child case), TS signals VFE to dereference the URB handle immediately after it receives acknowledgement from TD that the thread is dispatched.

If Children Present is set (root-with-child case), the URB handle is forwarded to the root thread and serves as the return URB handle for the root thread. TS does not signal dereference at the time of dispatch. TS signals URB handle dereference only when it receives a resource dereference message from the thread.

Root to Child Responsibilities

Any thread created by another thread running in an EU is called a **child thread**. Child threads can create additional threads, all under the tree of a root which was requested via the VFE path.

A root thread is responsible of managing pre-allocated resources such as URB space and scratch space for its direct and indirect child threads. For example, a root thread may split its URB space into sections. It can use one section for delivering payload to one child thread as well as forwarding the section to the child thread to be used as return URB space. The child thread may further subdivide the URB section into subsections and use these subsections for its own child threads. Such process may be iterated. Similarly, a root thread may split its scratch memory into sections and give one scratch section for one child thread.

TS unit only enforces limitation on number of outstanding root threads. It is the root threads' responsibility to limit the number of child threads in their respected trees to balance performance and avoid deadlock.

Multiple Simultaneous Roots

Multiple root threads are allowed concurrently running in GEN4 execution units. As there is only one scratch space state variable shared for all root threads, all concurrent root thread requiring scratch space share the same scratch memory size. *Multiple Simultaneous Roots* depicts two examples of thread-thread relationship. The left graph shows one single tree structure. This tree starts with a single root thread that generates many child threads. Some child threads may create subsequent child threads. The right graph shows a case with multiple disconnected trees. It has multiple root threads, showing sibling roots of disconnected trees. Some roots may have child threads (branches and leafs) and some may not.

There is another case (as shown in *Multiple Simultaneous Roots*) where multiple trees may be connected. If a root is a synchronized root thread, it may be dependent on a preceding sibling root thread or on a child thread.

Examples of thread relationship

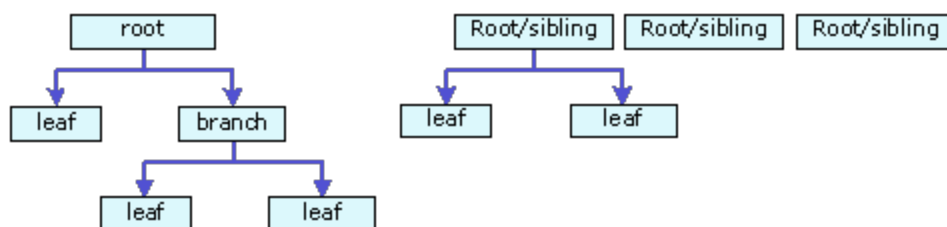

B6858-01



A example of thread relationship with root sibling dependency

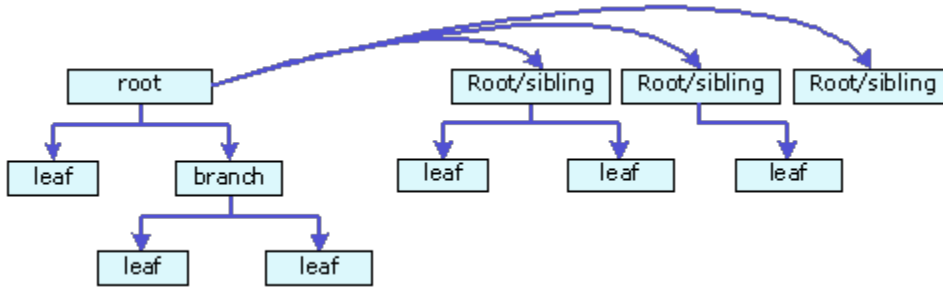

B6859-01

Synchronized Root Threads

A synchronized root thread (SRT) originates from a MEDIA_OBJECT command with Thread Synchronization field set. Synchronized root threads share the same root thread request queue with the non-synchronized roots. A SRT is not automatically dispatched. Instead, it stays in the root thread request queue until a spawn-root message is at the head of the child thread request queue. Conversely, a spawn-root message in the child thread request queue will block the child thread request queue until the head of root thread request queue is a SRT. When they are both at the head of queues, they are taken out from the queue at the same time.

A spawn-root message may be issued by a root thread or a child thread. There is no restriction. However, the number of spawn-root messages and the number of SRT must be identical between state changes. Otherwise, there can be a deadlock. Furthermore, as both requests are blocking, synchronized root threads must be used carefully to avoid deadlock.

When Scoreboard Control is enabled, the dispatch of a SRT originated from a MEDIA_OBJECT_EX command is still managed by the same way in addition to the hardware scoreboard control.

Deadlock Prevention

Root threads must control deadlock within their own child set. Each root is given a set of preallocated URB space; to prevent deadlock it must make sure that all the URB space is not allocated to intermediate children who must create more children before they can exit.

There are limits to the number of concurrent threads. The upper bound is determined by the number of execution units and the number of threads per EU. The actual upper bound on number of concurrent threads may be smaller if the GRF requirement is large. Deadlock may occur if a root or intermediate parent cannot exit until it has started its children but there is no space (for example, available thread slot in execution units) for its children to start.

To prevent deadlock, the maximum number of root threads is provided in VFE state. The Thread Spawner keeps track of how many roots have been spawned and prevents new roots if the maximum has been reached. When child threads are present, it is software's responsibility to constrain child thread generation, particularly the generation of child threads that may also spawn more child threads.



Child thread dispatch queue in TS is another resource that needs to be considered in preventing deadlock. The child thread dispatch queue in TS is used for (1) message to spawn a child thread, (2) message to spawn a synchronized root thread, and (3) thread termination message. If this queue is full, it will prevent any thread to terminate, causing deadlock.

For example, if an application only has one root thread (max # of root threads is programmed to be one). This root thread spawns child threads. In order to avoid deadlock, the maximum number of outstanding child thread that this root thread can spawn is the sum of the maximum available thread slots plus the depth of the child thread dispatch queue minus one.

$$\text{Max_Outstanding_Child_Threads} = (\text{Thread Slot Number} - 1) + (\text{TS Child Queue Depth} - 1)$$

Adding other root threads (synchronized and/or non-synchronized) to the above example, the situation is more complicated. A conservative measure may have to use to prevent deadlock. For example, the root thread spawning child threads may have to exclude the max number of root threads as in the following equation to compute the maximum number of outstanding child threads to be dispatched.

$$\text{Max_Outstanding_Child_Threads} = (\text{Thread Slot Number} - 1) + (\text{TS Child Queue Depth} - 1) - (\text{Max Root Threads} - 1)$$

Child Thread Life Cycle

When a (parent) thread creates a child thread, the parent thread behaves like a fixed function. It provides all necessary information to start the child thread, by assembling the payload in URB (including R0 header) and then sending a spawn thread message to TS with following data:

- An interface descriptor pointer for the child thread.
- A pointer for URB data

The interface descriptor for a child may be different from the parent – how the parent determines the child interface descriptor is up to the parent, but it must be one from the interface descriptor array on the same interface descriptor base address.

The URB pointer is not the same as a URB handle. It does not have an URB handle number and does not appear in any handle table. This is acceptable because the URB space is never reclaimed by TS after a child is dispatched, but rather when the parent releases its original handles and/or retires.

The child request is stored in the child thread queue. The depth of the queue is limited to 8, overrun is prevented by the message bus arbiter which controls the message bus. The arbiter knows the depth of the queue and will only allow 8 requests to be outstanding until the TS signals an entry has been removed.

As mentioned previously, child threads have higher priority over root threads. Once TS selects a child thread to dispatch, it follows these steps:

1. TS forwards the interface descriptor pointer to the L1 interface descriptor cache (a small fully associated cache containing up to 4 interface descriptors). The interface descriptor is either found in the cache or a corresponding request is forwarded to the L2 cache. Interface descriptors return back to TS in requesting order.



2. TS then builds the transparent header but not the R0 header.
3. Finally, TS makes a thread request to the Thread Dispatcher.
4. Once the dispatch is done, TS can forget the child – unlike roots, no bookkeeping is done that has to be updated when the child retires.

If more data needs to be transferred between a parent thread and its child thread than that can fit in a single URB payload, extra data must be communicated via shared memory through data port.

Arbitration between Root and Child Threads

When both root thread queue and child thread queue are both non-empty, TS serves the child thread queue. In other words, child threads have higher priority over root threads. The only condition that the child thread queue is stalled by the root thread queue is that the head of child thread queue is a root-synchronization message and the head of root thread queue is not a synchronized root thread.

Persistent Root Thread

A persistent root thread in general stays in the system for a long period of time. It is normally a parent thread, and only one PRT is allowed in the system at a time.

Because only one PRT can execute at a time, once the next PRT starts, the previous one will never be restarted, thus the context save surface can be reused from one PRT to the next.

A PRT may check the Thread Restart Enable bit in the R0 header to find out whether it is a fresh start or resumed from a previous interrupt and then can continue operations from that previously saved context.

A PRT can be interleaved with other root (such as parent root thread, or synchronized root thread) and child threads. A parent root thread is not necessarily a PRT, and doesn't have to be as long as it can be finished in deterministic time that is shorter than required for fine-grain context switch interrupt.

Use of PRT must follow the following rule:

- There can only be one PRT in the media pipeline at a given time. That means, there shall not be any other media primitive commands (MEDIA_OBJECT or MEDIA_OBJECT_EX) between it and the previous MI_FLUSH command. In other words, when multiple such PRTs are used in a sequence of media primitive commands, MI_FLUSH must be inserted.



Media State Model

The media state model is based on in-line state load mechanism. VFE state, URB configuration and Interface Descriptors are loaded to VFE hardware through state commands.

All Interface Descriptors have the same size and are organized as a contiguous array in memory. They can be selected by Interface Descriptor Index for a given kernel. This allows different kinds of kernels to coexist in the system.

Pipeline (Media) Bits[28:27]	Opcode Bits[26:24]	Sub Opcode Bits[23:16]	Command
2h	0h	00h	MEDIA_VFE_STATE
2h	0h	01h	MEDIA_CURBE_LOAD
2h	0h	02h	MEDIA_INTERFACE_DESCRIPTOR_LOAD



Media State and Primitive Commands

This section contains various commands for media, all with the RenderCS source.

MEDIA_VFE_STATE

MEDIA_CURBE_LOAD

MEDIA_INTERFACE_DESCRIPTOR_LOAD

Interface Descriptor Data payload as pointed to by the Interface Descriptor Data Start Address:

INTERFACE_DESCRIPTOR_DATA

MEDIA_STATE_FLUSH

Project	Security	Programming Note
		The MEDIA_STATE_FLUSH command is updated to optionally specify all the resources required for the next thread group via an interface descriptor – if the resources are not available the group cannot start.

The MEDIA_OBJECT command is the basic media primitive command for the media pipeline. It supports loading of inline data as well as indirect data. At least one form of payload (either inline, indirect, or CURBE) must be sent with the MEDIA_OBJECT.

MEDIA_OBJECT

MEDIA_OBJECT_PRT

The MEDIA_OBJECT_WALKER command uses the hardware walker in VFE for generating threads associated with a rectangular shaped object. It only supports loading of inline data or CURBE but not indirect data. At least one form of payload must be sent. Control of scoreboards (up to 8) is implicit based on the (X, Y) address of the generated thread and the scoreboard control state.

The command can be used only in Generic modes.

When **Use Scoreboard** field is set, the (X, Y) address and the Color field of the generated thread are used in the hardware scoreboard and the thread dependencies are set by states from the MEDIA_VFE_STATE command.

One or more threads may be generated by this command. This command does not support indirect object load. When inline data is present, it is repeated for all threads it generates. Unlike CURBE, which requires pipeline flush for change, continued change of this kind of 'global' (in the sense of shared by multiple threads from this command) data is supported when MEDIA_OBJECT_WALKER commands are issued without a pipeline flush in between.

MEDIA_OBJECT_WALKER



Media Messages

All message formats are given in terms of dwords (32 bits) using the following conventions:

- Dispatch Messages: **R**p.d
- SEND Instruction Messages: **M**p.d

Thread Payload Messages

The root thread's register contents differ from that of child threads, as shown in *Thread Payload Messages*. The register contents for a synchronized root thread (also referred to as *spawned root thread*) and an unsynchronized one are also different. Whether the URB Constant data field is present or not is determined by the interface descriptor of a given thread. This applies to both root and child threads. When URB Constant data field is present for a synchronized root thread, URB constant data field is before the data field received from the spawning thread, which is also before the URB payload data.

Thread payload message formats for root and child threads

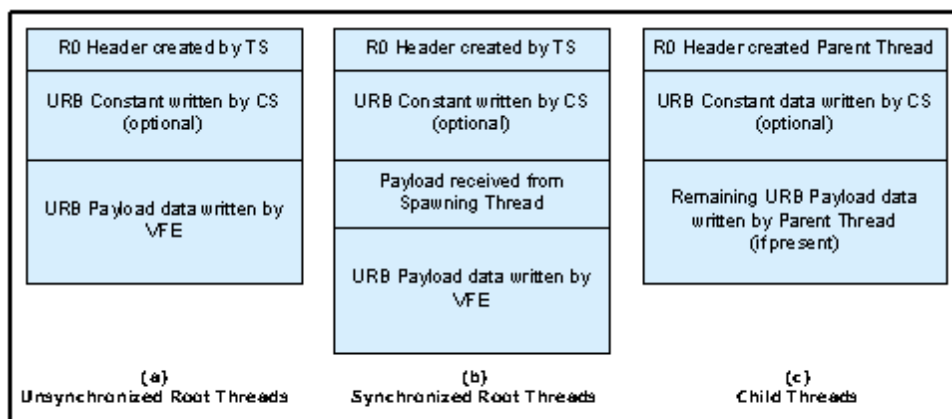

B.6863-01

Generic Mode Root Thread

The following table shows the R0 register contents for a Generic mode root thread, which is generated by TS. The remaining payloads are application dependent.

R0 Header of a Generic Mode Root Thread

DWord	Bits	Description	Project	Security
R0.5	31:10	Scratch Space Pointer. Specifies the 1k-byte aligned pointer to the scratch space. This field is only valid when Scratch Space is enabled. Format = GeneralStateOffset[31:10]		
	9:8	Reserved: MBZ		



DWord	Bits	Description	Project	Security
	7:0	<p>FFTID. This ID is assigned by TS and is a unique identifier for the thread in comparison to other concurrent root threads. It is used to free up resources used by the thread upon thread completion.</p> <p>Format = U8</p>		
R0.4	31:5	<p>Binding Table Pointer. The 32-byte aligned pointer to the Binding Table. It is specified as an offset from the Surface State Base Address.</p> <p>Format = SurfaceStateOffset[31:5]</p>		
	4:0	Reserved: MBZ		
R0.3	31:5	<p>Sampler State Pointer. Specifies the 32-byte aligned pointer to the sampler state table.</p> <p>Format = GeneralStateOffset[31:5]</p>		
	4	Reserved: MBZ		
	3:0	<p>Per Thread Scratch Space. The amount of scratch space, in 1K-byte quantities, allowed to be used by this thread. The value specifies the power that two is raised to, to determine the amount of scratch space.</p> <p>Format = U4</p> <p>Range = [0,11] indicating [1K bytes, 2M bytes] in powers of two</p>		
R0.2	31:28	Reserved: MBZ		
	27:16	Reserved: MBZ		
	15:10	Reserved: MBZ		
	9:4	<p>Interface Descriptor Offset. The offset from the interface descriptor base pointer to the interface descriptor that applies to this object, in units of interface descriptors.</p> <p>Format = U6</p>		
	3:0	<p>Scoreboard Color (only with MEDIA_OBJECT_EX): This field specifies which dependency color the current thread belongs to. It affects the dependency scoreboard control.</p>		



DWord	Bits	Description	Project	Security
		Format = U4		
R0.1	31:28	Reserved: MBZ		
	27:26	Reserved: MBZ		
	25	Reserved: MBZ		
	24:16	Scoreboard Y. This field provides the Y term of the scoreboard value of the current thread. Format = U9		
	15:12	Reserved: MBZ		
	11:9	Reserved: MBZ		
	8:0	Scoreboard X. This field provides the X term of the scoreboard value of the current thread. Format = U9		
R0.0	31:24	Scoreboard Mask. Each bit indicates the corresponding dependency scoreboard is dependent on. This field is AND'd with the corresponding Scoreboard Mask field in the MEDIA_VFE_STATE. Bit n (for n = 0...7): Scoreboard n is dependent, where bit 24 maps to n = 0. Format = TRUE/FALSE		
	23:16	Reserved: MBZ		
	15:0	URB Handle. This is the URB handle indicating the URB space for use by the root thread and its children.		

Root Thread from MEDIA_OBJECT_PRT

The root thread payload message for a MEDIA_OBJECT_PRT command has a fixed format independent of the VFE mode (e.g. Generic mode or AVC-IT mode). One example GRF register location is given for the condition that CURBE is disabled.

Root Thread Payload Layout for a MEDIA_OBJECT_PRT Command

GRF Register	Example	Description
R0	R0	R0 header
R1 – R(m)	N/A	Constants from CURBE when CURBE is enabled



GRF Register	Example	Description
		m is a non-negative value.
R(m+1)	R1	In-line Data block.

The R0 header field is as the following, which is the same as in other modes except the Thread Restart Enable bit (bit 0 of R0.2).

R0 Header of the Thread Payload of a MEDIA_OBJECT_PRT Command

DWord	Bit	Description	Security
R0.5	31:10	Scratch Space Pointer. Specifies the 1K-byte aligned pointer to the scratch space. This field is only valid when Scratch Space is enabled. Format = GeneralStateOffset[31:10]	
	9:8	Reserved: MBZ	
	7:0	FFTID. This ID is assigned by TS and is a unique identifier for the thread in comparison to other concurrent root threads. It is used to free up resources used by the thread upon thread completion.	
R0.4	31:5	Binding Table Pointer: Specifies the 32-byte aligned pointer to the Binding Table. It is specified as an offset from the Surface State Base Address. Format = SurfaceStateOffset[31:5]	
	4:0	Reserved: MBZ	
R0.3	31:5	Sampler State Pointer. Specifies the 32-byte aligned pointer to the sampler state table. Format = GeneralStateOffset[31:5]	
	4	Reserved: MBZ	
	3:0	Per Thread Scratch Space. Specifies the amount of scratch space, in 1K-byte quantities, allowed to be used by this thread. The value specifies the power that two is raised to, to determine the amount of scratch space. Format = U4 Range = [0,11] indicating [1K bytes, 2M bytes] in powers of two	
R0.2	31:4	Interface Descriptor Pointer. Specifies the 16-byte aligned pointer to <i>this thread's</i> interface descriptor. Can be used as a base from which to offset child thread's interface descriptor pointers. Format = GeneralStateOffset[31:4]	
	3:1	Reserved: MBZ	
	0	Thread Restart Enable. If set, indicates that the persistent root thread	



DWord	Bit	Description	Security
		(PRT) is being restarted, and context should be restored from the context save area before executing. Format = Enable	
R0.1	31:0	Reserved: MBZ	
R0.0	31:16	Reserved: MBZ	
	15:0	URB Handle. This is the URB handle indicating the URB space for use by the root thread and its children.	

The inline data block field is the same as in the MEDIA_OBJECT_EX command with zero-filled partial GRF.

Root Thread from MEDIA_OBJECT_WALKER

The root thread payload message for an MEDIA_OBJECT_WALKER command, which must be in Generic mode, has the same format as that of the generic mode root thread format.

Root thread payload layout for a MEDIA_OBJECT_WALKER command

GRF Register	Example	Description
R0	R0	R0 header
R1 – R(m)	n/a	Constants from CURBE when CURBE is enabled m is a non-negative value
R(m+1)	R1	In-line Data block.

The R0 header field is identical to that of Generic Mode Root Thread.

The inline data block field is the same as in the MEDIA_OBJECT command with zero-filled partial GRF.

There is no indirect data block field.

Thread Spawn Message

The thread spawn message is issued to the TS unit by a thread running on an EU. This message contains only one 8-DWord register. The thread spawn message may be used to:

- Spawn a child thread.
- Spawn a root thread (start dispatching a synchronized root thread).
- Dereference an URB handle.
- Indicate a thread termination, dereference other TS managed resource and may or may not dereference URB handle.
- Release a PRT_Fence.



To end a root thread, the end of thread message must be targeted at the thread spawner. In this case, the root thread sends a message with a "dereference resource" in the Opcode field. The thread spawner does *not* snoop the messages sideband to determine when a root thread has ended. Thread Spawner does not track when a child thread terminates, to be consistent a child thread should also terminate with a "dereference resource" message to the Thread Spawner. Software must set the Requester Type (root or child thread) field correctly.

TS dispatches one synchronized root thread upon receiving a 'spawn root thread' message (from a synchronization thread). The synchronizing thread must send the number of 'spawn root thread' message exactly the same as the subsequent 'synchronized root thread'. No more, no less. Otherwise, hardware behavior is undefined.

URB Handle Offset field in this message (in M0.4) has 10 bits, allowing addressing of a large URB space. However, when a parent thread writes into the URB, it subjects to the maximum URB offset limitation of the URB write message, which is only 6 bits (see Unified Return Buffer Chapter for details). In this case, the parent thread may have to modify the URB Return Handle 0 field of the URB write message to subdivide the large URB space that the thread manages.

Only a persistent root thread can use this message to dispatch a root thread if preemption exceptions are possible. The root thread requested by this message is not guaranteed to dispatch, and the persistent root thread must handle the case where it does not dispatch. When a context switch interrupt is recognized by the persistent root thread, all other root threads that had been dispatched have completed and no more will be dispatched. Child threads requested by this message are guaranteed to dispatch in all cases, so long as the persistent root thread does not also dispatch synchronized root threads. A child thread does not dispatch if it is behind a synchronized root thread that is not dispatched due to a preemption exception.

In addition to monitor 'end of thread message' targeted to Thread Spawner, Thread Spawner also monitors the message targeting to Message Gateway for EOT signal. Therefore, a child thread, who doesn't hold any hardware resource (URB handle or scratch memory) that Thread Spawner manages, can terminate with a Gateway message with EOT on. The reason of this new TS feature is to avoid a possible risk condition as described below.

In a system running child threads, a parent thread is monitoring the status of the child threads by communications through Message Gateway. When a child thread is about to terminate, it sends a message to the parent through Message Gateway and then sends a second message of EOT (end of thread) to TS.

There is a latency between sending a message to parent thread and the EOT to TS due to message bus arbitration. The parent thread may acknowledge the GW message and issue a new child dispatch before the EOT was processed; basically threads are issued faster than retired.

Because the messages for new child dispatch and EOT go to the same queue in TS, if the queue gets full, EOTs will get blocked. In the case when all the EUs/Threads are full, this will create a system deadlock: no EOTs can be acknowledged by TS (to free up EU resource) and no child threads can be dispatched (to free up TS queue to receive EOT message).



Message Descriptor

The following table shows the lower 20 bits of the message descriptor within the SEND instruction for a thread spawn message.

Thread Spawn Message Descriptor

Message Payload

DWord	Bits	Description	Project	Security
M0.5	31:8	Ignored.		
	7:0	<p>FFTID. This ID is assigned by TS and is a unique identifier for the thread in comparison to other concurrent root threads. It is used to free up resources used by a root thread upon thread completion.</p> <p>This field is valid only if the Opcode is "dereference resource", and is ignored by hardware otherwise.</p>		
M0.4	31:16	Ignored.		
	15:10	<p>Dispatch URB Length. Indicates the number of 8-DWord URB entries contained in the Dispatch URB Handle that will be dispatched. When spawning a child thread, the URB handle contains most of the child thread's payload including the R0 header. When spawning a root thread, the URB handle contains the message passed from the requesting thread to the spawned "peer" root thread. The number of GRF registers that are initialized at the start of the spawned child thread is the sum of this field and the number of URB constants if present. The number of GRF registers that are initialized at the start of a spawned root thread is the sum of this field, the number of URB constants if present, and the URB handle received from VFE.</p> <p>This field is ignored if the Opcode is "dereference resource".</p> <p>A Length of 0 can be used while spawning child threads to indicate that there is no payload beyond the required R0 header. A Length of 0 while spawning a root thread indicates that there is no payload at all from the parent thread. A spawned root has R0 supplied by the Media_Object</p>		



DWord	Bits	Description	Project	Security
		<p>command indirect/inline data.</p> <p>Format = U6</p> <p>Range = [0,63] for child threads.</p>		
	9:0	<p>URB Handle Offset. Specifies the 8-DWord URB entry offset into the URB handle that determines where the associated dispatch payload will be retrieved from when the spawned child or root thread is dispatched.</p> <p>This field is ignored if the Opcode is "dereference resource".</p> <p>Format = U10</p> <p>Range = [0,1023]</p>		
M0.3	31:0	Ignored.		
M0.2	31:28	Ignored.		
	27:24	<p>BarrierID. This field indicates which one of the 16 Barriers this kernel is associated with.</p> <p>Format: U4</p>		
	23:16	Ignored.		
	15:10	Ignored.		
	9:4	<p>Interface Descriptor Offset. This field specifies the offset from the interface descriptor base pointer to the interface descriptor that is applied to this object. It is specified in units of interface descriptors.</p> <p>Format = U6</p>		
	3:0	<p>Scoreboard Color (only with MEDIA_OBJECT_EX). This field specifies which dependency color the current thread belongs to. It affects the dependency scoreboard control.</p> <p>Format = U4</p>		
M0.1	31:0	Ignored.		
M0.0	31:28	Ignored.		
	27:24	<p>Shared Local Memory Index. Indicates the starting index for the shared local</p>		



DWord	Bits	Description	Project	Security
		memory for the thread group. Each index points to the start of a 4K memory block, 16 possibilities cover the entire 64K shared memory per half-slice. Format = U4		
	23:16	Reserved: MBZ		
	15:0	Dispatch URB Handle. If Opcode (and Requester Type) is "spawn a child thread": Specifies the URB handle for the child thread. If Opcode (and Requester Type) is "spawn a root thread": Specifies the URB handle containing message (e.g. requester's gateway information) from the requesting thread to the spawned root thread. If Opcode is "dereference resource": This field is required on end of thread messages if the Children Present bit is set, as the handle must be dereferenced, otherwise this field is ignored.		



EU Overview

The GEN instruction set is a general-purpose data-parallel instruction set optimized for graphics and media computations. Support for 3D graphics API (Application Programming Interface) Shader instructions is mostly native, meaning that GEN efficiently executes Shader programs. Depending on Shader program operation modes (for example, a Vertex Shader may be executed on a base of a vertex pair, while a Pixel Shader may be executed on a base of a 16-pixel group), translation from 3D graphics API Shader instruction streams into GEN native instructions may be required. In addition, there are many specific capabilities that accelerate media applications. The following feature list summarizes the GEN instruction set architecture:

- SIMD (single instruction multiple data) instructions. The maximum number of data elements per instruction depends on the data type.
- SIMD parallel arithmetic, vector arithmetic, logical, and SIMD control/branch instructions.
- Instruction level variable-width SIMD execution.
- Conditional SIMD execution via destination mask, predication, and execution mask.
- Instruction compaction.
- An instruction may be executed in multiple cycles over a SIMD execution pipeline.
- Most GEN instructions have three operands. Some instructions have additional implied source or destination operands. Some instructions have explicit dual destinations.
- Region-based register addressing.
- Direct or indirect (indexed) register addressing.
- Scalar or vector immediate source operand.
- Higher precision accumulator registers are architecturally visible.
- Self-modifying code is not allowed (instruction streams, including instruction caches, are read-only).

CoIssue/Dual Issue:

The Gen7 generation of EU allows two instructions to be issued at the same time (sometimes referred to as *dual-issue* or more generally *co-issue*). The two instructions issued are always from different threads. The terms *FPU Pipe* and *EM Pipe* are the terms used when referring to the two simultaneous pipes. The Gen7 implementation dual-issue capability is limited to only the most popular instructions and source operand modes. Later generations of EU expand on this concept to allow more operations.

Description:

- Opcodes: add, mov, mad, mul, cmp
- Datatype: single precision floats.
- Accessmode:
 - Align1:



- No Scattering or Gathering data. This means data in source and destination registers are aligned and packed (data is contiguous in a register).

```
//Example:  
// allowed, data is contiguous and source and destination regioning map one  
to one.  
mov (8) r10.0:f r11.0<8;8,1>:f  
// not allowed, data from source is strided and requires gathering to write  
to destination  
mov (8) r10.0:f r11.0<4;4,2>:f  
// not allowed, data from source is contiguous but not aligned with  
destination. Destination register requires scattering  
mov (8) r10.0<2>:w r11.0<8;8,1>:w  
//not allowed, data from source is contiguous but destination is not aligned  
to source  
mov (8) r10.1:f r11.0<4;4,1>:f  
// allowed. Source and destination have stride but are aligned  
mov (4) r10.1:f r11.1<4;4,1>:f
```

- A single precision float scalar is allowed.
 - Align16
- Addressmode: Direct Addressing
- Register File: GRF/NULL. No access to Accumulator.
- Condition modifiers supported only for cmp.



Primary Usage Models

In describing the usage models of the GEN instruction set, the following sections forward reference terminology, syntax, and instructions described later in this specification. For clarity reasons, not all forward references are explained at the point of reference. See the [Instruction Set Summary](#) chapter for information about instruction fields and syntax.

AOS and SOA Data Structures

With the Align1 and Align16 access modes, the GEN instruction set provides effective SIMD computation whether data is arranged in array of structures (AOS) form or in structure of arrays (SOA) form. The AOS and SOA data structures are illustrated by the examples in *AOS and SOA Data Structures*. The example shows two different ways of storing four vectors in four SIMD registers. For simplicity, the data vector and the SIMD register both have four data elements. The four data elements in a vector are denoted by X, Y, Z, and W just as for a vertex in 3D geometry. The AOS structure stores one vector in a register and the next vector in another register. The SOA structure stores one data element of each vector in a register and the next element of each vector in the next register and so on. The two structures can be related by a matrix transpose operation.

AOS and SOA Data Structures

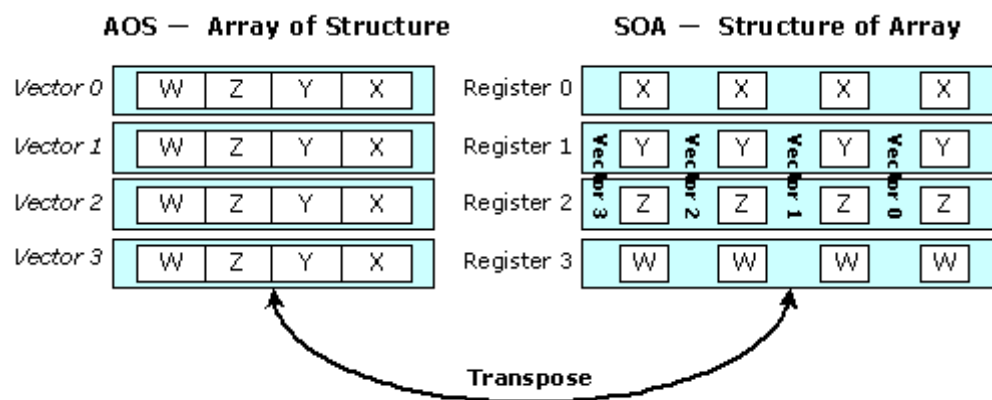

B6890-01

GEN 3D and media applications take advantage of such broad architecture support and use both AOS and SOA data arrangements.

- Vertices in 3D Geometry (Vertex Shader and Geometry Shader) are arranged in AOS form and use SIMD4x2 and SIMD4 modes, respectively, as detailed below.
- Pixels in 3D Rasterization (Pixel Shader) are arranged in SOA form and use SIMD8 and SIMD16 modes as detailed below.
- Pixels in media are primarily arranged in SOA form, and occasionally in AOS form with possibly mixed modes of operation that uses region-based addressing extensively.

These are preferred methods; alternative arrangements may also be possible. Shared function resources provide data transpose capability to support both modes of operations: The sampler has a transpose for sample reads, the data port has a transpose for render cache writes, and the URB unit has a transpose for URB writes.

The following 3D graphics API Shader instruction is used in the following sections to illustrate various operation modes:

```
add dst.xyz src0.yxzw src1.zwxy
```



This example is a SIMD instruction that takes two source operands `src0` and `src1`, adds them, and stores the result to the destination operand `dst`. Each operand contains four floating-point data elements. The data type is determined by the instruction opcode. This instruction also uses source swizzles (`.yxzw` for `src0` and `.zwx` for `src1`) and a destination mask (`.xyz`). Please refer to the programming specifications of 3D graphics API Shader instructions for more details.

A general register has 256 bits, which can store 8 floating point data elements. For 3D graphics, the mode of operation is (loosely) termed after the data structure as $SIMD_{m \times n}$, where m is the size of the vector and n is the number of concurrent program flows executed in SIMD.

Execution with AOS data structures:

- **SIMD4** (short for $SIMD_{4 \times 1}$) indicates that a SIMD instruction operates on 4-element vectors stored in registers. There is one program flow.
- **SIMD4x2** indicates that a SIMD instruction operates on a pair of 4-element vectors in registers. There are effectively two programs running side by side with one vector per program.

Execution with SOA data structures, also referred to as *channel serial* execution, mostly uses:

- **SIMD8** (short for $SIMD_{1 \times 8}$) indicates a SIMD instruction based on the SOA data structure where one register contains one data element (the same one) for each of 8 vectors. Effectively, there are 8 concurrent program flows.
- **SIMD16** (short for $SIMD_{1 \times 16}$) indicates that a SIMD instruction operates on a pair of registers that contain one data element (the same one) for each of 16 vectors. SIMD16 has 16 concurrent program flows.



SIMD4 Mode of Operation

With a register mapping of src0 to doublewords 0-3 of *r2*, src1 to doublewords 4-7 of *r2* and dst to doublewords 0-3 of *r3*, the example 3D graphics API Shader instruction can be translated into the following GEN instruction:

```
add (4) r3<4>.xyz:f r2<4>.yzwx:f r2.4<4>.zwxy:f {NoMask}
```

Without diving too much into the syntax definition of a GEN instruction, it is clear that a GEN instruction also takes two source operands and one destination operands. The second term, (4), is the execution size that determines the number of data elements processed by the SIMD instruction. It is similar to the term SIMD Width used in the literature. Each operand is described by the register region parameters such as <4> and data type (e.g. *.f*). These will be detailed in the SIMD8 Mode of Operation section. The instruction option field, {NoMask}, ensure that the execution occurs for the execution channels shown in the instruction, instead of, possibly, being masked out by the conditional masks of the thread (See Instruction Summary chapter for definition of *MaskCtrl* instruction field).

The operation of this GEN instruction is illustrated in the following figure. In this example, both source operands share the same physical GRF register *r2*. The two are distinguished by the sub-register number. The source swizzles control the routing of source data elements to the parallel adders corresponding to the destination data elements. The shaded areas in the destination register *r3* are not modified. In particular, doublewords 4-7 are unchanged as the execution size is 4; doubleword 3 is unchanged due to the destination mask setting.

In this mode of operation, there is only one program flow – any branch decision will be based on a scalar condition and apply to the whole vector of four elements. Option {NoMask} ensures that the instruction is not subject to the masks. In fact, most of the instructions in a thread should have {NoMask} set.

Even though the execution only performs four parallel add operations, the GEN instruction still executes in 2 cycles (with no useful computation in the second cycle).

A SIMD4 Example

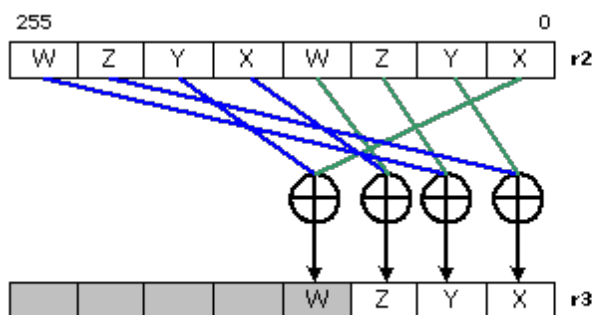

B6891-01



SIMD4x2 Mode of Operation

In this mode, two corresponding vectors from the two program flows fill a GEN register. With a register mapping of src0 to r2, src1 to r3 and dst to r4, the example 3D graphics API Shader instruction can be translated into the following GEN instruction:

```
add (8) r4<4>.xyz:f r2<4>.yxzw:f r3<4>.zwxy:f
```

This instruction is subject to the execution mask, which initiated from the dispatch mask. If both program flows are available (e.g. Vertex Shader executed with two active vertices), the dispatch mask is set to 0x00FF. The operation of this GEN instruction is illustrated in *SIMD4x2 Mode of Operation (a)*. The source swizzles control the routing of source data elements to the parallel adders corresponding to the destination data elements. The shaded areas in the destination register r3 (doublewords 3 and 7) are unchanged due to the destination mask setting. If only one program flow is available (e.g. the same SIMD4x2 Vertex Shader with only one active vertex), the dispatch mask is set to 0x000F. The operation of the same instruction is shown in *SIMD4x2 Mode of Operation (b)*.

SIMD4x2 Examples with Different Emasks

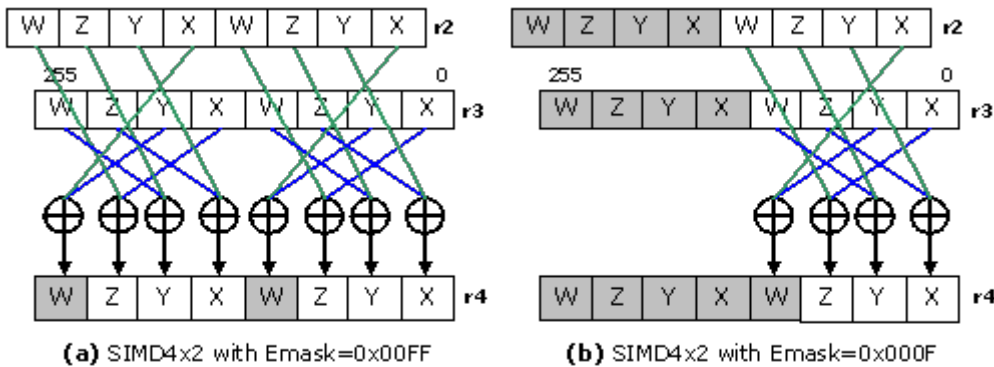

B.6892-01

The two source operands only need to be 16-byte aligned, not have to be GRF register aligned. For example, the first source operand could be a 4-element vector (e.g. a constant) stored in doublewords 0-3 in r2, which is shared by the two program flows. The example 3D graphics API Shader instruction can then be translated into the following GEN instruction:

```
add (8) r4<4>.xyz:f r2<0>.yzwx:f r3<4>.zwxy:f
```

The only difference here is that the vertical stride of the first source is 0. The operation of this GEN instruction is illustrated in *SIMD4x2 Mode of Operation*.

A SIMD4x2 Example with a Constant Vector Shared by Two Program Flows

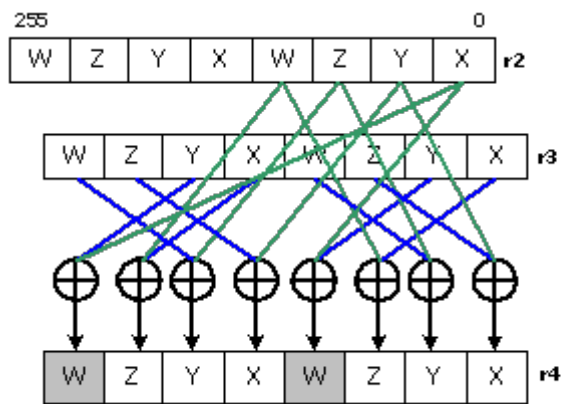

B6893-01



SIMD16 Mode of Operation

With 16 concurrent program flows, one element of a vector would take two GRF registers. In this mode, two corresponding vectors from the two program flows fill a GEN register.

With the following register mappings,

src0:r2-r9 (with 16 X data elements in r2-r3, Y in r4-5, Z in r6-7 and W in r8-9),

src1: r10-r17,

dst:r18-r25,

the example 3D graphics API Shader instruction can be translated into the following three GEN instructions:

```
add (16) r18<1>:f r4<8;8,1>:f r14<8;8,1>:f // dst.x = src0.y + src1.z
```

```
add (16) r20<1>:f r6<8;8,1>:f r16<8;8,1>:f // dst.y = src0.z + src1.w
```

```
add (16) r22<1>:f r8<8;8,1>:f r10<8;8,1>:f // dst.z = src0.w + src1.x
```

The three GEN instructions correspond to the three enabled destination masks. As there is no output for the W elements of *dst*, no instruction is needed for that element. The first instruction inputs the Y elements of *src0* and the Z elements of *src1* and outputs the X elements of *dst*. The operation of this instruction is shown in *SIMD16 Mode of Operation*.

With more than one program flow, the above instructions are also subject to the execution mask. The 16-bit dispatch mask is partitioned into four groups with four bits each. For Pixel Shader generated by the Windower, each 4-bit group corresponds to a 2x2 pixel subspan. If a subspan is not valid for a Pixel Shader instance, the corresponding 4-bit group in the dispatch mask is not set. Therefore, the same instructions can be used independent of the number of available subspans without creating bogus data in the subspans that are not valid.

A SIMD16 Example

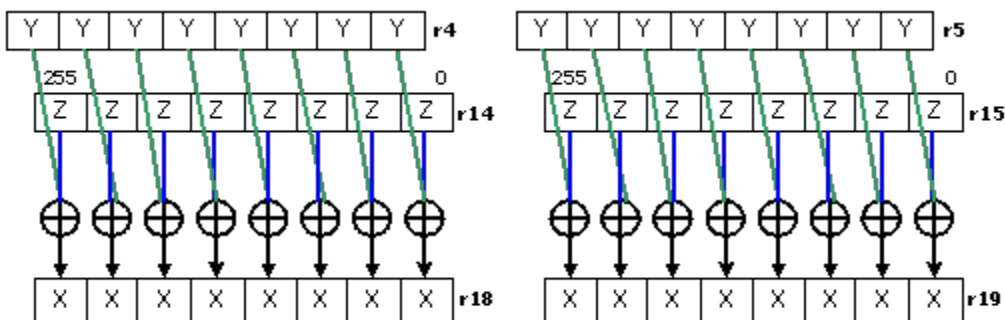

```
Add (16) r18<1>:f r4<8;8,1>:f r14<8;8,1>:f {Compr} // dst.x=src0.y+src1.z
```

B6894-01

Similar to SIMD4x2 mode, a constant may also be shared for the 16 program flows. For example, the first source operand could be a 4-element vector (e.g. a constant) stored in doublewords 0-3 in r2 (AOS



format). The example 3D graphics API Shader instruction can then be translated into the following GEN instruction:

```
add (16) r18<1>:f r2.1<0;1,0>:f r14<8;8,1>:f {Compr} // dst.x = src0.y + src1.z
```

```
add (16) r20<1>:f r2.2<0;1,0>:f r16<8;8,1>:f {Compr} // dst.y = src0.z + src1.w
```

```
add (16) r22<1>:f r2.3<0;1,0>:f r10<8;8,1>:f {Compr} // dst.z = src0.w + src1.x
```

The register region of the first source operand represents a replicated scalar. The operation of the first GEN instruction is illustrated in *SIMD16 Mode of Operation*.

Another SIMD16 Example with an AOS Shared Constant

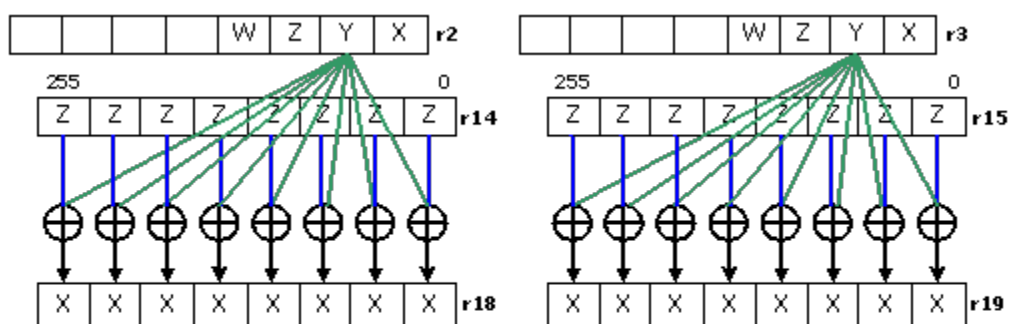

```
Add (16) r18<1>:f r2.1<0;1,0>:f r14<8;8,1>:f {Compr} // dst.x=src0.y+src1.z
```

B6895-01



SIMD8 Mode of Operation

Each compressed instruction has two corresponding native instructions. Taking the example instruction shown in *SIMD16 Mode of Operation*, it is equivalent to the following two instructions.

```
add (8) r18<1>:f r4<8;8,1>:f r14<8;8,1>:f // dst.x[7:0] = src0.y + src1.z
```

```
add (8) r19<1>:f r5<8;8,1>:f r15<8;8,1>:f {SecHalf} // dst.x[15:8] = src0.y + src1.z
```

Therefore, SIMD8 can be viewed as a special case for SIMD16.

There are other reasons that SIMD8 instructions may be used. Within a program with 16 concurrent program flows, some time SIMD8 instruction must be used due to architecture restrictions. For example, the address register a0 only have 8 elements, if an indirect GRF addressing is used, SIMD16 instructions are not allowed.



Message Payload Containing a Header

For most shared functions, the first register of the message payload contains the *header payload* of the message (or simply the *message header*). Consequently, the rest of the message payload is referred to as the *data payload*.

Messages to Extended Math do not have a header and only contain data payload. Those messages may be referred to as header-less messages. Messages to Gateway combine the header and data payloads in a single message register.



Writebacks

Some messages generate return data as dictated by the *function-control* (opcode) field of the *send* instruction (part of the <desc> field). The Gen4 execution unit and message passing infrastructure do not interpret this field in any way to determine if writeback data is to be expected. Instead explicit fields in the *send* instruction to the execution unit the starting GRF register and count of returning data. The execution unit uses this information to set in-flight bits on those registers to prevent execution of any instruction which uses them as an operand until the register(s) is(are) eventually written in response to the message. If a message is not expected to return data, the *send* instruction's writeback destination specifier (<post_dest>) must be set to *null* and the response length field of <desc> must be 0 (see *send* instruction for more details).

The writeback data, if called for, arrives as a series of register writes to the GRF at the location specified by the starting GRF register and length as specified in the *send* instruction. As each register is written back to the GRF, its in-flight flag is cleared and it becomes available for use as an instruction operand. If a thread was suspended pending return of that register, the dependency is lifted and the thread is allowed to continue execution (assuming no other dependency for that thread remains outstanding).



Message Delivery Ordering Rules

All messages between a thread and an individual shared function are delivered in the order they were sent. Messages to different shared functions originating from a single thread may arrive at their respective shared functions out of order.

The writebacks of various messages from the shared functions may return in any order. Further individual destination registers resulting from a single message may return out of order, potentially allowing execution to continue before the entire response has returned (depending on the dependency chain inherent in the thread).



Execution Mask and Messages

The Gen4 Architecture defines an Execution Mask (EMask) for each instruction issued. This 16b bit-field identifies which SIMD computation channels are enabled for that instruction. Since the *send* instruction is inherently scalar, the EMask is ignored as far as instruction dispatch is concerned. Further the execution size has no impact on the size of the *send* instruction's implicit move (it is always 1 register regardless of specified execution size).

The 16b EMask is forwarded with the message to the destination shared function to indicate which SIMD channels were enabled at the time of the *send*. A shared function may interpret or ignore this field as dictated by the functionality it exposes. For instance, the Extended Math shared function observes this field and performs the specified operation only on the operands with enabled channels, while the DataPort writes to the render cache ignore this field completely, instead using the pixel mask included in-band in the message payload to indicate which channels carry valid data.



End-Of-Thread (EOT) Message

The final instruction of all threads must be a *send* instruction that signals *End-Of-Thread* (EOT). An EOT message is one in which the EOT bit is set in the *send* instruction's 32b <desc> field. When issuing instructions, the EU looks for an EOT message, and when issued, shuts down the thread from further execution and considers the thread completed.

Only a subset of the shared functions can be specified as the target function of an EOT message, as shown in the table below.

Target Shared Functions supporting EOT messages	Target Shared Functions <u>not</u> supporting EOT messages
Null, DataPortWrite, URB, MessageGateway, ThreadSpawner	DataPortRead, Sampler

Both the fixed-functions and the thread dispatcher require EOT notification at the completion of each thread. The thread dispatcher and fixed functions in the 3D pipeline obtain EOT notification by snooping all message transmissions, regardless of the explicit destination, looking for messages which signal end-of-thread. The Thread Spawner in the media pipeline does not snoop for EOT. As it is also a shared function, all threads generated by Thread Spawner must send a message to Thread Spawner to explicitly signal end-of-thread.

The thread dispatcher, upon detecting an end-of-thread message, updates its accounting of resource usage by that thread, and is free to issue a new thread to take the place of the ended thread. Fixed functions require end-of-thread notification to maintain accounting as to which threads it issued have completed and which remain outstanding, and their associated resources such as URB handles.

Unlike the thread dispatcher, fixed-functions discriminate end-of-thread messages, only acting upon those from threads which they originated, as indicated by the 4b fixed-function ID present in R0 of end-of-thread message payload. This 4b field is attached to the thread at new-thread dispatch time and is placed in its designated field in the R0 contents delivered to the GRF. Thus to satisfy the inclusion of the fixed-function ID, the typical end-of-thread message generally supplies R0 from the GRF as the first register of an end-of-thread message.

As an optimization, an end-of-thread message may be overload upon another *productive* message, saving the cost in execution and bandwidth of a dedicated end-of-thread message. Outside of the end-of-thread message, most threads issue a message just prior to their termination (for instance, a Dataport write to the framebuffer) so the overloaded end-of-thread is the common case. The requirement is that the message contains R0 from the GRF (to supply the fixed-function ID), and that destination shared function be either (a) the URB; (b) the Read or Write Dataport; or, (c) the Gateway, as these functions reside on the O-Bus. In the case where the last real message of a thread is to some other shared function, the thread must issue a separate message for the purposes of signaling end-of-thread to the *null* shared function.



Message Description Syntax

All message formats are defined in terms of DWords (32 bits). The message registers in all cases are 256 bits wide, or 8 DWords. The registers and DWords within the registers are named as follows, where n is the register number, and d is the DWord number from 0 to 7, from the least significant DWord at bits [31:0] within the 256-bit register to the most significant DWord at bits [255:224], respectively. For writeback messages, the register number indicates the offset from the specified starting destination register.

Dispatch Messages: **R** n . d

Dispatch messages are sent by the fixed functions to dispatch threads. See the fixed function chapters in the *3D and Media* volume.

SEND Instruction Messages: **M** n . d

These are the messages initiated by the thread via the SEND instruction to access shared functions. See the chapters on the shared functions later in this volume.

Writeback Messages: **W** n . d

These messages return data from the shared function to the GRF where it can be accessed by thread that initiated the message.

The bits within each DWord are given in the second column in each table.



Message Errors

Messages are constructed via software, and not all possible bit encodings are legal, thus there is the possibility that a message may be sent containing one or more errors in its descriptor or payload contents. There are two points of error detection in the message passing system: (a) the message delivery subsystem is capable of detecting bad FunctionIDs and some cases of bad message lengths; (b) the shared functions contain various error detection mechanisms which identify bad sub-function codes, bad message lengths, and other misc errors. The error detection capabilities are specific to each shared function. The execution unit hardware itself does not perform message validation prior to transmission.

In both cases, information regarding the erroneous message is captured and made visible through MMIO registers, and the driver notified via an interrupt mechanism . The set of possible errors is listed in *Message Errors* with the associated outcome.

Error Cases

Error	Outcome
Bad Shared Function ID	The message is discarded before reaching any shared function. If the message specified a destination, those registers will be marked as in-flight, and any future usage by the thread of those registers will cause a dependency which will never clear, resulting in a hung thread and eventual time-out.
Unknown opcode Incorrect message length	The destination shared function detects unknown opcodes (as specified in the <i>send</i> instructions <desc> field), and known opcodes where the message payload is either too long or too short, and treats these cases as errors. When detected, the shared function latches and makes available via MMIO registers the following information: the EU and thread ID which sent the message, the length of the message and expected response, and any relevant portions of the first register (R0) of the message payload. The shared function alerts the driver of an erroneous message through an interrupt mechanism, then continues normal operation with the subsequent message.
Bad message contents in payload	Detection of bad data is an implementation decision of the shared function. Not all fields may be checked by the shared function, so an erroneous payload may return bogus data or no data at all. If an erroneous value is detected by the shared function, it is free to discard the message and continue with the subsequent message. If the thread was expecting a response, the destination registers specified in the associated <i>send</i> instruction are never cleared potentially resulting in a hung thread and time-out.
Incorrect response length	Case: too few registers specified – the thread may proceed with execution prior to all the data returning from the shared function, resulting in the thread operating on bad data in the GRF. Case: too many registers specified – the message response does not clear all the registers of the destination. In this case, if the thread references any of the residual registers, it may hang and result in an eventual time-out.
Improper use of End-Of-Thread (EOT)	Any <i>send</i> instruction which specifies EOT must have a <i>null</i> destination register. The EU enforces this and, if detected, will not issue the <i>send</i> instruction, resulting in a hung thread and an eventual time-out. The <i>send</i> instruction specifies that EOT is only recognized if the <desc> field of the



Error	Outcome
	instruction is an immediate. Should a thread attempt to end a thread using a <desc> sourced from a register, the EOT bit will not be recognized. In this case, the thread will continue to execute beyond the intended end of thread, resulting in a wide range of error conditions.
Two outstanding messages using overlapping GRF destinations ranges	This is not checked by HW. Due to varying latencies between two messages, and out-of-order, non-contiguous writeback cycles, the outcome in the GRF is indeterminate; may be the result from the first message, or the result from the second message, or a combination of both.



Registers and Register Regions

Register Files

GEN registers are grouped into different name spaces called register files. There are two register files, the General Register File and the Architecture Register File. A third encoding of some register file instruction fields indicates immediate operands within instructions rather than a register file.

- General Register File (GRF): The GRF contains general-purpose read-write registers.
- Architecture Register File (ARF): The ARF contains all architectural registers defined for specific purposes, including address registers (*a#*), accumulators (*acc#*), flags (*f#*), notification count (*n#*), instruction pointer (*ip*), null register (*null*), etc.
- Immediate: Certain instructions can take immediate source operands. A distinct register file field encoding indicates an immediate operand.

Each thread executed in an EU has its own thread context, a dedicated register space that is not shared between threads, whether executing on a common EU or on a different EU. In the rest of the chapters in this volume, register access is relative to a given thread.



GRF Registers

Number of Registers:Various

Default Value:None

Normal **Access:**RW

Elements:Various

Element **Size:**Various

Element Type:Various

Access Granularity:Byte

Write Mask Granularity:Byte

Indexable?Yes

Registers in the General Register File are the most commonly used read-write registers. During the execution of a thread, GRF registers are used to store the temporary data, and serve as the destination to receive data from shared function units (and some times from a fixed function unit). They are also used to store the input (initialization) data when a thread is created. By allowing fixed function hardware to initialize some portion of GRF registers during thread dispatch time, GEN architecture can achieve better parallelism. A thread's execution efficiency can also be improved as some data are already in the register to be executed upon. Besides these registers containing thread's payload, the rest of GRF registers of a thread are not initialized.

Summary of GRF Registers

Register File	Register Name	Description
General Register File (GRF)	r#	General purpose read write registers

Each execution unit has a fixed size physical GRF register RAM. The GRF register RAM is shared by all threads on the EU. Each thread has a dedicated space of 128 register, r0 through r127.

GRF registers can be accessed using region-based addressing at byte granularity (both read and write). A source operand must be contained within two adjacent registers. A destination operand must be contained within one register. GRF registers support direct addressing and register-indirect addressing. Register-indirect addressing uses the address registers (ARF registers a#) and an immediate address offset value.

When accessing (read and/or write) outside the GRF register range allocated for a given thread either through direct or indirect addressing, the result is unpredictable.



ARF Registers

ARF Registers Overview

Besides GRF registers that are directly indicated by unique register file coding, all other registers belong to the Architecture Register File (ARF). Encodings of architecture register types are based on the MSBs of the register number field, RegNum, in the instruction word. The RegNum field has 8 bits. The 4 MSBs, RegNum[7:4], represent the architecture register type. This is summarized in the following table.

Summary of Architecture Registers

Register Type (RegNum [7:4])	Register Name	Register Count	Description	Project	Security
0000b	<i>null</i>	1	Null register		
0001b	<i>a0.#</i>	1	Address register		
0010b	<i>acc#</i>	2	Accumulator register		
0011b	<i>f#.#</i>	2	Flag register		
0100b	<i>ce#</i>	1	Channel Enable register		
0101b	<i>Reserved</i>		Reserved		
0110b	<i>sp</i>	1	Stack Pointer Register		
0111b	<i>sr0.#</i>	1	State register		
1000b	<i>cr0.#</i>	1	Control register		
1001b	<i>n#</i>	2	Notification Count register		
1010b	<i>ip</i>	1	Instruction Pointer register		
1011b	<i>tdr</i>	1	Thread Dependency register		
1100b	<i>tm0</i>	2	TimeStamp register		
1101b	<i>fc#.#</i>	39	Flow Control register		
1110b	<i>Reserved</i>		Reserved		

The remaining register number field RegNum[3:0] is used to identify the register number of a given architecture register type. Therefore, the maximum number of registers for a given architecture register type is limited to 16. The sub-register number field, SubRegNum, in the instruction word has 5 bits. It is used to address sub-register regions for an architecture register supporting register subdivision. The SubRegNum field is in units of bytes. Therefore, the maximum number of bytes of an architecture register is limited to 32. Depending on the alignment restriction of a register type, only certain encodings of SubRegNum field apply for an architecture register. The detailed definitions are provided in the following sections.

Description	Project
In general an ARF register can be dst (destination) or src0 (source 0, first source)	HSW



Description	Project
operand) for an instruction. Depending on the register and the instruction, other restrictions may apply.	

Access Granularity

ARF registers may be accessed with sub-register granularity according to the descriptions below and following the same rule of region-based addressing for GRF. The machine code for register number and sub-register number of ARF follows the same rule as for other register files with byte granularity. For an ARF as a source operand, the region-based address controls the source swizzle mux. The destination sub-register number and destination horizontal stride can be used to generate the destination write mask at byte level.

Subregister fields of an ARF register may not all be populated (indicated by the sub-register being indicated as reserved). Writes to unpopulated sub-registers are dropped; there are no side effect. Reads from unpopulated sub-registers, if not specified, return unpredictable data.

Some ARF registers are read-only. Writes to read-only ARF registers are dropped and there are no side effects.

Null Register

Null Register Summary

Attribute	Value
ARF Register Type Encoding (RegNum[7:4]):	0000b
Number of Registers:	1
Default Value:	N/A
Normal Access:	N/A
Elements:	N/A
Element Size:	N/A
Element Type:	N/A
Access Granularity:	N/A
Write Mask Granularity:	N/A
SecHalf Control?	N/A
Indexable?	No

The null register is a special encoding for an operand that does not have a physical mapping. It is primarily used in instructions to indicate non-existent operands. Writing to the null register has no side effect. Reading from the null register returns an undefined result.

The null register can be used where a source operand is absent. For example, for a single source operand instruction such as MOV or NOT, the second source operand src1 must be a null register.



When the null register is used as the destination operand of an instruction, it indicates the computed results are not stored in any registers. However, implied writes to the accumulator register, if applicable, may still occur for the instruction. When the conditional modifier is present, updates to the selected flag register also occur. In this case, the register region fields of the *null* operand are valid.

Another example use is to use the null register as the posted destination of a *send* instruction for data write to indicate that no write completion acknowledgement is required. In this case, however, the register region fields are still valid. The null register can also be the first source operand for a *send* instruction indicating the absent of the implied move. See the *send* instruction for details.

Address Register

Address Register Summary

Attribute	Value
ARF Register Type Encoding (RegNum[7:4]):	0001b
Number of Registers:	1
Default Value:	None
Normal Access:	RW
Elements:	8
Element Size:	16 bits
Element Type:	UW or UD
Access Granularity:	Word
Write Mask Granularity:	Word
SecHalf Control?	N/A
Indexable?	No

There are eight address sub-registers forming an 8-element vector. Each address sub-register contains 16 bits. Address sub-registers can be used as regular source and destination operands, as the indexing addresses for register-indirect-addressed access of GRF registers, and also as the source of the message descriptor for the *send* instruction.

Register and Subregister Numbers for Address Register

RegNum[3:0]	SubRegNum[4:0]
0000b = a0 All other encodings are reserved.	When register a0 or sub-registers in a0 are used as the address register for register-indirect addressing, the address sub-registers must be accessed as unsigned word integers. Therefore, the sub-register number field must also be word-aligned. 00000b = a0.0:uw 00010b = a0.1:uw 00100b = a0.2:uw



RegNum[3:0]	SubRegNum[4:0]
	00110b = a0.3:uw 01000b = a0.4:uw 01010b = a0.5:uw 01100b = a0.6:uw 01110b = a0.7:uw All other encodings are reserved. However, when register a0 or sub-registers in a0 are explicit source and/or destination registers, other data types are allowed as long as the register region falls in the 128-bit range.

Address Register Fields

DWord	Bits	Description
7	31:16	Address sub-register a0.15:uw. Follows the same format as a0.3 .
	15:0	Address sub-register a0.14:uw. Follows the same format as a0.2 .
6	31:16	Address sub-register a0.13:uw. Follows the same format as a0.3 .
	15:0	Address sub-register a0.12:uw. Follows the same format as a0.2 .
5	31:16	Address sub-register a0.11:uw. Follows the same format as a0.3 .
	15:0	Address sub-register a0.10:uw. Follows the same format as a0.2 .
4	31:16	Address sub-register a0.9:uw. Follows the same format as a0.3 .
	15:0	Address sub-register a0.8:uw. Follows the same format as a0.2 .
3	31:16	Address sub-register a0.7:uw. Follows the same format as a0.3 .
	15:0	Address sub-register a0.6:uw. Follows the same format as a0.2 .
2	31:16	Address sub-register a0.5:uw. Follows the same format as a0.3.
	15:0	Address sub-register a0.4:uw. Follows the same format as a0.2.
1	31:16	Address sub-register a0.3:uw. This field, with only the lower 12 bits populated can be used as an unsigned integer for register-indirect register addressing. Format: U12
	15:0	Address sub-register a0.2:uw. This field, with only the lower 12 bits populated can be used as an unsigned integer for register-indirect register addressing. Format: U12
0	31:16	Address sub-register a0.1:uw. This field can be used for register-indirect register addressing or



DWord	Bits	Description
		serve as message descriptor for a <i>send</i> instruction. When used for register-indirect register addressing, it is a 12-bit unsigned integer. For a <i>send</i> instruction, it provides the higher 16 bits of <desc>. Format: U12 or U16.
	15:0	Address sub-register a0.0:uw. This field can be used for register-indirect register addressing or serve as message descriptor for a <i>send</i> instruction. When used for register-indirect register addressing, it is a 12-bit unsigned integer. For a <i>send</i> instruction, it provides the lower 16 bits of <desc>. Format: U12 or U16.

When used as a source or destination operand, the address sub-registers can be accessed individually or as a group. In the following example, the first instruction moves 8 address sub-registers to the first half of GRF register r1, the second instruction replicates a0.4:uw as an unsigned word to the second half of r1, the third instruction moves the first 4 words in r1 into the first 4 address sub-registers, and the fourth instruction replicates r1.4 as a unsigned word to the next 4 address sub-registers.

```
mov (8) r1.0<1>:uw a0.0<8;8,1>:uw // r1.n = a0.n for n = 0 to 7 in words
mov (8) r1.8<1>:uw a0.4<0;1,0>:uw // r1.m = a0.4 for m = 8 to 15 in words
mov (4) a0.0<1>:uw r1.0<4;4,1>:uw // a0.n = r1.n for n = 0 to 3 in words
mov (4) a0.4<1>:uw r1.4<0;1,0>:uw // a0.m = r1.4 for m = 4 to 7 in words
```

When used as the register-indirect addressing for GRF registers, the address sub-registers can be accessed individually or as a group. When accessed as a group, the address sub-registers must be group-aligned. For example, when two address sub-registers are used for register indirect addressing, they must be aligned to even address sub-registers. In the following example, the first instruction is legal. However, the second one is not. As ExecSize = 8 and the width of src0 is 4, two address sub-registers are used as row indices, each pointing to 4 data elements spaced by HorzStride = 1 dword. For the first instruction, the two address sub-registers are a0.2:uw and a0.3:uw. The two align to a DWord group in the address register. However, the two address sub-registers for the second instruction are a0.3:uw and a0.4:uw. They are not DWord-aligned in the address register and therefore violate the above mentioned alignment rule.

```
mov (8) r1.0<1>:d r[a0.2]<4,1>:d // a0.2 and a0.3 are used for src1
mov (8) r1.0<1>:d r[a0.3]<4,1>:d // ILLEGAL use of register indirect
```

Implementation restriction: GEN ISA supports per channel indexing for a source operand. As there are only 8 sub-fields in the address register (to save hardware cost), the execution size of an instruction using per-channel indexing is limited to 8. Software may reload the address register and use compression control SecHalf to complete a 16-channel computation.

Implementation restriction: When used as the source operand <desc> for the send instruction, only the first dword sub-register of a0 register is allowed (i.e. a0.0:ud, which can be viewed as the combination of a0.0:uw and a0.1:uw). In addition, it must be of UD type and in the following form <desc> = a0.0<0;1,0>:ud.



Performance Note: There is only one scoreboard for the whole address register. When a write to some sub-registers is in flight, hardware stalls any instruction writing to other sub-registers. Software may use the destination dependency control {NoDDChk, NoDDClr} to improve performance in this case. Similarly, when a write to some sub-registers is in flight, hardware stalls any instruction sourcing other sub-registers until the write retires.

Accumulator Registers

Accumulator Registers Summary

Attribute	Value	Project
ARF Register Type Encoding (RegNum[7:4]):	0010b	All
Number of Registers:	2	HSW
Default Value:	None	All
Normal Access:	RW	All

Accumulator registers can be accessed either as explicit or implied source and/or destination registers. To a programmer, each accumulator register may contain either 8 DWords or 16 Words of data elements. However, as described in the Implementation Precision Restriction notes below, each data element may have higher precision with added guard bits not indicated by the numeric data type.

Accumulator capabilities vary by data type, not just data size, as described in the Accumulator Channel Precision table below. For example, D and F are both 32-bit data types, but differ in accumulator support.

See the [Accumulator Restrictions](#) section for information about additional general accumulator restrictions and also accumulator restrictions for specific instructions.

Accumulator Registers	Project
There are two accumulator registers, acc0 and acc1.	HSW

Register and Subregister Numbers for Accumulator Registers

RegNum[3:0]	SubRegNum[4:0]	Project
0000b = acc0 0001b = acc1 All other encodings are reserved	Reserved: MBZ	HSW

- Accumulators are updated implicitly only if the AccWrCtrl bit is set in the instruction. The Accumulator Disable bit in control register cr0.0 allows software to disable the use of AccWrCtrl for implicit accumulator updates. The write enable in word granularity for the instruction is used to update the accumulator. Data in disabled channels is not updated.
- When an accumulator register is an implicit source or destination operand, hardware always uses acc0 by default and also uses acc1 if the execution size exceeds the number of elements in acc0. When implicit access to acc1 is required, QtrCtrl is used. Note that QtrCtrl can be used only if acc1



is accessible for a given data type. If acc1 is not accessible for a given data type, QtrCtrl defaults to acc0.

	Project
acc0 and acc1 are supported for single-precision Float (F) only. Use QtrCtrl of Q2 or Q4 to access acc1.	HSW

Examples:

```
// Updates acc0 and acc1 because it is SIMD16:
add (16) r10:f r11:f r12:f {AccWrEn}
// Updates acc0 because it is SIMD8:
add (8) r10:f r11:f r12:f {AccWrEn}
// Updates acc1. Implicit access to acc1 using QtrCtrl:
add (8) r10:f r11:f r12:f {AccWrEn, Q2}
// Updates acc1 for Half Floats using QtrCtrl:
add (16) r10:hf r11:hf r12:hf {AccWrEn, H2}
```

- It is illegal to specify different accumulator registers for source and destination operands in an instruction (e.g. "*add (8) acc1:f acc0:f*"). The result of such an instruction is unpredictable.
- Swizzling is not allowed when an accumulator is used as an implicit source or an explicit source in an instruction.
- Reading accumulator content with a datatype different from the previous write will result in undeterministic values.
- For any DWord operation, including DWord multiply, accumulator can store up to 8 channels of data, with only acc0 supported.
- When an accumulator register is an explicit destination, it follows the rules of a destination register. If an accumulator is an explicit source operand, its register region must match that of the destination register with the exception(s) described below.

Implementation Precision Restriction: As there are only 64 bits per channel in DWord mode (D and UD), it is sufficient to store the multiplication result of two DWord operands as long as the post source modified sources are still within 32 bits. If any one source is type UD and is negated, the negated result becomes 33 bits. The DWord multiplication result is then 65 bits, bigger than the storage capacity of accumulators. Consequently, the results are unpredictable.

Implementation Precision Restriction: As there are only 33 bits per channel in Word mode (W and UW), it is sufficient to store the multiplication result of two Word operands with and without source modifier as the result is up to 33 bits. Integers are stored in accumulator in 2's complement form with bit 32 as the sign bit. As there is no guard bit left, the accumulator can only be sourced once before running into a risk of overflowing. When overflow occurs, only modular addition can generate a correct result. But in this case, conditional flags may be incorrect. When saturation is used, the output is unpredictable. This is also true for other operations that may result in more than 33 bits of data. For example, adding UD (FFFFFFFFh) with D (FFFFFFFFh) results in 1FFFFFFFFeh. The sign bit is now at bit 34 and is lost when stored in the accumulator. When it is read out later from the accumulator, it becomes a negative number as bit 32 now becomes the sign bit.



Accumulator Channel Precision

Project	Data Type	Accumulator Number	Number of Channels	Bits Per Channel	Description
All	DF	acc0	4	64	When accumulator is used for Double Float, it has the exact same precision as any GRF register.
HSW	F	acc0/acc1	8	32	When accumulator is used for Float, it has the exact same precision as any GRF register.
	Q	N/A	N/A	N/A	Not supported data type.
	D (UD)	acc0	8	33/64	When the internal execution data type is doubleword integer, each accumulator register contains 8 channels of (extended) doubleword integer values. The data are always stored in accumulator in 2's complement form with 64 bits total regardless of the source data type. This is sufficient to construct the 64-bit D or UD multiplication results using an instruction macro sequence consisting of <i>mul</i> , <i>mach</i> , and <i>shr</i> (or <i>mov</i>).
	W (UW)	acc0	16	33	When the internal execution data type is word integer, each accumulator register contains 16 channels of (extended) word integer values. The data are always stored in accumulator in 2's complement form with 33 bits total. This supports single instruction multiplication of two word sources in W and/or UW format.
	B (UB)	N/A	N/A	N/A	Not supported data type.

These are accumulator registers defined for a special purpose. They are used to emulate IEEE-compliant *fddiv* and *sqrt* macro operations. The access is different from *acc0* and *acc1*. Each of these accumulator registers are defined as 256-bit registers having 8 DWords. These may be accessed explicitly or implicitly.

- These registers may be accessed explicitly only by a *mov* operation, with no source modifiers, condition modifiers or saturation. When accessed explicitly, the datatype must be D. On reads, the low 2 bits of each DWord is valid data. The other bits are undefined. On writes, the low two bits are updated and other bits are dropped.

Example:

```
// Move 256 bits from acc2 to r10. Just low two bits of each DWord are valid:
mov (8) r10:ud acc2:ud

// Move 256 bits from r10 to acc2. Just low two bits of each DWord are updated:
```



```
mov (8) acc2:ud r10:ud
```

- These registers are accessed implicitly by three opcodes defined for the macro operations. **Note:** These macro operations are defined under the *math* opcode section. The macro descriptions also define the restrictive implicit uses of these registers.
- Implicit access across accumulator registers is required for each source operand for these macro instructions. These opcodes are accessed in Align16 mode only. The Channel Select bits in the instruction are used to implicitly address the different accumulators for each source. Similarly the Channel Enable bits are used to implicitly address the accumulators for destination. The noacc value is specified when no write to accumulator is required; think of it as a null.

Channel Select/Channel Enable Encoding for Implicit Source/Destination Access

Flag Register

Flag Register Summary

Attribute	Value
ARF Register Type Encoding (RegNum[7:4]):	0011b
Number of Registers:	[HSW]: 2
Default Value:	None
Normal Access:	RW
Elements:	[HSW]: 2
Element Size:	32 bits
Element Type:	UD
Access Granularity:	Word
Write Mask Granularity:	Word
SecHalf Control?	Yes
Indexable?	No

There are two flag registers, f0 and f1.

Each flag register contains two 16-bit sub-registers. Each flag bit corresponds to a data channel. Predication uses flag values to enable or disable channels. Conditional modifiers assign flag values. If an instruction uses both predication and conditional modifiers, both features use the same flag register or sub-registers.

Flags can be split to halves, quarters, or eighths using the QtrCtrl and NibCtrl instruction fields. Those fields affect the selection of flags for predication and conditional modifiers, but do not affect reading or writing flags as explicit instruction operands.

The values held in the individual bits of a flag register are the result of the most recent instruction with a conditional modifier and specifying that flag register. For example:



add.nz.f0.0 . . .

Updates flag sub-register f0.0 with the per-channel results of the not zero condition.

The flag register has per-bit write enables. When being updated as the secondary destination associated with a conditional modifier, only the bits corresponding to the enabled channels in *EMask* are updated. Other bits in the flag sub-register are unchanged.

Flag registers and sub-registers can also be explicit source or destination operands.

The *sel* instruction does not update flags.

Note: When branching instructions are predicated, branching is evaluated on all channels enabled at dispatch. This means, the appropriate number of flag register bits must be initialized or used in predication depending on the execution mask (*EMask*). Uninitialized flags may result in undesired branching. For example, if using *DMask* as *EMask* and if all 32 channels of *DMask* are enabled, a SIMD8 kernel must initialize unused flag bits so that predication on branching is evaluated correctly.

Register and Subregister Numbers for Flag Register

RegNum[3:0]	SubRegNum[4:0]
0000b = f0:ud	00000b = fn.0:uw
0001b = f1:ud	00010b = fn.1:uw
Other encodings are reserved.	Other encodings are reserved.

Reference an entire flag register as f0:ud or f1:ud. Reference the flag sub-registers as f0.0:uw, f0.1:uw, f1.0:uw, and f1.1:uw.

Channel Enable Register

Channel Enable Register Summary

Attribute	Value
ARF Register Type Encoding (RegNum[7:4]):	0100b
Number of Registers:	1
Default Value:	N/A
Normal Access:	RO
Elements:	1
Element Size:	32 bits
Element Type:	UD
Access Granularity:	DWord
Write Mask Granularity:	N/A
SecHalf Control?	No
Indexable?	No



Register and Subregister Numbers for Channel Enable Register

RegNum[3:0]	SubRegNum[4:0]
0000b = ce	00000b = ce:ud .
All other encodings are reserved.	All other encodings are reserved.

Channel Enable Register Fields

DWord	Bits	Description
0	31:0	Channel Enable Register ce0.0:ud Format: U32 This field contains 32 bits of Channel Enables or the Execution Mask for the current instruction.

SP Register

SP Register Summary

Attribute	Value
ARF Register Type Encoding (RegNum[7:4]):	0110b
Number of Registers:	1
Default Value:	Provided by the Dispatcher
Normal Access:	RW
Elements:	2
Element Size:	32 bits
Element Type:	UD
Access Granularity:	DWord
Write Mask Granularity:	DWord
SecHalf Control	No
Indexable	No

The SP register can be accessed as a unsigned DWord integer. It is a read-write register, containing the current stack pointer, which is relative to the Generate State Base Address. The stack pointer is inserted into the message header when data is stored into scratch space as a stack. The stack pointer is managed by software. If the stack pointer exceeds the limit or the space allocated, an exception is triggered. See the Stack Pointer Exception in the Exceptions Section.

Register and Subregister Numbers for SP Register



RegNum[3:0]	SubRegNum[4:0]
0000b = sp All other encodings are reserved.	00000b = sp:ud . 00100b = sp_limit:ud All other encodings are reserved.

SP Register Fields

DWord	Bits	Description
0	31:0	sp . Specifies the current stack pointer. This pointer is relative to the General State Base Address. This register is initialized at thread load to the top of the per thread Scratch Space. The register is R/W. $sp = [scratch\ space\ pointer] + [scratch\ space] - 1$
1	31:0	sp limit . Specifies the upper limit for the stack pointer. This pointer is relative to the General State Base Address. This register is initialized at thread load to the limit allocated for stack in the state. See the GPGPU Thread Payload description for details. The register is RO. $sp_limit = [scratch\ space\ pointer] + [stack\ space\ limit]$

State Register

State Register Summary

Attribute	Value
ARF Register Type Encoding (RegNum[7:4]):	0111b
Number of Registers:	2
Default Value:	Provided by the Dispatcher
Normal Access:	RW
Elements:	4
Element Size:	32 bits
Element Type:	UD
Access Granularity:	Byte
Write Mask Granularity:	N/A
SecHalf Control?	No
Indexable?	No



Register and Subregister Numbers for State Register

RegNum[3:0]	SubRegNum[4:0]
0000b = sr0	Valid encoding range:
All other encodings are reserved.	00000b – 01100b
	All other encodings are reserved.

State Register Fields

DWord	Bits	Description
0 (sr0.0:ud)	31:28	Reserved. MBZ.
	27:24	FFID (Fixed Function Identifier). Specifies which fixed function unit generates the current thread. This field is set at thread dispatch and is forwarded on the message bus for all out-going messages from this thread.
	23	Priority Class. This field, when set, indicates the thread belongs to the high priority class, which has higher scheduling priority over any thread with this field cleared. The priority field below determines the relative priority within the same priority class. This field is initialized by the thread dispatcher at thread dispatch time and stays unchanged throughout the life span of the thread. This field is forwarded on the message bus to the message bus arbiter for all out-going messages. It serves as a priority hint for the target shared function. See the Shared Function chapters for whether and how a shared function uses this priority hint. 0 = Low priority class. 1 = High priority class.
	22:19	Reserved. MBZ.
	18:16	Priority. This field is the relative aging priority of the thread. This field indicates the 'age' of this thread relative to other threads within the EU. No two threads in the same EU can have the same priority number (independent of the priority class value). Within the same priority class, an older thread (with a larger priority number) has higher schedule priority over a younger thread. This field is set to zero at a thread's dispatch. During a thread's run time, this field may or may not be incremented when a new thread is dispatched to the same EU. It is only incremented when another thread's priority number is incremented and reaches the same value. For example, if currently there is a thread with priority 0 on an EU, then dispatching a new thread to that EU causes the old thread's priority number to increment to 1. However, if the active thread (assuming for simplicity that there is only one) on an EU has a priority number 1 (or 2 or 3), then dispatching a new thread to this EU does not change the old thread's priority number. As threads on an EU may terminate in arbitrary order, the exact number for a thread depends on the dynamic execution of threads.
	15:8	[15] Reserved. MBZ.



DWord	Bits	Description
		[14:13] Slice ID. [12] HSID. HalfSlice Identifier. [11:8] EUID[3:0].
	7:3	Reserved. MBZ.
	2:0	TID (The thread identifier). Specifies the thread slot that the current thread is assigned to. This field is set at thread dispatch.
1 (sr0.1:ud)	31:23	FFTID (Fixed Function Thread ID). [HSW] There is no connection between this thread ID, assigned in fixed functions, and the TID assigned in the EUs.
	22:12	Reserved. MBZ.
	11:8	SLM Offset SLM Offset used by the thread. These bits are Write Only through SW and an attempt to read will result in unpredictable results. If SLM offset is used, then these bits have to be updated at the start of the thread itself.
	7:0	Reserved. MBZ.
	22	Reserved.
2 (sr0.2:ud)	31:0	Dispatch Mask (DMask). This 32-bit field specifies which channels are active at Dispatch time. This field is used by hardware to initialize the mask register. Format: U32
3 (sr0.3:ud)	31:0	Vector Mask (VMask). This 32-bit field contains, for each 4-bit group, the OR of the corresponding 4-bit group in the dispatch mask. This field is used by hardware to initialize the mask register. Format: U32
0 (sr1.0:ud)	31:0	Hardware Defined State Register. The contents of these register are hardware defined and are required only for handling page-fault. These bits are saved and restored by SIP when threads are pre-empted. Writes to these registers must follow the sequence described in 'send' instruction for the correct behavior of hardware.
1 (sr1.1:ud)	31:0	Hardware Defined State Register. Same as sr1.0
2 (sr1.2:ud)	31:0	Hardware Defined State Register. Same as sr1.0
3 (sr1.3:ud)	31:0	Hardware Defined State Register. Same as sr1.0



Control Register

Control Register Summary

Attribute	Value
ARF Register Type Encoding (RegNum[7:4]):	1000b
Number of Registers:	1
Default Value:	Provided by the Dispatcher
Normal Access:	RW
Elements:	4
Element Size:	32 bits
Element Type:	UD
Access Granularity:	DWord
Write Mask Granularity:	DWord
SecHalf Control?	No
Indexable?	No

The Control register is a read-write register. It contains four 32-bit sub-registers that can be accessed individually.

Subregister *cr0.0:ud* contains normal operation control fields such as the floating-point mode and the accumulator disable. It also contains the master exception status/control field that allows software to switch back to the application thread from the System Routine.

Subregister *cr0.1:ud* contains the mask and status/control fields for all exceptions. The exception fields are arranged in significance-decreasing order from MSB to LSB. This arrangement allows the System Routine to use the *lzd* instruction to find the high priority exceptions and handle them first. As each exception is mapped to a single bit, another exception priority order may be implemented by software. The System Routine may choose to handle one exception at a time, by handling the exception detected by an *lzd* instruction and returning to the application thread. Or it may choose to handle all the concurrent exceptions, by looping through the exception fields until all outstanding exceptions are handled before returning back to the application thread.

Exception enable bits (bits 15:0 in *cr0.1:ud*) control whether an exception causes hardware to jump to the System Routine or not. Exception status and control bits (bits 31:16 in *cr0.1:ud*) indicate which exceptions have occurred, and are used by the system routine to clear the exception. Even if a given exception is disabled, the corresponding exception status and control bit still reflects its status, whether an exception event has occurred or not.

cr0.2:ud contains the **Application IP (AIP)** indicating the current thread IP when an exception occurs.

cr0.3:ud is reserved. Values written to this sub-register are dropped; the result of reading from this sub-register is unpredictable.

Fields in Control registers also reference a virtual register called **System IP (SIP)**. SIP is the virtual register holding the global System IP, which is the initial instruction pointer for the System Routine. There is only



one SIP for the whole system. It is virtual only from a thread's point of view, as it is not visible (i.e. not readable and not writeable) to the thread software executed on a GEN EU. It can only be accessed indirectly by the hardware to respond to exception events. Upon an exception, hardware performs some bookkeeping (e.g. saving the current IP into AIP) and then jumps to SIP. Upon finishing exception handling, the System Routine may return back to the application by clearing the Master Exception Status and Control field in *cr0*, which causes the hardware to load AIP to IP register. See the STATE_SIP command for how to set SIP.

Register and Subregister Numbers for Control Register

RegNum[3:0]	SubRegNum[4:0]
0000b = cr0	00000b = cr0.0:ud . It contains general thread control fields.
All other encodings are reserved.	00100b = cr0.1:ud . It contains exception status and control.
	01000b = cr0.2:ud . It contains AIP.
	All other encodings are reserved.

Control Register Fields

DWord	Bits	Description
0	31	<p>Master Exception State and Control. This bit is the master state and control for all exceptions. Reading a 0 indicates that the thread is in normal operation state and a 1 means the thread is in exception handle state. Upon an exception event, hardware sets this bit to 1 and switches to SIP. Writing 1 to this bit has no effect. Writing 0 to this bit also has no effect if the previous value is 0. In both cases, the bit keeps the previous value. If the previous value of this bit is 1, software writing a 0 causes the thread to return to AIP. This transition is automatic – software does not have to move AIP to IP. The value of this bit then stays as 0. This bit is initialized to 0.</p> <p>0 = The thread is in normal state. 1 = The thread is in exception state.</p>
	30:16	Reserved. MBZ.
	15	<p>Breakpoint Suppress. This bit specifies whether breakpoint exception is suppressed or not. This bit is normally set by software and cleared by hardware. If Master Exception Status and Control bit is 1, this bit is ignored by hardware. If Master Exception Status and Control bit is 0 (i.e. not in System Routine) and Breakpoint is enabled: If this bit is set, breakpoint is temporally ignored (suppressed); Upon a breakpoint condition, the instruction is executed and this bit is automatically reset by hardware.</p> <p>This bit is provided to prevent infinite loops of jumping to the System Routine on a breakpoint condition. The System Routine must set this bit (and also clear the corresponding status and control bit) before returning to the application thread.</p> <p>This bit has no effect when Breakpoint Enable bits are cleared. This bit is initialized to 0.</p> <p>0 = Breakpoint exception is not suppressed.</p>



DWord	Bits	Description
		1 = Breakpoint exception is suppressed.
	14:11	Reserved. MBZ.
	10	Reserved.
	9	Reserved.
	7	Reserved.
	6	[HSW]: Double Precision Denorm Mode. This bit determines how denormal numbers are handled for the DF (Double Float) type. It is initialized by Thread Dispatch. 0 = Flush denorms to zero when reading source operands and flush denorm calculation results to zero. Denorm flushing preserves sign. 1 = Allow denorm source values and denorm results.
	5:4	[HSW]: Rounding Mode. This field specifies the FPU rounding mode. It is initialized by Thread Dispatch. 00b = Round to Nearest or Even (RTNE) 01b = Round Up, toward +inf (RU) 10b = Round Down, toward -inf (RD) 11b = Round Toward Zero (RTZ)
	3	Vector Mask Enable (VME). This bit indicates DMask or Vmask should be used by EU for execution. This bit is set by the Thread Dispatch. 0: Use Dispatch Mask (DMASK) 1: Use Vector Mask (VMASK)
	2	Single Program Flow (SPF). Specifies whether the thread has a single program flow (SIMDn _{xm} with m = 1) or multiple program flows (SIMDn _{xm} with m > 1). This bit affects the operation of all branch instructions. In Single Program Flow mode, all execution channels branch and/or loop identically. This bit is initialized by the Thread Dispatch. 0: Multiple Program Flows 1: Single Program Flow Programming Restrictions: Only H1/Q1/N1 are allowed in SPF mode. Power Optimization: If an entire shader does not do SIMD branching, the driver can set the SPF bit to 1 to save power in HW.
	1	Accumulator Disable. This bit controls the update of the accumulator by the instruction field AccWrCtrl. If this bit is cleared, the accumulator is updated for all instructions with AccWrCtrl enabled. If set, the accumulator is disabled for all update operations, maintaining its value prior to



DWord	Bits	Description
		<p>being disabled. Setting this bit has no effect if the accumulator is the explicit destination operand for an instruction. This bit is initialized to 0.</p> <p>0: Enable accumulator update. 1: Disable accumulator update.</p> <p>Usage Notes:</p> <p>This control bit is primarily designed for the System Routine. That routine is not expected to use the accumulator, though it may need to use instructions that implicitly update the accumulator. To use such instructions in the System Routine, but still preserve the accumulator contents on returning to the application kernel, the System Routine would either (a) save and restore the accumulator, or (b) prevent the accumulator from being unintentionally modified. This control bit has been added for the latter method.</p> <p>Software has the option to limit the setting of this control bit to strictly within the System Routine. If, by convention, this bit is clear within application kernels, the System Routine can simply set the bit upon entry and clear it before returning control to the application kernel. This usage model would not necessarily require cr0.0 to be saved/ restored in the System Routine. However, if by convention application kernels are permitted to set this bit, then the System Routine is required to preserve the content of this bit.</p>
	0	<p>Single Precision Floating Point Mode (FP Mode). This bit specifies whether the current single-precision floating-point operation mode is IEEE mode (IEEE Standard 754) or the ALT (alternative mode). This bit does not affect the floating-point mode used for other floating-point data types. This bit is also forwarded on the message sideband for all out-going messages, for example, to control the floating-point mode of the Sampler. Software may modify this bit to dynamically switch between the two floating-point modes. This bit is initialized by Thread Dispatch.</p> <p>0 = IEEE floating-point mode for the F (Float) type. 1 = ALT (alternative) floating-point mode for the F (Float) type.</p>
	30	<p>External Halt Exception Status and Control. This bit indicates the External Halt exception. It is set by EU hardware on receiving the broadcast External Halt signal. The System Routine should reset this bit before returning to an application routine to avoid infinite loops.</p> <p>This bit may be set or cleared by software. This bit is initialized to 0.</p>
	29	<p>Software Exception Control. This bit is the control bit for software exceptions. Setting this bit to 1 in an application routine causes an exception. Clearing this bit in an application routine has no effect. Upon entering the system routine, the hardware maintains this bit as 1 to signify a software exception. The System Routine should reset this bit before returning to an application routine.</p> <p>This bit may be set or cleared by software. This bit is initialized to 0.</p>
	28	<p>Illegal Opcode Exception Status. This bit, when set, indicates an illegal opcode exception. The exception handler routine normally does not return back to the application thread upon an illegal opcode exception. Leaving this bit set has no effect on hardware; if system software adversely returns to an application routine leaving this bit set, it doesn't cause any exception. This bit should</p>



DWord	Bits	Description
		not be set by software or left set by the system routine to avoid confusion. This bit is initialized to 0.
	27	Stack Overflow Exception Status. This bit when set, indicates a stack overflow exception. The exception handler routine normally does not return back to the application thread upon a stack overflow exception. Leaving this bit set has no effect on hardware; if system software adversely returns to an application routine leaving this bit set, it doesn't cause any exception. This bit should not be set by software or left set by the system routine to avoid confusion. This bit is initialized to 0.
	26	Force Exception Status and Control. This bit when set, indicates a Forced Exception. It is set when force exception on receiving the broadcast Force Exception Halt. This is enabled in TD_CTL (Refer to Debug Chapter). The System Routine should reset this bit before returning to an application routine. This bit is initialized to 0.
	25	Context Save Status. This bit when set, indicates a Context Save process has been initiated. The system routine must reset this bit after saving the context to terminate the thread.
	24	Context Restore Status. This bit when set, indicates a Context Restore process has been initiated. The system routine must reset this bit after restoring the context. The reset of this bit is required before invoking application routine.
	23:16	Reserved. MBZ.
	15	Breakpoint Enable. Specifies whether the breakpoint exception is enabled or not. This bit is initialized by the Thread Dispatcher. Format = ENABLED: 0: Disabled 1: Enabled
	13	Software Exception Enable. This bit enables or disables the software exception. Enabling or disabling this bit may allow host software to turn on/off certain features (such as profiling) without changing the kernel program. This bit is initialized by the Thread Dispatcher. Format = ENABLED: 0: Disabled 1: Enabled
	12	Illegal Opcode Exception Enable. This bit specifies whether the illegal opcode exception is enabled or not. The Illegal opcode exception includes illegal opcodes and undefined opcodes, caused by bad programs or run-time data corruption. This bit is initialized by the Thread Dispatcher. Software should normally assign this bit in the interface descriptor. Even though this mechanism is provided to disable the illegal opcode exception, it should be used with extreme caution.



DWord	Bits	Description										
		Format = ENABLED: 0: Disabled 1: Enabled										
	11	<p>Stack Overflow Exception Enable. This bit specifies whether the stack overflow exception is enabled or not. The stack overflow exception includes an overflow or an underflow in the stack space allocated for the thread.</p> <p>This bit is initialized by the Thread Dispatcher.</p> <p>Software should normally assign this bit in the interface descriptor.</p> <p>Format = ENABLED: 0: Disabled 1: Enabled</p>										
	10:0	Reserved. MBZ.										
2 (cr0.2:ud)	31:3	<p>Application IP (AIP). This is the register storing the instruction pointer before an exception is handled. Upon an exception, hardware automatically saves the current IP into the AIP register, and then sets the Master Exception State and Control field to 1, which forces a switch to the System IP (SIP). The AIP register may contain either the pointer to the instruction that causes the exception or the one after (such as masked stack overflow/underflow exceptions). This is shown in the following table, where IP is the instruction that generated the exception.</p> <table border="1" data-bbox="344 1163 1471 1392"> <thead> <tr> <th>Exception Type</th> <th>AIP Value</th> </tr> </thead> <tbody> <tr> <td>Breakpoint</td> <td>IP</td> </tr> <tr> <td>External Halt</td> <td>N/A ⁽¹⁾</td> </tr> <tr> <td>Software Exception</td> <td>IP + 1</td> </tr> <tr> <td>Illegal Opcode</td> <td>IP</td> </tr> </tbody> </table> <p>(1) External Halt exception is asynchronous and not associated with an instruction.</p> <p>When the System Routine changes the Master Exception State and Control field from 1 to 0, hardware restores IP from this register. This field is writable allowing the returning IP to be altered after an exception is handled.</p>	Exception Type	AIP Value	Breakpoint	IP	External Halt	N/A ⁽¹⁾	Software Exception	IP + 1	Illegal Opcode	IP
Exception Type	AIP Value											
Breakpoint	IP											
External Halt	N/A ⁽¹⁾											
Software Exception	IP + 1											
Illegal Opcode	IP											
	2:0	Reserved. MBZ.										

Implementation Restriction on Register Access:When the control register is used as an explicit source and/or destination, hardware does not ensure execution pipeline coherency. Software must set the thread control field to *switch* for an instruction that uses control register as an explicit operand. This is important as the control register is an implicit source for most instructions. For example, fields like FPMODE and Accumulator Disable control the arithmetic and/or logic instructions. Therefore, if the



instruction updating the control register doesn't set *switch*, subsequent instructions may have undefined results.

Notification Registers

Notification Registers Summary

Attribute	Value
ARF Register Type Encoding (RegNum[7:4]):	1001b
Number of Registers:	3
Default Value:	No
Normal Access:	RO (RW – Context save/restore only)
Elements:	3
Element Size:	32 bits
Element Type:	UD
Access Granularity:	DWord
Write Mask Granularity:	DWord
SecHalf Control?	No
Indexable?	No

There are three notification registers (*n0.0:ud*, *n0.1:ud*, and *n0.2:ud*) used by the *wait* instruction. These registers are read-only, except under context restore, and can be accessed in 32-bit granularity. Write access to this register is allowed only when context is restored.

Note: The sub-register numbers for *n0.0* and *n0.2* are swapped on a write, i.e., a destination of *n0.0* is required to update *n0.2* and *n0.2* is required to update *n0.0*.

It should be noted that in the extreme case, it is possible to have more notifications to a thread than the maximum allowed number of concurrent threads in the system. Therefore, the range of the thread-to-thread notification count in *n0*, is larger than the maximum number of threads computed by $EUID * TID$.

There is only one bit for the host-to-thread notification count in *n1*.

Note: When thread context save/restore is enabled, the host to thread communication using *n1* is not supported.

When directly accessed, this register is read-only. If the value is non zero, the only way to alter the value is to use the *wait* instruction to decrement the value until zero is reached. A *wait* instruction on a zero notification sub-register causes the thread to stall, waiting for a notification signal from outside targeting the same sub-register. See the *wait* instruction for details.

Implementation Restriction: The notification registers are initialized to 0 after hardware/software reset. However, these registers are not reset at thread dispatch time.



Register and Subregister Numbers for Notification Registers

RegNum[3:0]	SubRegNum[4:0]
0000b = n0 All other encodings are reserved.	00000b = n0.0:ud 00100b = n0.1:ud 01000b = n0.2:ud All other encodings are reserved.

Notification Register 0 Fields

DWord	Bits	Description
0	31:16	Reserved. MBZ.
	15:0	Thread to Thread Notification Count. This register is used by the WAIT instruction for thread-to-thread synchronization. The value read from this register specifies the outstanding notifications received from other threads. It can be changed indirectly by using the WAIT instruction. See the WAIT instruction for details. Format: U16

Notification Register 1 Fields

DWord	Bits	Description
0	31:1	Reserved. MBZ.

Notification Register 2 Fields

DWord	Bits	Description
0	31:16	Reserved. MBZ.
	15:0	Thread to Thread Notification Count. This register is used by the WAIT instruction for thread-to-thread synchronization. The value read from this register specifies the outstanding notifications received from other threads. It can be changed indirectly by using the WAIT instruction. See the WAIT instruction for details. Format: U16

Format of the Notification Register

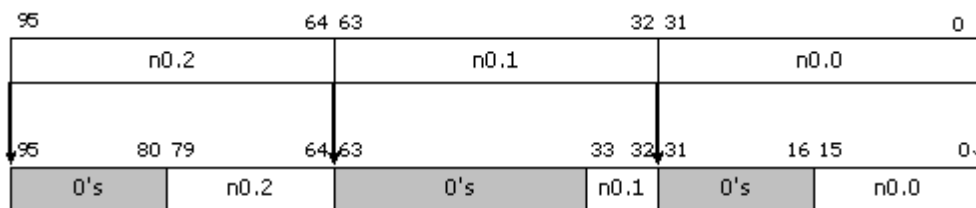

B6898-01



IP Register

IP Register Summary

Attribute	Value
ARF Register Type Encoding (RegNum[7:4]):	1010b
Number of Registers:	1
Default Value:	Provided by the Dispatcher
Normal Access:	RW
Elements:	1
Element Size:	32 bits
Element Type:	UD
Access Granularity:	DWord
Write Mask Granularity:	DWord
SecHalf Control?	No
Indexable?	No

The ip register can be accessed as a 32-bit quantity. It is a read-write register, containing the current instruction pointer, which is relative to the **Generate State Base Address**. Reading this register returns the instruction pointer of the current instruction. The 3 LSBs are always read as zero. Writing this register causes program flow to jump to the new address. When it is written, the 3 LSBs are dropped by hardware.

Register and Subregister Numbers for IP Register

RegNum[3:0]	SubRegNum[4:0]
0000b = ip	00000b = ip:ud
All other encodings are reserved.	All other encodings are reserved.

IP Register Fields

DWord	Bits	Subfield Description
0	31:3	Ip . Specifies the current instruction pointer. This pointer is relative to the General State Base Address .
	2:0	Reserved . MBZ.

TDR Registers

TDR Registers Summary

Attribute	Value
ARF Register Type Encoding (RegNum[7:4]):	1011b



Attribute	Value
Number of Registers:	8
Default Value:	No
Normal Access:	RO/CW
Elements:	8
Element Size:	16 bits
Element Type:	UW
Access Granularity:	Word
Write Mask Granularity:	Word
SecHalf Control?	No
Indexable?	No

There are 8 thread dependency registers (tdr0.0:uw to tdr0.7:uw) used by HW for the *sendc* instruction. These registers are read-only and can be accessed in 16-bit granularity.

When accessed explicitly, each thread dependency register has FFTID in the lower 8 bits, bits 8 to 14 are forced to zero by HW. Bit 15 is the valid bit, which indicate whether the current thread has a dependency on the dependency thread stored in this thread dependency register.

The thread dependency registers are read only, the valids can only be set with a thread dispatch, and are reset by broadcasting end of thread messages after a thread retired. The FFTID's can only be changed with a therad dispatch. Any write into any of the TDR registers will clear the valid bit for the particular TDR if the write enable is true, the FFTID portion is strictly read only.

Register and Subregister Numbers for TDR Registers

RegNum[3:0]	SubRegNum[4:0]
1011b = tdr0	00000b = tdr0.0:uw
All other encodings are reserved.	00010b = tdr0.1:uw
	00100b = tdr0.2:uw
	00110b = tdr0.3:uw
	01000b = tdr0.4:uw
	01010b = tdr0.5:uw
	01100b = tdr0.6:uw
	01110b = tdr0.7:uw
	All other encodings are reserved.

TDR Registers Fields

DWord	Bits	Description
-------	------	-------------



DWord	Bits	Description
3	31	Valid7. This field indicates whether the thread specified by FFTID7 is still in-flight.
	30:25	Reserved. MBZ
	24:16	FFTID7. This field is the FFTID of the third thread that the current thread depends on. It can be changed by the end of thread broadcasting messages. Format: U9
	15	Valid6. This field indicates whether the thread specified by FFTID6 is still in-flight.
	14:9	Reserved. MBZ
	8:0	FFTID6. This field is the FFTID of the third thread that the current thread depends on. It can be changed by the end of thread broadcasting messages. Format: U9
	2	31
30:25		Reserved. MBZ
24:16		FFTID5. This field is the FFTID of the third thread that the current thread depends on. It can be changed by the end of thread broadcasting messages. Format: U9
15		Valid4. This field indicates whether the thread specified by FFTID4 is still in-flight.
14:9		Reserved. MBZ
8:0		FFTID4. This field is the FFTID of the third thread that the current thread depends on. It can be changed by the end of thread broadcasting messages. Format: U9
1		31
	30:25	Reserved. MBZ
	24:16	FFTID3. This field is the FFTID of the third thread that the current thread depends on. It can be changed by the end of thread broadcasting messages. Format: U9
	15	Valid2. This field indicates whether the thread specified by FFTID2 is still in-flight.
	14:9	Reserved. MBZ
	8:0	FFTID2. This field is the FFTID of the third thread that the current thread depends on. It can be changed by the end of thread broadcasting messages. Format: U9
	0	31
30:25		Reserved. MBZ



DWord	Bits	Description
	24:16	FFTID1. This field is the FFTID of the third thread that the current thread depends on. It can be changed by the end of thread broadcasting messages. Format: U9
	15	Valid0. This field indicates whether the thread specified by FFTID0 is still in-flight.
	14:9	Reserved. MBZ
	8:0	FFTID0. This field is the FFTID of the third thread that the current thread depends on. It can be changed by the end of thread broadcasting messages. Format: U9

Performance Registers

Performance Registers Summary

Attribute	Value
ARF Register Type Encoding (RegNum[7:4]):	1100b
Number of Registers:	1
Default Value:	0h
Normal Access:	RO/RW
Elements:	3
Element Size:	32 bits
Element Type:	UD

Timestamp Register

This register is a low latency timestamp source, *TM*, available as part of a thread's Architectural Register File (ARF). This is a free running counter, 64b in size, and exposed to the ISA as individual 32b high *TmHigh* and low *TmLow* unsigned integer source operands. As part of the EU's register space, access to the timestamp has a low and deterministic latency and therefore can be used for intra-kernel high resolution performance profiling.

The TM features provides a 1-bit indicator *TmEvent* which identifies the occurrence of a time-impacting event such as context switch or frequency change since the last time any portion of the Timestamp register value was read by that thread. Software that uses the Timestamp capability should check this bit to identify when a relative time calculation may be suspect. To properly use this additional information, the instrumentation code should operate on the Timestamp register value as a whole (i.e. as an 8 dword register) so that the 64b time and this 1b value are captured simultaneously, as opposed to 32b portions, to eliminate a the chance of missing a TmEvent that might occur between accesses to 32b portions of this register.



Note: The Timestamp register is saved as part of thread state on context-save, but only *TmEvent* is restored (and technically always restored to 1 as a context switch had occurred).

Register and Subregister Numbers for Performance Register

RegNum[3:0]	SubRegNum[4:0]
0000b = <i>tm0</i> All other encodings are reserved.	00000b = tm0.0:ud . 00100b = tm0.1:ud . 01000b = tm0.2:ud 01100b = tm0.3:ud 10000b = tm0.4:ud All other encodings are reserved

Performance Register Fields

DWord	Bits	Description
0 (tm0.0:ud)	31:0	TmLow. The lower 32b of the 64b timestamp value sourced from Cr clock. Read-only. Format: U32
1 tm0.1:ud	31:0	TmHigh. The upper 32b of the 64b timestamp value sourced from Cr clock. Read-only. Format: U32
2 tm0.2:ud	31:1	Reserved
	0	TmEvent. Indicates a discontinuous time-impacting event (e.g. context switch, frequency change) occurred since any portion of the Timestamp register was last read, thus making any relative duration calculation based on this counter suspect. This bit is reset at the time a new thread is loaded, and on each read of any portion of the <i>Timestamp</i> register..
3 tm0.3 (pm0)	31:0	Undefined Format: U32
4 tm0.4:ud (tp0)	31:16	Reserved
	15:0	Pause Counter. The pause duration. A non-zero value written to this register causes execution of the thread to halt for the corresponding number of clocks. Lower 5 bits are always zero and therefore, writing value less than 64 must not result in a pause [15:10] – Reserved, must be written as zero; when read, returns zero. [9:5] - Count value. [4:0] – Reserved, must be zero.



DWord	Bits	Description
		Format: U16

Flow Control Registers

Flow Control Registers Summary

Attribute	Value
ARF Register Type Encoding (RegNum[7:4]):	1101b
Number of Registers:	39
Default Value:	None
Normal Access:	RW*

Register and Subregister Numbers for Flow Control Registers

RegNum[3:0]	SubRegNum[4:0]
0000b = fc0	00000b-11111b = fc0.0–fc0.31 .
0001b = fc1	00000b = fc1.0 . All other encodings are reserved.
0010b = fc2	00000b = fc2.0 . All other encodings are reserved.
0011b = fc3	00000b = fc3.0 . 00001b = fc3.1 . 00010b = fc3.2 . 00011b = fc3.3 . All other encodings are reserved.
0100b = fc4	00000b = fc4.0 . All other encodings are reserved.

These are special hardware registers used in handling flow control operations. These registers may be accessed **ONLY** in context save/restore operation using the SIP. These registers are accessed with the 'MOV' opcode. Use of any other opcode or access of these registers in non-context save/restore modes may result in undeterministic behaviour of hardware.

These registers are accessed as 256b registers. Parts of the 256b register may be redundant, depending on the hardware implementation of each register. The fields "RegNum" and "SubRegNum" are used together to address these registers.



Immediate

Two forms of immediate are provided as a source operand: scalar and vector.

The immediate field in a GEN instruction has 32 bits. For a word or an unsigned word immediate data, software must replicate the same 16-bit immediate value to both the lower word and the high word of the 32-bit immediate field in a GEN instruction.

For a scalar immediate, it can be of any of the specified numeric data types from a word to a dword. Byte and unsigned byte are not supported as the smallest internal type of the execution pipeline is word. These two numeric types are reserved for future extensions.

The immediate form of vector allows a constant vector to be in-lined in the instruction stream. Both integer and float immediate vectors are supported.

An immediate integer vector is denoted by type **v** or **uv** as *imm32:v* or *imm32:uv*, where the 32-bit immediate field is partitioned into 8 4-bit subfields. *Refer to the Numeric DataType Section* for description of the packing of vector integers to a dword.

An immediate float vector is denoted by type **vf** as *imm32:vf*, where the 32-bit immediate field is partitioned into 4 8-bit subfields. *Refer to the Numeric DataType Section* for the description of the packing of vector floats to a dword.

Restriction: *When an immediate vector is used in an instruction, the destination must be 128-bit aligned with destination horizontal stride equivalent to a word for an immediate integer vector (v) and equivalent to a dword for an immediate float vector (vf).*



Region Parameters

Unlike conventional SIMD architectures where an N-bit wide SIMD instruction can only operate on N-bit aligned SIMD data registers, a region-based register addressing scheme is employed in GEN architecture. The region-based register addressing capability significantly improves the SIMD computation efficiency by providing per-instruction-based multiple data gathering from register file. This avoids instruction overhead to perform data pack, unpack, and shuffling, which has been observed on other SIMD architectures. One benefit of such capability is allowing various kinds of 3D Graphics API Shader compute models to run efficiently on GEN. Another benefit is allowing high throughput of media applications, which tend to operate on byte or word data elements.

This can be illustrated by the example shown in *Region Parameters* and *Region Parameters*. As shown in *Region Parameters*, a sequence of SIMD instruction is executed on a conventional load/store based superscalar machine with SIMD instruction extension. The data parallelism can be achieved by first level of loop unrolling. As shown, there is a second level of loop for the task. Before a given SIMD compute instruction, *Process (i)*, can proceed, there might be a load, a data rearrange and a data unpack (and conversion) instruction to load and prepare the input data. After the compute instruction is complete, it might also require pack, re-arrange and store instructions, to format and save the same to memory. At the loop, other scalar computations such as loop count and address generation may be needed. For the same program, when the data can fit in the large GEN GRF register file, the outer loop may be unrolled for GEN. Here one or a few block loads (using *send* instruction) may be sufficient to move the working set into GRF. Then the data shuffle can be combined with the processing operation with region-based addressing capability. Per operand float type and mixed data type operation may also allow GEN to combine data conditioning operations with computing operations. These techniques in GEN architecture help to achieve high compute efficiency and throughput for graphics and media applications.

Conventional SIMD Instruction Sequence

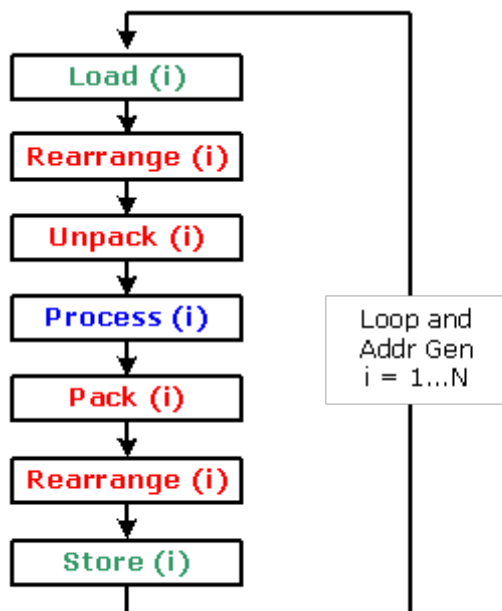

B6899-01



GEN SIMD Instruction Sequence for the Same Program

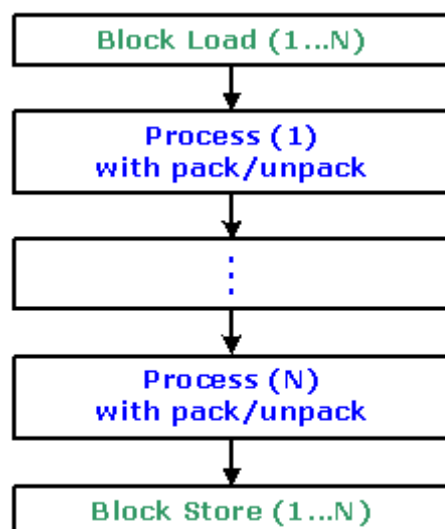

B6900-01

In a GEN instruction, each operand defines a region in the register file. A region may contain multiple data elements. Each data element is assigned to an execution channel in the EU. The total number of data elements of a region is called the **size** of the region, or the size of the operand. The number of execution channels is called the **execution size** (*ExecSize*), which is specified in the instruction word. ExecSize determines the size of region for source and destination operands in an instruction.

- For an instruction with two source operands, the sizes of the two source operands must be the same.
- The size of a destination operand generally matches the execution size, therefore equals to the number of source operand(s) in the same instruction.
 - Exception of this rule is present for the integer reduction instructions (such as sad2 and sada2) where the destination area is smaller than the source area.

Regions are **generalized 2-dimensional** (2D) arrays in row-major order. The first dimension is named the **horizontal** dimension (data elements within a row) and the second dimension is termed the **vertical** dimension (data elements in a column). Here, horizontal/vertical and row/column are just symbolic notations. When the GRF registers are viewed as a row-major 2D array of memory, such a notation normally matches well with the geometric locations of the data elements of an operand. However, as the register region is fully described by the parameters discussed below, the data elements of a register region may not form a regular rectangular shape. For example, Vertical Stride parameter is allowed to be smaller than Horizontal Stride, making the rows of a register region interleave with each other. It should also note that the meanings of horizontal/vertical here is different than that used for the flag control in Section *Flag Register*.

Specifically, a region-based description of a source operand can take the following format

RegFile RegNum.SubRegNum<VertStride;Width,HorzStride>.type



Parameters are as the follows.

- Register Region Origin (*RegFile*, *RegNum* and *SubRegNum*): This set of parameters, including the register file, *RegFile*, the register number, *RegNum*, and the sub-register number, *SubRegNum*, describes the register region origin, which is the location of the first data element of the operand. *RegNum* is in unit of 256-bit and *SubRegNum* is in unit of the data element size.
- Width (*Width*): *Width* specifies the number of data elements along the horizontal dimension, or the number of data elements of a row.
- Horizontal Stride (*HorzStride*): *HorzStride* specifies the step size between two adjacent data elements within a row. It is in unit of data element size, which is determined by the data element *Type*.
- Vertical Stride (*VertStride*): *VertStride* specifies the step size between two adjacent data elements along the vertical dimension (or the step size between two rows). It is again in unit of data element size, which is determined by the data element *Type*.
- Data Element Type (*Type*): *Type* specifies numeric data type (float, word, byte, etc.) of the data elements. All data elements within a region must have the same type.

In GEN, GRF and register files consist of a sequence of 256-bit registers. When viewing the register file (GRF for example) as a sequence of 256-bit aligned registers, *RegNum* field provides the register number, thus for the name. *SubRegNum* provides the sub-field addressing within a register. However, when viewing the register file as a byte addressable memory array, (*RegNum* and *SubRegNum*) is just a byte address within the register file with *SubRegNum* providing the lower 5 bits and *RegNum* providing the higher bits.

The execution size is specified for each instruction by the parameter *ExecSize*. The size of the vertical dimension is *ExecSize/Width*, based on the rule that the size of regions must equal to the execution size.

Region Parameters depicts the register region description. The example shows a register region of *r4.1<16;8,2>:w*, where the shaded fields denote the data elements in the region and the numbers in these fields are the execution channel assignments. The register region assumes that an *ExecSize* of 16 is set for the instruction. Each data element is a word (as noted by the type field *:w*). The origin of the region is at the second word of *r4*, denoted by *r4.1*. Each row of the region has 8 data elements (words) that are 2 data elements (words) apart. The distance between two rows is 16 words. Note that the region shown is for illustration purpose only. It does not represent a typical usage model nor a performance optimized mode.

An example of a register region (*r4.1<16;8,2>:w*) with 16 elements

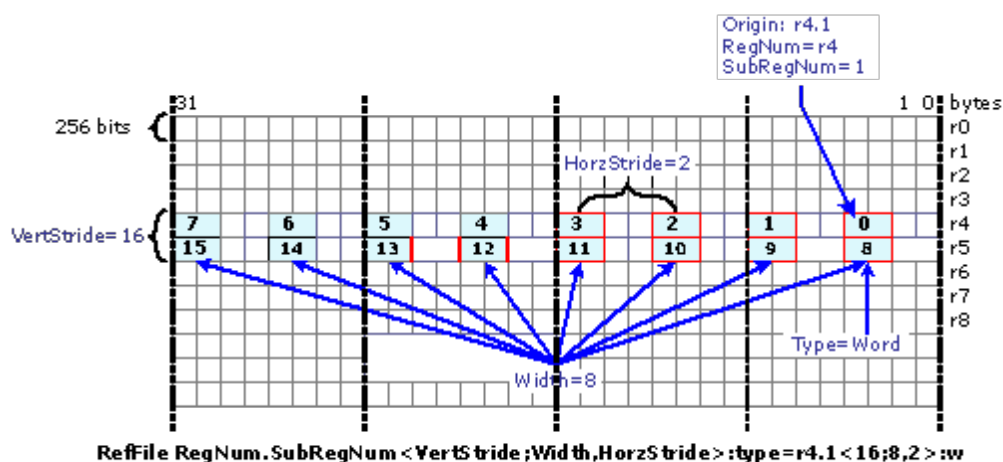

B6901-01

Region Parameters shows another example where the rows are interleaved. The region, having word data elements, starts at location r5.0:w. HorzStride, the distance within a row, is 2 words. So the second element (channel number 1) is at location 5.2:w. And there are 8 elements per row. VertStride, the distance between two rows, is only 1 word, which is less than HorzStride. Therefore, the first element of the second row (channel number 8) is at r5.1:w, just next to channel number 0. It is clear from the picture that the two rows are interleaved.

By varying the region parameters, reader may construct other configurations. The next section provides more details on the region-based register addressing. However, there are restrictions imposed by hardware implementation, which can be found in the later sections of this chapter.

A 16-element register region with interleaved rows (r5.0<1;8,2>:w)

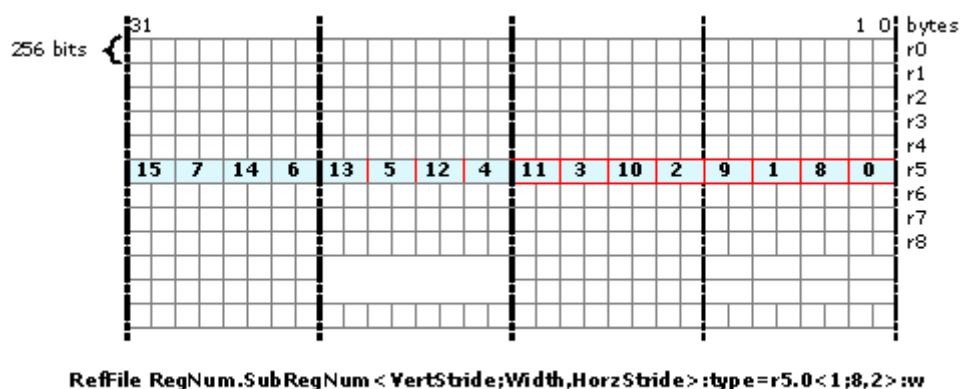

B6902-01

Without considering the source channel swizzle and destination register region description, the above row-major-order region description provides the data assignment to each execution channel. The following pseudo code computes the addresses of data elements assigned to execution channels for a special case when the destination register is aligned to 256-bit register boundary.

// Input: Type: ub | b | uw | w | ud | d | f | v

//RegNum: In unit of 256-bit register



```
//SubRegNum: In unit of data element size
//ExecSize, Width, VertStride, HorzStride: In unit of data elements
// Output: Address[0:ExecSize-1] for execution channels
int ElementSize = (Type==b||Type==ub) ? 1 : (Type==w|Type==uw) ? 2 : 4;
int Height = ExecSize / Width;
int Channel = 0;
int RowBase = RegNum<<5 + SubRegNum * ElementSize;
for (int y=0; y<Height; y++) {
    int Offset = RowBase;
    for (int x=0; x<Width; x++) {
Address [Channel++] = Offset;
Offset += HorzStride*ElementSize;
    }
    RowBase += VertStride * ElementSize;
}
```

As *HorzStride* and *VertStride* are specified independently (note that *VertStride* might be smaller than or equal to *HorzStride*), the region may take various shapes from a replicated scalar, a replicated vector, a vector of replicated scalars, a sliding window, to a non-overlapped 2D array.

A region-based description of a destination operand can take the following simplified format

RegFile RegNum.SubRegNum<HorzStride>.type

The destination operand is only allowed to have a 1 dimensional region. The Register Region Origin and Type are the same as for a source operand. The total number of elements is given by *ExecSize*. However, only *HorzStride* is required to describe the 1D region, not *VertStride* and *Width*.

As a source register region may cross multiple physical GRF registers, an instruction with such source operands may take more than two execution cycles to gather source data elements for execution. The destination register region is restricted to be within a physical GRF register. In other words, destination scatter writes over multiple registers are not supported.



Region Addressing Modes

There are two different register addressing modes: Direct register addressing and register-indirect register addressing. Depending on the register region description, the register-indirect register addressing mode can be further divided into three usages: 1x1 index region where only the origin of register region is provided by the address register, Vx1 index region where the offset of each row of the register region is provided by an address register, VxH index region where the offset of each data element is provided by an address register.

Direct Register Addressing

In this mode, all register region parameters are specified for an operand using fields in the instruction word.

Direct Register Addressing and *Direct Register Addressing* are two examples of direct register addressing.

For the example in *Direct Register Addressing*, all operands are 2D rectangular regions having the same size of 16 data elements. The two source operands, *Src0* and *Src1*, have 16 bytes. The destination operand, *Dst*, has 16 words. There are 8 elements in a row for *Src0* and *Src1*. The vertical stride of 16 bytes for *Src0* and *Src1* indicates that the first element and the 9th element are 16 bytes apart in the register file. Note that *Src0* falls into the 256-bit physical GRF register starting at r1.0, but *Src1* crosses the 256-bit physical GRF register boundary between r2 and r3. The numbers in the shaded regions are the values of the data elements. Observing the upper right corners of the source/destination regions (first data element), we have $C = 3+9$.

A region description example in direct register addressing

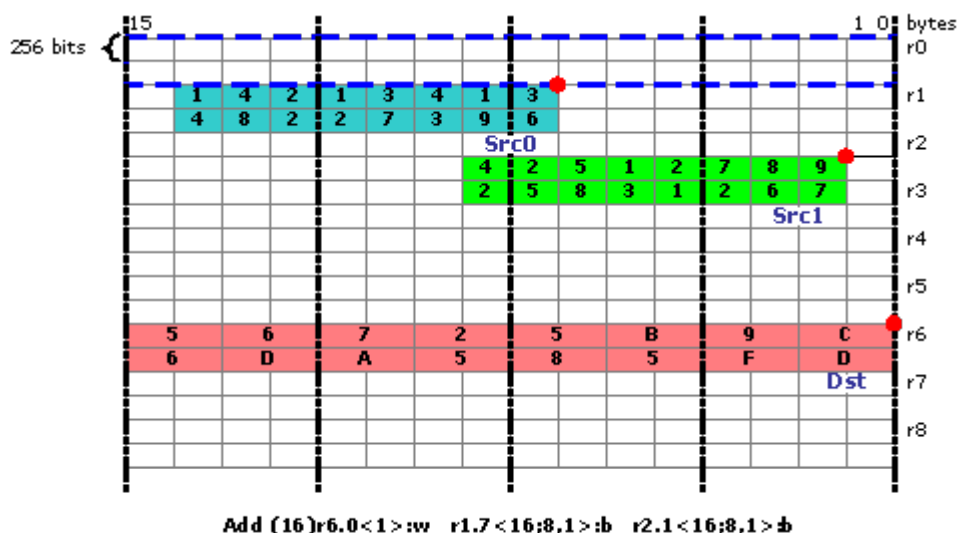

B6903-01

For the example in *Direct Register Addressing*, the sizes of areas of *Src0* and *Src1* are the same, but *Src0* contains a vector of replicated scalars. With $\text{HorzStride} = 0$ and $\text{Width} = 8$, the first row of 8 elements in *Src0* is a replication of the byte at r1.14. Comparing ExecSize of 16 to Width of 8 indicates that there is a



second row of 8 elements in *Src0*. With *VertStride* = 16, the second row in *Src0* is a replication of the byte at *r1.20* ($20 = 14 + 16$). Effectively, the 16 data elements of *Src0* are {1,1,1,1,1,1,1,1, 4,4,4,4,4,4,4,4}.

A region description example in direct register addressing with *src0* as a vector of replicated scalars

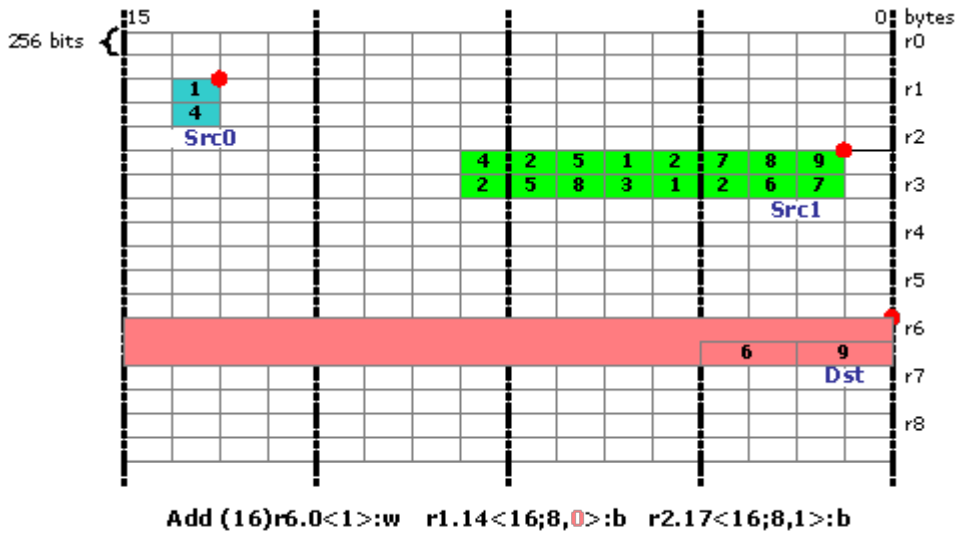

B6904-01

Register-Indirect Register Addressing with a 1x1 Index Region

In the register-indirect register addressing mode with 1x1 index region, the region origin is provided by the content of the address register, the rest of region parameters are provided by the fields in the instruction word.

Register-Indirect Register Addressing with a 1x1 Index Region depicts an example for this addressing mode. For example, the presence of a full region description $\langle 16;8,1 \rangle$ for *Src0* indicates that only the origin of the region is provided by the address register *a0.0*.

An example illustrating register-indirect register addressing mode with a 1x1 index region

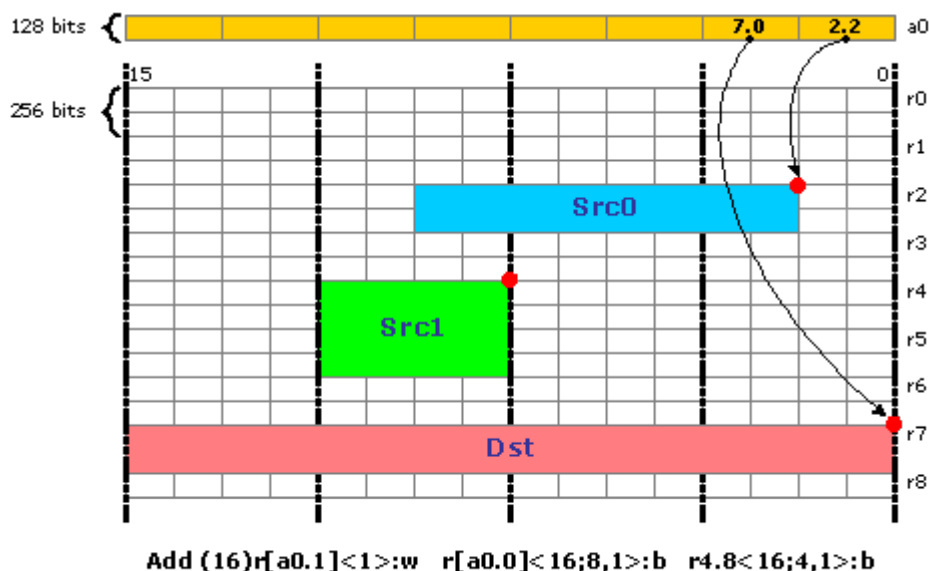

B 6905-01

Register-Indirect Register Addressing with a Vx1 Index Region

In the register-indirect register addressing mode with Vx1 index region, the horizontal dimension is described by the fields in the instruction word and the vertical dimension is described by an address register region. Specifically, the origin of each row of the data region is provided by the contents of an address register region. The rows are described by the width and the horizontal stride. The first address register is provided and the following contiguous address registers are for the following rows. The total number of address registers used is inferred from the parameters *ExecSize* and *Width*.

Within the 16-bit address register, bits 15:5 determine RegNum and bits 4:0 determine SubRegNum.

An example is provided in *Register-Indirect Register Addressing with a Vx1 Index Region*. The assembly syntax notion of a register region without vertical stride, <4,1>, corresponding to the special encoding of vertical stride of 0xF in the instruction word, indicates the VxH or Vx1 mode of indirect register addressing. In this case, the origin for each row of src0 is provided by the address register. As ExecSize/Width = 2, there are two address registers a0.0 and a0.1, each pointing to a row of 4 data elements.

An example illustrating register-indirect-register addressing mode with a Vx1 index region (src0)

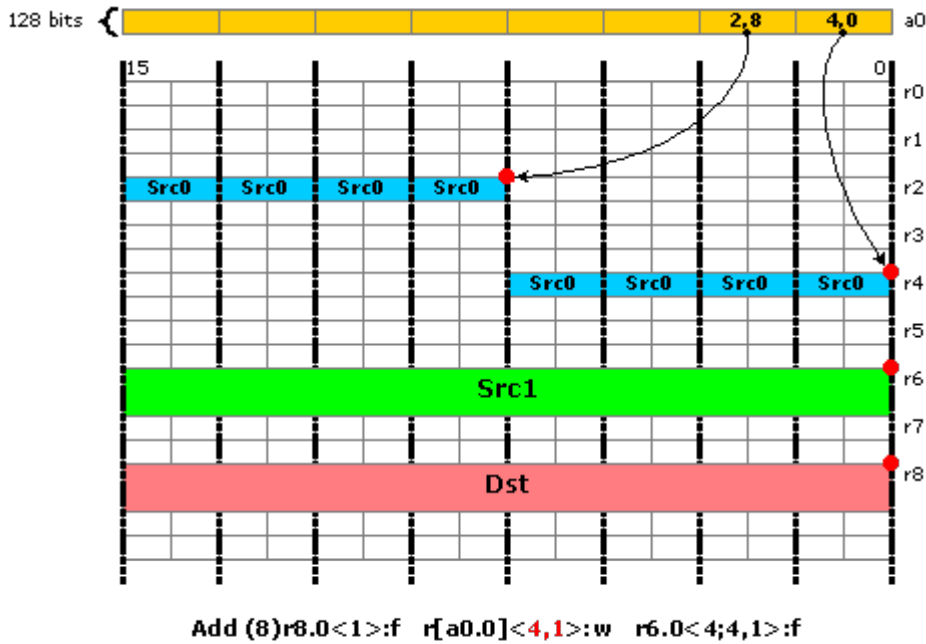

B6906-01

Register-Indirect Register Addressing with a VxH Index Region

In the register-indirect register addressing mode with VxH index region, the position of each data element is provided by the contexts in an address register region. This mode has the identical syntax as the Vx1 index region mode, and in fact, can be viewed as a special case of the Vx1 mode. When *Width* of the region is 1, the number of address registers used equals *ExecSize*.

An example is provided in *Register-Indirect Register Addressing with a VxH Index Region*. The absent of vertical stride in the region description <1,0> with width = 1 indicates that the origin for each row of 1 data element of Src0 is provided by the address register. As $ExecSize/Width = 8$, there are 8 address registers from a0.0 to a0.7, each pointing to a single data elements.

An example illustrating register-indirect register addressing mode with a VxH index region (Src0).

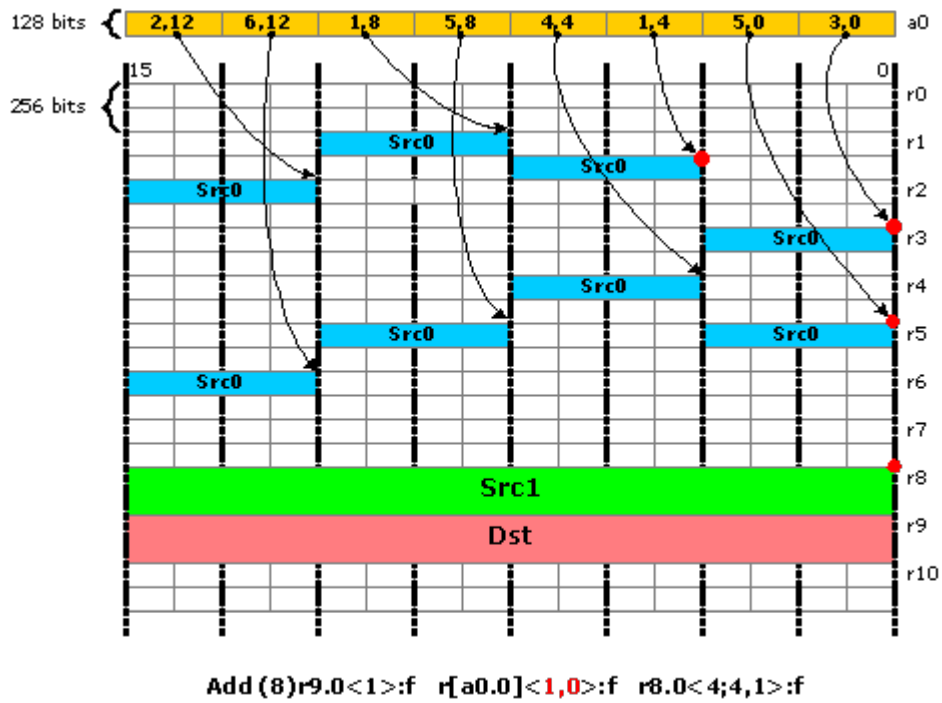

B6907-01



Access Modes

There are two basic GEN register access modes controlled by a single bit instruction subfield called Access Mode.

- 16-byte Aligned Access Mode (**align16**): In this mode, the origins of all operands (sources and destination), whether it is by direct addressing or register-indirect addressing, are 16-byte aligned. For example a row in the region description starts at 16-byte aligned and the width the row must be 4 and the 4 data elements within a row must span 16-bytes. In this access mode (and with other restrictions put forward later), full-channel swizzle for both source operands and per-channel mask for destination operand are supported on a 4-component basis. In other words, the control and setting of full source swizzle and destination mask are repeated for every 4 components up to total of *ExecSize* channels.
 - The **align16** access mode can be used for AOS operations. See examples provided in the Primary Usage Model section for SIMD4x2 and SIMD4x1 modes of operation to support 3D API Vertex Shader and Geometric Shader execution.
- 1-byte Aligned Access Mode (**align1**): In this mode, the origins of all operands may be aligned to their data type and could be 1-byte if the operand is of byte type. In this access mode, full region register descriptions are supported, however, source swizzle or destination mask are not supported.
 - The **align1** access mode can be used for SOA operations. See examples provided in the Primary Usage Model section for SIMD8 and SIMD16 modes of operation to support 3D API Pixel Shader. Many media applications also operate well in **align1** access mode.



Execution Data Type

The GEN architecture carries out arithmetic and logical operations using a smaller set of data types than the variety supported as source or destination operands. These are the *execution data types*. A particular arithmetic or logical instruction has one execution data type, from those listed in the table.

Table: Execution Data Types

Type	Description	Generation
W	Word. 16-bit signed integer.	
D	Doubleword. 32-bit signed integer.	
F	Float. 32-bit single precision floating-point number.	
DF	Double Float. 64-bit double precision floating-point number.	

The following rules explain the conversion of multiple source operand types, possibly a mix of different types, to one common execution type:

- For floating-point sources, all source operands must have the same floating-point type, with the exceptions below
 - A two-source floating-point instruction can have Float as the src0 type and VF (Packed Restricted Float Vector) as the immediate src1 type.
- Mixing floating-point and integer source types is not allowed. Either all source types must be one floating-point type or all source types must be integer types.
- Unsigned integers are converted to signed integers.
- Byte (B) or Unsigned Byte (UB) values are converted to a Word or wider integer execution type.
- If source operands have different integer widths, use the widest width specified to choose the signed integer execution type.

Note that when the execution data type is an integer type, it is always a signed integer type. For integer execution types, extra precision is provided within the hardware, including the accumulators, so that conversions from unsigned to signed do not affect instruction correctness.



Register Region Restrictions

A register region is described as *packed* if its elements are adjacent in memory, with no intervening space, no overlap, and no replicated values. If there is more than one element in a row, elements must be adjacent. If there is more than one row, rows must be adjacent. When two registers are used, the registers must be adjacent and both must exist.

The following register region rules apply to the GEN implementation.

1. General Restrictions Based on Operand Types

There are these general restrictions based on operand types:

1. Where n is the largest element size in bytes for any source or destination operand type, $ExecSize * n$ must be ≤ 64 .
2. When the **Execution Data Type** is wider than the destination data type, the destination must be aligned as required by the wider execution data type and specify a *HorzStride* equal to the ratio in sizes of the two data types. For example, a *mov* with a D source and B destination must use a 4-byte aligned destination and a *Dst.HorzStride* of 4.

2. General Restrictions on Regioning Parameters

The mapping of data elements within the region of a source operand is in row-major order and is determined by the region description of the source operand, the destination operand, and the *ExecSize*, with these restrictions:

1. *ExecSize* must be greater than or equal to *Width*.
2. If $ExecSize = Width$ and $HorzStride \neq 0$, *VertStride* must be set to $Width * HorzStride$.
3. If $ExecSize = Width$ and $HorzStride = 0$, there is no restriction on *VertStride*.
4. If $Width = 1$, *HorzStride* must be 0 regardless of the values of *ExecSize* and *VertStride*.
5. If $ExecSize = Width = 1$, both *VertStride* and *HorzStride* must be 0.
6. If $VertStride = HorzStride = 0$, *Width* must be 1 regardless of the value of *ExecSize*.
7. *Dst.HorzStride* must not be 0.
8. *VertStride* must be used to cross GRF register boundaries. This rule implies that elements within a '*Width*' cannot cross GRF boundaries.

A. Region Alignment Rules for Direct Register Addressing

1. In Direct Addressing mode, a source cannot span more than 2 adjacent GRF registers.
2. A destination cannot span more than 2 adjacent GRF registers.
3. When an instruction has a source region spanning two registers and a destination region contained in one register the number of elements must be the same between two sources and one of the following must be true:
 - a. The destination region is entirely contained in the lower OWord of a register.
 - b. The destination region is entirely contained in the upper OWord of a register.
 - c. The destination elements are evenly split between the two OWords of a register.



- When an instruction has a source region that spans two registers and the destination spans two registers, the destination elements must be evenly split between the two registers and each destination register must be entirely derived from one source register. **Note:** *In such cases, the regioning parameters must ensure that the offset from the two source registers is the same.*

The examples below illustrate the behavior of the cases permitted:

```
// Case (a) First 8 elements are from r12 to r10 and second from r13 to r11:
mov (16) r10.0<2>:w r12<16;8,1>:w
// The above instruction behaves the same as the following two instructions:
mov (8) r10.0<2>:w r12<8;8,1>:w
mov (8) r11.0<2>:w r13<8;8,1>:w

// Case (b) First 8 elements from r12.8 to r10 and second from r13 to r11:
mov (16) r10.0<2>:w r12.8<16;8,1>:w
// The above instruction behaves the same as the following two instructions:
mov (8) r10.0<2>:w r12.8<8;8,1>:w
mov (8) r11.0<2>:w r13.8<8;8,1>:w
```

The following examples indicate cases that are not allowed:

```
// Not allowed, because the source has 12 elements from r12 and 4 from r13:
mov (16) r10.0<2>:w r12.4<4;4,1>:w

// Not allowed, because the destination has 14 elements in r10 and 2 in r11:
mov (16) r10.2<1>:w r12<16;8,1>:w
```

- When destination spans two registers, the source **MUST** span two registers. The exception to the above rule:
 1. When source is scalar, the source registers are not incremented.
 2. When source is packed integer Word and destination is packed integer DWord, the source register is not incremented but the source sub register is incremented. Note: When lower 8 channels are disabled, the sub register of source1 operand is not incremented. If the lower 8 channels are expected to be disabled, say by predication, the instruction must be split into pair of simd8 operations.

The examples below illustrate the behavior of the cases permitted:

```
// Case (a) Scalar source:
mov (16) r10.0<2>:w r12.0<0;1,0>:w
// The above instruction behaves the same as the following two instructions:
mov (8) r10.0<2>:w r12.0<0;1,0>:w
mov (8) r11.0<2>:w r12.0<0;1,0>:w

// Case (b) First 8 elements from r12 to r10 and second from r12.8 to r11:
mov (16) r10.0<1>:d r12<8;8,1>:w
// The above instruction behaves the same as the following two instructions:
mov (8) r10.0<1>:d r12<8;8,1>:w
mov (8) r11.0<1>:d r12.8<8;8,1>:w

// Case (c) Example for Notes
add (16) r10.0<1>:d r12<8;8,1>:w r13<8;8,1>:w
// The above instruction must be split into
```



```
add (8) r10.0<1>:d r12.0<8;8,1>:w r13.0<8;8,1>:w {Q1}
add (8) r11.0<1>:d r12.8<8;8,1>:w r13.8<8;8,1>:w {Q2}
```

1. Special Cases for Byte Operations

1. When the destination type is byte (UB or B) only a 'raw move' using the *mov* instruction supports a packed byte destination register region: *Dst.HorzStride* = 1 and *Dst.DstType* = (UB or B). This packed byte destination register region is not allowed for any other instructions, including a 'raw move' using the *sel* instruction, because the *sel* instruction is based on Word or DWord wide execution channels.
2. There is a relaxed alignment rule for byte destinations. When the destination type is byte (UB or B), destination data types can be aligned to either the lowest byte or the second lowest byte of the execution channel. For example, if one of the source operands is in word mode (a signed or unsigned word integer), the execution data type will be signed word integer. In this case the destination data bytes can be either all in the even byte locations or all in the odd byte locations. This rule has two implications illustrated by this example:

```
// Example:
mov (8) r10.0<2>:b r11.0<8;8,1>:w
mov (8) r10.1<2>:b r11.0<8;8,1>:w

// Dst.HorzStride must be 2 in the above example so that the destination
// sub-registers are aligned to the execution data type, which is :w.
// However, the offset may be .0 or .1.
// This special handling applies to byte destinations ONLY.
```

2. Special Requirements for Handling Double Precision Data Types

1. In Align1 mode, all regioning parameters must use the syntax of a pair of packed floats, including channel selects and channel enables.

```
// Example:
mov (8) r10.0.xyzw:df r11.0.xyzw:df
// The above instruction moves four double floats. The .x picks the
// low 32 bits and the .y picks the high 32 bits of the double float.
```

2. In Align1 mode, all regioning parameters like stride, execution size, and width are in units of element size. However in Align16 mode, the channel selects and channel enables must always be used in pairs of packed floats, because these parameters are defined for DWord elements ONLY.

```
// Example:
mov (4) r10.0<1>:df r11.0<4;4,1>:df
// The above instruction moves four double floats.
```

3. Regioning Rules for Register Indirect Addressing

1. When the execution size and destination regioning parameters require two registers, each register is pointed to by adjacent index registers.

```
// Example:
mov (16) r[a0.0]:f r10:f

// The above instruction behaves the same as the following two instructions:
mov (8) r[a0.0]:f r10:f
```



```
mov (8) r[a0.1]:f r11:f
```

2. When the destination requires two registers and the sources are indirect, the sources must use 1x1 regioning mode. In addition, the sources must be assembled from GRF registers each accessed by adjacent index registers in 1x1 regioning modes. The data for each destination GRF register is entirely derived from one source register.

```
// Example:  
// Case (a):  
add (16) r[a0.0]:f r[a0.2]:f r[a0.4]:f  
// The above instruction behaves the same as the following two instructions:  
add (8) r[a0.0]:f r[a0.2]:f r[a0.4]:f  
add (8) r[a0.1]:f r[a0.3]:f r[a0.5]:f  
// Each access, source and destination, is a 1x1 regioning access.  
  
// Case (b):  
add (16) r[a0.0]:f r[a0.2]:f r[a0.4]<0;1,0>:f  
// The above instruction behaves the same as the following two instructions:  
add (8) r[a0.0]:f r[a0.2]:f r[a0.4]<0;1,0>:f  
add (8) r[a0.1]:f r[a0.3]:f r[a0.5]<0;1,0>:f
```

3. Indirect addressing on src1 must be a 1x1 indexed region mode.
4. When a Vx1 or a VxH addressing mode is used on src0, the destination must use ONLY one register.
5. Indirect addressing on the destination must be a 1x1 indexed region mode.
6. Data elements referenced by a single index within a source region cannot cross a 256-bit register boundary.
7. The lower bits of the AddressImmediate must not overflow to change the register address. The lower 5 bits of Address Immediate when added to lower 5 bits of address register gives the sub-register offset. The upper bits of Address Immediate when added to upper bits of address register gives the register address. Any overflow from sub-register offset is dropped.

4. Special Restrictions

1. **Note:** [DevHSW:GT2:A]: SIMD16 is not allowed for three-source instructions.
2. When an instruction is SIMD32, the low 16 bits of the execution mask are applied for both halves of the SIMD32 instruction. If different execution mask channels are required, split the instruction into two SIMD16 instructions.
3. Instructions with condition modifiers must not use SIMD32.
4. All flow control (branching) instructions must use the Align1 access mode.
5. When using Align16 mode for conversion of data elements of different sizes, both source and destination must be one register each.



Destination Operand Description

Destination Region Parameters

Based on the above restrictions, a subset of register region parameters are sufficient to describe the destination operand:

- Destination Register Origin
 - Destination Register Number and Destination Subregister Number for direct register addressing mode
 - A Scalar Destination Register Index for register-indirect-register addressing mode
- Destination Register *Region* – Note that destination register region does not have full region description parameters
 - Destination Horizontal Stride



SIMD Execution Control

Predication

Predication is the conditional SIMD channel selection for execution on a per instruction basis. It is an efficient way of dynamic SIMD channel enabling without paying branch instruction overhead. When predication is enabled for an instruction, a Predicate Mask (PMask), which contains 16-bit channel enables, is generated internally in EU. Note that PMask is not a software visible register. It is provided here to explain how SIMD execution control works. PMask generation is based on the Predication Control (*PredCtrl*) field, Predication Inversion (*PredInv*) field and the flag source register in the instruction word. See Instruction Summary chapter for definition of these fields.

The image below shows the block diagram of the hardware logic to generate PMask. PMask is generated based on combinatory logic operation of the bits in the flag register. Instruction field *PredCtrl* controls the horizontal evaluation unit and vertical evaluation unit. MUX A in the figure selects whether horizontally-evaluated results or vertically-evaluated results are sent to the Predication Inversion unit. The *PredInv* field controls the Prediction Inversion unit. Either one 16-bit flag sub-register or the whole flag register may be selected to generate the PMask depending on the predication control modes. MUX B indicates that predication can be enabled and disabled. Predication can be grouped into the following three categories. Predication functionality also depends on the Access Mode of the instruction.

- No predication: Of course, predication can be disabled. This is the most commonly used case.
- Predication with horizontal combination: the predicate mask is generated based on combinatory logic operation of bits within a selected flag sub-register.
- Predication with vertical combination: the predicate mask is generated based on combinatory logic operation of bits across flag multiple sub-registers.



Generation of predication mask

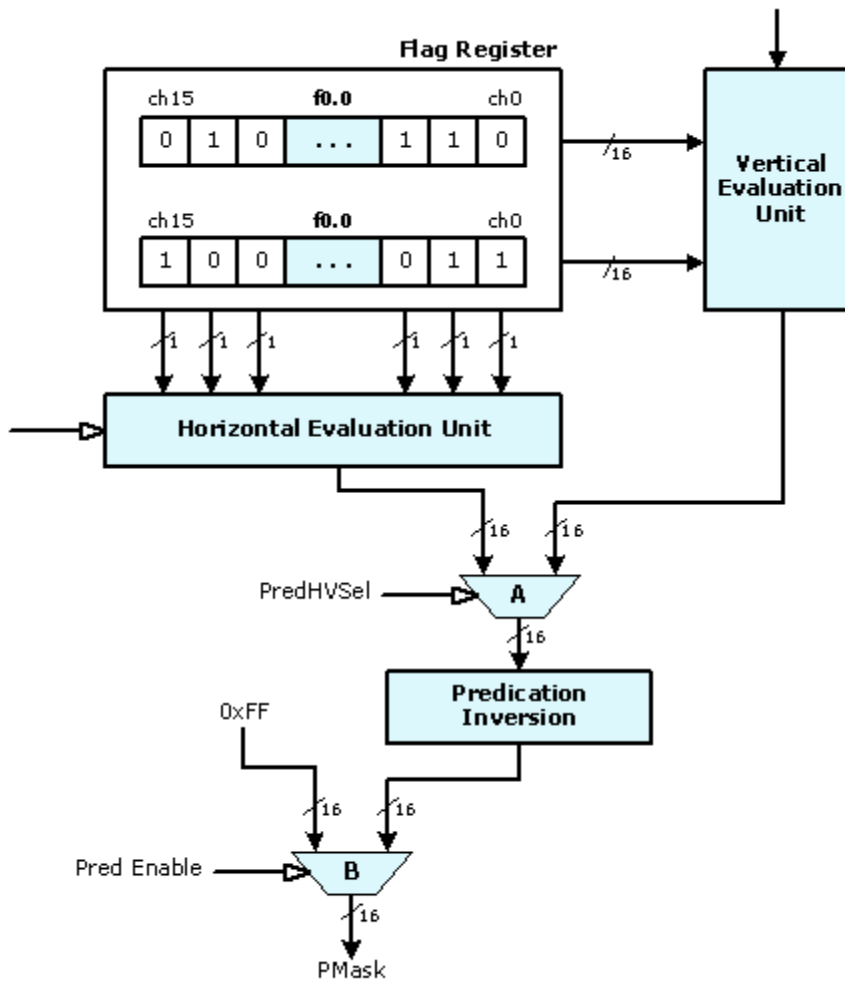

B.6908-01



No Predication

When PredCtrl field of a given instruction is set to 0 (*no predication*), it indicates that no predication is applied to this instruction. Effectively, the resulting PMask is all 1's. This is shown by the 2:1 multiplexer B controlled by the Pred Enable signal in *Predication*. Where predication is not enabled for an instruction, multiplex B is selected to output 0xFF to PMask.



Predication with Horizontal Combination

Predication with horizontal combination inputs the 16 bits of a single flag sub-register (f0.0:uw or f0.1:uw) and passes them through combinatory logic of the Horizontal Evaluation unit to create PMask.

The simplest combination is *no combination* – the same 16 bits from selected flag sub-register are output to MUX A. In this case, a bit in the selected flag sub-register controls the conditional execution of the corresponding execution channel. Let the selected flag sub-register be denoted as f0.#, the following pseudo code describes the predicate mask generation for predication with sequential flag channel mapping.

```
If (PredCtrl == Sequential flag channel mapping) {  
For (ch=0; ch<16; ch++)  
PMask[ch] = (PredInv == TRUE) ? ~f0.#[ch] : f0.#[ch];  
}
```

More complex horizontal evaluation is based on channel grouping. A group of adjacent channels (bits from flag sub-register) are evaluated together and a single bit is replicated to the group. The size of groups is in power of 2. The supported combination depends on the Access Mode of an instruction.

In **Align16** access mode, horizontal combination is based on 4-channel groups.

- Channel replication: PredCtrl of .x, .y, .z and .w select a single channel from each 4-channel group and replicate it as the output for the group. For example, PredCtrl = .x means that channel 0 in each group is replicated.
- OR combination: PredCtrl of .any4h means that if **any** of the channel in a group is enabled, outputs for the 4 channels in the group are all enabled.
- AND combination: PredCtrl of .all4h means that only when **all** of the channels in a group are enabled, the output for the group is enabled.

These combinations in **Align16** mode can be described by the following pseudo-code.

```
If (Access Mode == Align16) {  
For (ch = 0; ch < 16; ch += 4)  
Switch (PredCtrl) {  
Case .x: bTmp = f0.#[ch]; break;  
Case .y: bTmp = f0.#[ch+1]; break;  
Case .z: bTmp = f0.#[ch+2]; break;  
Case .w: bTmp = f0.#[ch+3]; break;  
Case .any4h: bTmp = f0.#[ch] | f0.#[ch+1] | f0.#[ch+2] | f0.#[ch+3]; break;  
Case .all4h: bTmp = f0.#[ch] & f0.#[ch+1] & f0.#[ch+2] & f0.#[ch+3]; break;  
}
```



```
bTmp = (PredInv == TRUE) ? ~bTmp : bTmp;
PMask[ch] = PMask[ch+1] = PMask[ch+2] = PMask[ch+3] = bTmp;
}
}
```

In **Align1** access mode, horizontal combination is based on AND combination *.any#h* and OR combination *.all#h* on channel groups with various sizes, where # is the number of channels in a group ranging from 2 to 16. This is described by the following pseudo-code.

```
If (Access Mode == Align1) {
Switch (PredCtrl) {
Case .any2h: groupSize = 2; <op> = |; break;
Case .all2h: groupSize = 2; <op> = &; break;
Case .any4h: groupSize = 4; <op> = |; break;
Case .all4h: groupSize = 4; <op> = &; break;
Case .any8h: groupSize = 8; <op> = |; break;
Case .all8h: groupSize = 8; <op> = &; break;
Case .any16h: groupSize = 16; <op> = |; break;
Case .all16h: groupSize = 16; <op> = &; break;
}
For (ch = 0; ch < 16; ch += groupSize) {
For (inc = 0, bTmp = FALSE; inc < groupSize; inc ++)
    bTmp = bTmp <op> f0.#[ch+inc];
    For (inc = 0; inc < groupSize; inc ++)
        PMask[ch+inc] = bTmp;
}
}
```



Predication with Vertical Combination

Predication with vertical combination uses both flag sub-register as inputs. The AND or OR combination is across the sub-registers on a channel by channel basis. This is shown by the following pseudo-code.

```
If (Access Mode == Align1) {  
    For (ch = 0; ch < 16; ch ++) {  
        If (PredCtrl == any2v)  
            PMask[ch] = f0.0[ch] | f0.1[ch]  
        Else If (PredCtrl == any2h)  
            PMask[ch] = f0.0[ch] & f0.1[ch]  
    }  
}
```



End of Thread

There is no special instruction opcode (such as an END instruction) to cause the thread to terminate execution. Instead, the end of thread is signified by a *send* instruction with the end-of-thread (EOT) sideband bit set. Upon executing a *send* instruction with EOT set, the EU stops on the thread. Upon observing an EOT signal on the output message bus, the Thread Dispatcher makes the thread's resource available. If a thread uses pre-allocated resource managed by a fixed function, such as URB handles and scratch memory, some fixed function protocol also requires the thread to terminate with the message header phase to carry the information in order for the fixed function to release the pre-allocated resource.

EU hardware guarantees that if a terminated thread has in-flight read messages or loads at the time of *end* that their writebacks will not interfere with either other threads in the system or new threads loaded in the system in the future.

More details can be found in the *send* instruction description in Instruction Reference chapter.



Assigning Conditional Flags

Instructions can output two sets of conditional signals, one set from before the outputs clamping/re-normalizing/format conversion logic, we call this the pre conditional signals. The second set is generated from the final results after clamping and re-normalizing/format conversion logic, and we call this the post conditional signals. The post conditional signals are used for fusing the DirectX compare instruction.

Note: The flags generated from the post conditional signals should be equivalent to the flags generated by a separate *cmp* instruction after the current arithmetic instruction.

The pre conditional signals are used to generated flags for *cmp/cmpn* instructions only, this logically does the compare of the two input sources. The post conditional signals are used to generated flags for all the other arithmetic instructions, this logically does the compare of the result with zero.

cmpn with both sources as NaNs is a don't care case as this doesn't impact the MIN/MAX operations.

The pre conditional signals include the following:

- **pre_sign** bit: This bit reflects the sign of the computed result before going through any kind of clamping, normalizing, or format conversion logic.
- **pre_zero** bit: This bit reflects whether the computed result is zero before any kind of clamping, normalizing, or format conversion logic.

The post conditional signals include the following:

- **post_sign** bit: This bit reflects the sign of the final result after all the clamping, normalizing, or format conversion logic.
- **post_zero** bit: This bit reflects whether the final result is zero after all the clamping, normalizing, or format conversion logic.
- **OF** bit: This bit reflects whether an overflow occurred in any of the computation of the current instruction, including clamping, re-normalizing, and format conversion.
- **NC** bit: The NaN computed bit indicates whether the computed result is not a number. It carries valid information for instructions operating on floating point values. For an operation on integer operands, this bit is always 0.
- **NS0** bit: The NaN Source 0 bit indicates whether src0 of an execution channel is not a number. It carries valid information for instructions operating on floating point values. For an operation on integer operands, this bit is always 0.
- **NS1** bit: The NaN Source 1 bit indicates whether src1 of an execution channel is not a number. It carries valid information for instructions operating on floating point values. For an operation on integer operands, this bit is always 0. For an operation with one source operand, this bit is also set to 0. This bit is only used for the comparison instruction *cmpn*, which is specifically provided to emulate MIN/MAX operations. For any other instructions, this bit is undefined.
- Note that the bits generated at the output of a compute are before the **.sat**.



Flag Generation for *cmp* Instructions (The Supported Conditional Modifiers are *.e*, *.ne*, *.g*, *.ge*, *.l*, and *.le*.)

Conditional Modifier	Meaning	Resulting Flag Value (for an execution channel)
.e	Equal-to	(pre_zero & ! (NS0 NS1)) . This conditional modifier tests whether the two sources are equal. If either source is NaN (i.e. NC is true), the flag is forced to false.
.ne	Not-Equal-to	! (pre_zero & ! (NS0 NS1)) . This conditional modifier test whether the two sources are equal. It takes exactly the reverse polarity as the modifier .e .
.g	Greater-than	(! pre_sign & ! pre_zero & ! (NS0 NS1)) . This conditional modifier tests whether src0 is greater than src1. If either source is a NaN (i.e. NC is true), the flag is forced to false.
.ge	Greater-than-or-equal-to	((! pre_sign pre_zero) & ! (NS0 NS1)) . This conditional modifier tests whether src0 is greater than or equal to src1. If either source is a NaN (i.e. NC is true), the flag is forced to false.
.l	Less-than	(pre_sign & !pre_zero & ! (NS0 NS1)) . This conditional modifier tests whether src0 is less than src1. If either source is a NaN (i.e. NC is true), the flag is forced to false.
.le	Less-than-or-equal-to	((pre_sign pre_zero) & ! (NS0 NS1)) . This conditional modifier tests whether src0 is less than or equal to src1. If either source is a NaN (i.e. NC is true), the flag is forced to false.

Flag Generation for *cmpn* Instructions (The Supported Conditional Modifiers are *.ge*, and *.l*)

Conditional Modifier	Meaning	Resulting Flag Value (for an execution channel)
.ge	Greater-than-or-equal-to	(! pre_sign (NS1 & (Opcode == <i>cmpn</i> Opcode == <i>sel with CMod</i>))) & ! (NS0 & (Opcode == <i>cmpn</i>)) . This conditional modifier tests whether src0 is greater than or equal to src1. If src1 is a NaN (i.e. NS is true), the flag is forced to true.
.l	Less-than	(pre_sign (NS1 & (Opcode == <i>cmpn</i> Opcode == <i>sel with CMod</i>))) & ! (NS0 & (Opcode == <i>cmpn</i>)) . This conditional modifier tests whether src0 is less than src1. If src1 is a NaN (i.e. NS is true), the flag is forced to true.



Flag Generation for All Instructions Other than *cmp/cmpn* Instructions (The Supported Conditional Modifiers are *.e*, *.ne*, *.g*, *.ge*, *.l*, *.le*, *.o*, and *.u*.)

Conditional Modifier	Meaning	Resulting Flag Value (for an execution channel)
.e	Equal-to	(post_zero & ! NC) . This conditional modifier tests whether the result is equal to zero. If either source is NaN (i.e. NC is true), the flag is forced to false.
.ne	Not-Equal-to	! (post_zero & ! NC) . This conditional modifier test whether the result is not equal to zero. It takes exactly the reverse polarity as modifier .e .
.g	Greater-than	(! post_sign & ! post_zero & ! NC) . This conditional modifier tests whether result is greater than zero. If either source is a NaN (i.e. NC is true), the flag is forced to false.
.ge	Greater-than-or-equal-to	((! post_sign post_zero) & ! NC) . This conditional modifier tests whether result is greater than or equal to zero. If either source is a NaN (i.e. NC is true), the flag is forced to false.
.l	Less-than	(post_sign & ! post_zero & ! NC) . This conditional modifier tests whether result is equal to zero. If either source is a NaN (i.e. NC is true), the flag is forced to false.
.le	Less-than-or-equal-to	((post_sign post_zero) & ! NC) . This conditional modifier tests whether result is equal to or less than zero. If either source is a NaN (i.e. NC is true), the flag is forced to false.
.o	Overflow	OF . This conditional modifier tests whether the computed result causes overflow – the computed result is outside the range of the destination data type. Note: The legacy condition modifier behavior is different from IEEE exception Overflow flag. For inf float to int conversion, .o will set the legacy Overflow flag, but IEEE exception Overflow flag won't be set. All other internal conditional signals are ignored.
.u	Unordered	NC . This conditional modifier tests whether the computed result is a NaN (unordered). All other internal conditional signals are ignored.



Destination Hazard

GEN architecture has built-in hardware to avoid destination hazard.

Destination Hazard stands for the risk condition when multiple operations are trying to write to the same destination and the result of the destination may be ambiguous. This may or may not happen on GEN for two instructions with the same destination, or with destinations that have overlapped register region, depending on the ordering of the arrival of destination results. Let's consider two instructions in a thread with potential destination hazard. There may be other instruction between them as long as there is no instruction sourcing the same destination. Using register scoreboards, GEN hardware automatically takes care of the destination hazard by not issuing the second instruction until the destination scoreboard is cleared. However, for certain cases, in fact for most cases, such destination hazard indicated by the register scoreboard is false, causing unnecessary delay of instruction issuing. This may result in lower performance. The destination dependency control field in the instruction word *{NoDDClr, NoDDhk}* allows software to selectively override such hardware destination dependency mechanism. Such performance optimization hooks must be used with extreme caution. When it is not certain that it is a false destination hazard, the programmer should rely on hardware to resolve the dependency.

As the destination dependency control field does not apply to *send* instruction, there is only one condition that a programmer may use the *{NoDDClr, NoDDChk}* capability.

- If none of the two instructions is *send*, there CANNOT be any destination hazard. This is because instructions within a thread are dispatched in order (single-issued) and the execution pipeline is in-order and has a fixed latency.

When a sequence of *NoDDChk* and *NoDDClr* are used, the last instruction that completes the scoreboard clear must have a non-zero execution mask. This means, if any kind of predication can change the execution mask or channel enable of the last instruction, the optimization must be avoided. This is to avoid instructions being shot down the pipeline when no writes are required.

Example:

```
(f0.0) mov r10.0 r11.0 {NoDDClr}
```

```
(-f0.0) mov r10.0 r11.0 {NoDDChk, NoDDClr}
```

In the above case, if predication can disable all writes to r10 for the second instructions, the instruction maybe shot down the pipeline resulting in un-deterministic behavior. Hence, this optimization must not be used in these cases.



Non-present Operands

Some instructions do not have two source operands and one destination operand. If an operand is not present for an instruction the operand field in the binary instruction must be filled with null. Otherwise, results are unpredictable.

Specifically, for instructions with a single source, it only uses the first source operand `src0`. In this case, the second source operand `src1` must be set to null and also with the same type as the first source operand `src0`. It is a special case when `src0` is an immediate, as an immediate `src0` uses DW3 of the instruction word, which is normally used by `src1`. In this case, `src1` must be programmed with register file ARF and the same data type as `src0`.



Instruction Prefetch

Due to prefetch of the instruction stream, the EUs may attempt to access up to 8 instructions (128 bytes) beyond the end of the kernel program – possibly into the next memory page. Although these instructions will not be executed, software must account for the prefetch in order to avoid invalid page access faults. One possible (though inefficient) solution would be to pad the end of all kernel programs with 8 NOOP instructions. A more efficient approach would be to ensure that the page after all kernel programs is at least valid (even if mapped to a dummy page). Note that the **General State Access Upper Bound** field of the STATE_BASE_ADDRESS command can be used to prevent memory accesses past the end of the General State heap (where kernel programs must reside).



ISA Introduction

This chapter contains these sections that introduce this volume.

- [Introducing the Execution Unit](#)
- [EU Terms and Acronyms](#)
- [EU Changes by Processor Generation](#)
- [EU Notation](#)

Subsequent chapters cover:

- [EU Data Types](#)
- [Execution Environment](#)
- [Exceptions](#)
- [Instruction Set Summary](#)
- [Instruction Set Reference](#)
- [EU Programming Guide](#)

The EU Programming Guide provides some useful examples and information but is not a complete or comprehensive programming guide.



Introducing the Execution Unit

This section introduces the Execution Unit (EU), a simple and capable processor within the GPU that supports graphics processing within the graphics pipelines, can do general purpose computing (GPGPU), and responds to exceptional conditions via the System Routine.

The EU provides parallelism at two levels: thread and data element. Multiple threads can execute on the EU; the number executing concurrently depends on the processor and is transparent to EU code. Each thread has its own registers (GRF and ARF, described below). Most EU instructions operate on arrays of data elements; the number of data elements is normally the *ExecSize* (*execution size*) or number of channels for the instruction. A *channel* is a logical unit of execution for data element access, masking, and flow control within instructions. The number of channels is independent of the number of physical ALUs or FPUs for a particular graphics processor.

EU native instructions are 128 bits (16 bytes) wide. Some combinations of instruction options can use compact instruction formats that are 64 bits (8 bytes) wide. Identifying instructions that can be compacted and creating the compact representations is done by software tools, including compilers and assemblers.

Data manipulation instructions have a destination operand (*dst*) and one, two, or three source operands (*src0*, *src1*, or *src2*). The instruction opcode determines the number of source operands. An instruction's last source operand can be an immediate value rather than a register.

Data read or written by a thread is generally in the thread's *GRF* (*General Register File*), 128 general registers, each 32 bytes. A data element address within the GRF is denoted by a register number (*r0* to *r127*) and a sub-register number. In the instruction syntax, sub-register numbers are in units of data element size. For example, a *:d* (Signed Doubleword Integer) element can be in sub-register 0 to 7, corresponding to byte numbers in the instruction encoding of 0, 4, ... 28.

Note: The EU cannot directly read or write data in system memory.

Specialized registers used to implement the ISA are in a distinct per thread *Architecture Register File* (*ARF*). Each such register or group of related registers has its own distinct name. For example, *ip* is the instruction pointer and *f0* is a flags register. An ARF register can be a *src0* or *dst* operand but not a *src1* or *src2* operand. There are restrictions on how particular ARF registers are accessed that should be understood before directly reading or writing those registers. See the [ARF Registers](#) section for more information.

The EU supports both integer and floating-point data types, as described in the [Numeric Data Types](#) section.

For EU flow control, each channel has its own per-channel instruction pointer (*PcIP[n]*) and only executes an instruction when $IP == PcIP[n]$ and any other masks enable the channel. Most flow control instructions use signed offsets from the current instruction address to reference their targets.

Unconditional branches are done using *mov* with *IP* as the destination. Flow control can also use SPF (Single Program Flow) mode to execute with a single instruction pointer (*IP*).



The EU ISA supports predication, masking, regioning, swizzling, some type conversions, source modification, saturation, accumulator updates, and flag updates as part of instruction execution:

- *Predication* creates a bit mask (*PMask*) to enable or disable channels for a particular instruction execution. Pmask is derived from flag register and sub-register values using boolean formulas determined by the PredCtrl (Predicate Control) and PredInv (Predicate Inversion) instruction fields. See the [Predication](#) section.
- *Masking* is the overall process of determining which channels execute for a given instruction based on five factors:
 - Number of channels (only channels in $[0, ExecSize - 1]$ can execute)
 - Execution mask (*EMask*)
 - Whether the channel is on the instruction (if not in Single Program Flow mode and MaskCtrl is not NoMask)
 - Predicate mask (*PMask*)
 - In Align16 mode, any enabling of channels using the Dst.ChanEn instruction field (if MaskCtrl is not NoMask).
- *Regioning* specifies an array of data elements contained in one or two registers, with options for scattering, interleaving, or repeating data elements in registers using width and stride values, subject to significant constraints. Regioning also includes access mode (Align1 or Align16) and addressing mode (Direct or Indirect). See the [Registers and Register Regions](#) section.
- *Swizzling* allows small scale reordering of data elements within groups of four at the input using the modulo 4 channel names x, y, z, and w. For example, a swizzle of .wzyx with an *ExecSize* of 8 reads execution channels 0 to 7 from these input channels: 3, 2, 1, 0, 7, 6, 5, and 4. Swizzling is only available in the Align16 access mode, described in the Execution Environment chapter.
- *Type Conversions* do any needed conversion from source data type to execution data type and from execution data type to destination data type. See [Execution Data Type](#) for more information. Each instruction description indicates what combinations of data types are supported.
- *Source Modification* modifies a source operand just before doing the requested operation. For a numeric operation, the choices are:
 - No modification (normal).
 - - indicating negation.
 - (abs) indicating absolute value.
 - -(abs) indicating a forced negative value.

Source modification logically occurs after any conversion from source data type to execution data type. Each instruction description indicates whether it supports source modification.

- *Saturation* clamps result values to the nearest value within a saturation range determined by the destination type. For a floating-point type, the saturation range is $[0.0, 1.0]$. For an integer type, the saturation range is the entire range for that type, for example $[0, 65535]$ for the UW (Unsigned Word) type. Each instruction description indicates whether it supports saturation.



- *Accumulator Updates* optionally update the accumulator register or registers in the ARF with destination values as a side effect of instruction execution. The AccWrCtrl instruction field enables accumulator updates. The Accumulator Disable flag in control register 0 (cr0) can be used to disable accumulator updates, regardless of AccWrCtrl values; for example, this flag may be used in the System Routine.
- *Flag Updates* optionally update a flags register and sub-register (f0.0, f0.1, f1.0, or f1.1) with conditional flags based on the CondModifier (Condition Modifier) instruction field. For example, a CondModifier of **.nz** (not zero) assigns flag bits based on whether result elements are not zero (1) or zero (0). Each instruction description indicates whether it supports the Condition Modifier and any restrictions on the values supported.

Note: The EU is not required to execute steps in its internal pipeline sequentially or in order, so long as it produces correct results.

The assembler syntax uses spaces between operands and encloses ExecSize and any predicate in parentheses. Instruction mnemonics, register names, conditional modifiers, predicate controls, and type designators use lowercase. Function names used with the math instruction are UPPERCASE.

```
( pred ) inst cmod sat ( exec_size ) dst src0 src1 { inst_opt, ... }
```

General register destination regions use the syntax *rm.n<HorzStride>:type*. General register directly addressed source regions use the syntax *rm.n<VertStride;Width,HorzStride>:type*. You need to understand more about register regioning to understand all of these terms.

The following example assembly language instruction adds two packed 16-element single-precision Float arrays in r4/r5 and r2/r3 writing results to r0/r1, only on those channels enabled by the predicate in f0.0 along with any other applicable masks.

```
(f0.0) add (16) r0.0<1>:f r2.0<8;8,1>:f r4.0<8;8,1>:f
```



EU Terms and Acronyms

This section provides three tables describing EU general terms and acronyms, EU data types, and EU selected ARF registers.

EU General Terms and Acronyms

Term	Description
ALT mode	A floating-point execution mode that maps +/- inf to +/- fmax, +/- denorm to +/-0, and NaN to +0 at the FPU inputs and never produces infinities, denormals, or NaN values as outputs. See IEEE mode.
ALU	Arithmetic Logic Unit. A functional block that performs integer arithmetic and logic operations, as distinct from instruction fetch and decode, floating-point operations (see FPU), or messaging.
AOS	Array Of Structures. Also see SOA .
ARF	Architecture Register File, a distinct register file containing registers used to implement specific ISA features. For example the Instruction Pointer and condition flags are in ARF registers. See GRF.
byte	An 8-bit value aligned on an 8-bit boundary and the basic unit of addressing. Bits within a byte are denoted 0 to 7 from LSB to MSB.
channel	A logical unit of SIMD data parallel execution within a thread and within the EU. The number of physical ALUs or FPUs is not directly related to the number of channels.
channel	Supports up to 32 channels.
compact instruction	A 64-bit instruction encoded as described in the EU Compact Instructions section. Only some combinations of instruction parameters can be encoded as compact instructions. See native instruction .
compressed instruction	An instruction that writes to two destination registers. For example a SIMD16 instruction with Float operands can write channels 0 to 7 to one 32-byte general register and channels 8 to 15 to a second, consecutive 32-byte general register.
denorm	A very small but nonzero number in IEEE mode, with a magnitude less than the smallest normalized floating-point number representable in a particular floating-point format. Denormals lose precision as their values approach zero, called <i>gradual underflow</i> .
DWord	Doubleword. A 32-bit (4-byte) value aligned on a 32-bit (4-byte) boundary. Bits within a DWord are denoted 0 to 31 from LSB to MSB.
EOT	End of Thread. A flag set on a <i>send</i> or <i>sendc</i> instruction to terminate a thread's execution on the EU.
EU	Execution Unit. The single GPU unit described in this volume. This volume describes individual data parallel execution paths within a thread in the EU as <i>channels</i> . A few fields, like EUID, use EU to refer to a particular hardware resource used to implement the overall EU.
exception	An error or interrupt condition that arises during execution that may transfer control to the System Routine. Some exceptions can be disabled, preventing such transfers. As defined in this volume, some errors do not produce exceptions.
ExecSize	The number of execution channels for a particular instruction. Channels within that number are enabled or disabled by various masks.
floating-point	Numeric types that allow fractional values and often a wider range than integer types. The EU



Term	Description
	supports binary floating-point types including the single precision type and the double precision typedefined by the IEEE 754 standard.
GEN	GEN is sometimes used to refer to Intel's mainstream GPU architecture integrated with recent CPU generations.
GRF	General Register File, a distinct register file containing 128 general registers, r0 to r127. Each general register is 256 bits (32 bytes), can contain any type of data, and can be accessed with any valid combination of addressing mode, access mode, and region parameters. A general register is directly addressed using a register number and sub-register number, or indirectly addressed using an address sub-register (index register) and an address immediate offset.
IEEE mode	A floating-point execution mode that supports all the kinds of floating-point values described by the IEEE 754 standard: normalized finite nonzero binary floating-point numbers, signed zeros, signed infinities, signed denormals that are closer to zero than any normalized value but still nonzero, and NaN (not a number) values. See ALT mode.
index register	An address sub-register when used for indirect addressing.
inf	Infinity, +inf or -inf, as a floating-point value in IEEE mode.
instruction	In this volume, <i>instruction</i> always refers to an EU instruction.
ISA	Instruction Set Architecture, processor aspects visible to programs and programmers and independent of a particular implementation, including data types, registers, memory access, addressing modes, exceptions, instruction encodings, and the instruction set itself. An ISA does not include instruction timing, hardware pipeline details, or the number of physical resources (ALUs, FPUs, instruction decoders) mapped to logical constructs (threads, channels). This volume also includes a recommended assembly language syntax, closely related to the ISA but logically distinct from it.
LSB	Least significant bit.
message	A data structure transmitted from a thread to another thread, to a shared function, or to a fixed function. Message passing is the primary communication mechanism of the GEN architecture.
MSB	Most significant bit.
NaN	Not a Number. A non-numeric value allowed in the standard single precision and double precision floating-point number formats. Quiet NaNs propagate through calculations and signaling NaNs cause exceptions. NaNs are not used in the ALT floating-point mode.
native instruction	A 128-bit instruction, the regular instruction format that allows all defined instruction parameters and options. Some instructions can also be encoded using a 64-bit compact instruction format.
OWord	Octword. A 128-bit (16-byte) value aligned on a 128-bit (16-byte) boundary. Bits within an OWord are denoted 0 to 127 from LSB to MSB. This term is used rarely and may be dropped from future versions of this volume.
packed	<p>A register region is described as <i>packed</i> if its elements are adjacent in memory, with no intervening space, no overlap, and no replicated values. If there is more than one element in a row, elements must be adjacent. If there is more than one row, rows must be adjacent. When two registers are used, the registers must be adjacent and both must exist.</p> <p>The immediate vector data types are all described as <i>Packed</i> because each such type packs several small data elements into a 32-bit immediate value.</p>



Term	Description
QWord	Quadword. A 64-bit (8-byte) value aligned on a 64-bit (8-byte) boundary. Bits within a QWord are denoted 0 to 63 from LSB to MSB.
region	A collection of data locations in registers and sub-registers for a source or destination operand. The associated regioning parameters allow regions to be arrays with various layouts.
register	Part of the directly accessible state of an EU program, such as a general register in the GRF or an architecture register in the ARF. Note that system memory is not directly accessible.
SIMD	Single Instruction Multiple Data. Each EU instruction can operate on multiple data elements in parallel, as specified by the instruction's ExecSize.
SIP	System Instruction Pointer, the starting IP value for the System Routine.
SOA	Structure of Arrays. Also see AOS .
SPF	Single Program Flow. A mode in which every execution channel uses the common instruction pointer, IP in the ip register. The SPF bit in the control register is 1 to enable SPF and 0 to disable it. If SPF is disabled, then each execution channel n has its own instruction pointer, PciP[n] and each channel n is only eligible to execute, subject to other masking, when PciP[n] == IP.
swizzle	Rearrange data elements within a vector. The EU supports modulo four swizzling of register source operands at the input in the Align16 access mode.
System Routine	A global EU exception handling routine. Any enabled exception from any EU thread transfers control to this routine.
thread	An instance of a program executing on the EU. The life cycle for a thread on the EU starts with the first instruction after being dispatched to the EU by the Thread Dispatcher and ends after executing a <i>send</i> or <i>sendc</i> instruction with EOT set, signaling thread termination. Threads can be independent or can communicate with each other via the Message Gateway shared function.
word	A 16-bit (2-byte) value aligned on a 16-bit (2-byte) boundary. Bits within a word are denoted 0 to 15 from LSB to MSB. <i>Word</i> has denoted a 16-bit unit for Intel processors since the 8086 and 8088 processors were introduced in 1978.

The next table lists all EU numeric data types. See the [Numeric Data Types](#) section for more information about each data type.

EU Numeric Data Types (Listed Alphabetically by Short Name)

Short Name	Assembler Syntax	Long Name	Size in Bytes	Size in Bits	Integral or Float	Description
B	:b	Signed Byte Integer	1	8	I	Signed integer in the range -128 to 127.
D	:d	Signed Doubleword Integer	4	32	I	Signed integer in the range -2^{31} to $2^{31} - 1$.
DF	:df	Double Float	8	64	F	Double precision floating-point number.
F	:f	Float	4	32	F	Single precision floating-point number.
UB	:ub	Unsigned Byte Integer	1	8	I	Unsigned integer in the range 0 to 255.
UD	:ud	Unsigned Doubleword Integer	4	32	I	Unsigned integer in the range 0 to $2^{32} - 1$.



Short Name	Assembler Syntax	Long Name	Size in Bytes	Size in Bits	Integral or Float	Description
UV	:uv	Packed Unsigned Half Byte Integer Vector	4	32	I	Eight 4-bit unsigned integer values each in the range 0 to 15. Only used as an immediate value.
UW	:uw	Unsigned Word Integer	2	16	I	Unsigned integer in the range 0 to 65,535.
V	:v	Packed Signed Half Byte Integer Vector	4	32	I	Eight 4-bit signed integer values each in the range -8 to 7. Only used as an immediate value.
VF	:vf	Packed Restricted Float Vector	4	32	F	Four 8-bit restricted float values. Only used as an immediate value.
W	:w	Signed Word Integer	2	16	I	Signed integer in the range -32,768 to 32,767.

The next table lists the seven ARF registers that you should understand first, omitting several others. See the [ARF Registers](#) section for more information, including descriptions of additional registers not listed below.

EU Selected ARF Registers (Listed Alphabetically by Name)

Name	Assembler Syntax	Description
Accumulators	acc0, acc1	Data registers that can hold integer or floating-point values of various sizes. Many instructions can implicitly update accumulators with a copy of destination values, done by setting the AccWrCtrl instruction option. A few instructions, like <i>mac</i> (Multiply Accumulate), use the accumulators as an implicit source operand, useful for some iterative calculations.
Address Register	a0.s	Holds sub-registers primarily used for indirect addressing. Each sub-register is a 16-bit UW (Unsigned Word) value. For an indirectly addressed operand or element, the sub-register value plus an AddrImm signed offset field determines the byte address (RegNum and SubRegNum) within the register file (GRF). There are 8 address sub-registers.
Control Register	cr0.s	Contains bit fields for floating-point modes, flow control modes, and exception enable/disable. Also contains exception indicator flags and saves the AIP (Application Instruction Pointer) on transferring control to the System Routine to handle an exception.
Flags	fr.s	Used as the outputs for various channel conditional signals, such as equality/zero or overflow. Used as the inputs for predication. There are two 32-bit flags registers each containing two 16-bit sub-registers.
Instruction Pointer (IP)	ip	References the current instruction in memory, as an unsigned offset from the General State Base Address. IP is the thread's overall instruction pointer. Each channel n can have its own instruction pointer (PcIP[n]). If not in Single Program Flow mode (SPF is



Name	Assembler Syntax	Description
		0) then only those channels where $PcIP[n] == IP$ are eligible to execute the instruction, if enabled by all other applicable masks.
Null Register	null	Indicates a non-existent operand. Unused operands in the instruction format, like the unused second source operand field in a <i>mov</i> instruction, are encoded as null. For present source operands, reading a null source operand returns undefined values. For null destination operands, results are discarded but any implicit updates to accumulators or flags still occur.
State Register	sr0.s	Contains thread identification and scheduling fields, and mask fields for enabling or disabling channels.

Execution Units (EUs)

Each EU is a vector machine capable of performing a given operation on as many as 16 pieces of data of the same type in parallel (though not necessarily on the same instant in time). In addition, each EU can support a number of execution contexts called *threads* that are used to avoid stalling the EU during a high-latency operation (external to the EU) by providing an opportunity for the EU to switch to a completely different workload with minimal latency while waiting for the high-latency operation to complete.

For example, if a program executing on an EU requires a texture read by the sampling engine, the EU may not necessarily idle while the data is fetched from memory, arranged, filtered and returned to the EU. Instead the EU will likely switch execution to another (unrelated) thread associated with that EU. If that thread encounters a stall, the EU may switch to yet another thread and so on. Once the Sampler result arrives back at the EU, the EU can switch back to the original thread and use the returned data as it continues execution of that thread.

The fact that there are multiple EU cores each with multiple threads can generally be ignored by software. There are some exceptions to this rule: e.g., for

- thread-to-thread communication (see *Message Gateway, Media*)
- synchronization of thread output to memory buffers (see *Geometry Shader*).

In contrast, the internal SIMD aspects of the EU are very much exposed to software.

This volume will not deal with the details of the EUs.



EU Changes by Processor Generation

This section describes how the EU changes for particular processor generations. Instruction compaction tables can differ for each generation, so that is not mentioned in these lists. Particular readers and audiences can see only certain content in this section. Notes and workarounds for particular generations, SKUs, or steppings are not included in these lists. Some small changes in instruction layouts are not included in these lists.

Pre-Haswell

These features or behaviors are added Pre-Haswell, continuing for Haswell:

- The maximum *ExecSize* increases to 32, for byte or word operands.
- Increase the number of flag registers from one to two.
- Add the *NibCtrl* field, used with *QtrCtrl* to select groups of channels or flags.
- Add the DF (Double Float) data type, the first time an 8-byte data type is supported. DF only supports the IEEE floating-point mode and not the ALT floating-point mode.
- Add a shared source data type field and a destination data type field for instructions with three source operands, allowing F (Float), DF (Double Float), D (Signed Doubleword Integer), or UD (Unsigned Doubleword Integer) types to be specified.
- Add bit manipulation instructions: *bfi1*, *bfi2*, *bfrev*, *cbit*, *fbh*, and *fbl*.
- Add the integer *addc* (Add with Carry) and *subb* (Subtract with Borrow) instructions.
- Add the *brc* (Branch Converging) and *brd* (Branch Diverging) instructions.
- For the *cmp* and *cmpn* instructions, relax the accumulator restrictions.
- For the *sel* instruction, remove the accumulator restriction.
- Add the Rounding Mode and Double Precision Denorm Mode fields in Control Register 0.

Haswell

- DF (Double Float) operands use an element size of 8. Regioning and channel parameters for the DF type are determined normally, in the same way as for other types.
- Add the channel enable register, flow control registers, and stack pointer register in the ARF.
- In the Control Register, add the Force Exception Status and Control, Context Save Status, and Context Restore Status bits.
- Relative instruction offsets (JIP, UIP) are now 32-bit values in units of bytes (rather than 16-bit values using 8-byte units) for some instructions: *brc*, *brd*, *call*, and *jmp*.
- A *call* instruction can get the relative instruction offset (JIP) from a register.
- Add the *calla* (Call Absolute) instruction.
- A *mov* instruction with different source and destination types can now use conditional modifiers.

These features or behaviors are specific to HSW and may not continue to later generations:

- Add the *dim* (Double Precision Floating Point Immediate Data Move) instruction.



- The *f16to32* and *f32to16* instructions are supported to convert between half-precision float and Float.
- The *mul* instruction limits integer multiplication involving DWords so that only the low 16 bits of *src1* are used even if *src1* is a DWord.
- The *sel* (Select) instruction does not support an *ExecSize* of 32.



EU Notation

The `Courier New` font is used for code examples and for the Syntax, Format, and Pseudocode sections in the instruction reference.

The *italic* font style is used for instruction mnemonics outside of code (e.g., the *send* instruction), for syntactic production names, for key values in algorithms (*ExecSize*), and to emphasize a word or phrase. For example: When bit 10 is set, the destination register scoreboard is *not* cleared.

The **bold** font weight is used for the short name and long name of a bit field being described, for value names being defined, for syntactic terminals, for unnumbered subheadings, and for the terms Note, Note/Notes, or Workaround used to introduce a paragraph.

Bit field names and value names used where not being defined and not as syntactic terminals are in plain text.

Bit field values in hex use the 0x prefix. The PRM currently uses the 0x prefix for hex in some parts and the h suffix for hex in other parts. For single bits, values appear as simply 0 or 1. For multi-bit binary values, the appropriate number of binary digits appears with a b suffix.

Instruction mnemonics are lowercase. Function names invoked using the *math* instruction are UPPERCASE. For example, SQRT.

Device names are in plain text in square brackets. For example, [HSW].

Tables describing bit field layouts or registers proceed from most significant to least significant bits. Figures showing bit fields or registers show most significant bits on the left and least significant bits on the right.

Any bit, field, or register described as Reserved should be regarded as undefined and unpredictable. Such bits should be treated as follows:

- When testing values, do not depend on the state of reserved bits. Mask out or otherwise ignore such bits.
- Sometimes software must initialize reserved bits. For example, a compiler must write complete instruction values when creating an instruction stream, including reserved bits. In such cases, write reserved bits as zeros unless otherwise indicated.
- Do not use reserved bits as extra storage for software-defined values; put nothing in such bits.
- When saving state and restoring state, save and restore any reserved bits as well.
- Do not assume that reserved bits are invariant between explicit writes. Software should function even if reserved bits change in undefined and unpredictable ways.

Any value, encoding, or combination of values or encodings described as Reserved must not be used. The EU's behavior is undefined in this case.

When a combination of instruction parameters or an EU state is described as producing undefined results or behavior, do not assume that undefined results or behavior are confined to specific instructions, operands, registers, or channels.



EU Data Types

[Fundamental Data Types](#)

[Numeric Data Types](#)

[Floating Point Modes](#)

- [IEEE Floating Point Mode](#)
 - [Partial Listing of Honored IEEE 754 Rules](#)
 - [Complete Listing of Deviations or Additional Requirements vs IEEE 754](#)
 - [Comparison of Floating Point Numbers](#)
 - [Min/Max of Floating Point Numbers](#)
- [Alternative Floating Point Mode](#)

[Type Conversion](#)

Fundamental Data Types

The fundamental data types in the GEN architecture are halfbyte, byte, word, doubleword (DW), quadword (QW), double quadword (DQ) and quad quadword (QQ). They are defined based on the number of bits of the data type, ranging from 4 bits to 256 bits. As shown in the figure below, a halfbyte contains 4 bits, a byte contains 8 bits, a word contains two bytes, a doubleword (DWord) contains two words, and so on. Halfbyte is a special data type that is not accessed directly as a standalone data element; it is only allowed as a subfield of the numeric data type of *packed signed halfbyte integer vector* described in the next section.

Fundamental Data Types

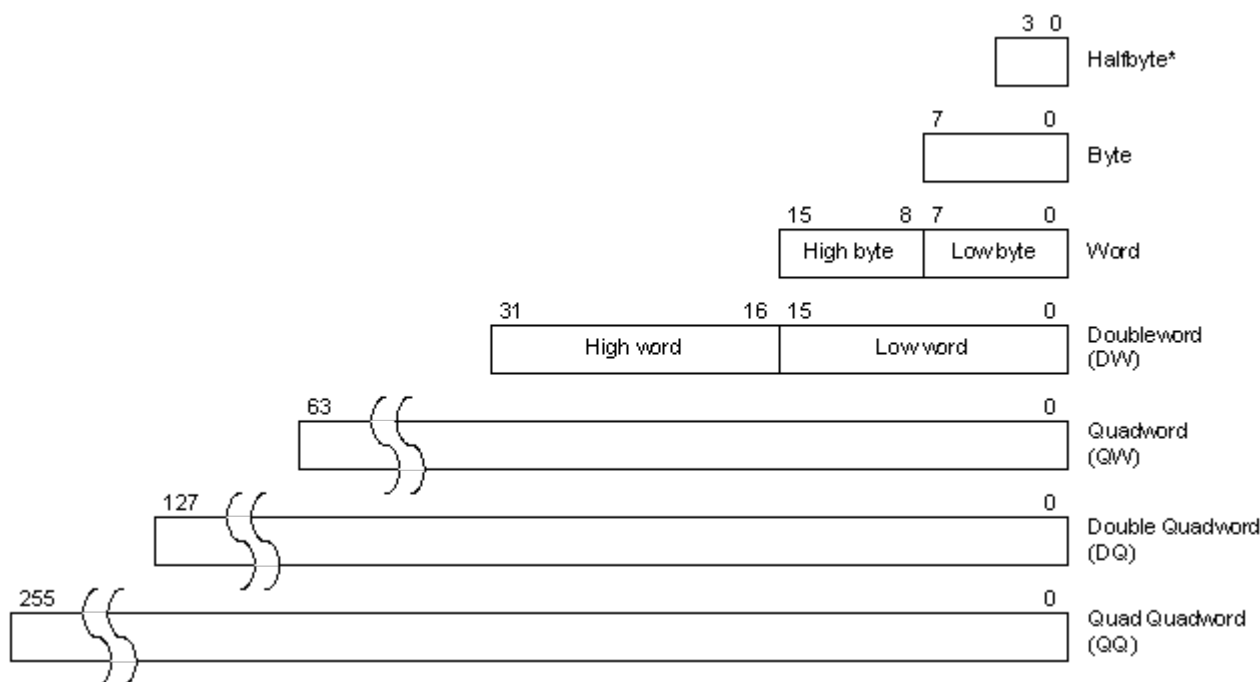

With the exception of halfbyte, the access of a data element to/from a GEN register or to/from memory must be aligned on the natural boundaries of the data type. The natural boundary for a word has an even-numbered address in units of bytes. The natural boundary for a doubleword has an address divisible by 4 bytes. Similarly, the natural boundary for a quadword, double quadword, and quad quadword has an address divisible by 8, 16, and 32 bytes, respectively. Double quadword, and quad quadword do not have corresponding numeric data types. Instead, they are used to describe a group (a vector) of numeric data elements of smaller size aligned to larger natural boundaries.

Numeric Data Types

The numeric data types defined in the GEN architecture include signed and unsigned integers and floating-point numbers (floats) of various sizes. These numeric data types are described below.

Integer Numeric Data Types

The Execution Unit supports the following integer data types. Signed integer types use two's complement representation for negative numbers.

UB: Unsigned Byte, 8-bit Unsigned Integer

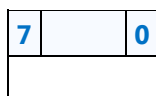

B: Byte, 8-bit Signed Integer

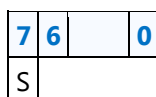



Notation	Size in Bits	Name	Range	Generation
		Integer		
D	32	Signed Doubleword Integer	$[-2^{31}, 2^{31} - 1]$	DevSNB+
UV	32	Packed Unsigned Half-Byte Integer Vector	[0, 15] in each of eight 4-bit immediate vector elements.	DevSNB+
V	32	Packed Signed Half-Byte Integer Vector	[-8, 7] in each of eight 4-bit immediate vector elements.	DevSNB+

Restriction: Only a raw move using the *mov* instruction supports a packed byte destination register region. For information about raw moves, refer to the **Description** in .

Floating-Point Numeric Data Types

The Execution Unit supports the following floating-point data types. The Float type uses the single precision format specified in IEEE Standard 754-1985 for Binary Floating-Point Arithmetic. The Double Float type uses the double precision format specified in IEEE Standard 754-1985 for Binary Floating-Point Arithmetic. In the ALT floating-point mode, representations for infinities, denorms, and NaNs within those formats are not used. The EU does not support the double extended precision (80-bit) floating-point format found in the x86/x87/Intel 64 floating-point registers. All floating-point formats are signed using signed magnitude representation (a distinct sign bit, separate from the magnitude information).

The F (Float) type supports both the ALT and IEEE floating-point modes, controlled by the Single Precision Floating-Point Mode bit in the Control Register.

In IEEE mode, F calculations flush denormalized values to zero and gradual underflow is not supported.

The DF (Double Float) type only supports the IEEE floating-point mode. Whether DF calculations support denorms or flush denormalized values to zero is controlled by the Double Precision Denorm Mode bit in the Control Register.

F: Float, 32-bit Single-Precision Floating-Point Number

3	3		2	2				
1	0		3	2				0
S	biased exponent			fraction				

DF: Double Float, 64-bit Double-Precision Floating-Point Number DevIVB+

6	6		5	5				
3	2		2	1				0
S	biased exponent			fraction				



VF: Packed Restricted Float Vector, 4 x 8-Bit Restricted Precision Floating-Point Number

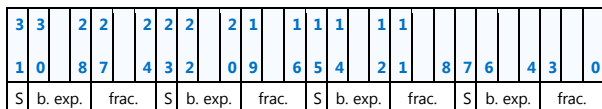

The following table summarizes the EU floating-point data types.

Execution Unit Floating-Point Data Types

Notation	Size in Bits	Name	Range	Generation
F	32	Float	Single precision, 1 sign bit, 8 bits for the biased exponent, and 23 bits for the significand: $[-(2-2^{-23})^{127} \dots -2^{-149}, 0.0, 2^{-149} \dots (2-2^{-23})^{127}]$	DevSNB+
DF	64	Double Float	Double precision, 1 sign bit, 11 bits for the biased exponent, and 52 bits for the significand: $[-(2-2^{-52})^{1023} \dots -2^{-1074}, 0.0, 2^{-1074} \dots (2-2^{-52})^{1023}]$	DevIVB+
VF	32	Packed Restricted Float Vector	Restricted precision. Each of four 8-bit immediate vector elements has 1 sign bit, 3 bits for the biased exponent (bias of 3), and 4 bits for the significand: $[-31 \dots -0.125, 0, 0.125 \dots 31]$	DevSNB+

Packed Signed Half-Byte Integer Vector

A packed signed halfbyte integer vector consists of 8 signed halfbyte integers contained in a doubleword. Each signed halfbyte integer element has a range from -8 to 7 with the sign on bit 3. This numeric data type is only used by an immediate source operand of doubleword in a GEN instruction. It cannot be used for the destination operand or a non-immediate source operand. GEN hardware converts the vector into an 8-element signed word vector by sign extension. This is illustrated in *Numeric Data Types*.

The short hand format notation for a packed signed half-byte vector is **V**.

Converting a Packed Half-Byte Vector to a 128-bit Signed Integer Vector

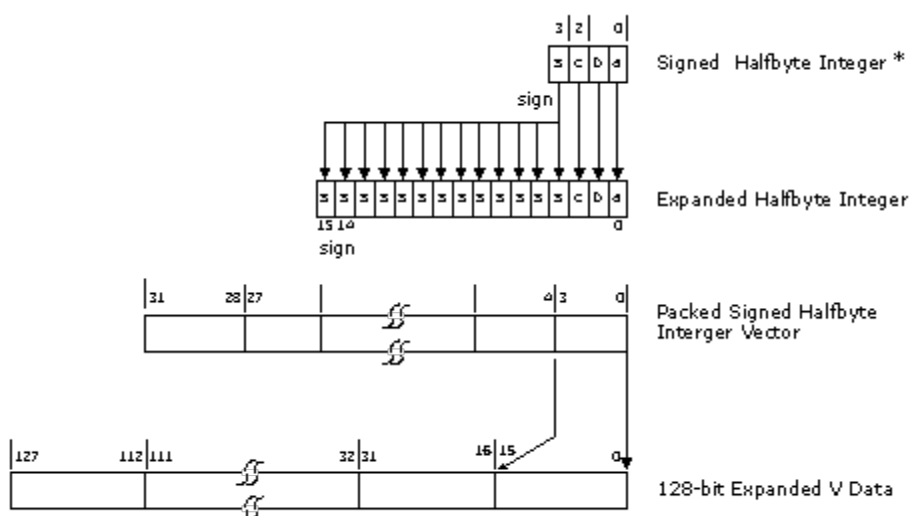

B6885-01

Packed UnSigned Half-Byte Integer Vector

A packed unsigned halfbyte integer vector consists of 8 unsigned halfbyte integers contained in a doubleword. Each unsigned halfbyte integer element has a range from 0 to 15. This numeric data type is only used by an immediate source operand of doubleword in a GEN instruction. It cannot be used for the destination operand or a non-immediate source operand. GEN hardware converts the vector into an 8-element signed word vector.

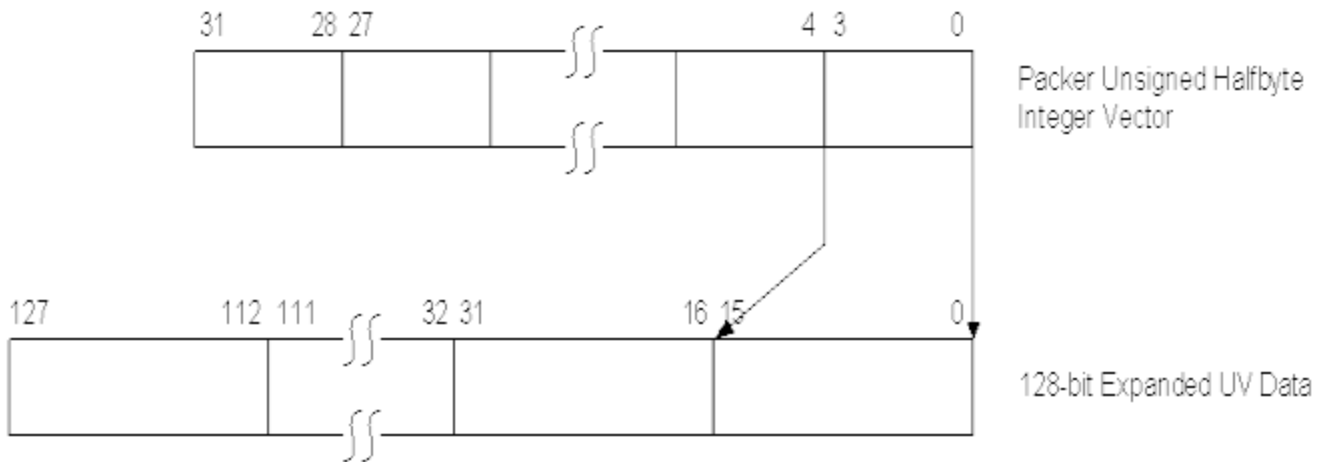
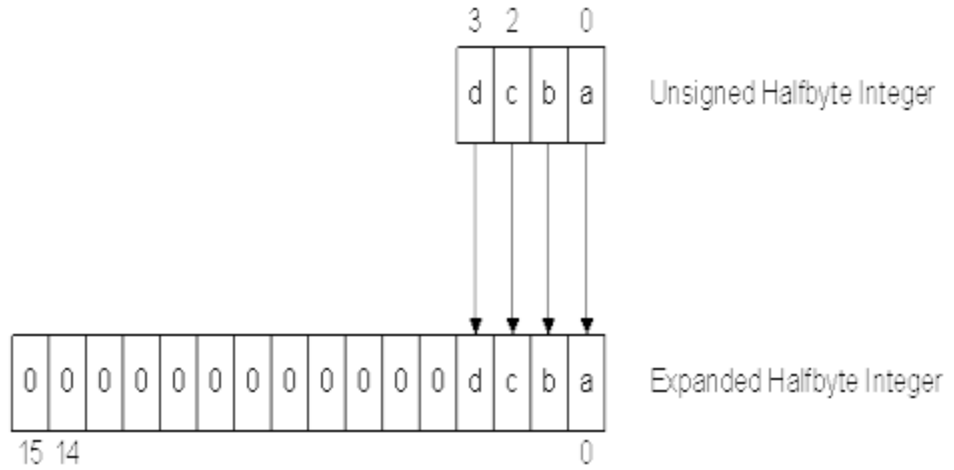

Packed Restricted Float Vector

A packed restricted float vector consists of 4 8-bit restricted floats contained in a doubleword. Each restricted float has the sign at bit 7, a 3-bit coded exponent in bits 4 to 6, a 4-bit fraction in bits 0 to 3, and an implied integer 1. The exponent is in excess-3 format – having a bias of 3. Restricted float provides zero, positive/negative normalized numbers with a small range (3-bit exponent) and small precision (4-bit fraction). This numeric data type is only used by an immediate source operand of doubleword in a GEN instruction. It cannot be used for the destination operand, or a non-immediate source operand.

The following figure shows how to convert an 8-bit restricted float into a single precision float. Converting a 3-bit exponent with a bias of 3 to an 8-bit exponent with a bias of 127 is by adding 4, or equivalently copying bit 2 to bit 7 and putting the inverted bit 2 to bits 6:2. A special logic is also needed to take care of positive/negative zeros.

Conversion from a Restricted 8-bit Float to a Single-Precision Float

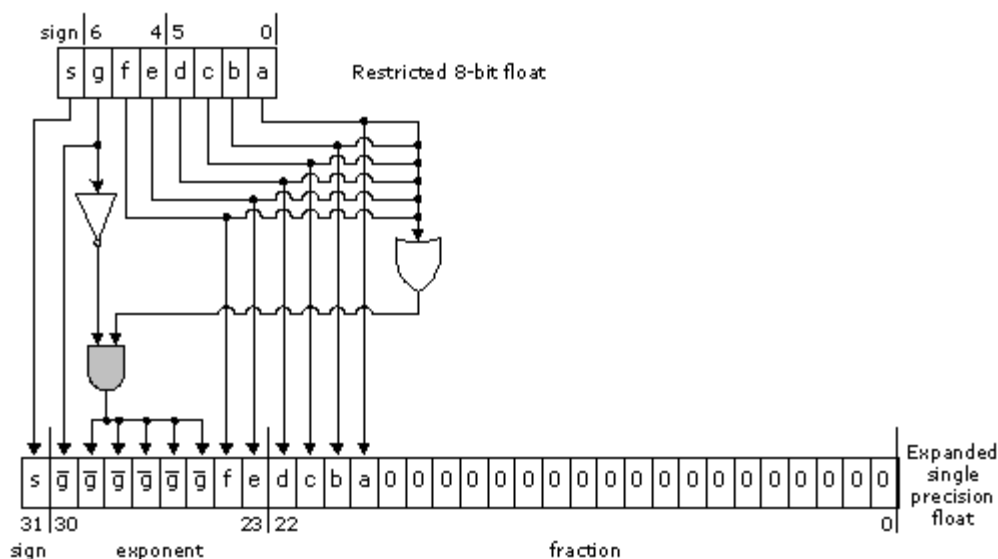

B6886-01

The following table shows all possible numbers of the restricted 8-bit float. Only normalized float numbers can be represented, including positive and negative zero, and positive and negative finite numbers. Normalized infinities, NaN, and denormalized float numbers cannot be represented by this type. It should be noted that this 8-bit floating point format does not follow IEEE-754 convention in describing numbers with small magnitudes. Specifically, when the exponent field is zero and the fraction field is not zero, an implied one is still present instead of taking a denormalized form (without an implied one). This results in a simple implementation but with a smaller dynamic range – the magnitude of the smallest non-zero number is 0.125.

Examples of Restricted 8-bit Float Numbers

Class	Hex #	Sign [7]	Exponent [6:4]	Fraction [3:0]	Extended 8-bit Exponent	Floating Number in Decimal
Positive Normalized Float	0x70-0x7F	0	111	0000 ... 1111	1000 0011	16 ... 31
	0x60-0x6F	0	110	0000 ... 1111	1000 0010	8 ... 15.5
	0x50-0x5F	0	101	0000 ... 1111	1000 0001	4 ... 7.75
	0x40-0x4F	0	100	0000 ... 1111	1000 0000	2 ... 3.875
	0x30-0x3F	0	011	0000 ... 1111	0111 1111	1 ... 1.9375
	0x20-0x2F	0	010	0000 ... 1111	0111 1110	0.5 ... 0.96875
	0x10-0x1F	0	001	0000 ... 1111	0111 1101	0.25 ... 0.484375
	0x01-0x0F	0	000	0001 ... 1111	0111 1100	0.125 ... 0.2421875
	0x00	0	000	0000	0000 0000	0 (+zero)
Negative Normalized Float	0xF0-0xFF	1	111	0000 ... 1111	1000 0011	-16 ... -31
	0xE0-0xEF	1	110	0000 ... 1111	1000 0010	-8 ... -15.5
	0xD0-	1	101	0000 ... 1111	1000 0001	-4 ... -7.75



Class	Hex #	Sign [7]	Exponent [6:4]	Fraction [3:0]	Extended 8-bit Exponent	Floating Number in Decimal
	0xDF					
	0xC0-0xCF	1	100	0000 ... 1111	1000 0000	-2 ... -3.875
	0xB0-0xBF	1	011	0000 ... 1111	0111 1111	-1 ... -1.9375
	0xA0-0xAF	1	010	0000 ... 1111	0111 1110	-0.5 ... -0.96875
	0x90-0x9F	1	001	0000 ... 1111	0111 1101	-0.25 ... -0.484375
	0x81-0x8F	1	000	0001 ... 1111	0111 1100	-0.125 ... -0.2421875
	0x80	1	000	0000	0000 0000	-0 (-zero)

The following figure shows the conversion of a packed exponent-only float to a 4-element vector of single precision floats.

The shorthand format notation for a packed signed half-byte vector is VF.

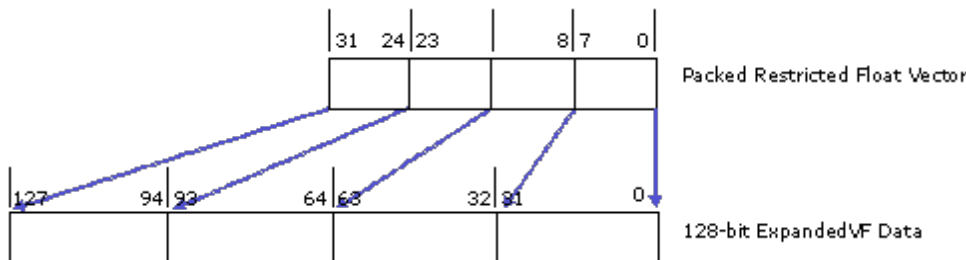

B6889-01...>

Floating Point Modes

GEN architecture supports two floating point operation modes, namely IEEE floating point mode (IEEE mode) and alternative floating point mode (ALT mode). Both modes follow mostly the requirements in IEEE-754 but with different deviations. The deviations will be described in details in later sections. The primary difference between these modes is on the handling of Infs, NaNs and denorms. The IEEE floating point mode may be used to support newer versions of 3D graphics API Shaders and the alternative floating point mode may be used to support early Shader versions. Taking DirectX 3D graphics API Shaders for example, shader models before version 3.0 may use the alternative floating point mode, while version 3.0 and following shader models may use the IEEE floating point mode.

These two modes are supported by all units that perform floating point computations, including GEN execution units, GEN shared functions like Extended Math, the Sampler and the Render Cache color calculator, and fixed functions like VF, Clipper, SF and WIZ. Host software sets floating point mode through the fixed function state descriptors for 3D pipeline and the interface descriptor for media pipeline. Therefore different modes may be associated with different threads running concurrently.



Floating point mode control for EU and shared functions are based on the floating point mode field (bit 0) of *cr0* register.

IEEE Floating Point Mode

Partial Listing of Honored IEEE-754 Rules

Here is a summary of expected 32-bit floating point behaviors in GEN architecture. Refer to IEEE-754 for topics not mentioned.

- $INF - INF = NaN$
- $0 * (+/-)INF = NaN$
- $1 / (+INF) = +0$ and $1 / (-INF) = -0$
 - $(+/-)INF / (+/-)INF = NaN$ as $A/B = A * (1/B)$
- $INV (+0) = RSQ (+0) = +INF$, $INV (-0) = RSQ (-0) = -INF$, and $SQRT (-0) = -0$
- $RSQ (-finite) = SQRT (-finite) = NaN$
- $LOG (+0) = LOG (-0) = -INF$, $LOG (-finite) = LOG (-INF) = NaN$
- NaN (any OP) any-value = NaN with one exception for min/max mentioned below. Resulting NaN may have different bit pattern than the source NaN .
- Normal comparison with conditional modifier of EQ, GT, GE, LT, LE, when either or both operands is NaN , returns FALSE. Normal comparison of NE, when either or both operands is NaN , returns TRUE.
 - **Note:** Normal comparison is either a **cmp** instruction or an instruction with conditional modifier
- Special comparison **cmpn** with conditional modifier of EQ, GT, GE, LT, LE, when the second source operand is NaN , returns TRUE, regardless of the first source operand, and when the second source operand is not NaN , but first one is, returns FALSE. **Cmpn** of NE, when the second source operand is NaN , returns FALSE, regardless of the first source operand, and when the second source operand is not NaN , but first one is, returns TRUE.
 - This is used to support the proposed IEEE-754R rule on **min** or **max** operations. For which, if only one operand is NaN , min and max operations return the other operand as the result.
- Both normal and special comparisons of any non- NaN value against $+/- INF$ return exact result according to the conditional modifier. This is because that infinities are exact representation in the sense that $+INF = +INF$ and $-INF = -INF$.
 - NaN is unordered in the sense that $NaN != NaN$.
- IEEE-754 requires floating point operations to produce a result that is the nearest representable value to an infinitely precise result, known as "round to nearest even" (RTNE). 32-bit floating point



operations must produce a result that is within 0.5 Unit-Last-Place (0.5 ULP) of the infinitely precise result. This applies to addition, subtraction, and multiplication.

- All arithmetic floating point instructions does Round To Nearest Even at the end of the computation, except the round instructions.

Complete Listing of Deviations or Additional Requirements vs. IEEE-754

For a result that cannot be represented precisely by the floating point format, the EU uses rounding to nearest or even to produce a result that is within 0.5 Unit-Last-Place(0.5 ULP) of the infinitely precise result.

The rounding mode is specified by the Rounding Mode field in the Control Register.

The EU can report floating point overflow and NaN into conditional flags. However, there is no support for floating point exceptions, status bits, or traps.

Denorms are handled as follows:

- Single precision (F, Float) denorms are flushed to sign-preserved zero on input and output of any floating-point mathematical operation.
- Double precision (DF, Double Float) denorms are kept or flushed in mathematical operations based on the Double Precision Denorm Mode in the Control Register.
- Denorms are not flushed for format conversions, irrespective of any denorm mode.
- Denorms are not flushed for raw *mov* operations. For information about raw *mov* operations, refer to the **Description** in **Instruction Move EUISA**.
- Input denorms are not flushed for half precision to single precision floating-point conversion.

Other information regarding floating-point behaviors:

- NaN input to an operation always produces NaN on output, however the exact bit pattern of the NaN is not required to stay the same (unless the operation is a raw *mov* instruction which does not alter data at all.)
- $x * 1.0f$ must always result in x (except denorm flushed and possible bit pattern change for NaN).
- $x +/- 0.0f$ must always result in x (except denorm flushed and possible bit pattern change for NaN). But $-0 + 0 = +0$.
- Fused operations (such as *mac*, *dp4*, *dp3*, etc.) may produce intermediate results out of 32-bit float range, but whose final results would be within 32-bit float range if intermediate results were kept at greater precision. In this case, implementations are permitted to produce either the correct result, or else $\pm inf$. Thus, compatibility between a fused operation, such as *mac*, with the unfused equivalent, *mul* followed by *add* in this case, is not guaranteed.
- As the accumulator registers have more precision than 32-bit float, any instruction with accumulator as a source/destination operand may produce a different result than that using GRF registers.



- API Shader divide operations are implemented as $x*(1.0f/y)$. With the two-step method, $x*(1.0f/y)$, the multiply and the divide each independently operate at the 32-bit floating point precision level (accuracy to 1 ULP).
- See the **Type Conversion** section for rules on converting to and from float representations.

Comparison of Floating Point Numbers

The following tables detail the rules for floating point comparison. In the tables, +/-Fin stands for a positive or negative finite precision floating point number. Result is either a true (T) or false (F). Each row corresponds to a fixed src0 and each column corresponds to a fixed src1. When comparing two positive finite numbers (or two negative finite numbers), the result can be T or F depending on the values. Therefore, the corresponding fields in the following tables are marked as T/F. When comparing two double float numbers, the result can be T or F depending on the values and the denorm mode (enabled/disabled). The corresponding fields in the following tables are marked T/F*.

Results of Greater-Than Comparison – CMP.

src0 src1	-inf	-Fin	-denorm	-0	+0	+denorm	+Fin	+inf	NaN
-inf	F	F	F	F	F	F	F	F	F
-Fin	T	T/F	F	F	F	F	F	F	F
-denorm	T	T	T/F*	F	F	F	F	F	F
-0	T	T	T/F*	F	F	F	F	F	F
+0	T	T	T/F*	F	F	F	F	F	F
+denorm	T	T	T/F*	T/F*	T/F*	T/F*	F	F	F
+Fin	T	T	T	T	T	T	T	T/F	F
+inf	T	T	T	T	T	T	T	T	F
NaN	F	F	F	F	F	F	F	F	F

Results of Less-Than Comparison – CMP.L

src0 src1	-inf	-Fin	-denorm	-0	+0	+denorm	+Fin	+inf	NaN
-inf	F	T	T	T	T	T	T	T	F
-Fin	F	T/F	T	T	T	T	T	T	F
-denorm	F	F	T/F*	T/F*	T/F*	T/F*	T	T	F
-0	F	F	F	F	F	T/F*	T	T	F
+0	F	F	F	F	F	T/F*	T	T	F



src0	src1	-inf	-Fin	-denorm	-0	+0	+denorm	+Fin	+inf	NaN
+denorm		F	F	F	F	F	T/F*	T	T	F
+Fin		F	F	F	F	F	F	T/F	T	F
+inf		F	F	F	F	F	F	F	F	F
NaN		F	F	F	F	F	F	F	F	F

Results of Equal-To Comparison – CMP.E

src0	src1	-inf	-Fin	-denorm	-0	+0	+denorm	+Fin	+inf	NaN
-inf		T	F	F	F	F	F	F	F	F
-Fin		F	T/F	F	F	F	F	F	F	F
-denorm		F	F	T/F*	T/F*	T/F*	T/F*	F	F	F
-0		F	F	T/F*	T	T	T/F*	F	F	F
+0		F	F	T/F*	T	T	T/F*	F	F	F
+denorm		F	F	T/F*	T/F*	T/F*	T/F*	F	F	F
+Fin		F	F	F	F	F	F	T/F	F	F
+inf		F	F	F	F	F	F	F	T	F
NaN		F	F	F	F	F	F	F	F	F

Results of Not-Equal-To Comparison – CMP.NE

src0	src1	-inf	-Fin	-denorm	-0	+0	+denorm	+Fin	+inf	NaN
-inf		FALSE	T	T	T	T	T	T	T	T
-Fin		T	T/F	T	T	T	T	T	T	T
-denorm		T	T	T/F*	T/F*	T/F*	T/F*	T	T	T
-0		T	T	T/F*	FALSE	FALSE	T/F*	T	T	T
+0		T	T	T/F*	FALSE	FALSE	T/F*	T	T	T
+denorm		T	T	T/F*	T/F*	T/F*	T/F*	T	T	T
+Fin		T	T	T	T	T	T	T/F	T	T
+inf		T	T	T	T	T	T	T	FALSE	T
NaN		T	T	T	T	T	T	T	T	T

Results of Less-Than Or Equal-To Comparison – CMP.LE

src0	src1	-inf	-Fin	-denorm	-0	+0	+denorm	+Fin	+inf	NaN
-inf		T	T	T	T	T	T	T	T	F
-Fin		F	T/F	T	T	T	T	T	T	F



src0	src1	-inf	-Fin	-denorm	-0	+0	+denorm	+Fin	+inf	NaN
-denorm		F	F	T/F*	T/F*	T/F*	T/F*	T	T	F
-0		F	F	T/F*	T	T	T/F*	T	T	F
+0		F	F	T/F*	T	T	T/F*	T	T	F
+denorm		F	F	T/F*	T/F*	T/F*	T/F*	T	T	F
+Fin		F	F	F	F	F	F	T/F	T	F
+inf		F	F	F	F	F	F	F	T	F
NaN		F	F	F	F	F	F	F	F	F

Results of Greater-Than or Equal-To Comparison – CMP.GE

src0	src1	-inf	-Fin	-denorm	-0	+0	+denorm	+Fin	+inf	NaN
-inf		T	F	F	F	F	F	F	F	F
-Fin		T	T/F	F	F	F	F	F	F	F
-denorm		T	T	T/F*	T/F*	T/F*	T/F*	F	F	F
-0		T	T	T/F*	T	T	T/F*	F	F	F
+0		T	T	T/F*	T	T	T/F*	F	F	F
+denorm		T	T	T/F*	T/F*	T/F*	T/F*	F	F	F
+Fin		T	T	T	T	T	T	T/F	F	F
+inf		T	T	T	T	T	T	T	T	F
NaN		F	F	F	F	F	F	F	F	F

Min Max of Floating Point Numbers

A special comparison called Compare-NaN is introduced in the GEN architecture to handle the difference of above mentioned floating-point comparison and the rules on supporting MIN/MAX. To compute the MIN or MAX of two floating-point numbers, if one of the numbers is NaN and the other is not, MIN or MAX of the two numbers returns the one that is not NaN. When two numbers are NaN, MIN or MAX of the two numbers returns source1.

Min and Max is supported by conditional select.

Note even though f0.0 is specified in the instruction, the flag register is not touched by this instruction.

The following tables detail the rules for this special compare-NaN operation for floating-point numbers. Notice that excepting "Not-Equal-To" comparison-NaN, last columns in all other tables have 'T'.

Alternative Floating Point Mode

The key characteristics of the alternative floating point mode is that NaN, Inf, and denorm are not expected for an application to pass into the graphics pipeline, and the graphics hardware must not generate NaN, Inf, or denorm as computation result. For example, a result that is larger than the maximum representable floating point number is expected to be flushed to the largest representable



floating point number, i.e., +fmax. The fmax has an exponent of 0xFE and a mantissa of all one's, which is the same for IEEE floating point mode.

Note that this mode is applicable ONLY to Single Precision Float datatype.

This also implies that ALT mode is not supported when Single precision datatype is involved in format conversion to double precision or half precision.

Here is the complete list of the differences of legacy graphics mode from the relaxed IEEE-754 floating point mode.

- Any +/- INF result must be flushed to +/- fmax, instead of being output as +/- INF.
- Extended mathematics functions of log(), rsq(), and sqrt() take the absolute value of the sources before computation to avoid generating INF and NaN results.

Alternative Floating Point Mode shows the support of these differences in various hardware units.

Supported Legacy Float Mode and Impacted Units

IEEE-754 Deviations	VF	Clipper	SF	WIZ	EU	EM	Sampler	RC
Any +/- INF result flushed to +/- fmax	Y	Y	Y	Y	Y	Y	Y	Y
Log, rsq, sqrt take abs() of sources	N/A	N/A	N/A	N/A	N/A	Y	N/A	N/A

Alternative Floating Point Mode shows some of the desired or recommended alternative floating point mode behaviors that do not have hardware design impact. The reasons of not needing special hardware support for these items are also provided. This is based on the compliance requirement that can be found in the DirectX 9 specification: **Handling of NaNs, Infs, and denorms is undefined. Applications should not pass in such values into the graphics pipeline.**

Dismissed Legacy Behaviors

Suggested IEEE-754 Deviations	Reason for Dismiss
Mov forces (+/-)INF to (+/-)fmax	(+/-)INF is never present as input
(+/-)INF - (+/-)INF = +/- fmax instead of NaN	(+/-)INF is never present as input
Denorm must be flushed to zero in all cases (including trivial mov and point sampling)	Denorm is never present as input
Anything*0=0 (including NaN*0=0 and INF*0=0)	NaN and INF are never present as input
Except propagated NaN, NaN is never generated	NaN is never present as input and GEN never generates NaN based on rules in the previous table
An input NaN gets propagated excepting (a)-(d)	NaN is never present as input
(a) Rcp (and rsq) of 0 yields fmax	N/A, as it is already covered by the general rule <i>Any +/- INF result flushed to +/- fmax</i>
(b) Sampler honors 0/0 = 0 as if (1/0)*0	There is no divide in Sampler
I Rcp (and rsq) of INF yields +/- 0	(+/-)INF is never present as input



Suggested IEEE-754 Deviations	Reason for Dismiss
(d) Sampler honors $INF/INF = 0$ as if $(1/INF)=0$ followed by $Anything*0 = 0$	There is no divide in Sampler



Type Conversion

Float to Integer

Converting from float to integer is based on rounding toward zero (RTZ is for DX, IEEE expects all four rounding modes). If the floating point value is +0, -0, +Denorm, -Denorm, +NaN or -NaN, the resulting integer value is always 0. If the floating point value is positive infinity (or negative infinity), the conversion result takes the largest (or the smallest) represent-able integer value. If the floating point value is larger (or smaller) than the largest (or the smallest) represent-able integer value, the conversion result takes the largest (or the smallest) represent-able integer value. The following table shows these special cases. The last two rows are just examples. They can be any number outside the represent-able range of the output integer type (UD, D, UW, W, UB and B).

Input Format	Output Format					
	UD	D	UW	W	UB	B
+/- Zero	00000000	00000000	00000000	00000000	00000000	00000000
+/- Denorm	00000000	00000000	00000000	00000000	00000000	00000000
NAN	00000000	00000000	00000000	00000000	00000000	00000000
-NAN	00000000	00000000	00000000	00000000	00000000	00000000
INF	FFFFFFFF	7FFFFFFF	0000FFFF	00007FFF	000000FF	0000007F
-INF	00000000	80000000	00000000	00008000	00000000	00000080
+2 ³² (*)	FFFFFFFF	7FFFFFFF	0000FFFF	00007FFF	000000FF	0000007F
-2 ³² -1 (*)	00000000	80000000	00000000	00008000	00000000	00000080

Integer to Integer with Same or Higher Precision

Converting an unsigned integer to a signed or an unsigned integer with higher precision is based on zero extension.

Converting an unsigned integer to a signed integer with the same precision is based on modular wrap-around. Without saturation, a larger than represent-able number becomes a negative number. With saturation, a larger than represent-able number is saturated to the largest positive represent-able number.

Converting a signed integer to a signed integer with higher precision is based on sign extension.

Converting a signed integer to an unsigned integer with higher precision is based on sign extension. Without saturation, a negative number becomes a large positive number with the sign bit wrapped-up. With saturation, a negative number is saturated to zero.



Integer to Integer with Lower Precision

Converting a signed or an unsigned integer to a signed or an unsigned integer with lower precision is based on bit truncation. Without saturation, only the lower bits are kept in the output regardless of the sign-ness of input and output. With saturation, a number that is outside the represent-able range is saturated to the closest represent-able value.

Integer to Float

Converting a signed or an unsigned integer to a single precision float number is to round to the closest representable float number. For any integer number with magnitude less than or equal to 24 bits, resulting float number is a precise representation of the input. However, if it is more than 24 bits, by default a "round to nearest even" is performed.

Double Precision Float to Single Precision Float

Double Precision Float	Single Precision Float
-inf	-inf
-finite	-finite/-denorm/-0
-denorm	-0
-0	-0
+0	+0
+denorm	+0
+finite	+finite/+denorm/+0
+inf	+inf
NaN	NaN

The upper Dword of every Qword will be written with undefined value when converting DF to F.

Single Precision Float to Double Precision Float

Converting a single precision floating-point number to a double precision floating-point number will produce a precise representation of the input.

Single Precision Float	Double Precision Float
------------------------	------------------------



Single Precision Float	Double Precision Float
-inf	-inf
-finite	-finite
-denorm	-finite
-0	-0
+0	+0
+denorm	+finite
+finite	+finite
+inf	+inf
NaN	NaN



Exceptions

The GEN Architecture defines a basic exception handling mechanism for several exception cases. This mechanism supports both normal operations such as extensions of the mask-stack depth, as well as detecting some illegal conditions .

Exception Types

Type	Trigger / Source	Sync/Async Recognition
Software Exception	Thread code	Synchronous
Breakpoint	<ul style="list-style-type: none">• A bit in the instruction word• Breakpoint IP match• Breakpoint Opcode match	Synchronous
Illegal Opcode	Hardware	Synchronous
Halt	MMIO register write	Asynchronous
Context Save/Restore	Preemption Interrupt	Asynchronous

Threads may choose which exceptions to recognize and which to ignore. This mask information is specified on a per-kernel basis in fixed function state generated by the driver, and delivered to the EU as part of a new thread dispatch. Upon arrival at the EU, the exception-mask information is used to initialize the exception enable fields of that thread's cr0.1 register, which controls exception recognition. This register is instantiated on a per-thread basis, allowing independent control of exception type recognition across hardware threads. The exception enable bits in the cr0.1 register are read/write, and thus can be enabled/disabled via software at any time during thread execution.

The exception handling mechanism relies on the System Routine, a single subroutine that provides common exception handling for all threads on all EUs in the system. This System Routine is defined per-context and is identified via a System IP (SIP) register in context state. At the time of each context switch, the appropriate SIP for that context is loaded into each EU, allowing each context to have custom implementation of exception handling routines if so desired.

The mechanism does not support handling recursive system routine access. This means when a thread cannot be asynchronously interrupted to an exception when executing a SIP.

Example:

An Exception is not supported when hardware is executing a SIP for context save and restore operations.



Exception-Related Architecture Registers

Exception-related registers are architecture registers cr0.0 through cr0.2. These registers are instantiated on a per-thread basis providing each hardware thread with unique control over exception recognition and handling. The registers provide the capability to mask exception types, determine the type of raised exception, store the return address, and control exiting from the System Routine back to the application thread.

Many of the bits in these registers are manipulated by both hardware and software. In all cases, the read/write operations by hardware and software occur at exclusive times in a thread's lifetime, thus there is no need for atomic read-modify-write operations when accessing these registers.



System Routine

The following diagram illustrates the basic flow of exception handling and the structure of the System Routine.

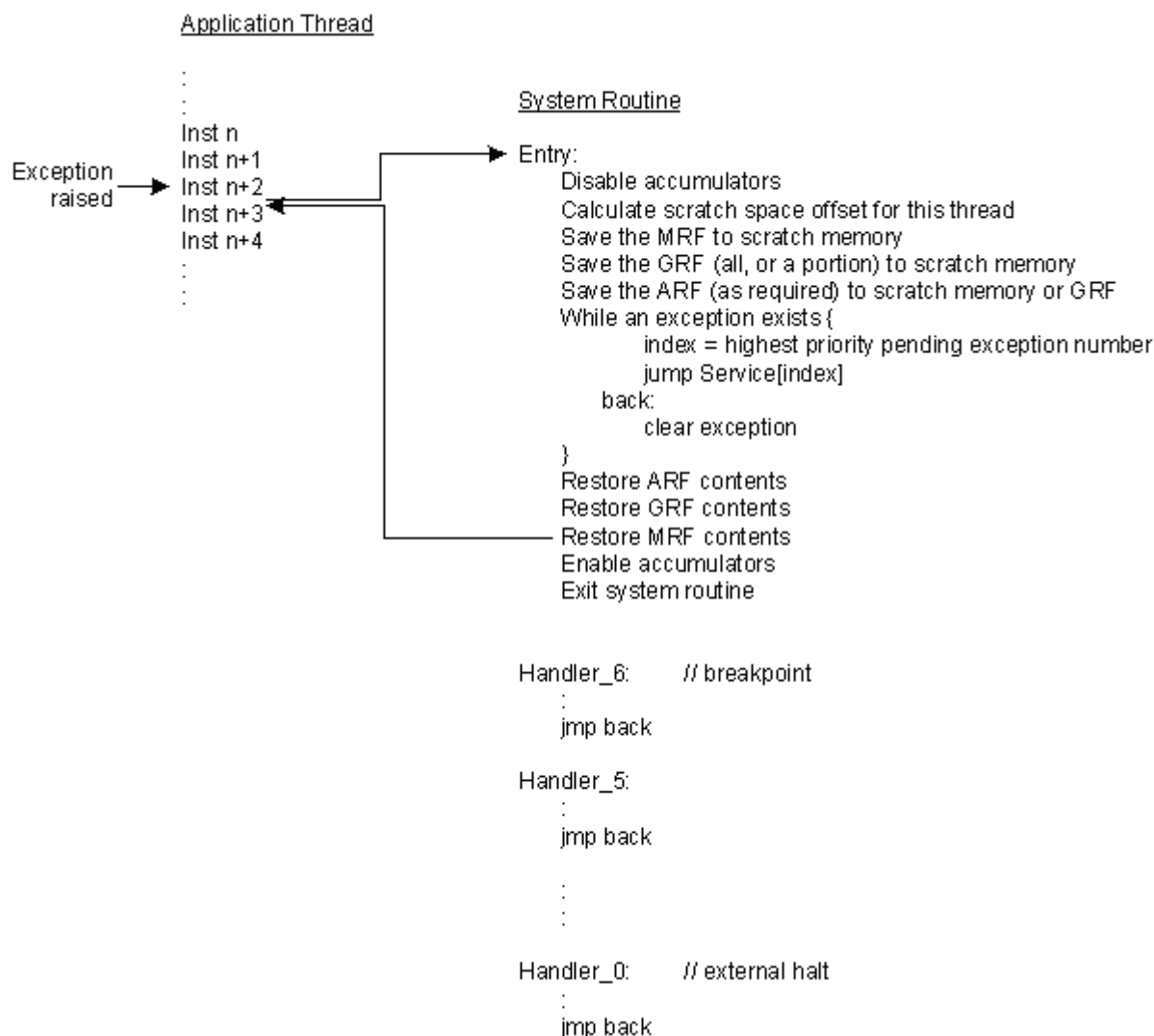

Invoking the System Routine

The System Routine is invoked in response to a raised exception. Once an exception is raised, no further instructions from the application thread are issued until the System Routine has executed and returned control back to the application thread.

After an exception is recognized by hardware, the EU saves the thread's IP into its AIP register (cr0.2), and then moves the System Routine offset, SIP, into the thread's IP register. At this point the next instruction issued for that thread is the first instruction of the System Routine.



The System Routine maintains the same execution priority, GRF register space, and thread state as the application thread from which it is invoked. Due to assuming the same priority, there may be significant absolute time between an exception being raised and invoking the System Routine, as other higher priority threads within the EU continue to execute. From a thread's perspective, once an exception is recognized, the next instruction issued is from the System Routine.

At the time of System Routine invocation, there may still be outstanding registers in-flight from the application thread. Depending on the instruction sequence in the System Routine, an in-flight register may be referenced by the System Routine and cause a register-in-flight dependency. These dependencies are honored by the System Routine and may cause the System Routine to be suspended until the register retires.

Exception processing is not nested within the System Routine. If a future exception is detected while executing the System Routine, the exception is latched into cr0.1, but does not cause a nested re-invocation of the System Routine. The exception recognition hardware recognizes only one outstanding exception of each type; i.e., once a specific exception type is detected and latched in cr0.1, and until the exception is cleared, any further exception of that type is lost.

Accumulators are not natively preserved across the System Routine. To make sure the accumulators are in the identical state once control is returned to the application thread, the System Routine must either set the Accumulator Disable bit of cr0.0 before using any instruction that modifies an accumulator, or save and restore the accumulators (using GRF registers or system thread scratch memory) around the System Routine. Saving and restoring accumulators, including their extended precision bits, can be accomplished by a short series of moves and shifts of the accumulator register. Also note that the state of the Accumulator Disable bit itself must be preserved unless, by convention, the driver software limits its manipulation to only the System Routine.

Further, upon System Routine entry, the execution-related masks (Continue, Loop, If, and Active masks, contained in the Mask Register) will remain set as they were in the application thread. Thus only a subset of channels may be active for execution. To enable execution on all channels, the System Routine may choose to use the instruction option *NoMask*, or may choose to set the mask registers to the desired value so long as it saves/restores the original masks upon System Routine entry/exit.

Similarly there is no hardware mechanism to preserve flags, mask-stacks, or other architecture registers across the System Routine. The System Routine must ensure that these values are preserved (see the *Conditional Instructions Within the System Routine* section for related information).

Returning to the Application Thread

Prior to returning control to the application thread, the System Routine should clear the proper Exception Status and Control bit in cr0.1. Failure to do so forces the thread's execution to reenter the System Routine before any further instructions are executed from the application thread. (Note that single-stepping functionality is the one exception where the exception's Status and Control bit is not reset before exit.)



The System Routine may choose to loop within a single invocation of the System Routine until all pending exceptions are serviced, or may choose to service exceptions one at a time (a simpler solution, but less efficient).

The System Routine is exited, and control returned to the application thread, via a write to the Master Exception State and Control bit in cr0.0. Upon clearing this bit, the value of AIP (cr0.2) is restored to the thread's IP register and, with no further exceptions pending, execution resumes at that address. The System Routine must follow any write to the Master Exception State and Control bit with at least one SIMD-16 *nop* instruction to allow control to transition. Throughout the System Routine, the AIP register maintains its value at the time the exception was raised unless directly modified by the System Routine. (See the AIP register definition for specifics on the IP value saved to AIP).

System IP (SIP)

The System IP (SIP) is the 16 byte-aligned offset of the first instruction of the System Routine, relative to the General State Base Address. SIP is assigned by the STATE_SIP command to the command streamer which updates SIP in the EU.

When the System Routine is invoked, the application thread's current IP is first saved into the AIP field of cr0.2. The SIP address is then loaded into the thread's IP register and execution continues within the System Routine. Thus each invocation of the System Routine has a common entry point. Returning from the System Routine loads IP from AIP, continuing thread execution.

System Routine Register Space

The System Routine uses the same GRF space as the thread that invokes it. As such all of the calling thread's registers and their contents are visible to the System Routine. Further, the System Routine must only use r0..r15 of the GRF, as a minimal thread may have requested and been allocated this few. If the System Routine requires more registers than this, the driver should establish a higher minimum allocation for all threads.

The System Routine may encounter any residual register dependencies of the calling thread until such time that they clear by the return of in-flight writebacks.

No persistent storage is automatically allocated to the System Routine, although a driver implementation may set aside part of system scratch memory for the System Routine.

Any parameter passing to the System Routine (for use by software exceptions) is done via the GRF based on system thread/application thread convention.

Conditional Instructions Within the System Routine

It is expected that most, if not all, control flow within the System Routine is scalar in nature. If so, the System Routine should set SPF (Single Program Flow, cr0.0) to enable scalar branching. In this mode, conditional/loop instructions do not update the mask stacks and therefore do not have restrictions on their use nor require the save/restore of hardware mask stack registers.



If SIMD branching is desired within the System Routine, special considerations must be taken. Upon entry to the System Routine, the depth of the mask stacks is unknown at that point, and may be near full. If so, a subsequent conditional instruction and its associated mask *push* may cause a stack overflow. This would generate an exception within the system routine, an unsupported occurrence. To prevent this, if the System Routine uses SIMD conditional instructions, it must save the mask stacks prior to the first SIMD conditional instruction, and restore them after the last SIMD conditional instruction. As a general solution, it may be easiest to simply implement the save/restore as part of the entry/exit code sequence, using an available GRF register pair as a storage location. Once saved, the stacks should be reset to their empty condition, namely depth = 0 and top of stack = 0xFFFFFFFF.

Use of NoDDClr

The GEN instruction word defines an instruction option **NoDDClr** that overrides the native register dependency clearing mechanism of the typical instruction. When specified, NoDDClr does not clear, at register writeback time, the dependency placed on the destination register of the instruction. Use of this mechanism may provide increased performance when a kernel can guarantee no dependency issues between instructions, but may cause issues with exception handling in some circumstances as discussed here.

Typically NoDDClr is used in an instruction series to enable a sequence of writes to sub-fields of a GRF register without paying a dependency penalty on each instruction. In this case, NoDDClr and NoDDChk are used across an instruction sequence to allow the first instruction to set the destination dependency, interior instructions to write to the GRF register without dependency checks, and the last instruction to clear the dependency. (This sequence is referred to as a NoDDClr code block going forward). By only allowing the last instruction to clear the dependency, program execution is prevented from going beyond a certain point until all writes of that sequence are known to retire.

The problem arises if an exception is raised within a NoDDClr code block. In this case, there exists the potential for the System Routine to hang while attempting to save/restore a register used as a destination register by the NoDDClr code block, as the outstanding dependency on that register will not clear until the final instruction of the NoDDClr block is executed, sometime after the System Routine returns. Should the System Routine attempt to use that register, it hangs waiting on a dependency to be cleared by an instruction not yet issued.

Note: This is a known condition and will in some cases not allow the full GRF contents to be externally visible in System Routine scratch space during a break or halt exception.

To avoid this condition, guidelines are provided below for consideration. (Note that these are general guidelines, some of which can be alleviated through careful coding and register usage conventions and restrictions.)

- NoDDClr code blocks should only be used where absolutely necessary.
- Instructions that may generate exceptions should not be placed within NoDDClr blocks. This includes most conditional branch instructions (if, do, while, ...).
- If possible, use NoDDClr on registers high in the thread's register allocation (e.g. r120), thus even if a System Routine hang occurs, as much of the GRF is visible as possible. (Note that this would also



require the System Routine to update the progress of the GRF dump, perhaps with each GRF block written, or to initialize the System Routine's scratch space to a known value, to be able to distinguish valid/locations from unwritten locations).

Also a driver implementation may consider a disable-NoDDClr option in which jitted code does not use the NoDDClr capability. In this case, there is no change to the code that is jitted other than removal of the NoDDClr instruction option. The code executes as normal, but with a higher number of thread switches in what would have been a NoDDClr code block.



Exception Descriptions

This section describes conditions that can cause exceptions and transfer control to the System Routine.

Illegal Opcode

The GEN ISA defines a single *illegal* opcode. The byte value of the *illegal* opcode is 0x00 due to it being a likely byte value encountered by a wayward instruction pointer value. The *illegal* instruction signals an exception if exception handling is enabled and invokes the system interrupt routine. If exception handling is NOT enabled, the illegal opcode is executed resulting in undetermined behavior including a system hang. Hardware decodes all legal opcodes supported. Any byte value that is not in the legal opcode list is decoded as an illegal opcode to trigger exception.

Undefined Opcodes

All undefined opcodes in the 8-bit opcode space (which includes instruction bit 7, reserved for future opcode expansion) are detected by hardware. If an undefined opcode is detected, the opcode is overridden by hardware, forcing the opcode value within the pipeline to the defined *illegal* opcode. The offending instruction, should it eventually be issued down the execution unit's pipeline, generates an Illegal Opcode exception as described in the section *Illegal Opcode*. The memory location of the offending opcode keeps its original value. That location can be queried to determine the opcode value.

Software Exception

A mechanism is provided to allow an application thread to invoke an exception and is triggered using the Software Exception Set and Clear bit of cr0.1. Sub-function determination and parameter passing into and out of the exception handler is left to convention between the system-thread and application-thread. The thread's IP is incremented before saving AIP and entering the System Routine, causing execution to resume at the next application-thread instruction after returning from the System Routine.

Context Save and Restore

The System Routine is also used to save and restore the context of the Execution Unit. This feature is enabled in GPGPU workloads *only*.

When the execution engine receives a preemption or an interrupt, the application thread invokes the System Routine. The System Routine is invoked only when all in-flight registers have retired. The system routine is used to save all the state of the EU to memory. When the sequence is complete, the master exception control bit is cleared. This action stops all execution for the given thread and invalidates the thread. This means a new thread from a different context may be loaded. When the master exception control bit is cleared, software must ensure that all outstanding messages from the EU are dispatched out of the execution message pipeline. This is achieved by creating a dependency on the last send that is saving EU state. A dummy instruction before clearing the master exception control bit ensures that this is achieved.



The System Routine is also invoked on a context restore request. In this case a dummy thread is loaded into the EU which starts with the System Routine. This routine now restores the state of the EU. The restore sequence used in such a case should be consistent with the save sequence to ensure that state is restored correctly. After completing the restore sequence, the System Routine must clear the master exception control bit in the Control Register. This enables hardware to switch to the application thread which continues execution.



Events That Do Not Generate Exceptions

The conditions described in this section are either not recognized or do not generate an exception.

Illegal Instruction Format

This condition includes malformed instructions in which the opcode is legal, but the source or destination operands or other instruction attributes do not comply with the instruction specification. There is no direct hardware support to detect these cases and the outcome of issuing a malformed instruction is undefined.

Note that GEN does not support self-modifying code, therefore the driver has an opportunity to detect such cases before the thread is placed in service.

Malformed Message

A message's contents, destination registers, lengths, and descriptors are not interpreted in any way by the execution unit. Errors in specifying message fields do not raise exceptions in the EU but may be detected and reported by the shared functions.

GRF Register Out of Bounds

Unique GRF storage is allocated to each thread which, at a minimum, satisfies the register requirements specified in the thread's declaration. References to GRF register numbers beyond that called for in the thread's declaration do not generate exceptions. Depending on the implementation, out-of-bounds register numbers may be remapped to r0..r15, although this functionality should not be relied upon by the thread. The hardware guarantees the isolation of each thread's register space, thus there is no possibility of direct register manipulation via an out-of-bounds register access.

Hung Thread

There is no hardware mechanism in the EU to detect a hung thread and such a thread may remain hung indefinitely. It is expected that one or more hung threads will eventually cause the driver to recognize a context timeout and take appropriate recovery action.

Instruction Fetch Out of Bounds

The EU implements a full 32-bit instruction address range (with the 4 LSBs don't care), making it possible for a thread to attempt to jump to any 16-byte aligned offset in the 32-bit instruction address range. (Instruction addresses are offsets from the General State Base Address.) The EU does not provide any type of address checking on instruction fetch requests sent to the memory/cache hierarchy, although error conditions for memory addresses are reported via the Page Table Error Register and other memory interface registers.



FPU Math Errors

The EU's floating point units (FPUs) have defined behaviors for traditional floating point errors and do not generate exceptions. There is no support for signaling FPU math errors as exceptions.

Computational Overflow

Depending on source operand types and values, destination type, and the operation being performed, overflows may occur in the execution pipelines. Many instructions support the overflow (**.o**) conditional modifier that assigns flag bits based on whether or not an overflow occurs.

The EU never signals exceptions for overflows. Software must provide any overflow handling.



Instruction Set Summary

Instruction Set Characteristics

SIMD Instructions and SIMD Width

GEN instructions are SIMD (single instruction multiple data) instructions. The number of data elements per instruction, or the execution size, depends on the data type. For example, the execution size for GEN instructions operating on 256-bit wide vectors can be up to 8 for 32-bit data types, and be up to 16 for 16-bit data. The maximum execution size for GEN instructions for 8-bit data types is also limited to 16.

An instruction compression mode is supported for 32-bit instructions (including mixed 32-bit and 16-bit data computation). A compressed GEN instruction works on twice as much SIMD data as that for a non-compressed GEN instruction. A compressed instruction is converted into two native instructions by the instruction dispatcher in the EU.

GEN instructions are executed on a narrower SIMD execution pipeline. Therefore, GEN native instructions take multiple execution cycles to complete. See *SIMD Instructions and SIMD Width* for parameters for difference device hardware.

Instruction Operands and Register Regions

Most GEN instructions may have up to three operands, two sources and one destination. Each operand is able to address a register region. Source operands support negate and absolute modifier and channel swizzle, and the destination operand supports channel mask.

Dual destination instructions are also supported (four-operand instructions in a general sense): One case is for the implied destination – flag register, where the conditional modifiers and the predicate modifiers may apply. Another case is the message header creation (implied move or implied assembling of the header) in the *send* instruction.

Each execution channel contains an accumulator that is wider than the input data to support back-to-back accumulation operations with increased precision. The added precision (see accumulator register description in Execution Environment chapter) determines the maximum number of accumulations before possible overflow. The accumulator can be pre-loaded through the use of *mov*. It can also be pre-loaded by arithmetic instructions such as *add* or *mul*, since the result of these instructions can go to the accumulator. The accumulator registers are per thread and therefore safe for thread switching.

Register access can be direct or register-indirect. Register-indirect register access uses address registers plus an immediate offset term to compute the register addresses, and only applies to the first source operand (*src0*) and/or the destination operand.

There is one address register. [HSW]: There are 8 address sub-registers. Each sub-register contains a 16-bit unsigned value. The leading two sub-registers form a special doubleword that can be used as the descriptor for the *send* instruction.



Source operand can also be immediate value (also referred to as inline constants). For instructions with two source operands, only the second operand `src1` is allowed to be immediate. For instructions with only one source operand, the source operand `src0` is used and it can be an immediate.

An immediate source operand can be a scalar value of specified type up to 32-bit wide, which is replicated to create a vector with length of Execution Size. An immediate operand can also be a special 32-bit vector with 8 elements each of 4-bit signed integer value, or a 32-bit vector with 4 elements each of 8-bit restricted float value.

Instruction Execution

It is implied that all instructions operate across all channels of data unless otherwise specified either via destination mask, predication, execution mask (caused by SIMD branch and loop instructions), or execution size.

Instruction execution size can be specified per instruction, from scalar (*ExecSize* = 1) up to the maximal execution size supported for the data type, with the restriction that execution size can only be in power of 2.

Instruction Machine Formats

This section shows the machine formats of the GEN instruction set. The instructions in the GEN architecture have a fixed length of 128 bits in the native format. A compact format, discussed separately in this volume, can represent some instructions using 64 bits. Out of the 128 bits in the native format, there are 120 bits in use, and the remaining bits are reserved for future extensions. One instruction consists of instruction fields that control various stages of execution. These fields are roughly grouped into the 4 DWords as follows:

- Instruction Operation Doubleword (DW0) contains the Opcode and other general instruction control fields.
- Instruction Destination Doubleword (DW1) specifies the destination operand (`dst`) and the register file and type of source operands.
- Instruction Source 0 Doubleword (DW2) contains the first source operand (`src0`).
- Instruction Source 1 Doubleword (DW3) contains the second source operand (`src1`) and is used to hold any 32-bit immediate source (`imm32` as `src0` or `src1`).

Most instructions have 1 or 2 source operands and use a common instruction format. Within that format, there are variations based on `AddrMode` and `AccessMode`. There is a separate instruction format for a small number of instructions with 3 source operands. `Send`, `math`, and branching instructions have format variations described separately.

The 3-source instructions have the following restrictions:

- Only GRF registers can be sources, and only GRF registers can be the destination.
- Subregister numbers have DWord granularity.



- AccessMode is Align16, uses Align16-style swizzling, with extra replication control. There is no other regioning support.

The next two subsections describe the instruction formats for various processor generations using tables. The following diagrams provide another view of the same information. The first two diagrams are for native instructions with one or two source operands.



GEN Instruction Format – 1-src and 2-src

DVI #	Instr Bits Alloc	High Bit	Low Bit	Instr Bits Used	AddrMode = Direct		AddrMode = Indirect		SEHD		MATH	Branch (Zollsets)	Branch (Zollset)	Imm Src	DVI		
					AccessMode = Align16	AccessMode = Align1	AccessMode = Align16	AccessMode = Align1	MsgDesc Imm	MsgDesc Reg							
3	1	127	127	1	EOT												
	2	126	125	2													
	4	124	121	4													
	4	120	117	4	Src1.VertStride												
	1	116	116	1													
	2	115	114	2	Src1.Width		Src1.Width										
	2	113	112	2	Src1.ChanSel[7:4]	Src1.HorzStride	Src1.ChanSel[7:4]	Src1.HorzStride					UPP[15:0]				
	1	111	111	1	Src1.AddrMode												
	2	110	109	2	Src1.Scroll												
	3	108	106	3	Src1.AddrSubRegNum												
	5	105	101	5	Src1.RegNum [7:0]												
	1	100	100	1	Src1.SubRegNum [4]	Src1.AddrImm [9:4]											
	4	99	96	4	Src1.ChanSel[3:0]	Src1.SubRegNum [4:0]	Src1.ChanSel[3:0]	Src1.AddrImm [9:0]	Imm[28:0]	Reg[32]	Same	JIP[15:0]	JIP[15:0]	Imm[31:0]			
2	5	95	91	5													
	1	90	90	1	FlagRegNum												
	1	89	89	1	FlagSubRegNum												
	4	88	85	4	Scroll.VertStride												
	1	84	84	1													
	2	83	82	2	Scroll.Width		Scroll.Width										
	2	81	80	2	Scroll.ChanSel[7:4]	Scroll.HorzStride	Scroll.ChanSel[7:4]	Scroll.HorzStride									
	1	79	79	1	Scroll.AddrMode												
	2	78	77	2	Scroll.Scroll												
	3	76	74	3	Scroll.AddrSubRegNum												
	5	73	69	5	Scroll.RegNum [7:0]												
	1	68	68	1	Scroll.SubRegNum [4]	Scroll.AddrImm [9:4]											
	4	67	64	4	Scroll.ChanSel[3:0]	Scroll.SubRegNum [4:0]	Scroll.ChanSel[3:0]	Scroll.AddrImm [9:0]	Same	Same	Same	Same	Same	Same	Imm[63:0]		
1	1	63	63	1	Dst.AddrMode												
	2	62	61	2	Dst.HorzStride		Dst.HorzStride										
	3	60	58	3	Dst.AddrSubRegNum												
	5	57	53	5	Dst.RegNum [7:0]												
	1	52	52	1	Dst.SubRegNum [4]	Dst.AddrImm [9:4]											
	4	51	48	4	Dst.ChanSel[3:0]	Dst.SubRegNum [4:0]	Dst.ChanSel[3:0]	Dst.AddrImm [9:0]	Same	Same	Same	Same	Same	Same	Same	Same	
	1	47	47	1	NbcCtrl												
	3	46	44	3	Src1.SrcType												
	2	43	42	2	Src1.RegFile												
	3	41	39	3	Scroll.SrcType												
	2	38	37	2	Scroll.RegFile												
	3	36	34	3	Dst.DstType												
	2	33	32	2	Dst.RegFile												
0	1	31	31	1	Saturate												
	1	30	30	1	DebugCtrl												
	1	29	29	1	CmpCtrl												
	1	28	28	1	AccWrCtrl												
	4	27	24	4	CondModifier												
	3	23	21	3	ExecSize												
	1	20	20	1	PredInv												
	4	19	16	4	PredCtrl												
	2	15	14	2	ThreadCtrl												
	2	13	12	2	CtrlCtrl												
	2	11	10	2	DepCtrl												
	1	9	9	1	WE Ctrl												
	1	8	8	1	AccessMode												
1	7	7	0	(reserved for Opcode)													
7	6	0	7	Opcode													



The next two diagrams are for instructions with three source operands.

GEN Instruction Format – 3-src

DW #	Instr Bits	High Bit	Low Bit	Instr Bits	Description	
2,3	2	127	126	0	reserved	
	8	125	118	8	Src2 Regnum	
	3	117	115	3	Src2 Subregnum	
	8	114	107	8	Src2 Swizzle	
	1	106	106	1	Src2 RepCtrl	
	1	105	105	0	reserved	
	8	104	97	8	Src1 Regnum	
	3	96	94	3	Src1 Subregnum	
	8	93	86	8	Src1 Swizzle	
	1	85	85	1	Src1 RepCtrl	
	1	84	84	0	reserved	
	8	83	76	8	Src0 Regnum	
	3	75	73	3	Src0 Subregnum	
	8	72	65	8	Src0 Swizzle	
	1	64	64	1	Src0 RepCtrl	
	1	8	63	56	8	Dst Regnum
		3	55	53	3	Dst Subregnum
		4	52	49	4	Dst chan enable
		1	48	48	0	reserved
		1	47	47	1	NibCtrl
1		46	46	0	reserved	
2		45	44	2	Dst Type	
2		43	42	2	Src Type	
2		41	40	2	Src2 Modifier	
2		39	38	2	Src1 Modifier	
2		37	36	2	Src0 Modifier	
1		35	35	0	reserved	
1		34	34	1	FlagRegNum	
1	33	33	1	Flag Sub Reg Num		
1	32	32	1	reserved		
0	1	31	31	1	Saturate	
	1	30	30	1	DebugCtrl	
	1	29	29	1	OpptCtrl	
	1	28	28	1	AccWrCtrl	
	4	27	24	4	CondModifier	
	3	23	21	3	Exec Size	
	1	20	20	1	PredInv	
	4	19	16	4	PredCtrl	
	2	15	14	2	ThreadCtrl	
	2	13	12	2	QtrCtrl	
	2	11	10	2	DepCtrl	
	1	9	9	1	WE Ctrl	
	1	8	8	1	AccessMode	
	1	7	7	0	(reserved for Opcode)	
0	7	6	0	7	Opcode	

EU Instruction Formats

This section describes the Execution Unit instruction formats.

This section covers the layout of instruction fields, not changes in allowed field encodings from generation to generation.



DWord 0, bits 31:0 of the 128-bit instruction, has the same format regardless of the number of source operands.

The following three tables cover the most common instruction format, for instructions with 1 or 2 source operands; then the format for the few instructions with 3 source operands; and finally format variations used by a few exceptional instructions.

Execution Unit Instruction Format for 1 or 2 Source Operands

Bits	Description	AddrMode and AccessMode Variations			
		AddrMode = Direct		AddrMode = Indirect	
		Align16	Align1	Align16	Align1
Any Imm32 32-bit immediate operand uses bits 127:96, replacing the following fields.					
127:121	Reserved				
120:117	Src1.VertStride				
116	Varies based on AccessMode				
115:114		Src1.ChanSel[7:4]		Src1.ChanSel[7:4]	
113:112				Src1.HorzStride	
111	Src1.AddrMode				
110:109	Src1.SrcMod				
108:106	Varies based on AddrMode and AccessMode	Src1.RegNum		Src1.AddrSubRegNum	
105:101				Src1.AddrImm[9:4]	Src1.AddrImm[9:0]
100					
99:96		Src1.ChanSel[3:0]	Src1.ChanSel[3:0]		
95:91	Reserved				
90	FlagRegNum				
89	FlagSubRegNum				
88:85	Src0.VertStride				
84	Varies based on AccessMode	Reserved	Src0.Width	Reserved	Src0.Width
83:82		Src0.ChanSel[7:4]		Src0.ChanSel[7:4]	
81:80				Src0.HorzStride	
79	Src0.AddrMode				
78:77	Src0.SrcMod				
76:74	Varies based on AddrMode and AccessMode	Src0.RegNum		Src0.AddrSubRegNum	
73:69				Src0.AddrImm[9:4]	Src0.AddrImm[9:0]
68					
67:64		Src0.ChanSel[3:0]	Src0.ChanSel[3:0]		
63	Dst.AddrMode				
62:61	Varies based on AccessMode				



Bits	Description	AddrMode and AccessMode Variations			
		AddrMode = Direct		AddrMode = Indirect	
		Align16	Align1	Align16	Align1
60:58	Varies based on AddrMode and AccessMode	Dst.RegNum		Dst.AddrSubRegNum	
57:53				Dst.AddrImm[9:4]	Dst.AddrImm[9:0]
52					
51:48		Dst.ChanEn[3:0]	Dst.ChanEn[3:0]		
47	HSW: NibCtrl				
46:44	Src1.SrcType				
43:42	Src1.RegFile				
41:39	Src0.SrcType				
38:37	Src0.RegFile				
36:34	Dst.DstType				
33:32	Dst.RegFile				
31	Saturate				
29	CmptCtrl				
28	AccWrCtrl				
27:24	CondModifier				
23:21	ExecSize				
20	PredInv				
19:16	PredCtrl				
15:14	ThreadCtrl				
13:12	QtrCtrl				
11:10	DepCtrl				
9	MaskCtrl				
8	AccessMode				
7	Reserved (for future Opcode expansion)				
6:0	Opcode				

The 3-source operand instructions are:

bfe - Bit Field Extract

bfi2 - Bit Field Insert 2

lrp - Linear Interpolation

mad - Multiply Add



In the 3-source instruction format, the upper QWord contains three groups of 21 bits for the three source operands, where each group contains four fields in 20 bits and otherwise adjacent groups are separated by single reserved bits.

Execution Unit Instruction Format for 3 Source Operands

Bits	Description
127:126	Reserved
125:118	Src2.RegNum
117:115	Src2.SubRegNum
114:107	Src2.ChanSel
106	Src2.RepCtrl
105	Reserved
104:97	Src1.RegNum
96	Src1.SubRegNum[2]
95:94	Src1.SubRegNum[1:0]
93:86	Src1.ChanSel
85	Src1.RepCtrl
84	Reserved
83:76	Src0.RegNum
75:73	Src0.SubRegNum
72:65	Src0.ChanSel
64	Src0.RepCtrl
63:56	Dst.RegNum
55:53	Dst.SubRegNum
52:49	Dst.ChanEnable
48	Reserved
47	NibCtrl
46	Reserved
45:44	DstType
43:42	SrcType
41:40	Src2.Modifier
39:38	Src1.Modifier
37:36	Src0.Modifier
35	Reserved
34	FlagRegNum



Bits	Description
33	FlagSubRegNum
32	HSW: Reserved
31	Saturate
29	CmptCtrl
28	AccWrCtrl
27:24	CondModifier
23:21	ExecSize
20	PredInv
19:16	PredCtrl
15:14	ThreadCtrl
13:12	QtrCtrl
11:10	DepCtrl
9	MaskCtrl
8	AccessMode
7	Reserved (for future Opcode expansion)
6:0	Opcode

Specific instructions have different instruction formats as described below. These instructions include send / sendc, math, and branch instructions.

Execution Unit Instruction Format for Specific Instructions

Bits	Regular 1 or 2 Source Operands Description	Empty white areas mean Same, use the regular description			
		send / sendc	math	Branch Instructions	
127	Reserved	EOT		UIP[15:0] (2-offset branches)	
126:125		Imm[28:0] / Reg32			Src1.VertStride
124:121					Varies based on AccessMode
120:117					
116:112					Src1.AddrMode
111		Src1.SrcMod			
110:109				Varies based on AddrMode and AccessMode	
108:96					
95:91	Reserved				
90	FlagRegNum				



Bits	Regular 1 or 2 Source Operands Description	Empty white areas mean Same, use the regular description		
		send / sendc	math	Branch Instructions
89	FlagSubRegNum			
88:85	Src0.VertStride			
84:80	Varies based on AccessMode			
79	Src0.AddrMode			
78:77	Src0.SrcMod			
76:64	Varies based on AddrMode and AccessMode			
63	Dst.AddrMode			Any branch instruction: Same as regular
62:61	Varies based on AccessMode			
60:48	Varies based on AddrMode and AccessMode			
47	HSW: NibCtrl			
46:44	Src1.SrcType			
43:42	Src1.RegFile			
41:39	Src0.SrcType			
38:37	Src0.RegFile			
36:34	Dst.DstType			
33:32	Dst.RegFile			
31	Saturate			
29	CmptCtrl			
28	AccWrCtrl			
27:24	CondModifier	SFID[3:0]	FC[3:0]	Any branch instruction: MBZ
23:21	ExecSize			
20	PredInv			
19:16	PredCtrl			
15:14	ThreadCtrl		Same as regular	
13:12	QtrCtrl			
11:10	DepCtrl			
9	MaskCtrl			
8	AccessMode			
7	Reserved (for future Opcode expansion)			



Bits	Regular 1 or 2 Source Operands Description	Empty white areas mean Same, use the regular description		
		send / sendc	math	Branch Instructions
6:0	Opcode			

Common Instruction Fields

As shown in the table below, the meanings (encoding) of certain bit fields in the 128-bit native instruction format varies depending on the values of other bit fields.

Definitions of Common Instruction Fields (below) provides the definition of common fields in the native instruction format. The *Width* column specifies the width of the field in bits. These common fields are referenced in describing the fields of different doublewords of the instruction. The definition for fields that have unique representations can be found in the sections for the corresponding instruction DWords.

Definitions of Common Instruction Fields

Field	Description	Width
CondModifier	<p>Conditional Modifier. This field sets the flag register based on the internal conditional signals output from the execution pipe such as sign, zero, overflow and NaNs, etc. If this field is set to 0000, no flag registers are updated. Flag registers are not updated for instructions with embedded compares.</p> <p>This field applies to all instructions except <i>send</i>, <i>sendc</i>, and <i>math</i>.</p> <p>0000 = Do not modify the flag register (normal)</p> <p>0001 = Zero or Equal (.z or .e)</p> <p>0010 = Not Zero or Not Equal (.nz or .ne)</p> <p>0011 = Greater-than (.g)</p> <p>0100 = Greater-than-or-equal (.ge)</p> <p>0101 = Less-than (.l)</p> <p>0110 = Less-than-or-equal (.le)</p> <p>0111 = Reserved</p> <p>1000 = Overflow (signed overflow) (.o)</p> <p>1001 = Unordered with Computed NaN (.u)</p> <p>1010 -1111 = Reserved</p>	4
AddrMode	<p>Addressing Mode. This field determines the addressing method of the operand. Normally the destination operand and each source operand each have a distinct addressing mode field.</p> <p>When it is cleared, the register address of the operand is directly provided by bits in the instruction word. It is called a direct register addressing mode. When it is set, the register</p>	1



Field	Description	Width
	<p>address of the operand is computed based on the address register value and an address immediate field in the instruction word. This is referred to as a register-indirect register addressing mode.</p> <p>This field applies to the destination operand and the first source operand, src0. Support for src1 is device dependent. See Table XX (Indirect source addressing support available in device hardware) in ISA Execution Environment for details.</p> <p>0 = <i>Direct</i>. Direct register addressing</p> <p>1 = <i>Register-Indirect</i> (or in short <i>Indirect</i>). Register-indirect register addressing</p>	
RegNum	<p>Register Number. This field provides the register number for the operand. For GRF register operand, it provides the portion of register address aligning to 256-bit. For an ARF register operand, this field is encoded such that MSBs identify the architecture register type and LSBs provide its register number.</p> <p>This field together with the corresponding <i>SubRegNum</i> field provides the byte aligned address for the origin of the register region. Specifically, this field provides bits [12:5] of the byte address, while <i>SubRegNum</i> field provides bits [4:0].</p> <p>This field applies to the destination operand and the source operands. It is ignored (or not present in the instruction word) for an immediate source operand.</p> <p>This field is present if the operand is in direct addressing mode; it is not present if the operand is register-indirect addressed.</p> <p>Format = U8, if <i>RegFile</i> = GRF.</p> <p>0x00 to 0x7F = Register number in the range of [0, 127]</p> <p>0x80 to 0xFF = Reserved</p> <p>Format = U8</p> <p>0x00 to 0x0F = Register number in the range of [0, 15]</p> <p>0x10 to 0xFF = Reserved</p> <p>Format = 8-bit encoding, if <i>RegFile</i> = ARF.</p> <p>This field is used to encode the architecture register as well as providing the register number. See GEN Execution Environment chapter for details.</p>	8
SubRegNum	<p>Sub-Register Number. This field provides the sub-register number for the operand. For a GRF register operand, it provides the byte address within a 256-bit register. For an ARF register operand, this field also provides the sub-register number according to the encoding defined for the given architecture register.</p> <p>This field together with the corresponding <i>RegNum</i> field provides the byte aligned address for the origin of the register region. Specifically, this field provides bits [4:0] of the byte address, while the <i>RegNum</i> field provides bits [12:5].</p> <p>This field applies to the destination operand and the source operands. It is ignored (or</p>	5



Field	Description	Width
	<p>not present in the instruction word) for an immediate source operand.</p> <p>This field is present if the operand is in direct addressing mode; it is not present if the operand is register-indirect addressed.</p> <p>Note: The recommended instruction syntax uses sub-register numbers within the GRF in units of actual data element size, corresponding to the data type used. For example for the F (Float) type, the assembler syntax uses sub-register numbers 0 to 7, corresponding to sub-register byte addresses of 0 to 28 in steps of 4, the element size.</p> <p>Format = U5, if <i>RegFile</i> = GRF</p> <p>0x00 to 0x1F = Sub-Register number in the range of [0, 31]</p> <p>Format = 5-bit encoding, if <i>RegFile</i> = ARF.</p> <p>This field is used to encode the architecture register as well as providing the register number. See GEN Execution Environment chapter for details.</p>	
AddrSubRegNum	<p>Address Sub-Register Number. This field provides the sub-register number for the address register. The address register contains 8 sub-registers. The size of each sub-register is one word. The address register contains the register address of the operand, when the operand is in register-indirect addressing mode.</p> <p>This field applies to the destination operand and the source operands. It is ignored (or not present in the instruction word) for an immediate source operand.</p> <p>This field is present if the operand is in register-indirect addressing mode; it is not present if the operand is directly addressed.</p> <p>An address sub-register used for indirect addressing is often called an <i>index register</i>.</p> <p>Format = U3</p> <p>0x0 to 0x7 = Address Sub-Register number in the range [0, 7]</p>	3
AddrImm	<p>Address Immediate. This field provides the immediate value in units of bytes added to the address register to compute the register address (byte-aligned region origin) for the operand. It is a signed integer.</p> <p>This field is present if the operand is in register-indirect addressing mode; it is not present if the operand is directly addressed.</p> <p><i>Note: that the address immediate field may not be able to cover the whole GRF register range for a thread, as the maximum GRF register space for a thread is 4KB.</i></p> <p>Format = S9</p> <p>Valid range: [-512, 511]</p>	10
SrcMod	<p>Source Modifier. This field specifies the numeric modification of a source operand. The value of each data element of a source operand can optionally have its absolute value taken and/or its sign inverted prior to delivery to the execution pipe. The absolute value</p>	2



Field	Description	Width
	<p>is prior to negate such that a guaranteed negative value can be produced.</p> <p>This field only applies to source operand. It does not apply to destination.</p> <p>This field is not present for an immediate source operand.</p> <p>00 = No modification (normal)</p> <p>01 = <i>(abs)</i>. Absolute</p> <p>10 = -. Negate</p> <p>11 = <i>-(abs)</i>. Negate of the absolute (forced negative value)</p>	
VertStride	<p>Vertical Stride. The field provides the vertical stride of the register region in unit of data elements for an operand.</p> <p>Encoding of this field provides values of 0 or powers of 2, ranging from 1 to 32 elements. Larger values are not supported due to the restriction that a source operand must reside within two adjacent 256-bit registers (64 bytes total).</p> <p>Special encoding 1111b (0xF) is only valid when the operand is in register-indirect addressing mode (<i>AddrMode</i> = 1). If this field is set to 0xF, one or more sub-registers of the address registers may be used to compute the addresses. Each address sub-register provides the origin for a row of data element. The number of address sub-registers used is determined by the division of <i>ExecSize</i> of the instruction by the <i>Width</i> fields of the operand.</p> <p>This field only applies to source operand. It does not apply to destination.</p> <p>This field is not present for an immediate source operand.</p> <p>For Align16 access mode, only encodings of 0000, 0010 and 0011 are allowed. Other codes are reserved.</p> <p><i>Note 1: Vertical Stride larger than 32 is not allowed due to the restriction that a source operand must reside within two adjacent 256-bit registers (64 bytes total).</i></p> <p><i>Note 2: In Align16 access mode, as encoding 0xF is reserved, only single-index indirect addressing is supported.</i></p> <p><i>Note 3: If indirect address is supported for src1, encoding 0xF is reserved for src1 - only single-index indirect addressing is supported.</i></p> <p><i>Note 4: Encoding 0010 applies for QWord-size operands.</i></p> <p>0000 = 0 Elements</p> <p>0001 = 1 Element</p> <p>0010 = 2 Elements</p> <p>0011 = 4 Elements</p> <p>0100 = 8 Elements</p> <p>0101 = 16 Elements (applies to byte or word operand only)</p>	4



Field	Description	Width
	0110 = 32 Elements (applies to byte operand only) 0111-1110 = Reserved 1111 = VxH or Vx1 mode (only valid for register-indirect addressing in Align1 mode)	
Width	<p>Width. This field specifies the number of elements in the horizontal dimension of the region for a source operand. This field cannot exceed the <i>ExecSize</i> field of the instruction.</p> <p>This field only applies to source operand. It does not apply to destination.</p> <p>This field is not present for an immediate source operand.</p> <p>000 = 1 Elements 001 = 2 Elements 010 = 4 Elements 011 = 8 Elements 100 = 16 Elements 101-111 = Reserved</p>	3
HorzStride	<p>Horizontal Stride. This field provides the distance in unit of data elements between two adjacent data elements within a row (horizontal) in the register region for the operand.</p> <p>This field applies to both destination and source operands.</p> <p>This field is not present for an immediate source operand.</p> <p>00 = 0 Elements 01 = 1 Element 10 = 2 Elements 11 = 4 Elements</p>	2
Imm32	<p>32-bit Immediate. The 32-bit immediate data field for the operand. It may contain any legal bit pattern for its associated type. Only one 32-bit immediate value may be present in an instruction, therefore binary operations only support src1 as an immediate value.</p> <p>The low order bits are directly used when fewer than 32-bits are needed to describe the desired type; the 32-bits are not coerced into the designated type.</p> <p>For UW and W data types, programmer is required to replicate the lower word to the upper word of this field.</p> <p>This field only applies to the last source operand.</p> <p>Signed and unsigned byte integer data types are not supported for an immediate operand.</p>	32



Field	Description	Width
	See the Numeric Data Types section for information about data types and their ranges.	
ChanEn	<p>Channel Enable. Four channel enables are defined for controlling which channels will be written into the destination region. These channel mask bits are applied in a modulo-four manner to all <i>ExecSize</i> channels. There is 1-bit Channel Enable for each channel within the group of 4. If the bit is cleared, the write for the corresponding channel is disabled. If the bit is set, the write is enabled. Mnemonic for the bit being set for the group of 4 is <i>x</i>, <i>y</i>, <i>z</i>, and <i>w</i>, respectively, where <i>x</i> corresponds to Channel 0 in the group and <i>w</i> corresponds to channel 3 in the group.</p> <p>This field only applies to destination operand.</p> <p>This field is only present in Align16 mode.</p> <p>0 = Write Disabled 1 = Write Enabled (normal)</p>	4
ChanSel	<p>Channel Select. This field controls the channel swizzle for a source operand. The normally sequential channel assignment can be altered by explicitly identifying neighboring data elements for each channel. Out of the 8-bit field, 2 bits are assigned for each channel within the group of 4. ChanSel[1:0], [3:2], [5:4] and [7,6] are for channel 0 (<i>x</i>), 1 (<i>y</i>), 2 (<i>z</i>), and 3 (<i>w</i>) in the group, respectively.</p> <p>For example with an execution size of 8, <i>r0.0<4>.zywz:f</i> would assign the channels as follows: Chan₀ = Data₂, Chan₁ = Data₁, Chan₂ = Data₃, Chan₃ = Data₂; Chan₄ = Data₆, Chan₅ = Data₅, Chan₆ = Data₇, Chan₇ = Data₆.</p> <p>This field only applies to source operand.</p> <p>This field is only present in Align16 mode. It is not present for an immediate source operand.</p> <p>The 2-bit Channel Selection field for each channel within the group of 4 is defined as the following.</p> <p>00 = <i>x</i>. Channel 0 is selected for the corresponding execution channel 01 = <i>y</i>. Channel 1 is selected for the corresponding execution channel 10 = <i>z</i>. Channel 2 is selected for the corresponding execution channel 11 = <i>w</i>. Channel 3 is selected for the corresponding execution channel</p>	8
RepCtrl	<p>Replicate Control. This field controls the replication of the starting channel to all channels in the execution size.</p> <p>This field applies to all three source operands.</p> <p>0 = No replication 1 = Replicate across all channels</p>	1



Field	Description	Width
MsgDscpt31	<p>Message Description. This field, containing 31-bit immediate values, provides the description of the message to be sent.</p> <p>This field only applies to the <i>send</i> instruction. It is not present for other instructions.</p> <p>The meaning of the field depends on the type of message as well as the message shared function target.</p> <p>Format: U31</p>	31
EOT	<p>End of Thread. This field controls the termination of the thread. For a <i>send</i> instruction, if this field is set, EU will terminate the thread and also set the EOT bit in the message sideband.</p> <p>This field only applies to the <i>send</i> instruction. It is not present for other instructions.</p> <p>0 = The thread is not terminated</p> <p>1 = EOT</p>	1

Instruction Operation Doubleword (DW0)

Most fields in Instruction Operation Doubleword (DW0) apply to all instructions. Bit field [27:24] is one exception. It is *CondModifier* for most instructions but is *SFID[3:0]* field for the *send* instruction.

The descriptions in the table below are shared between the 1-src/2-src instructions and 3-src instructions.

Definitions of Fields in Operation Doubleword (DW0)

Bits	Description		
31	<p>Saturate. This field controls the destination saturation.</p> <p>When it is set, output data to the destination register are saturated. The saturation operation depends on the destination data type. Saturation is the operation that converts any data that is outside the <i>saturation target range</i> for the data type to the closest represented value with the target range. If destination type is float, saturation target range is [0, 1]. For example, any positive number greater than 1 (including +INF) is saturated to 1 and any negative number (including -INF) is saturated to 0. A NaN is saturated to 0. For integer data types, the maximum range for the given numeric data type is the saturation target range.</p> <p>When it is not set, output data to the destination register are not saturated. For example, a wrapped result (modular) is output to the destination for an overflowed integer data.</p> <p>More details can be found in the Data Types chapter.</p> <p>0 = No destination modification (normal)</p> <p>1 = <i>sat</i>. Saturate the output</p> <table border="1" data-bbox="219 1843 911 1892"> <tr> <td>Destination Type</td> <td>Saturation Target Range (inclusive)</td> </tr> </table>	Destination Type	Saturation Target Range (inclusive)
Destination Type	Saturation Target Range (inclusive)		



Bits	Description					
	Float (F)	[0.0, 1.0]				
	Byte (UB)	[0, 255]				
	Signed Byte (B)	[-128, 127]				
	Word (UW)	[0, 65535]				
	Signed Word (W)	[-32768, 32767]				
	Double Word (UD)	[0, 2 ³² -1]				
	Signed Double (D)	[-2 ³¹ , 2 ³¹ -1]				
30	Reserved					
29	Reserved: MBZ					
28	<p>AccWrCtrl. This field allows per instruction accumulator write control.</p> <p>0 = don't write result into accumulator</p> <p>1 = <i>AccWrCtrl.</i> write result into accumulator, and destination</p>					
27:24	<p>CondModifier or CurrDst.RegNum[3:0]</p> <p>Definition of this bit field depends on whether the instruction is a <i>send/math</i> or not.</p> <table border="1" style="width: 100%; border-collapse: collapse;"> <thead> <tr> <th style="text-align: center; color: #0070C0;">Opcode != send</th> <th style="text-align: center; color: #0070C0;">Opcode = send</th> </tr> </thead> <tbody> <tr> <td style="vertical-align: top;"> <p>CondModifier:</p> <p>This field sets the flag register based on the internal conditional signals output from the execution pipe.</p> </td> <td style="vertical-align: top;"> <p>CurrDst.RegNum[3:0]</p> <p>(See Instruction Reference chapter for <i>CurrDst.</i>)</p> </td> </tr> </tbody> </table>		Opcode != send	Opcode = send	<p>CondModifier:</p> <p>This field sets the flag register based on the internal conditional signals output from the execution pipe.</p>	<p>CurrDst.RegNum[3:0]</p> <p>(See Instruction Reference chapter for <i>CurrDst.</i>)</p>
Opcode != send	Opcode = send					
<p>CondModifier:</p> <p>This field sets the flag register based on the internal conditional signals output from the execution pipe.</p>	<p>CurrDst.RegNum[3:0]</p> <p>(See Instruction Reference chapter for <i>CurrDst.</i>)</p>					
23:21	<p>ExecSize - Execution Size. This field determines the number of channels operating in parallel for this instruction. The size cannot exceed the maximum number of channels allowed for the given data type.</p> <p>000b = 1 channel (scalar operation)</p> <p>001b = 2 channels</p> <p>010b = 4 channels</p> <p>011b = 8 channels</p> <p>100b = 16 channels</p> <p>101 = 32 channels</p> <p>110-111 = Reserved</p>					
20	<p>PredInv - Predicate Inverse. This field, together with <i>PredCtrl</i>, enables and controls the generation of the predication mask for the instruction. When it is set, the predication uses the inverse of the predication bits</p>					



Bits	Description
	<p>generated according to setting of Predicate Control. In other words, effect of <i>PredInv</i> happens after <i>PredCtrl</i>. This field is ignored by hardware if Predicate Control is set to 0000 - there is no predication.</p> <p>0 = +. Positive polarity of predication.</p> <p>1 = -. Negative polarity of predication.</p>
19:16	<p>PredCtrl - Predicate Control. This field, together with <i>PredInv</i>, enables and controls the generation of the predication mask for the instruction. It allows per-channel conditional execution of the instruction based on the content of the selected flag register. Encoding depends on the access mode.</p> <p>In Align16 access mode, there are eight encodings (including no predication). All encodings are based on group-of-4 predicate bits, including channel sequential, replication swizzles and horizontal any/all operations. The same configuration is repeated for each group-of-4 execution channels.</p> <p>See the Predication section for more informatio about predication.</p> <p>In Align1 access mode, there are twelve encodings (including no predication). The encodings applies to all execution channels with explicit channel grouping from single channel up to group of 16 channels.</p> <p>Predicate Control in Align16 access mode</p> <p>0000 = No predication (normal)</p> <p>0001 = Predication with sequential flag channel mapping</p> <p>0010 = Predication with replication swizzle .x</p> <p>0011 = Predication with replication swizzle .y</p> <p>0100 = Predication with replication swizzle .z</p> <p>0101 = Predication with replication swizzle .w</p> <p>0110 = Predication with .any4h</p> <p>0111 = Predication with .all4h</p> <p>1000 -1111 = Reserved</p> <p>Predicate Control in Align1 access mode</p> <p>0000 = No predication (normal)</p> <p>0001 = Predication with sequential flag channel mapping</p> <p>0010 = Predication with .anyv (any from f0.0-f0.1 on the same channel)</p> <p>0011 = Predication with .allv (all of f0.0-f0.1 on the same channel)</p> <p>0100 = Predication with .any2h (any in group of 2 channels)</p> <p>0101 = Predication with .all2h (all in group of 2 channels)</p> <p>0110 = Predication with .any4h (any in group of 4 channels)</p> <p>0111 = Predication with .all4h (all in group of 4 channels)</p> <p>1000 = Predication with .any8h (any in group of 8 channels)</p>



Bits	Description																									
	1001 = Predication with .all8h (all in group of 8 channels) 1010 = Predication with .any16h (any in group of 16 channels) 1011 = Predication with .all16h (all in group of 16 channels) 1100 = Predication with .any32h (any in group of 32 channels) 1101 = Predication with .all32h (all in group of 32 channels) 1110 -1111 = Reserved																									
15:14	<p>ThreadCtrl - Thread Control. This field provides explicit control for thread switching.</p> <p>If this field is set to 00b, it is up to the GEN execution units to manage thread switching. This is the normal (and unnamed) mode. In this mode, for example, if the current instruction cannot proceed due to operand dependencies, the EU switches to the next available thread to fill the compute pipe. In another example, if the current instruction is ready to go, however, there is another thread with higher priority that also has an instruction ready, the EU switches to that thread.</p> <p>If this field is set to Switch, a forced thread switch occurs after the current instruction is executed and before the next instruction. In addition, a long delay (longer than the execution pipe latency) is introduced for the current thread. Particularly, the instruction queue of the current thread is flushed after the current instruction is dispatched for execution. Switch is designed primarily as a safety feature in case there are race conditions for certain instructions.</p> <p>If this field is set to Atomic, the next instruction gets highest priority in thread arbitration for the execution pipeline.</p> <p>00b = Normal thread control 10b = <i>Switch</i> 01b = <i>Atomic</i> 11b = Reserved</p>																									
13:12	<p>QtrCtrl - Quarter Control. This field provides explicit control for ARF selection.</p> <p>This field combines with ExecSize determines which channels are used for the ARF registers.</p> <p>Along with NibCtrl in DW1, 1/8 DMask/VMask and ARF can be selected.</p> <table border="1" data-bbox="220 1541 1141 1906"> <thead> <tr> <th data-bbox="220 1541 323 1583">QtrCtrl</th> <th data-bbox="323 1541 428 1583">NibCtrl</th> <th data-bbox="428 1541 550 1583">ExecSize</th> <th data-bbox="550 1541 1073 1583">Description</th> <th data-bbox="1073 1541 1141 1583">BNF</th> </tr> </thead> <tbody> <tr> <td data-bbox="220 1583 323 1667">00</td> <td data-bbox="323 1583 428 1667">x</td> <td data-bbox="428 1583 550 1667">8</td> <td data-bbox="550 1583 1073 1667">use first quarter for DMask/VMask use first half for everything else</td> <td data-bbox="1073 1583 1141 1667">1Q</td> </tr> <tr> <td data-bbox="220 1667 323 1751">01</td> <td data-bbox="323 1667 428 1751">x</td> <td data-bbox="428 1667 550 1751">8</td> <td data-bbox="550 1667 1073 1751">use second quarter for DMask/VMask use second half for everything else</td> <td data-bbox="1073 1667 1141 1751">2Q</td> </tr> <tr> <td data-bbox="220 1751 323 1835">10</td> <td data-bbox="323 1751 428 1835">x</td> <td data-bbox="428 1751 550 1835">8</td> <td data-bbox="550 1751 1073 1835">use third quarter for DMask/VMask use first half for everything else</td> <td data-bbox="1073 1751 1141 1835">3Q</td> </tr> <tr> <td data-bbox="220 1835 323 1906">11</td> <td data-bbox="323 1835 428 1906">x</td> <td data-bbox="428 1835 550 1906">8</td> <td data-bbox="550 1835 1073 1906">use forth quarter for DMask/VMask use second half for everything else</td> <td data-bbox="1073 1835 1141 1906">4Q</td> </tr> </tbody> </table>	QtrCtrl	NibCtrl	ExecSize	Description	BNF	00	x	8	use first quarter for DMask/VMask use first half for everything else	1Q	01	x	8	use second quarter for DMask/VMask use second half for everything else	2Q	10	x	8	use third quarter for DMask/VMask use first half for everything else	3Q	11	x	8	use forth quarter for DMask/VMask use second half for everything else	4Q
QtrCtrl	NibCtrl	ExecSize	Description	BNF																						
00	x	8	use first quarter for DMask/VMask use first half for everything else	1Q																						
01	x	8	use second quarter for DMask/VMask use second half for everything else	2Q																						
10	x	8	use third quarter for DMask/VMask use first half for everything else	3Q																						
11	x	8	use forth quarter for DMask/VMask use second half for everything else	4Q																						



Bits	Description				
	0x	x	16	use first half for DMask/VMask use all channels for everything else	1H
	1x	x	16	use second half for DMask/VMask use all channels for everything else	2H
	00	0	4	use first 1/8 for DMask/VMask and ARF	1N
	00	1	4	use second 1/8 for DMask/VMask and ARF	2N
	01	0	4	use third 1/8 for DMask/VMask and ARF	3N
	01	1	4	use fourth 1/8 for DMask/VMask and ARF	4N
	10	0	4	use fifth 1/8 for DMask/VMask and ARF	5N
	10	1	4	use sixth 1/8 for DMask/VMask and ARF	6N
	11	0	4	use seventh 1/8 for DMask/VMask and ARF	7N
	11	1	4	use eighth 1/8 for DMask/VMask and ARF	8N
<p>2H is only allowed for SIMD16 instruction in Single Program Flow mode (SPF=1).</p> <p>NibCtrl is only allowed for SIMD4 instructions with (DF) double precision source and/or destination.</p>					
11:10	<p>DepCtrl - Destination Dependency Control. This field selectively disables destination dependency check and clear for this instruction.</p> <p>When it is set to 00, normal destination dependency control is performed for the instruction - hardware checks for destination hazards to ensure data integrity. Specifically, destination register dependency check is conducted before the instruction is made ready for execution. After the instruction is executed, the destination register scoreboard will be cleared when the destination operands retire.</p> <p>When bit 10 is set (NoDDClr), the destination register scoreboard will NOT be cleared when the destination operands retire. When bit 11 is set (NoDDChk), hardware does not check for destination register dependency before the instruction is made ready for execution. NoDDClr and NoDDChk are not mutual exclusive.</p> <p>When this field is not all-zero, hardware does not protect against destination hazards for the instruction. This is typically used to assemble data in a fine grained fashion (e.g. matrix-vector compute with dot-product instructions), where the data integrity is guaranteed by software based on the intended usage of instruction sequences.</p> <p>00 = Destination dependency checked and cleared (normal) 01 = <i>NoDDClr</i>. Destination dependency checked but not cleared 10 = <i>NoDDChk</i>. Destination dependency not checked but cleared 11 = <i>NoDDClr, NoDDChk</i>. Destination dependency not checked and not cleared</p>				
9	<p>MaskCtrl - Mask Control (formerly Write Enable Control). This field determines if the per channel write enables are used to generate the final write enable. This field should be normally 0.</p> <p>0 = use normal write enables (normal)</p>				



Bits	Description
	1 = write all channels, except channels killed with predication control. ChanEn is ignored in this case. MaskCtrl = NoMask skips the check for PciP[n] == ExIP before enabling a channel, as described in the Evaluate Write Enable section.
8	AccessMode - Access Mode. This field determines the operand access for the instruction. It applies to all source and destination operands. When it is cleared (Align1), the instruction uses byte-aligned addressing for source and destination operands. Source swizzle control and destination mask control are not supported. When it is set (Align16), the instruction uses 16-byte-aligned addressing for all source and destination operands. Source swizzle control and destination mask control are supported in this mode. 0 = <i>Align1</i> 1 = <i>Align16</i>
7	Reserved: MBZ (for future opcode extension)
6:0	Opcode - Instruction Operation Code. This field contains the instruction operation code. Each opcode is given a unique mnemonic. For example, opcode 0x01 is for a move operation. Mnemonic for this opcode is <i>mov</i> . See section 5.3 for details of opcode encoding.

Instruction Destination Doubleword (DW1)

DW1 1-src and 2-src Instructions

Destination Doubleword (DW1) contains the register file and numeric type of all operands, as well as the register region parameters of the destination operand. See the [Region Parameters](#) section and the sections following it for more information about those parameters.

Instruction Destination Doubleword

Bits	Description
31:16	Destination Register Region. This word contains the parameters describing the register region of the destination operand. Subfield definition depends on the AccessMode. See the Region Parameters section and the sections following it for more information about these parameters. Programming Notes: Although <i>Dst.HorzStride</i> is a don't care for Align16, HW needs this to be programmed as <i>01</i> .
15	Reserved: MBZ



Bits	Description
14:12	<p>Src1.SrcType – Source 1 Data Type. This field specifies the numeric data type of the source operand src1. The bits of a source operand are interpreted as the identified numeric data type, rather than coerced into a type implied by the operator. Depending on <i>RegFile</i> field of the source operand, there are two different encoding for this field. If a source is a register operand, this field follows the Source Register Type Encoding. If a source is an immediate operand, this field follows the Source Immediate Type Encoding.</p> <p>Source Register Type Encoding is identical to that for Destination Type.</p> <p>Source Immediate Type Encoding differs in two areas. First, it does not support byte and unsigned numeric data types. Second, it has three packed vector types, the V, UV, and VF types.</p> <p><i>Implementation Note 1: Both source operands, src0 and src1, support immediate types, but only one immediate is allowed for a given instruction and it must be the last operand.</i></p> <p><i>Implementation Note 2: Halfbyte integer vector (v) type can only be used in instructions in packed-word execution mode. Therefore, in a two-source instruction where src1 is of type :v, src0 must be of type :b, :ub, :w, or :uw.</i></p> <p>Source Register Type Encoding</p> <ul style="list-style-type: none"> 000 = UD. Unsigned Doubleword integer 001 = D. Signed Doubleword integer 010 = UW. Unsigned Word integer 011 = W. Signed Word integer 100 = UB. Unsigned Byte integer 101 = B. Signed Byte integer 110 = DF. Double precision Float (64-bit) [DevIVB+] 111 = F. Single precision Float (32-bit) <p>Source Immediate Type Encoding:</p> <ul style="list-style-type: none"> 000 = UD 001 = D 010 = UW 011 = W 100 = UV. 32-bit halfbyte Unsigned Integer Vector 101 = VF. 32-bit restricted Vector Float <ul style="list-style-type: none"> 110 = V. 32-bit halfbyte integer Vector 111 = F
11:10	<p>Src1.RegFile – Source 1 Register File. This field identifies the register file of source operand src1.</p>



Bits	Description
	00 = <i>ARF</i> . Architecture Register File (a# , acc# , f# , n# , null , ip , etc.) 01 = <i>GRF</i> . General Register File (r#) 10 = Reserved . Do not use this encoding. 11 = <i>IMM</i> . Immediate
9:7	Src0.SrcType – Source 0 Data Type . This field is the <i>SrcType</i> for src0 operand. It has the same definitions as <i>Src1.SrcType</i> .
6:5	Src0.RegFile – Source 0 Register File . This field is the <i>RegFile</i> for src0 operand. It has the same definitions as <i>Src1.RegFile</i> .
4:2	Dst.DstType – Destination Data Type . This field specifies the numeric data type of the destination operand <i>dst</i> . The bits of the destination operand are interpreted as the identified numeric data type, rather than coerced into a type implied by the operator. For a <i>send</i> instruction, this field applies to the CurrDst – the current destination operand. Encoding: 000 = <i>UD</i> . U nsigned D oubleword integer 001 = <i>D</i> . Signed D oubleword integer 010 = <i>UW</i> . U nsigned W ord integer 011 = <i>W</i> . Signed W ord integer 100 = <i>UB</i> . U nsigned B yte integer 101 = <i>B</i> . Signed B yte integer 110 = [DF] D ouble Precision F loat (64-bit) [DevIVB+] 111 = <i>F</i> . Single precision F loat (32-bit)
1:0	Dst.RegFile – Destination Register File . This field identifies the register file of the destination operand <i>dst</i> . Note that it is obvious that immediate cannot be a destination operand. For a <i>send</i> instruction, this field applies to the PostDst – the post destination operand. Encoding: 00 = <i>ARF</i> . Architecture Register File (a# , acc# , f# , n# , null , ip , etc.) 01 = <i>GRF</i> . General Register File (r#) 10 = Reserved . Do not use this encoding. 11 = reserved

The following tables describe the Destination Register Region based on the access mode and addressing mode.



Destination Register Region in Direct + Align16 mode

Bits	Description
15	Dst.AddrMode – Destination Address Mode. This field is the <i>AddrMode</i> for the destination operand. For a <i>send</i> instruction, this field applies to PostDst – the post destination operand. Addressing mode for <i>CurrDst</i> (current destination operand) is fixed as Direct. (See Instruction Reference chapter for <i>CurrDst</i> and <i>PostDst</i> .)
14:13	Reserved: MBZ
12:5	Dst.RegNum – Destination Register Number. This field is the <i>RegNum</i> field for the destination operand. For a <i>send</i> instruction, this field applies to PostDst .
4	Dst.SubRegNum[4]. This is the 16-byte aligned sub-register address. For a <i>send</i> instruction, this field applies to CurrDst .
3:0	Dst.ChanEn – Destination Channel Enable. The channel enable field for the destination operand. For a <i>send</i> instruction, this field applies to the CurrDst .

Destination Register Region in Direct+Align1 mode

Bits	Description
15	Dst.AddrMode – Destination Address Mode. This field is the <i>AddrMode</i> for the destination operand. For a <i>send</i> instruction, it applies to PostDst . Addressing mode for <i>CurrDst</i> is fixed as Direct.
14:13	Dst.HorzStride – Destination Horizontal Stride. This field is the <i>HorzStride</i> for the destination operand. For a <i>send</i> instruction, this field applies to CurrDst . PostDst only uses the register number.
12:5	Dst.RegNum – Destination Register Number. This field is the <i>RegNum</i> field for the destination operand. For a <i>send</i> instruction, this field applies to PostDst .
4:0	Dst.SubRegNum – Destination Sub-Register Number. This field is the SubRegNum for the destination operand.) Note: The recommended instruction syntax uses GRF sub-register numbers in units of element size, which the assembler translates to the appropriate value for this field. For a <i>send</i> instruction, this field applies to CurrDst .

Destination Register Region in Indirect+Align16 mode

Bits	Description
------	-------------



Bits	Description
15	Dst.AddrMode – Destination Address Mode. This field is the <i>AddrMode</i> for the destination operand. For a <i>send</i> instruction, this field applies to PostDst . Addressing mode for <i>CurrDst</i> is fixed as Direct.
14:13	Reserved: MBZ
12:10	Dst.AddrSubRegNum – Destination Address Sub-Register Number. This field is the <i>AddrSubRegNum</i> for the destination operand. For a <i>send</i> instruction, this field applies to PostDst .
9:4	Dst.AddrImm[9:4] This is the half-register aligned <i>AddrImm</i> field for the destination operand. For a <i>send</i> instruction, this field applies to PostDst .
3:0	Dst.ChanEn – Destination Channel Enable. The channel enable field for the destination operand. For a <i>send</i> instruction, this field applies to the CurrDst .

Destination Register Region in Indirect+Align1 mode

Bits	Description
15	Dst.AddrMode – Destination Address Mode. This field is the <i>AddrMode</i> for the destination operand. For a <i>send</i> instruction, this field applies to PostDst . Addressing mode for <i>CurrDst</i> is fixed as Direct.
14:13	Dst.HorzStride – Destination Horizontal Stride This field is the <i>HorzStride</i> for the destination operand. For a <i>send</i> instruction, this field applies to CurrDst . PostDst only uses the register number.
12:10	Dst.AddrSubRegNum – Destination Address Sub-Register Number. This field is the <i>AddrSubRegNum</i> for the destination operand. For a <i>send</i> instruction, this field applies to PostDst .
9:0	Dst.AddrImm – Destination Address Immediate. This field is the byte-aligned <i>AddrImm</i> for the destination operand. For a <i>send</i> instruction, this field applies to PostDst .

DW1 3-src Instructions

This section describes the field in DW1 for the 3-src instruction format.



Instruction DW1

Bits	Description
31:24	Destination Register Number. This field contains the destination register number.
23:21	<p>Destination Subregister Number. This field contains the destination sub-register number.</p> <p>Note: The recommended instruction syntax uses GRF sub-register numbers in units of element size, which the assembler translates to the appropriate value for this field.</p>
20:17	<p>Destination Channel Enable. Four channel enables are defined for controlling which channels are written into the destination region. These channel mask bits are applied in a modulo-four manner to all <i>ExecSize</i> channels. There is 1-bit Channel Enable for each channel within the group of 4. If the bit is cleared, the write for the corresponding channel is disabled. If the bit is set, the write is enabled. Mnemonics for the bit being set for the group of 4 are <i>x</i>, <i>y</i>, <i>z</i>, and <i>w</i>, respectively, where <i>x</i> corresponds to Channel 0 in the group and <i>w</i> corresponds to channel 3 in the group.</p> <p>0: Write Disabled 1: Write Enabled (normal)</p>
16:15	<p>Dst Type. This field contains the data type for the destination.</p> <p>00b = Single Precision Float 01b = DWord 10b = Unsigned DWord 11b = Double Precision Float</p>
14:13	<p>Src Type. This field contains the data type for all three sources.</p> <p>00b = Single Precision Float 01b = DWord 10b = Unsigned DWord 11b = Double Precision Float</p>
12:10	Reserved: MBZ
9:8	<p>Source2 Modifier. This field contains the modifier for source2.</p> <p>Refer to Table 5-5 for the encoding.</p>
7:6	<p>Source1 Modifier. This field contains the modifier for source1.</p> <p>Refer to Table 5-5 for the encoding.</p>
5:4	<p>Source0 Modifier. This field contains the modifier for source0.</p> <p>Refer to Table 5-5 for the encoding.</p>



Bits	Description
3	Reserved: MBZ
2	[DevIVB+] Flag Register Number. This field contains the flag register number for instructions with a non-zero Conditional Modifier.
1	Flag Subregister Number. This field contains the flag sub-register number for instructions with a non-zero Conditional Modifier.
0	Reserved

Instruction Source 0 Doubleword 2 (DW2)

DW2 1-src and 2-src Instructions

Instruction Source 0 Doubleword 2 (DW2) contains the first source operand and also flag register number.

- *Instruction Source 0 Doubleword 2 (DW2)* shows the field definition for Direct Addressing with Align16.
- *Instruction Source 0 Doubleword 2 (DW2)* shows the field definition for Direct Addressing with Align1.
- *Instruction Source 0 Doubleword 2 (DW2)* shows the field definition for Indirect Addressing with Align16.
- *Instruction Source 0 Doubleword 2 (DW2)* shows the field definition for Indirect Addressing with Align1.

Instruction Source 0 Doubleword in Direct+Align16 mode

Bits	Description
31:26	Reserved: MBZ
25	FlagSubRegNum – Flag Sub-Register Number. This field specifies the sub-register number for a flag register operand. There are two sub-registers in the flag register. Each sub-register contains 16 flag bits. The selected flag sub-register is the source for predication if predication is enabled for the instruction. It is the destination to store conditional flag bits if conditional modifier is enabled for the instruction. The same flag sub-register can be both the predication source and conditional destination, if both predication and conditional modifier are enabled.
24:21	Src0.VertStride – Source 0 Vertical Stride. This field is the <i>VertStride</i> for src0 operand. It is ignored if src0 is an immediate operand.
20	Reserved: MBZ



Bits	Description
19:16	Src0.ChanSel[7:4] This is bits [7:4] of the <i>ChanSel</i> field for src0 operand.
15	Src0.AddrMode – Source 0 Address Mode. This field is the <i>AddrMode</i> for src0 operand. It is ignored if src0 is an immediate operand.
14:13	Src0.SrcMod – Source 0 Source Modifier. This field is the <i>SrcMod</i> for source operand src0.
12:5	Src0.RegNum – Source 0 Register Number This is the <i>RegNum</i> field for source operand src0. It is ignored if src0 is an immediate operand.
4	Src0.SubRegNum[4] This is the 16-byte aligned sub-register address for source operand src0. It is ignored if src0 is an immediate operand. Note: The recommended instruction syntax uses GRF sub-register numbers in units of element size, which the assembler translates to the appropriate value for this field. For example, using the F (Float) type the possible sub-register numbers in Align16 mode are 0 or 4, corresponding to 0 or 1 for this field.
3:0	Src0.ChanEn – Source 0 Channel Enable This is the <i>ChanEn</i> field for source operand src0. It is ignored if src0 is an immediate operand.

Instruction Source 0 Doubleword in Direct+Align1 mode

Bits	Description
31:26	Reserved: MBZ
25	FlagSubRegNum – Flag Sub-Register Number. This field specifies the sub-register number for a flag register operand.
24:21	Src0.VertStride – Source 0 Vertical Stride This is the <i>VertStride</i> field for src0 operand. It is ignored if src0 is an immediate operand.
20:18	Src0.Width. This is the <i>Width</i> field for source operand src0. It is ignored if src0 is an immediate operand.



Bits	Description
17:16	Src0.HorzStride. This is the <i>HorzStride</i> field for source operand src0. It is ignored if src0 is an immediate operand.
15	Src0.AddrMode – Source 0 Address Mode. This is the <i>AddrMode</i> for source operand src0. It is ignored if src0 is an immediate operand.
14:13	Src0.SrcMod – Source 0 Source Modifier. This is the <i>SrcMod</i> field for source operand src0. It is ignored if src0 is an immediate operand.
12:5	Src0.RegNum – Source 0 Register Number. This is the <i>RegNum</i> field for source operand src0. It is ignored if src0 is an immediate operand.
4:0	Src0.SubRegNum – Source 0 Sub-Register Number. This is the <i>SubRegNum</i> field for source operand src0. It is ignored if src0 is an immediate operand. Note: The recommended instruction syntax uses GRF sub-register numbers in units of element size, which the assembler translates to the appropriate value for this field.

Instruction Source 0 Doubleword in Indirect+Align16 mode

Bits	Description
31:26	Reserved: MBZ
25	FlagSubRegNum – Flag Sub-Register Number. This field specifies the sub-register number for a flag register operand.
24:21	Src0.VertStride – Source 0 Vertical Stride. This is the <i>VertStride</i> field for src0 operand. It is ignored if src0 is an immediate operand.
20	Reserved: MBZ
19:16	Src0.ChanSel[7:4] – Source 0 Channel Select. This is bits [7:4] of the <i>ChanSel</i> field for src0 operand. It is ignored if src0 is an immediate operand.
15	Src0.AddrMode – Source 0 Address Mode. This is the <i>AddrMode</i> for source operand src0. It is ignored if src0 is an immediate operand.
14:13	Src0.SrcMod – Source 0 Source Modifier. This is the <i>SrcMod</i> field for source operand src0. It is ignored if src0 is an immediate operand.



Bits	Description
12:10	Src0.AddrSubRegNum – Source 0 Address Sub-Register Number. This is the <i>AddrSubRegNum</i> field for source operand src0. It is ignored if src0 is an immediate operand.
9:4	Src0.AddrImm[9:4] – Source 0 Address Immediate. This contains the half-register aligned <i>AddrImm</i> field ((bits [9:4]) for src0. It is ignored if src0 is an immediate operand.
3:0	Src0.ChanEn – Source 0 Channel Enable . This is the <i>ChanEn</i> field for source operand src0. It is ignored if src0 is an immediate operand.

Instruction Source 0 Doubleword in Indirect+Align1 mode

Bits	Description
31:26	Reserved: MBZ
25	FlagSubRegNum – Flag Sub-Register Number. This field specifies the sub-register number for a flag register operand.
24:21	Src0.VertStride – Source 0 Vertical Stride. This is the <i>VertStride</i> field for src0 operand. It is ignored if src0 is an immediate operand.
20:18	Src0.Width. This is the <i>Width</i> field for source operand src0. It is ignored if src0 is an immediate operand.
17:16	Src0.HorzStride. This is the <i>HorzStride</i> field for source operand src0. It is ignored if src0 is an immediate operand.
15	Src0.AddrMode – Source 0 Address Mode. This is the <i>AddrMode</i> for source operand src0. It is ignored if src0 is an immediate operand.
14:13	Src0.SrcMod – Source 0 Source Modifier. This is the <i>SrcMod</i> field for source operand src0. It is ignored if src0 is an immediate operand.
12:10	Src0.AddrSubRegNum – Source 0 Address Sub-Register Number. This is the <i>AddrSubRegNum</i> field for source operand src0. It is ignored if src0 is an immediate operand.



Bits	Description
9:0	Src0.AddrImm – Source 0 Address Immediate. This is the byte aligned <i>AddrImm</i> field for src0. It is ignored if src0 is an immediate operand.

This section describes the field in DW2 and DW3 of the 3-src instruction format.

Instruction DW2 and DW3 3-Source

DW	Bits	Description
DW3	31:30	Reserved: MBZ
	29:22	Source2 Register Number. This field contains the register number for source2.
	21:19	Source2 Subregister Number. This field contains the sub-register number for source2. Note: The recommended instruction syntax uses GRF sub-register numbers in units of element size, which the assembler translates to the appropriate value for this field.
	18:11	Source2 Channel Select. This field contains the swizzle control for source2. See ChanSel in the Common Instruction Fields section for a description of the Source Swizzle encodings.
	10:10	Source2 Replication Control. This field controls replication for source2. See RepCtrl in the Common Instruction Fields section for a description of the Source Replication Control encodings.
	9:9	Reserved: MBZ
	8:1	Source1 Register Number. This field contains the register number for source1.
	0	Source1 Subregister Number. This field contains the sub-register number for source1. Note: The recommended instruction syntax uses GRF sub-register numbers in units of element size, which the assembler translates to the appropriate value for this field.
DW2	31:30	Source1 Subregister Number. This field contains the sub-register number for source1. Note: The recommended instruction syntax uses GRF sub-register numbers in units of element size, which the assembler translates to the appropriate value for this field.
	29:22	Source1 Channel Select. This field contains the swizzle control for source1. See ChanSel in the Common Instruction Fields section for a description of the Source Swizzle encodings.



DW	Bits	Description
	21:21	Source1 Replication Control. This field controls replication for source1. See RepCtrl in the Common Instruction Fields section for a description of the Source Replication Control encodings.
	20:20	Reserved: MBZ
	19:12	Source0 Register Number. This field contains the register number for source0.
	11:9	Source0 Subregister Number. This field contains the sub-register number for source0. Note: The recommended instruction syntax uses GRF sub-register numbers in units of element size, which the assembler translates to the appropriate value for this field.
	8:1	Source0 Channel Select. This field contains the swizzle control for source0. See ChanSel in the Common Instruction Fields section for a description of the Source Swizzle encodings.
	0:0	Source0 Replication Control. This field controls replication for source0. See RepCtrl in the Common Instruction Fields section for a description of the Source Replication Control encodings.

Instruction Source 1 Doubleword 3 (DW3)

Instruction Source 1 Doubleword 3 (DW3) contains the second source operand (src1) and is used to hold the 32-bit immediate source (imm32 as src0 or src1). *Instruction Source 1 Doubleword 3 (DW3)* and *Instruction Source 1 Doubleword 3 (DW3)* define the fields in this doubleword with the following exceptions:

- If src0 is an immediate operand, this doubleword contains **imm32** for src0.
- If src1 is an immediate operand, this doubleword contains **imm32** for src1.
- If the instruction is a send, bit 31 of this doubleword contains **EOT** field.
 - If src1 is immediate, the remaining 31 bits in this doubleword is **MsgDescpt31**.
 - If src1 is a register, src1 must be a0.0. The rest of this doubleword will be configured accordingly.
- If indirect address is supported for src1, *Instruction Source 1 Doubleword 3 (DW3)* and *Instruction Source 1 Doubleword 3 (DW3)* define the fields in DW3 for indirectly addressed src1 in Align16 and Align1 modes.



Instruction Source 1 Doubleword in Direct + Align16 mode

Bits	Description
31:25	Reserved: MBZ
24:21	Src1.VertStride – Source 1 Vertical Stride. This field is the <i>VertStride</i> for src1 operand. It is ignored if src1 is an immediate operand.
20	Reserved: MBZ
19:16	Src1.ChanSel[7:4] This contains bits [7:6] of the <i>ChanSel</i> field for src1 operand. It is ignored if src1 is an immediate operand.
15	Reserved: MBZ
14:13	Src1.SrcMod – Source 1 Source Modifier. This field is the <i>SrcMod</i> for src1 operand. It is ignored if src1 is an immediate operand.
12:5	Src1.RegNum. This field is the <i>RegNum</i> field for src1 operand. It is ignored if src1 is an immediate operand.
4	Src1.SubRegNum[4]. This field is bit [4] of the <i>SubRegNum</i> field for src1. It is ignored if src1 is an immediate operand. Note: The recommended instruction syntax uses GRF sub-register numbers in units of element size, which the assembler translates to the appropriate value for this field. For example, using the F (Float) type the possible sub-register numbers in Align16 mode are 0 or 4, corresponding to 0 or 1 for this field.
3:0	Src1.ChanEn – Source 1 Channel Enable. It is the channel enable field for src1. It is ignored if src1 is an immediate operand.



Instruction Source 1 Doubleword in Direct + Align1 mode

Bits	Description
31:25	Reserved: MBZ
24:21	Src1.VertStride – Source 1 Vertical Stride. This field is the <i>VertStride</i> for src1 operand. It is ignored if src1 is an immediate operand.
20:18	Src1.Width. This is the <i>Width</i> field for source operand src1. It is ignored if src1 is an immediate operand.
17:16	Src1.HorzStride. This is the <i>HorzStride</i> field for source operand src1. It is ignored if src1 is an immediate operand.
15	Reserved: MBZ
14:13	Src1.SrcMod – Source 1 Source Modifier. This field is the <i>SrcMod</i> for src1 operand. It is ignored if src1 is an immediate operand.
12:5	Src1.RegNum – Source 1 Register Number. This is the <i>RegNum</i> field for source operand src1. It is ignored if src1 is an immediate operand.
4:0	Src1.SubRegNum – Source 1 Sub-Register Number. This is the <i>SubRegNum</i> field for source operand src1. It is ignored if src1 is an immediate operand. Note: The recommended instruction syntax uses GRF sub-register numbers in units of element size, which the assembler translates to the appropriate value for this field.

Instruction Source 1 Doubleword in Indirect+Align16 mode

Bits	Description
31:25	Reserved: MBZ
24:21	Src1.VertStride – Source 1 Vertical Stride This is the <i>VertStride</i> field for src1 operand. It is ignored if src1 is an immediate operand.
20	Reserved: MBZ
19:16	Src1.ChanSel[7:4] – Source 1 Channel Select This is bits [7:4] of the <i>ChanSel</i> field for src1 operand.



Bits	Description
	It is ignored if src1 is an immediate operand.
15	Src1.AddrMode – Source 1 Address Mode This is the <i>AddrMode</i> for source operand src1. It is ignored if src1 is an immediate operand.
14:13	Src1.SrcMod – Source 1 Source Modifier This is the <i>SrcMod</i> field for source operand src1. It is ignored if src1 is an immediate operand.
12:10	Src1.AddrSubRegNum – Source 1 Address Sub-Register Number This is the <i>AddrSubRegNum</i> field for source operand src1. It is ignored if src1 is an immediate operand.
9:4	Src1.AddrImm[9:4] – Source 1 Address Immediate This contains the half-register aligned <i>AddrImm</i> field ((bits [9:4]) for src1. It is ignored if src1 is an immediate operand.
3:0	Src1.ChanEn – Source 1 Channel Enable This is the <i>ChanEn</i> field for source operand src1. It is ignored if src1 is an immediate operand.

Instruction Source 1 Doubleword in Indirect+Align1 mode

Bits	Description
31:25	Reserved: MBZ
24:21	Src1.VertStride – Source 1 Vertical Stride This is the <i>VertStride</i> field for src1 operand. It is ignored if src1 is an immediate operand.
20:18	Src1.Width This is the <i>Width</i> field for source operand src1. It is ignored if src1 is an immediate operand.
17:16	Src1.HorzStride



Bits	Description
	This is the <i>HorzStride</i> field for source operand src1. It is ignored if src1 is an immediate operand.
15	Src1.AddrMode – Source 1 Address Mode This is the <i>AddrMode</i> for source operand src1. It is ignored if src1 is an immediate operand.
14:13	Src1.SrcMod – Source 1 Source Modifier This is the <i>SrcMod</i> field for source operand src1. It is ignored if src1 is an immediate operand.
12:10	Src1.AddrSubRegNum – Source 1 Address Sub-Register Number This is the <i>AddrSubRegNum</i> field for source operand src1. It is ignored if src1 is an immediate operand.
9:0	Src1.AddrImm – Source 1 Address Immediate This is the byte aligned <i>AddrImm</i> field for src1. It is ignored if src1 is an immediate operand.

EU Compact Instructions

On receiving an instruction with bit 29 (CmptCtrl) set, HW recognizes it as a 64-bit compact instruction. Hardware then uses the index fields inside the compact instruction to lookup values in the associated compaction tables, then uses the table outputs along with other fields in the compact instruction to reconstruct the 128-bit native-sized instruction.

In some flow control instructions, IP offsets, such as the JIP and UIP instruction fields, are measured in 64-bit QWords. Thus a compact 64-bit instruction is 1 unit for IP offset calculations and a native 128-bit instruction is 2 units for IP offset calculations. However other instructions use a new relative offset format, a signed 32-bit offset in units of bytes.

The native 128-bit instruction format provides access to all instruction options. Only some instruction options and combinations of instruction options can be represented in the compact instruction formats.

Which native instructions can be represented as compact instructions and the details of the compact instruction formats and the compaction tables used may change with each processor generation.

In the following instruction format tables the Mapping Bits and Mapping Description columns describe the mappings into native instruction fields.



EU Compact Instruction Format

The following table describes the EU compact instruction format for DevHSW. For these processors, instructions with three source operands cannot be compacted.



GEN Compact Instruction Format

Bits	Size	Mapping Bits	Compact Name	Mapping Description
63:56	8	108:101 (Not Imm.) or 103:96 (Imm.)	Src1.RegNum	Src1.RegNum in 108:101 if not immediate. Imm32[7:0] in 103:96 if immediate.
55:48	8	76:69	Src0.RegNum	Src0.RegNum.
47:40	8	60:53	Dst.RegNum	Dst.RegNum.
39:35	5	120:109 (Not Imm.) or 127:104 (Imm.)	Src1Index	Lookup one of 32 12-bit values. If not an immediate operand, maps to bits 120:109, covering the Src1.AddrMode, Src1.ChanSel[7:4], Src1.HorzStride, Src1.SrcMod, Src1.VertStride, and Src1.Width bit fields. If an immediate operand, does not do any lookup. The 5-bit value directly maps to bits 108:104 (Imm32[12:8]) and the upper bit (bit 39 in the compact format, bit 108 in the native format) is replicated to provide bits 127:109 (Imm32[31:13]) in the native format.
34:30	5	88:77	Src0Index	Lookup one of 32 12-bit values. That value is used (from MSB to LSB) for the Src0.AddrMode, Src0.ChanSel[7:4], Src0.HorzStride, Src0.SrcMod, Src0.VertStride, and Src0.Width bit fields. Note that this field spans a DWord boundary within the QWord compacted instruction.
29	1	29	CmptCtrl	Compaction Control. The same in both the compact and native formats: 0: Regular instruction, not compacted. 1: Compacted instruction.
28	1	[HSW]: Not mapped.	[HSW]: Reserved	[HSW]: Not mapped. MBZ.
27:24	4	27:24	CondModifier	CondModifier. The same in both the compact and native formats.
23	1	28	AccWrCtrl	AccWrCtrl.
22:18	5	100:96, 68:64, 52:48	SubRegIndex	Lookup one of 32 15-bit values. That value is used (from MSB to LSB) for various fields for Src1, Src0, and Dst, including ChanEn/ChanSel, SubRegNum, and AddrImm[4] or AddrImm[4:0], depending on AddrMode and AccessMode.
17:13	5	63:61, 46:32	DataTypeIndex	Lookup one of 32 18-bit values. That value is used (from MSB to LSB) for the Dst.AddrMode, Dst.HorzStride, Dst.DstType, Dst.RegFile, Src0.SrcType, Src0.RegFile, Src1.SrcType, and Src1.RegType bit fields.
12:8	5	[HSW]: 90:89, 31, 23:8	ControlIndex	HSW: Lookup one of 32 19-bit values. That value is used (from MSB to LSB) for the FlagRegNum, FlagSubRegNum, Saturate, ExecSize, PredInv, PredCtrl, ThreadCtrl, QtrCtrl, DepCtrl, MaskCtrl, and AccessMode bit fields.
6:0	7	6:0	Opcode	Opcode. The same in both the compact and native formats.



The following diagram is an alternate presentation of the [HSW] compact instruction format.

GEN Compact Instruction Format

DW #	Instr Bits Alloc	High Bit	Low Bit	Instr Bits Used	Description	Bits in 128bits Format	Description (Imm, Src0 or Src1)	Bits in 128bits Format (Imm, Src0 or Src1)
1	8	63	56	8	Src1 RegNum	[108:101]	Imm[23:16] Imm[7:0]	[119:112] [103:96]
	8	55	48	8	Src0 RegNum	[76:69]	Src0 RegNum	[76:69]
	8	47	40	8	Dst RegNum	[60:53]	Dst RegNum	[60:53]
	5	39	35	5	Src1Index[4:0]	[120:109]	Src1Index[4:0]	[127:120] [111:104]
	3	34	32	3				
0	2	31	30	2	Src0Index[4:0]	[88:77]	Src0Index[4:0]	[88:77]
	1	29	29	1	CmptCtrl	[29]	CmptCtrl	[29]
	1	28	28	1	Reserved		Reserved	
	4	27	24	4	CondModifier	[27:24]	CondModifier	[27:24]
	1	23	23	1	AccWrCtrl	[28]	AccWrCtrl	[28]
	5	22	18	5	SubRegIndex[4:0]	[100:96] [68:64] [52:48]	SubRegIndex[4:0]	[100:96] [68:64] [52:48]
	5	17	13	5	DataTypeInfo[4:0]	[63:61] [46:32]	DataTypeInfo[4:0]	[63:61] [46:32]
	5	12	8	5	ControlIndex[4:0]	[90:89] [31] [23:8]	ControlIndex[4:0]	[90:89] [31] [23:8]
	1	7	7	1	DebugCtrl	[30]	DebugCtrl	[30]
	7	6	0	7	Opcode	[6:0]	Opcode	[6:0]

EU Instruction Compaction Tables

The following four tables describe the mappings for the ControlIndex, DataTypeIndex, SubRegIndex, Src0Index, and Src1Index fields in the compact instruction format for HSW.

ControlIndex Compact Instruction Field Mappings

ControlIndex	19-Bit Mapping	Mapped Meaning
0	0000000000000000010	Align1 We (1) f0.0
1	0000100000000000000	Align1 (4) f0.0
2	0000100000000000001	Align16 (4) f0.0
3	0000100000000000010	Align1 We (4) f0.0
4	0000100000000000011	Align16 We (4) f0.0
5	0000100000000000100	Align1 NoDDClr (4) f0.0
6	0000100000000000101	Align16 NoDDClr (4) f0.0
7	0000100000000000111	Align16 We NoDDClr (4) f0.0
8	0000100000000000100	Align1 NoDDChk (4) f0.0
9	0000100000000000101	Align16 NoDDChk (4) f0.0
10	00001000000000001101	Align16 NoDDClr, NoDDChk (4) f0.0
11	0000110000000000000	Align1 Q1 (8) f0.0
12	0000110000000000001	Align16 Q1 (8) f0.0
13	0000110000000000010	Align1 We Q1 (8) f0.0
14	0000110000000000011	Align16 We Q1 (8) f0.0
15	0000110000000000100	Align1 NoDDClr Q1 (8) f0.0
16	0000110000000000101	Align16 NoDDClr Q1 (8) f0.0



ControlIndex	19-Bit Mapping	Mapped Meaning
17	0000110000000000111	Align16 We NoDDClr Q1 (8) f0.0
18	0000110000000001001	Align16 NoDDChk Q1 (8) f0.0
19	0000110000000001101	Align16 NoDDClr, NoDDChk Q1 (8) f0.0
20	0000110000000010000	Align1 Q2 (8) f0.0
21	0000110000100000000	Align1 Q1 +f.xyzw (8) f0.0
22	0001000000000000000	Align1 H1 (16) f0.0
23	0001000000000000010	Align1 We H1 (16) f0.0
24	0001000000000000100	Align1 NoDDClr H1 (16) f0.0
25	0001000000100000000	Align1 H1 +f.xyzw (16) f0.0
26	0010110000000000000	Align1 Q1 (8) .sat f0.0
27	0010110000000010000	Align1 Q2 (8) .sat f0.0
28	0011000000000000000	Align1 H1 (16) .sat f0.0
29	0011000000100000000	Align1 H1 +f.xyzw (16) .sat f0.0
30	0101000000000000000	Align1 H1 (16) f0.1
31	0101000000100000000	Align1 H1 +f.xyzw (16) f0.1

DataTypeInfo Compact Instruction Field Mappings

DataTypeInfo	18-Bit Mapping	Mapped Meaning
0	0010000000000000001	r:ud a:ud a:ud <1> dir
1	001000000000100000	a:ud r:ud a:ud <1> dir
2	001000000000100001	r:ud r:ud a:ud <1> dir
3	001000000001100001	r:ud i:ud a:ud <1> dir
4	001000000010111101	r:f r:d a:ud <1> dir
5	001000001011111101	r:f i:vf a:ud <1> dir
6	001000001110100001	r:ud r:f a:ud <1> dir
7	001000001110100101	r:d r:f a:ud <1> dir
8	001000001110111101	r:f r:f a:ud <1> dir
9	001000010000100001	r:ud r:ud r:ud <1> dir
10	001000110000100000	a:ud r:ud i:ud <1> dir
11	001000110000100001	r:ud r:ud i:ud <1> dir
12	001001010010100101	r:d r:d r:d <1> dir
13	001001110010100100	a:d r:d i:d <1> dir
14	001001110010100101	r:d r:d i:d <1> dir
15	001111001110111101	r:f r:f a:f <1> dir
16	001111011110011101	r:f a:f r:f <1> dir
17	001111011110111100	a:f r:f r:f <1> dir



Data Type Index	18-Bit Mapping	Mapped Meaning
18	001111011110111101	r:f r:f r:f <1> dir
19	001111111110111100	a:f r:f i:f <1> dir
20	000000001000001100	a:w a:ub a:ud <0> dir
21	001000000000111101	r:f r:ud a:ud <1> dir
22	001000000010100101	r:d r:d a:ud <1> dir
23	001000010000100000	a:ud r:ud r:ud <1> dir
24	001001010010100100	a:d r:d r:d <1> dir
25	001001110010000100	a:d a:d i:d <1> dir
26	001010010100001001	r:uw a:uw r:uw <1> dir
27	001101111110111101	r:f r:f i:vf <1> dir
28	001111111110111101	r:f r:f i:f <1> dir
29	001011110110101100	a:w r:w i:w <1> dir
30	001010010100101000	a:uw r:uw r:uw <1> dir
31	001010110100101000	a:uw r:uw i:uw <1> dir

SubRegIndex Compact Instruction Field Mappings

SubRegIndex	15-Bit Mapping	Mapped Meaning
0	000000000000000	0 0 0
1	000000000000001	0.x 0.xx 0.xx
2	00000000001000	8 0 0
3	00000000001111	0.xyzw 0.xx 0.xx
4	00000000010000	16 0 0
5	000000010000000	0 4 0
6	000000100000000	0 8 0
7	000000110000000	0 12 0
8	000001000000000	0 16 0
9	000001000010000	16 16 0
10	000001010000000	0 20 0
11	001000000000000	0 0 4
12	001000000000001	0.x 0.xx 0.xy
13	001000010000001	0.x 0.xy 0.xy
14	001000010000010	0.y 0.xy 0.xy
15	001000010000011	0.xy 0.xy 0.xy
16	001000010000100	0.z 0.xy 0.xy
17	001000010000111	0.xyz 0.xy 0.xy
18	001000010001000	0.w 0.xy 0.xy



SubRegIndex	15-Bit Mapping	Mapped Meaning
19	001000010001110	0.yzw 0.xy 0.xy
20	001000010001111	0.xyzw 0.xy 0.xy
21	001000110000000	0 12 4
22	001000111101000	0.w 0.ww 0.xy
23	010000000000000	0 0 8
24	010000110000000	0 12 8
25	011000000000000	0 0 12
26	011110010000111	0.xyz 0.xy 0.ww
27	100000000000000	0 0 16
28	101000000000000	0 0 20
29	110000000000000	0 0 24
30	111000000000000	0 0 28
31	111000000011100	28 0 28

Src0Index or Src1Index Compact Instruction Field Mappings

Src0Index or Src1Index	12-Bit Mapping	Mapped Meaning
0	000000000000	dir <0;1,0>
1	000000000010	(-) dir <0;1,0>
2	000000010000	dir <0;>.zx
3	000000010010	(-) dir <0;>.zx
4	000000011000	dir <0;>.wx
5	000000100000	dir <0;>.xy
6	000000101000	dir <0;>.yy
7	000001001000	dir <0;4,1>
8	000001010000	dir <0;>.zz
9	000001110000	dir <0;>.zw
10	000001111000	dir <0;8,4> / dir <0;>.ww
11	001100000000	dir <4;>.xx
12	001100000010	(-) dir <4;>.xx
13	001100001000	dir <4;>.yx
14	001100010000	dir <4;>.zx
15	001100010010	(-) dir <4;>.zx
16	001100100000	dir <4;>.xy
17	001100101000	dir <4;>.yy
18	001100111000	dir <4;>.wy



Src0Index or Src1Index	12-Bit Mapping	Mapped Meaning
19	001101000000	dir <4;4,0>
20	001101000010	(-) dir <4;4,0>
21	001101001000	dir <4;>.yz
22	001101010000	dir <4;>.zz
23	001101100000	dir <4;>.xw
24	001101101000	dir <4;>.yw
25	001101110000	dir <4;>.zw
26	001101110001	(abs) dir <4;>.zw
27	001101111000	dir <4;>.ww
28	010001101000	dir <8;8,1>
29	010001101001	(abs) dir <8;8,1>
30	010001101010	(-) dir <8;8,1>
31	010110001000	dir <16;16,1>

Opcode Encoding

Byte 0 of the 128-bit instruction word contains the opcode. The opcode uses 7 bits. Bit location 7 in byte 0 is reserved for future opcode extension.

The opcodes are encoded and organized into five groups based on the type of operations: Special instructions, move/logic instructions (opcode=00xxxxb), flow control instructions (opcode=010xxxxb), miscellaneous instructions (opcode=011xxxxb), parallel arithmetic instructions (opcode=100xxxxb), and vector arithmetic instructions (opcode=101xxxxb). Opcodes 110xxxxb are reserved.

Note: Opcodes appear in the overall [Instruction Set Summary Table](#) as well. The following subsections still serve the purpose of describing various instruction groups.

Move and Logic Instructions

This instruction group has an opcode format of 00xxxxb.

- The opcodes for move instructions (*mov*, *sel* and *movi*) share the common 5 MSBs in the form of 00000xxb.
- The opcodes for logic instructions (*not*, *and*, *or*, and *xor*) share the common 5 MSBs in the form of 00001xxb.
- The opcodes for shift instructions (*shr*, *shl*, and *asr*) share the common 4 MSBs in the form of 0001xxxxb. Bit 2 indicates arithmetic or logic shift (0 = logic, 1 = arithmetic). Bit 1 is always 0 (which is reserved for future extension to support rotation shift as 0 = shift, 1 = rotate). Bit 0 indicates the shift direction (0 = right, 1 = left).



- The opcodes for compare instructions (*cmp* and *cmpn*) share the common 6 MSBs in the form of 001000xb. Bit 0 indicates whether it is a normal compare, *cmp*, or a special compare-NaN, *cmpn*.

Move and Logic Instructions

Opcode		Instruction	Description	#src	#dst
dec	hex				
1	0x01	mov	Component-wise move	1	1
2	0x02	sel	Component-wise selective move based on predication	2	1
3	0x03	movi	Fast component-wise indexed move	1	1
4	0x04	not	Component-wise one's complement (bitwise not)	1	1
5	0x05	and	Component-wise logical AND (bitwise and)	2	1
6	0x06	or	Component-wise logical OR (bitwise or)	2	1
7	0x07	xor	Component-wise logical XOR (bitwise xor)	2	1
8	0x08	shr	Component-wise logical shift right	2	1
9	0x09	shl	Component-wise logical shift left	2	1
10	0x0A	dim	Double Precision Floating Point Immediate Data Move	1	1
12	0x0B	<i>Reserved</i>			
12	0x0C	asr	Component-wise arithmetic shift right	2	1
13	0x0D	<i>Reserved</i>			
16	0x10	cmp	Component-wise compare, store condition code in destination	2	1
17	0x11	cmpn	Component-wise compare-NaN, store condition code in destination	2	1
18	0x12	<i>Reserved</i>			
18	0x12	<i>csel</i>	Component-wise selective move based on result of compare	3	1
19	0x13	<i>Reserved</i>		1	1
19	0x13	<i>f32tof16</i>	Single precision float to half precision float conversion		



Opcode		Instruction	Description	#src	#dst
dec	hex				
20	0x14	f16to32	Half precision float to single precision float conversion		
21	0x15	<i>Reserved</i>			
22	0x16	<i>Reserved</i>			
23	0x17	bfrev	Reverse bits	1	1
24	0x18	bfe	Bitfield exact	3	1
25	0x19	bfi1	Bitfield insert macro instruction 1, generate mask	2	1
26	0x1A	bfi2	Bitfield insert macro instruction 2, generate mask	2	1
27-31	0x1B-0x1F	<i>Reserved</i>			

Flow Control Instructions

This instruction group has an opcode format of 010xxxxb.

Flow Control Instructions

Opcode		Instruction	Description	#src	#dst
dec	hex				
32	0x20	jmp <i>i</i>	Jump indexed	1	0
33	0x21	brd	Branch - Diverging	1	0
34	0x22	if	If	0/2	0
35	0x23	brc	Branch - Converging	1	-
36	0x24	else	Else	1	0
37	0x25	endif	End if	0	0



Opcode		Instruction	Description	#src	#dst
dec	hex				
38	0x26	case	Case – Inside Switch block	0/2	0
39	0x27	while	While	1	0
40	0x28	break	Break	1	0
41	0x29	cont	Continue	1	0
42	0x2A	halt	Halt	1	0
43	0x2B	calla	Subroutine call absolute	1	1
44	0x2C	call	Subroutine call	1	1
45	0x2D	return	Subroutine return	1	1
46	0x2E	Reserved			
47	0x2F	Reserved			

Miscellaneous Instructions

This instruction group has an opcode format of 011xxxxb.

Miscellaneous Instructions

Opcode		Instruction	Description	#src	#dst
dec	hex				
48	0x30	wait	Wait for (external) notification	1	0
49	0x31	send	Send	1	1
50	0x32	sendc	Conditional Send (based on TDR)	1	1
53-55	0x35-0x37	Reserved			
56	0x38	math	Math functions for extended math pipeline	1/2	1/2
57-63	0x39-0x3F	Reserved			



Parallel Arithmetic Instructions

This instruction group has an opcode format of 100xxxxb.

Parallel Arithmetic Instructions

Opcode		Instruction	Description	#src	#dst
dec	hex				
64	0x40	add	Component-wise addition	2	1
65	0x41	mul	Component-wise multiply	2	1
66	0x42	avg	Component-wise average of the two source operands	2	1
67	0x43	frc	Component-wise floating point truncate-to-minus-infinity fraction	1	1
68	0x44	rndu	Component-wise floating point rounding up (ceiling)	1	1
69	0x45	rndd	Component-wise floating point rounding down (floor)	1	1
70	0x46	rnde	Component-wise floating point rounding toward nearest even	1	1
71	0x47	rndz	Component-wise floating point rounding toward zero	1	1
72	0x48	mac	Component-wise multiply accumulate	2	1
73	0x49	mach	multiply accumulate high	2	1
74	0x4A	lzd	leading zero detection	1	1
75	0x4B	<i>fbh</i> <i>[DevIVB+]</i>	Find first 1 for UD from msb side, or first 1/0 for D.	1	1
76	0x4C	<i>fbl</i> <i>[DevIVB+]</i>	First first 1 for UD from lsb side	1	1
77	0x4D	<i>cbit</i> <i>[DevIVB+]</i>	Count bits set	1	1
78	0x4E	<i>addc</i> <i>[DevIVB+]</i>	Integer add with carry	2	1 + acc.



Opcode		Instruction	Description	#src	#dst
dec	hex				
79	0x4F	subb [DevIVB+]	integer subtract with borrow	2	1 + acc.
75- 79	0x4B- 0x4F	Reserved			

Vector Arithmetic Instructions

- This instruction group has an opcode format of 101xxxxb.

Vector Arithmetic Instructions

Opcode		Instruction	Description	#src	#dst
dec	hex				
80	0x50	sad2	2-wide sum of absolute difference	2	1
81	0x51	sada2	2-wide sad accumulate	2	1
82- 83	0x52- 0x53	<i>reserved</i>			
84	0x54	dp4	4-wide dot product for 4-vector	2	1
85	0x55	dph	4-wide homogenous dot product for 4-vector	2	1
86	0x56	dp3	3-wide dot product for 4-vector	2	1
87	0x57	dp2	2-wide dot product for 4-vector	2	1
88	0x58	<i>reserved</i>			
89	0x59	line	Component-wise line equation computation (a multiply-add)	2	1
90	0x5A	pln	Component-wise floating point plane equation computation (a multiply-multiply-add)	2	1
91	0x5B	fma(mad)	Component-wise floating point mad computation (a multiple-add)	3	1
92	0x5C	lrp	Component-wise floating point lrp computation (blend)	3	1
93	0x5D	<i>reserved</i>			
94- 95	0x5E- 0x5F	<i>reserved</i>			



Special Instructions

There are two special instructions, namely, *nop* (opcode = 0x7E) and *illegal* (opcode = 0x00).

- *Nop* instruction may be used for instruction padding in memory between two normal instructions to force alignment or to introduce instruction execution delay. Currently, there is no need for between-instruction padding.
- *Illegal* instruction may be used for instruction padding in memory outside the normal instruction sequence such as before or after the kernel program as well as between subroutines.
- *Nop* and *illegal* instructions do not have source operands or destination operand. Therefore, they do not implicitly update the accumulator register. They cannot be compressed.

Special Instructions

Opcode		Instruction	Description	#src	#dst
dec	hex				
0	0x00	illegal	Illegal instruction	0	0
96-124	0x60-0x7D	<i>Reserved</i>			
126	0x7E	nop	No-op	0	0
127	0x7F	<i>Reserved</i>	(may be used as an extension code)		



Native Instruction BNF

The Backus-Naur Form (BNF) grammar identifies the assembly language syntax, which is native to the hardware. It does not include intelligent defaults, assembler pragmas, etc.

Instruction Groups

<Instruction> ::= <UnaryInstruction>

|<BinaryAccInstruction>

|<BinaryInstruction>

|<TriInstruction>

|<JumpInstruction>

|<BranchLoopInstruction>

|<ElseInstruction>

|<BreakInstruction>

|<MaskControlInstruction

|<TriInstruction2>

|<CallInstruction>

|<BranchConvInstruction>

|<BranchDivInstruction>

|<MathInstruction>

|<SyncInstruction>

|<SpecialInstruction>

<UnaryInstruction> ::= <Predicate> <UnaryInst> <ExecSize> dst <SrcAccImm> <InstOptions>

<UnaryInst> ::= <UnaryOp> <ConditionalModifier> <Saturate>

<UnaryOp> ::= *mov* | *fr*c | *rndu* | *rndd* | *rnde* | *rndz* | *not* | *lzd*

<BinaryInstruction> ::= <Predicate> <BinaryInst> <ExecSize> dst <Src> <SrcImm> <InstOptions>

<BinaryInst> ::= <BinaryOp> <ConditionalModifier> <Saturate>

<BinaryOp> ::= **mul** | **mac** | **mach** | **line** | **pln**

sad2 | **sada2** | **dp4** | **dph** | **dp3** | **dp2** | **lrp** | **bfi1** | **addc** | **subb**

<BinaryAccInstruction> ::= <Predicate> <BinaryAccInst> <ExecSize> dst <SrcAcc> <SrcImm>
<InstOptions>

<BinaryAccInst> ::= <BinaryAccOp> <ConditionalModifier> <Saturate>

<BinaryAccOp> ::= **avg** | **add** | **sel**

and | **or** | **xor**

shr | **shl** | **asr**



|cmp | cmpn

<TriInstruction> ::= <Predicate> <TriInst> <ExecSize> <PostDst> <CurrDst> <TriSrc> <MsgDesc>
<InstOptions>

<TriInst> ::= <TriOp> <ConditionalModifier> <Saturate>

<TriOp> ::= **send**

<TriInstruction2> ::= <Predicate> <TriInst2> <ExecSize> dst <Src> <Src> <Src> <InstOptions>

<TriInst2> ::= <TriOp> <ConditionalModifier> <Saturate>

, <TriOp> ::= *bfe* | *bfi2* | *mad*

<BranchConvInstruction> ::= <Predicate> <BranchConvOp> <ExecSize> <RelativeLocation2>

<BranchConvOp> ::= *brc*

<BranchDivInstruction> ::= <Predicate> <BranchDivOp> <ExecSize> <RelativeLocation3>

<BranchDivOp> ::= *brd*

<CallInstruction> ::= <Predicate> <CallOp> <ExecSize> dst <RelativeLocation2>

<CallOp> ::= *call* | *CALLA*

<MathInstruction> ::= <Predicate> <MathInst> <ExecSize> <Dst> <Src> <Src> <FC>

<MathInst> ::= <MathOp> <Saturate>

<MathOp> ::= *math*

<FC> ::= **INV** | **LOG** | **EXP** | **SQRT** | **RSQ** | **POW** | **SIN** | **COS** | **INT DIV**

<JumpInstruction> ::= <JumpOp> <RelativeLocation2>

<JumpOp> ::= **jmp** | **jmpb**

<BranchLoopInstruction> ::= <Predicate> <BranchLoopOp> <RelativeLocation>

<BranchLoopOp> ::= **if** | **iff** | **while**

<ElseInstruction> ::= <ElseOp> <RelativeLocation>

<ElseOp> ::= **else**

<BreakInstruction> ::= <Predicate> <BreakOp> <LocationStackCtrl>

<BreakOp> ::= **break** | **cont** | **halt**

<SyncInstruction> ::= <Predicate> <SyncOp> <NotifyReg>

<SyncOp> ::= **wait**

<SpecialInstruction> ::= **do** | **endif** | **nop** | **illegal**



Source Register

Source with Accumulator Access and with Immediate

<SrcAccImm> ::= <SrcAcc>

|<Imm32> <SrcImmType>

<SrcAcc> ::= <DirectSrcAccOperand>

|<IndirectSrcOperand>

<DirectSrcAccOperand> ::= <DirectSrcOperand>

|<SrcArcOperandEx>

|<AccReg> <SrcType>

<SrcArcOperandEx> ::= <FlagReg> <Region> <SrcType>

|<AddrReg> <Region> <SrcType>

|<ControlReg>

|<StateReg>

|<NotifyReg>

|<IPReg>

|<NullReg>

|<ChannelEnableReg>

|<ThreadControlReg>

|<PerformanceReg>

<IndirectSrcOperand> ::= <SrcModifier> <IndirectGenReg> <IndirectRegion> <Swizzle> <SrcType>

Source without Accumulator Access

<Src> ::= <DirectSrcOperand>

|<IndirectSrcOperand>

<DirectSrcOperand> ::= <SrcModifier> <DirectGenReg> <Region> <Swizzle> <SrcType>

|<SrcArcOperandEx>

<TriSrc> ::= <SrcModifier> <DirectGenReg> <Region> <Swizzle> <SrcType>

|<NullReg>

<MsgDesc> ::= <ImmDesc>



|<Reg32>

<Reg32> ::= <DirectGenReg> <Region> <SrcType>

Source without Accumulator Access or IP Access

<SrcImm> ::= <DirectSrcOperand>

|<Imm32> <SrcImmType>

Address Registers

<AddrParam> ::= <AddrReg> <ImmAddrOffset>

<ImmAddrOffset> ::=

| , <ImmAddrNum>

Register Files and Register Numbers

Note: The recommended instruction syntax uses sub-register numbers within the GRF in units of actual data element size, corresponding to the data type used. For example for the F (Float) type, the assembler syntax uses sub-register numbers 0 to 7, corresponding to sub-register byte addresses of 0 to 28 in steps of 4, the element size.

<DirectGenReg> ::= <GenRegFile> <GenRegNum> <GenSubRegNum>

<IndirectGenReg> ::= <GenRegFile> [<AddrParam>]

<GenRegFile> ::= **r**

<GenRegNum> ::= =**0...127**

<GenSubRegNum> ::= =

| .0...3 //incase of DF

| **.0...7**

| **.0...15**

| **.0...31**

<DirectMsgReg> ::= <DirectAlignedMsgReg> <MsgSubRegNum>

<DirectAlignedMsgReg> ::= <MsgRegFile> <MsgRegNum>

<IndirectMsgReg> ::= <MsgRegFile> [<AddrParam>]

<MsgRegFile> ::= **m**

<MsgRegNum> ::= =**0...15**

<MsgSubRegNum> ::= = <GenSubRegNum>



<AddrReg> ::= <AddrRegFile> <AddrSubRegNum>
<AddrRegFile> ::= **a0**
<AddrSubRegNum> ::= =
| **.07**
<AccReg> ::= **acc** <AccRegNum> <AccSubRegNum>
<AccRegNum> ::= = **0 | 1**
<AccSubRegNum> ::= = <GenSubRegNum>
<FlagReg> ::= *f* <FlagRegNum> <FlagSubRegNum>
<FlagRegNum> ::= = *0 | 1*
<FlagReg> ::= **f0** <FlagSubRegNum>
<FlagSubRegNum> ::= =
| **.0...1**
<NotifyReg> ::= **n** <NotifyRegNum>
<NotifyRegNum> ::= = **0...2**
<StateReg> ::= **sr0** <StateSubRegNum>
<StateSubRegNum> ::= = **0... 1**
<ControlReg> ::= **cr0** <ControlSubRegNum>
<ControlSubRegNum> ::= = **02**
<IPReg> ::= **ip**
<NullReg> ::= **null**
<ThreadControlReg> ::= *tdr0* <ThreadCntrlSubRegNum>
<ThreadCntrlSubRegNum> ::= = *.0...7*
<PerformanceReg> ::= *tm0*
<ChannelEnableReg> ::= = *ce0.0*

Relative Location and Stack Control

<RelativeLocation> ::= <imm16>
<RelativeLocation2> ::= <imm32> | <reg32>
<RelativeLocation3> ::= <imm16> | <reg32>
<LocationStackCtrl> ::= <imm32>



Regions

$\langle \text{DstRegion} \rangle ::= \langle \langle \text{HorzStride} \rangle \rangle$
 $\langle \text{IndirectRegion} \rangle ::= \langle \text{Region} \rangle \mid \langle \text{RegionWH} \rangle \mid \langle \text{RegionV} \rangle$
 $\langle \text{Region} \rangle ::= \langle \langle \text{VertStride} \rangle \rangle ; \langle \text{Width} \rangle , \langle \text{HorzStride} \rangle$
 $\langle \text{RegionWH} \rangle ::= \langle \langle \text{Width} \rangle , \langle \text{HorzStride} \rangle \rangle$
 $\langle \text{RegionV} \rangle ::= \langle \langle \text{VertStride} \rangle \rangle$
 $\langle \text{VertStride} \rangle ::= \mathbf{0 \mid 1 \mid 2 \mid 4 \mid 8 \mid 16 \mid 32}$
 $\langle \text{Width} \rangle ::= \mathbf{1 \mid 2 \mid 4 \mid 8 \mid 16}$
 $\langle \text{HorzStride} \rangle ::= \mathbf{0 \mid 1 \mid 2 \mid 4}$

Types

$\langle \text{SrcType} \rangle ::= \mathbf{:df \mid :f \mid :ud \mid :d \mid :uw \mid :w \mid :ub \mid :b}$
 $\langle \text{SrcImmType} \rangle ::= \langle \text{SrcType} \rangle \mid \mathbf{:v \mid :vf \mid :uv}$
 $\langle \text{DstType} \rangle ::= \langle \text{SrcType} \rangle$

Write Mask

$\langle \text{WriteMask} \rangle ::=$
 $\mid . \mathbf{x} \mid . \mathbf{y} \mid . \mathbf{z} \mid . \mathbf{w}$
 $\mid . \mathbf{xy} \mid . \mathbf{xz} \mid . \mathbf{xw} \mid . \mathbf{yz} \mid . \mathbf{yw} \mid . \mathbf{zw}$
 $\mid . \mathbf{xyz} \mid . \mathbf{xyw} \mid . \mathbf{xzw} \mid . \mathbf{yzw}$
 $\mid . \mathbf{xyzw}$

Swizzle Control

$\langle \text{Swizzle} \rangle ::=$
 $\mid . \langle \text{ChanSel} \rangle$
 $\mid . \langle \text{ChanSel} \rangle \langle \text{ChanSel} \rangle \langle \text{ChanSel} \rangle \langle \text{ChanSel} \rangle$
 $\langle \text{ChanSel} \rangle ::= \mathbf{x \mid y \mid z \mid w}$

Immediate Values

$\langle \text{ImmAddrNum} \rangle ::= \mathbf{-512 \dots 511}$
 $\langle \text{Imm64} \rangle ::= \mathbf{0.0 \dots \pm 1.0 * 2^{-1024} \dots 1023 \mid 0 \dots 264-1 \mid -263 \dots 263-1}$
 $\langle \text{Imm32} \rangle ::= \mathbf{0.0 \dots \pm 1.0 * 2^{-128} \dots 127 \mid 0 \dots 2^{32}-1 \mid -2^{31} \dots 2^{31}-1}$



<Imm16> ::= **0**... **2¹⁶-1** | **-2¹⁵... 2¹⁵-1**

<ImmDesc> ::= **0**... **2³²-1**

Predication and Modifiers

Instruction Predication

<Predicate> ::=

| (<PredState> <FlagReg> <PredCntrl>)

<PredState> ::=

| +

| -

<PredCntrl> ::=

| .x | .y | .z | .w

| .any2h | .all2h

| .any4h | .all4h

| .any8h | .all8h

| .any16h | .all16h

| .anyv | .allv

| .any32h | .all32h

Source Modification

<SrcModifier> ::=

| -

| (abs)

| - (abs)

Instruction Modification

<ConditionalModifier> ::=

| <CondMod> . <FlagReg>

<CondMod> ::= .z | .e | .nz | .ne | .g | .ge | .l | .le | .o | .r | .u

<Saturate> ::=

| .sat

Execution Size

<ExecSize> ::= (<NumChannels>)



<NumChannels> ::= **1 | 2 | 4 | 8 | 16 | 32**

Instruction Options

<InstOptions> ::=

| { <InstOption> }

| { <InstOption> <InstOptionEx> }

<InstOptionEx> ::=

| , <InstOption> <InstOptionEx>

<InstOption> ::= <AccessMode>

| <AccWrCtrl>

| <ComprCtrl>

| <DependencyCtrl>

| <MaskCtrl>

| <SendCtrl>

| <ThreadCtrl>

<AccessMode> ::= **Align1 | Align16**

<AccWrCtrl> ::= **AccWrEn**

<ComprCtrl> ::= **SecHalf | Compr**

<DependencyCtrl> ::= **NoDDChk | NoDDClr**

<MaskCtrl> ::= **NoMask**

<SendCtrl> ::= **EOT**

<ThreadCtrl> ::= **Switch**

| **Atomic**

Note for Assembler: Compression control **Compr** has a direct map to the binary instruction word. It may be omitted if the Assembler can determine whether an instruction is compressible.



Instruction Set Summary Tables

The columns in the following tables specify instruction mnemonics, hex opcodes, full names, instruction groups, processor generation (where blank means available for DevSNB+), the number of source operands, whether the instruction supports predication, any support for source modifiers, an indication of supported data types, whether the instruction supports saturation, and any support for conditional modifiers.

See the separate [Accumulator Restrictions](#) table for information about how instructions are allowed to use accumulators.

With a dozen columns in these tables, some terse notation is used, like IVB+ for DevIVB+ in the Gen (processor generation) column. If the Gen column is blank, an instruction is supported for DevSNB+, all generations implemented or designed so far, from Sandy Bridge forward.

N and Y indicate No (no support for a feature) and Yes (full support for a feature) respectively.

A SrcMod (source modifier) value of Y indicates that a numeric source modifier is allowed, optionally specifying absolute value, negation, or a forced negative value. The value N indicates no source modifier support.

A SrcMod value of ** indicates a numeric source modifier.

In the Src Types and Dst Type columns, Int means any integer type and * means such an extensive list of types that you must refer to the detailed instruction description.



Instruction Set Summary Table A to B (Listed by Instruction Mnemonic)

Mnem.	Hex Opcode	Name	Group	Gen	Srcs	Pred?	SrcMod	Src Types	Dst Type	Sat?	CondMod?
<i>add</i>	40	Addition	Parallel Arithmetic		2	Y	Y	*	*	Y	Y
<i>addc</i>	4E	Integer Addition with Carry	Parallel Arithmetic		2	Y	N	UD	UD	N	Y
<i>and</i>	05	Logic And	Move and Logic		2	Y	**	Int	Int	N	Equality only
<i>asr</i>	12	Arithmetic Shift Right	Move and Logic		2	Y	Y	Int	Int	Y	Y
<i>avg</i>	42	Average	Parallel Arithmetic		2	Y	Y	B, UB W, UW D, UD	B, UB W, UW D, UD	Y	Y
<i>bfe</i>	18	Bit Field Extract	Move and Logic		3	Y	N	UD, D	UD, D	N	N
<i>bfi1</i>	19	Bit Field Insert 1	Move and Logic		2	Y	N	UD, D	UD, D	N	N
<i>bfi2</i>	1A	Bit Field Insert 2	Move and Logic		3	Y	N	UD, D	UD, D	N	N
<i>bfrev</i>	17	Bit Field Reverse	Move and Logic		1	Y	N	UD	UD	N	N
<i>brc</i>	23	Branch Converging	Flow Control		0 or 1	Y	N	D		N	N
<i>brd</i>	21	Branch Diverging	Flow Control		0 or 1	Y	N	D		N	N
<i>break</i>	28	Break	Flow Control		0	Y	N			N	N



Instruction Set Summary Table C to E (Listed by Instruction Mnemonic)

Mnem.	Hex Opcode	Name	Group	Gen	Srcs	Pred?	SrcMod	Src Types	Dst Type	Sat?	CondMod?
<i>call</i>	2C	Call	Flow Control		0	Y	N		D, UD	N	N
<i>calla</i>	2B	Call Absolute	Flow Control		0	Y	N		D, UD	N	N
<i>cbit</i>	4D	Count Bits Set	Move and Logic		1	Y	N	UB, UW, UD	UD	N	N
<i>cmp</i>	10	Compare	Move and Logic		2	Y	Y	*	*	N	Y
<i>cmpn</i>	11	Compare NaN	Move and Logic		2	Y	Y	*	*	N	Y
<i>cont</i>	29	Continue	Flow Control		0	Y	N			N	N
<i>dim</i>	0A	Double Precision Floating-Point Immediate Data Move	Move and Logic		1	Y	N	F	DF	Y	Y
<i>dp2</i>	57	Dot Product 2	Vector Arithmetic		2	Y	Y	F	F	Y	Y
<i>dp3</i>	56	Dot Product 3	Vector Arithmetic		2	Y	Y	F	F	Y	Y
<i>dp4</i>	54	Dot Product 4	Vector Arithmetic		2	Y	Y	F	F	Y	Y
<i>dph</i>	55	Dot Product Homogeneous	Vector Arithmetic		2	Y	Y	F	F	Y	Y
<i>else</i>	24	Else	Flow Control		0	N	N			N	N
<i>endif</i>	25	End If	Flow Control		0	N	N			N	N



Instruction Set Summary Table F to L (Listed by Instruction Mnemonic)

Mnem.	Hex Opcode	Name	Group	Gen	Srcs	Pred?	SrcMod	Src Types	Dst Type	Sat?	CondMod?
<i>f16to32</i>	14	Half Precision Float to Single Precision Float	Move and Logic		1	Y	Y	W	F	Y	Y
<i>f32to16</i>	13	Single Precision Float to Half Precision Float	Move and Logic		1	Y	Y	F	W	Y	Y
<i>fbh</i>	4B	Find First Bit from MSB Side	Move and Logic		1	Y	N	D, UD	UD	N	N
<i>fbl</i>	4C	Find First Bit from LSB Side	Move and Logic		1	Y	N	UD	UD	N	N
<i>frc</i>	43	Fraction	Parallel Arithmetic		1	Y	Y	F	F	N	Y
<i>halt</i>	2A	Halt	Flow Control		0	Y	N			N	N
<i>if</i>	22	If	Flow Control		0	Y	N			N	N
<i>illegal</i>	00	Illegal	Special		0	N	N			N	N
<i>jmp</i>	20	Jump Indexed	Flow Control		1	Y	N	D		N	N
<i>line</i>	59	Line	Vector Arithmetic		2	Y	Y	F	F	Y	Y
<i>lrp</i>	5C	Linear Interpolation	Vector Arithmetic		3	Y	Y	F	F	N	Y
<i>lzd</i>	4A	Leading Zero Detection	Move and Logic		1	Y	Y	D, UD	UD	Y	Y



Instruction Set Summary Table M to P (Listed by Instruction Mnemonic)

Mnem.	Hex Opcode	Name	Group	Gen	Srcs	Pred?	SrcMod	Src Types	Dst Type	Sat?	CondMod?
<i>mac</i>	48	Multiply Accumulate	Parallel Arithmetic		2	Y	Y	*	*	Y	Y
<i>mach</i>	49	Multiply Accumulate High	Parallel Arithmetic		2	Y	Y	*	*	Y	Y
<i>mad</i>	5B	Multiply Add	Parallel Arithmetic		3	Y	Y	*	*	Y	Y
<i>math</i>	38	Extended Math Function	Parallel Arithmetic		2	Y	N	*	*	Y	N
<i>mov</i>	01	Move	Move and Logic		1	Y	Y	*	*	Y	Y
<i>movi</i>	03	Move Indexed	Move and Logic		1	Y	Y	*	*	Y	N
<i>mul</i>	41	Multiply	Parallel Arithmetic		2	Y	Y	*	*	Y	Y
<i>nop</i>	7E	No Operation	Special		0	N	N			N	N
<i>not</i>	04	Logic Not	Move and Logic		1	Y	**	Int	Int	N	Equality only
<i>or</i>	06	Logic Or	Move and Logic		2	Y	**	Int	Int	N	Equality only
<i>pln</i>	5A	Plane	Vector Arithmetic		2	Y	Y	F	F	Y	Y



Instruction Set Summary Table R to X (Listed by Instruction Mnemonic)

Mnem.	Hex Opcode	Name	Group	Gen	Srcs	Pred?	SrcMod	Src Types	Dst Type	Sat?	CondMod?
<i>ret</i>	2D	Return	Flow Control		1	Y	N	D, UD		N	N
<i>rndd</i>	45	Round Down	Parallel Arithmetic		1	Y	Y	F	F	Y	Y
<i>rnde</i>	46	Round to Nearest or Even	Parallel Arithmetic		1	Y	Y	F	F	Y	Y
<i>rndu</i>	44	Round Up	Parallel Arithmetic		1	Y	Y	F	F	Y	Y
<i>rndz</i>	47	Round to Zero	Parallel Arithmetic		1	Y	Y	F	F	Y	Y
<i>sad2</i>	50	Sum of Absolute Difference 2	Vector Arithmetic		2	Y	Y	B, UB	W, UW	Y	Y
<i>sada2</i>	51	Sum of Absolute Difference Accumulate 2	Vector Arithmetic		2	Y	Y	B, UB	W, UW	Y	Y
<i>sel</i>	02	Select	Move and Logic		2	Y	Y	*	*	Y	Y
<i>send</i>	31	Send Message	Miscellaneous		1	Y	N	*	*	N	N
<i>sendc</i>	32	Conditional Send Message	Miscellaneous		1	Y	N	*	*	N	N
<i>shl</i>	09	Shift Left	Move and Logic		2	Y	Y	Int	Int	Y	Y
<i>shr</i>	08	Shift Right	Move and Logic		2	Y	Y	Int	Int	Y	Y
<i>subb</i>	4F	Integer Subtraction with Borrow	Parallel Arithmetic		2	Y	N	UD	UD	N	Y
<i>wait</i>	30	Wait	Miscellaneous		1	N	N	UD	UD	N	N
<i>while</i>	27	While	Flow Control		0	Y	N			N	N
<i>xor</i>	07	Logic Xor	Move and Logic		2	Y	**	Int	Int	N	Equality only



Accumulator Restrictions

This section describes restrictions on accumulator access, general restrictions, restrictions for specific instructions, and how those specific restrictions vary for processor generations. See **Accumulator Registers** for a description of the accumulator registers.

Accumulator registers can be accessed as explicit source or destination operands, as an implicit source value when specified for a particular instruction (*sada2* for example), and as an implicit destination when the AccWrEn instruction option is used.

These general rules apply to accumulator access:

1. Flow control, *send*, *sendc*, and *wait* instructions cannot use accumulators.
2. Instructions with three source operands cannot use explicit accumulator operands. AccWrEn may be allowed for implicitly updating the accumulator.
3. Instructions that use the accumulator as an implicit source value cannot specify an explicit accumulator source operand.
4. Instructions that specify an implicit accumulator destination (with AccWrEn) cannot specify an explicit accumulator destination operand.
5. An instruction with both an explicit accumulator source operand and an explicit accumulator destination operand must specify the same accumulator register as the source and the destination.

In the table a cell is gray if it is not applicable because the instruction is not supported for that generation.

These descriptions are frequently used in this table:

- No restrictions.
- No accumulator access, implicit or explicit.
- Source operands cannot be accumulators.
- Source modifier is not allowed if source is an accumulator.
- Accumulator is an implicit source and thus cannot be an explicit source operand.
- Accumulator cannot be destination, implicit or explicit.
- AccWrEn is required. The accumulator is an implicit destination and thus cannot be an explicit destination operand.

These minor cases occur occasionally in the table:

- Integer source operands cannot be accumulators.
- No explicit accumulator access because this is a three-source instruction. AccWrEn is allowed for implicitly updating the accumulator.
- An accumulator can be a source or destination operand but not both.

A few instructions use more than one of the listed restrictions.



Accumulator Restrictions

Instruction	HSW
<i>add</i>	No restrictions.
<i>addc</i>	AccWrEn is required. The accumulator is an implicit destination and thus cannot be an explicit destination operand.
<i>and</i>	Source modifier is not allowed if source is an accumulator.
<i>asr</i>	No restrictions.
<i>avg</i>	No restrictions.
<i>bfe</i>	No accumulator access, implicit or explicit.
<i>bfi1</i>	No accumulator access, implicit or explicit.
<i>bfi2</i>	No accumulator access, implicit or explicit.
<i>bfre</i>	No accumulator access, implicit or explicit.
<i>cbit</i>	No accumulator access, implicit or explicit.
<i>cmp</i>	Accumulator cannot be destination, implicit or explicit.
<i>cmpn</i>	Accumulator cannot be destination, implicit or explicit.
<i>csel</i>	
<i>dim</i>	No restrictions.
<i>dp2</i>	Source operands cannot be accumulators.
<i>dp3</i>	Source operands cannot be accumulators.
<i>dp4</i>	Source operands cannot be accumulators.
<i>dph</i>	Source operands cannot be accumulators.
<i>f16to32</i>	No accumulator access, implicit or explicit.
<i>f32to16</i>	No accumulator access, implicit or explicit.
<i>fbh</i>	No accumulator access, implicit or explicit.
<i>fbl</i>	No accumulator access, implicit or explicit.
<i>frc</i>	No restrictions.
<i>line</i>	Source operands cannot be accumulators.
<i>lrp</i>	No explicit accumulator access because this is a three-source instruction. AccWrEn is allowed for implicitly updating the accumulator.
<i>lzd</i>	Accumulator cannot be destination, implicit or explicit.
<i>mac</i>	Accumulator is an implicit source and thus cannot be an explicit source operand.
<i>mach</i>	Accumulator is an implicit source and thus cannot be an explicit source operand. AccWrEn is required. The accumulator is an implicit destination and thus cannot be an explicit destination operand.
<i>mad</i>	No explicit accumulator access because this is a three-source instruction. AccWrEn is allowed for implicitly updating the accumulator.
<i>math</i>	No accumulator access, implicit or explicit.



Instruction	HSW
<i>mov</i>	An accumulator can be a source or destination operand but not both.
<i>movi</i>	Source operands cannot be accumulators.
<i>mul</i>	Source operands cannot be accumulators.
<i>not</i>	Source modifier is not allowed if source is an accumulator.
<i>or</i>	Source modifier is not allowed if source is an accumulator.
<i>pln</i>	Source operands cannot be accumulators.
<i>rndd</i>	No accumulator access, implicit or explicit.
<i>rnde</i>	No accumulator access, implicit or explicit.
<i>rndu</i>	No accumulator access, implicit or explicit.
<i>rndz</i>	No accumulator access, implicit or explicit.
<i>sad2</i>	Source operands cannot be accumulators.
<i>sada2</i>	Source operands cannot be accumulators.
<i>sel</i>	No restrictions.
<i>shl</i>	Accumulator cannot be destination, implicit or explicit.
<i>shr</i>	No restrictions.
<i>subb</i>	AccWrEn is required. The accumulator is an implicit destination and thus cannot be an explicit destination operand.
<i>xor</i>	Source modifier is not allowed if source is an accumulator.



Instruction Set Reference

This chapter describes the functions of 3D Media GPGPU Execution Units, listed in alphabetical order according to assembly language mnemonic.

Conventions

This section describes conventions used in instruction reference pages.

For each instruction that has source or destination types, a table lists the allowed type combinations and may also indicate the processor generations that support certain combinations. A notation like *W indicates that UW and W are both allowed. Multiple types listed together mean that any combination (Cartesian product) of the listed types is allowed.

If a source operand is floating-point, all source operands must have the same floating-point data type.

Accumulator restrictions are described in the [Accumulator Restrictions](#) section and also appear in instruction descriptions.

Pseudo Code Format

Instructions are explained in the following pseudo-code format that resembles the GEN assembly instruction format.

```
[(pred)] opcode (exec_size) dst src0 [src1]
```

Square brackets `[]` indicate that a field is optional. Saturation modifiers and instruction options are omitted for simplicity.

General Macros and Definitions

INST_MIN_SIZE is defined as a constant of 8 bytes.

```
#define INST_MIN_SIZE 8 // Instruction minimum size in bytes (for the compact instruction format)
```

The floor function converts a floating point value to an integral floating point value. For a given floating point value, from its closest two integral float values, floor returns the one that is closer to negative infinity. For example, `floor(1.3f) = 1.0f` and `floor(-1.3f) = -2.0f`.

```
float floor(float g)
{
    return maximum(any integral float f: f <= g)
}
```

The Condition function takes the conditional signals {SN, ZR, OF, IN, NC} of result, generates a Boolean value according to a conditional evaluation controlled by the conditional modifier `cmod`, and returns the Boolean.



```
Bool Condition(result, cmod)
```

The ConditionNaN function takes the conditional signals {SN, ZR, OF, IN, NC, NS} of result, generates a Boolean value according to a conditional evaluation controlled by the conditional modifier cmod, and returns the Boolean. The only difference between Condition and ConditionNaN is that ConditionNaN uses the NS (NaN of the second source) signal.

```
Bool ConditionNaN(result, cmod)
```

The Jump function jumps the instruction sequence from the current instruction location by InstCount 8-byte units, where each 16-byte native instruction is two units and each 8-byte compact instruction is one unit. If InstCount is positive and greater than zero, is an unconditional jump forward. If InstCount is negative, is an unconditional jump backward. If InstCount is zero, IP stays on the current instruction in an infinite loop.

```
void Jump(int InstCount)
{
    IP = IP + (InstCount * INST_MIN_SIZE)
}
```

Evaluate Write Enable

The WrEn should be evaluated as below.

Note: MaskCtrl = NoMask (1) skips the check for PcIP[n] == ExIP before enabling a channel.

```
if ( MaskCtrl == 1 ) {
    for ( n = 0; n < exec_size; n++ ) {
        WrEn[n] = 1;
    }
}
else {
    for ( n = 0; n < exec_size; n++ ) {
        if ( PcIP[n] == ExIP ) {
            WrEn[n] = 1;
        }
        else {
            WrEn[n] = 0;
        }
    }
}

if ( PredCtrl != 0000b ) {
    for ( n = 0; n < exec_size; n++ ) {
        WrEn[n] = WrEn[n] & PMask[n];
    }
}

for ( n = exec_size; n < 32; n++ ) {
    WrEn[n] = 0;
}
```



EUISA Instructions

Name
Addition
Addition with Carry
Arithmetic Shift Right
Average
Bit Field Extract
Bit Field Insert 1
Bit Field Insert 2
Bit Field Reverse
Branch Converging
Branch Diverging
Break
Call
Call Absolute
Compare
Compare NaN
Conditional Send Message
Continue
Count Bits Set
Dot Product 2
Dot Product 3
Dot Product 4
Dot Product Homogeneous
Double Precision Floating Point Immediate Data Move
Else
End If
Extended Math Function
Find First Bit from LSB Side
Find First Bit from MSB Side
Half Precision Float to Single Precision Float
Halt
If
Illegal
Integer Subtraction with Borrow
Jump Indexed
Leading Zero Detection
Line
Linear Interpolation
Logic And



Name
Logic Not
Logic Or
Logic Xor
Move
Move Indexed
Multiply
Multiply Accumulate
Multiply Accumulate High
Multiply Add
No Operation
Plane
Return
Round Instructions <ul style="list-style-type: none"> ▪ Round Down ▪ Round to Nearest or Even ▪ Round to Zero ▪ Round Up
Select
Send Message
Shift Left
Shift Right
Single Precision Float to Half Precision Float
Sum of Absolute Difference 2
Sum of Absolute Difference Accumulate 2
Wait Notification
While

EUISA Structures

Name
AddrSubRegNum
DstRegNum
DstSubRegNum
EU_INSTRUCTION_BASIC_ONE_SRC
EU_INSTRUCTION_BASIC_THREE_SRC
EU_INSTRUCTION_BASIC_TWO_SRC
EU_INSTRUCTION_BRANCH_CONDITIONAL
EU_INSTRUCTION_BRANCH_ONE_SRC



Name
EU_INSTRUCTION_BRANCH_TWO_SRC
EU_INSTRUCTION_COMPACT_TWO_SRC
EU_INSTRUCTION_CONTROLS
EU_INSTRUCTION_CONTROLS_A
EU_INSTRUCTION_CONTROLS_B
EU_INSTRUCTION_FLAGS
EU_INSTRUCTION_HEADER
EU_INSTRUCTION_ILLEGAL
EU_INSTRUCTION_IMM64_SRC
EU_INSTRUCTION_MATH
EU_INSTRUCTION_NOP
EU_INSTRUCTION_OPERAND_CONTROLS
EU_INSTRUCTION_OPERAND_DST_ALIGN1
EU_INSTRUCTION_OPERAND_DST_ALIGN16
EU_INSTRUCTION_OPERAND_SEND_MSG
EU_INSTRUCTION_OPERAND_SRC_REG_ALIGN1
EU_INSTRUCTION_OPERAND_SRC_REG_ALIGN16
EU_INSTRUCTION_OPERAND_SRC_REG_THREE_SRC
EU_INSTRUCTION_SEND
EU_INSTRUCTION_SOURCES_IMM32
EU_INSTRUCTION_SOURCES_REG
EU_INSTRUCTION_SOURCES_REG_IMM
EU_INSTRUCTION_SOURCES_REG_REG
ExtMsgDescpt
FunctionControl
MsgDescpt31
SrcRegNum
SrcSubRegNum

EUISA Enumerations

Name
AddrMode
ChanEn
ChanSel
CondModifier
DataType
DepCtrl
EU_OPCODE
ExecSize



Name
FC
HorzStride
PredCtrl
QtrCtrl
RegFile
RepCtrl
SFID
SrcIndex
SrcMod
ThreadCtrl
VertStride
Width



EU Programming Guide

Assembler Pragmas

Declarations

A register or a register region can be declared as a symbol using the following form

.declare <symbol> **Base**=RegFile RegBase {*.SubRegBase*} **ElementSize**=ElementSize
{**SrcRegion**=DefaultSrcRegion} {**DstRegion**=DefaultDstRegion} {**Type**=DefaultType}

The register file, the base of the register origin and the element size (in unit of bytes) are the mandatory parameters for a declared register region. Optionally, the base of the sub-register address, the default source region, the default destination region and the default type can be provided in the declaration for the symbol.

For immediate register addressing mode, the declared symbol can be used in the following Cartesian form

<symbol> (RegOff, SubRegOff) <=RegNum = *RegBase*+ **RegOff**; SubRegNum = *SubRegBase*+
SubRegOff

or in the following simplified row-aligned form

<symbol> (RegOff) <=RegNum = *RegBase*+ **RegOff**; SubRegNum = *SubRegBase*

For register-indirect-register-addressing mode, the declared symbol can be used to provide immediate address term in the following Cartesian form

<symbol> [IdxReg, RegOff, SubRegOff] <= RegNum (byte-aligned) = [**IdxReg**]+(*RegBase*+ **RegOff**)*32
+ (*SubRegBase* + **SubRegOff**)**ElementSize*

or in the following simplified row-aligned form

<symbol> [IdxReg, RegOff] <= RegNum (byte-aligned) = [**IdxReg**]+(*RegBase*+ **RegOff**)*32

or in the form without the immediate address term

<symbol> [IdxReg] <= RegNum (byte-aligned) = [**IdxReg**] + *RegBase*



Defaults and Defines

The default execution size is set according to the destination register type as the following

Destination Register Type	Default Execution Size
UB B	(16)
UW W	(16)
F UD D	(8)

The default execution size can be overwritten globally for all instructions using

.default_execution_size*(Execution_Size)*

or be set according the **destination** register type using

.default_execution_size_Type*(Execution_Size)*

The default register type can be set for all register files using

.default_register_type*Type*

or be set per register file using

.default_register_type_RegFileType

The default **source** register region for all symbols can be set using

.default_source_register_region*<VirtStride; Width, HorzStride>*

or be set per register type using

.default_source_register_region_type*<VirtStride; Width, HorzStride>*

The default **destination** register region for all symbols can be set using

.default_destination_register_region*< HorzStride>*

or be set per register type using

.default_destination_register_region_type*< HorzStride>*

Finally, the precompiler supports the string replacement statement of **.define** in the following form

.define*<symbol>Expression*

Notes:

- **.declare** does not support nesting. In other words, each symbol in **.declare** must be self defined. This would allow the pre-processor to expand all symbols in one pass.
- **.define** does support nesting. Only string substitution is supported (currently).
- White space within square, angle and round brackets are allowed for easy source code alignment.



```
//8x4 float data array and word indices.declare TransBase=r5 ElementSize=4 Region=<0;8,1>
Type=f
```

Fully-Expressed Instr

```
mov(8)?:fr[a0.0,224]<1,0>:f
```

Short-handed Instr

```
mov?:fTrans[a0.0,2]<1,0> // [a0.0+224] [a0.1+224] ... [a0.7+224]
```

Example: Declaration with Vx1 Indirect Addressing:

As width (4) is smaller than the execution region size (8), multiple indexed registers are used.

Declaration

```
//8x4 float data array and word address array.declare TransBase=r5 ElementSize=4
Region=<0;8,1> Type=f
```

Fully-Expressed Instr

```
mov(8)?:fr[a0.0,244]<4,1>:f
```

Short-handed Instr

```
mov?:fTrans[a0.0,2]<4,1> // [a0.0+224] [a0.1+224]
```

Assembly Programming Guideline

The following program skeleton illustrates the basic structure of a typical assembly program.

```
                // single line comment

/*             block comment
*/

<preproc_directive>           // macros, include, etc. Are global - handled by the pre-
processor
<preproc_directive>           // applies to all code that follows in sequence

// ----- some kernel
.kernel <kernel_name_string>   // [REQUIRED]

// ----- Register requirements -----
.reg_count_total <uint>        // [REQUIRED] a more direct way to specify the parameters
required
.reg_count_payload <uint>      // [REQUIRED] rather than indirectly adding the
                                // the payload and temps together to get the total (as is the case
now)
                                // Note: no more reg-count-temp

// ----- Defaults -----
<default...>                   // these should be specified per-kernel and have only kernel-scope
<default...>                   // Same defaults as those already defined in the ISA doc, but just
<default...>                   // moved within the kernel to make each kernel completely self-
sufficient
                                // and not impacted defaults of earlier kernels

// ----- Memory Requirements -----
// [optional] memory block info (just a placeholder for now...)
```



```
<MBDa>          // memory block descriptor a (TBD)
<MBDb>          // memory block descriptor b (TBD)
<MBDc>          // memory block descriptor c (TBD)
<MBDd>          // memory block descriptor d (TBD)

// ----- Code -----
.code           // [REQUIRED]
  <instruction>
  <instruction>
  <instruction>
<LabelLine>    // labels are code-block scope
  <instruction>
  <instruction>
.end_code      // [REQUIRED]

.end_kernel    // [REQUIRED]

// ----- next kernel -----
// ----- next kernel -----
// ...
```



Usage Examples

Vector Immediate

The immediate form of vector allows a constant vector to be in-lined in the instruction stream. An immediate vector is denoted by type `v` as `imm32:v`, where the 32-bit immediate field is partitioned into 8 4-bit subfields. Each 4-bit subfield contains a signed integer value. Therefore each 4-bit subfield has a range of [-8, +7]. This is depicted in the following figure.

31	28	27	24	23	20	19	16	15	12	11	8	7	4	3	0
V7		V6		V5		V4		V3		V2		V1		V0	

Supporting DirectX 10 Pixel Shader Indexing

When a DirectX 10 Pixel Shader program is converted to run on GEN in channel-serial mode at 16 pixels in parallel, the per-pixel index must be translated into 16 indices with per channel offset. The creation of the per-channel offset can be achieved using the vector immediate.

Consider a generic DirectX 10 Pixel Shader instruction in the form of

`opr4r[ind]r2`

and assume that `r0-r1` contain the 16 indices packed every other words, and `r2-r3` contains source 1 and `r4-r5` contain the destination. This instruction can be converted into the following GEN instructions. The corresponding operations are illustrated in *Supporting DirectX 10 Pixel Shader Indexing*.

`mov (16) r11.0<1>:w 0x01234567:v// assigning a ramp vector, repeated once`

`mul (16)acc0:wr11.0<0;16,1>:w4:w// expand ramp range to 4 bytes per step`

`mac (16)r10.0<1>:wr0.0<16;8,2>:w32:w// r10 = index*32 + 0|4|...|28|0|4...|28`

`mov (8)a0.0<1>:wr10.0<0;8,1>:w`

`op (8)r4.0<1>:fr[a0.0]<1,0>:fr2.0<0;8,1>:w// Operate on the first half`

`mov (8)a0.0<1>:wr10.8<0;8,1>:w// Index values are off by a reg (32b)`

`op (8)r5.0<1>:fr[a0.0+32]<1,0>:fr3.0<0;8,1>:w// Operate on the second half.`

Pixel Shader example using vector immediate.

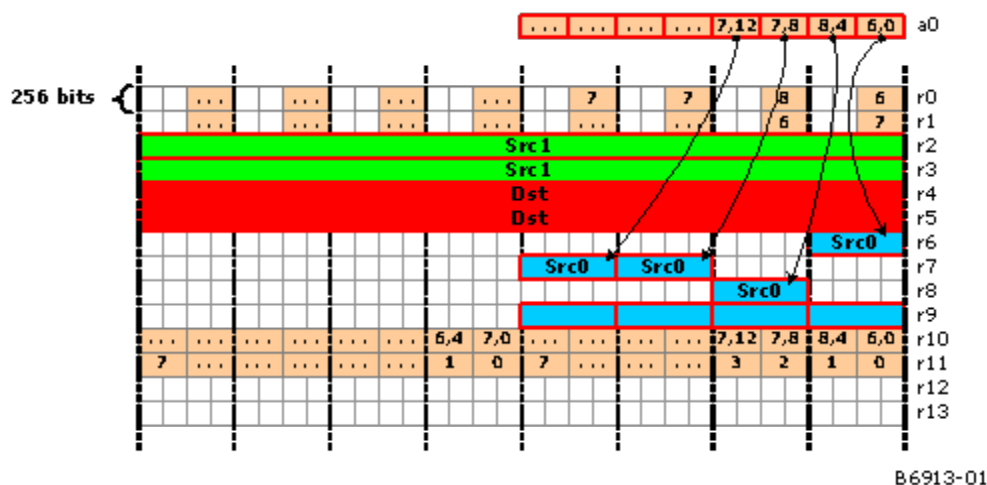

Without vector immediate support, such translation has to either use a long sequence of scalar instructions which is very inefficient or use a constant load which requires additional constant to be managed in memory.

Supporting OpenGL Vertex Shader Instruction SWZ

When an OpenGL Vertex Shader program is converted to run on GEN in Vertex Pair, i.e. two 4-wide vectors in parallel, the special OpenGL Shader instruction SWZ (Swizzle) needs to be emulated. OpenGL SWZ instruction uses an extended swizzle control field that, in addition to the 4-wide full swizzle control, also includes constant 0 and 1 replacement as well as per channel sign reversal. The later two are not supported by the GEN native instruction. The vector immediate can significantly reduce the overhead of emulating such OpenGL instruction.

Consider an OpenGL Shader instruction in the form of

SWZr1r0.0-zx-1// Expected results: r1.x = 0; r1.y = -r0.z; r1.z = r0.x; r1.w = -1

It can be emulated by the following three GEN instructions.

mul(8)r1.0<1>:fr0.xzxz0x1F111F11:v// Constant vector of (1 -1 1 1 1 -1 1 1)

mov (1)f0.0 8b'10011001// Set flag & masked out channels y and z

(f0.0)mov(8) r1.0<1>:f 0x000F000F:v// Constant vector of (0 0 0 -1 0 0 0 -1)

In case that only 0, 1, -1 channel replacement is used and there is no signed swizzle, it may be emulated in two GEN instructions. This is illustrated by the following example:

OpenGL:

SWZr1r0.0zx-1// Expected results: r1.x = 0; r1.y = r0.z; r1.z = r0.x; r1.w = -1

GEN:

mov (1)f0.0 8b'01100110// Set flag and masked out channels x and w

(f0.0)sel (8) r1.0<1>:f r0,yzxy 0x000F000F:v// Constant vector of (0 0 0 -1 0 0 0 -1)



Destination Mask for DP4 and Destination Dependency Control

The following example demonstrates the use of destination mask mode of floating point dot-product instruction as well as the use of destination dependency control to improve performance (i.e., avoiding unnecessary thread switch due to possible false dependencies).

Consider a generic DirectX 10 Vertex Shader macro of matrix-vector product that is implemented on GEN in the pair of 4-component vector mode. The DirectX 10 equivalent Shader instructions are as the following.

```
dp4 r5.x r0 r4
dp4 r5.y r1 r4
dp4 r5.z r2 r4
dp4 r5.w r3 r4
```

With destination dependency control, the GEN instructions are as the following. The first instruction in the sequence checks for the destination dependency, but does not clear the dependency bit. The subsequent two instructions would do neither of them. The last instruction avoids checking the destination dependency, but at completion, it clears the destination scoreboard. It ensures that the content of the destination register is coherent, if any of the following instructions uses the same register as source.

```
dp4 (8) r5.0<1>.x:f r0.0<4;4,1>:f r4.0<4;4,1>:f {NoDDClr}
dp4 (8) r5.0<1>.y:f r1.0<4;4,1>:f r4.0<4;4,1>:f {NoDDClr, NoDDCChk}
dp4 (8) r5.0<1>.z:f r2.0<4;4,1>:f r4.0<4;4,1>:f {NoDDClr, NoDDCChk}
dp4 (8) r5.0<1>.w:f r3.0<4;4,1>:f r4.0<4;4,1>:f {NoDDCChk}
```

Just as a comparison, IF GEN DP4 implies reduction at the destination; additional shifted moves are required to achieve the same results. The corresponding codes are as the following. The lower performance due to the additional three move instruction as well as added back-to-back dependencies shows that why we choose to implement the destination channel replication for floating point DP4.

```
dp4 (8) r5.0<1>.y:f r1.0<4;4,1>:f r4.0<4;4,1>:f
mov (1) r5.1<1>:f r8.0<1;1,1>:f
dp4 (8) r5.0<1>.z:f r2.0<4;4,1>:f r4.0<4;4,1>:f
mov (1) r5.2<1>:f r8.0<1;1,1>:f
dp4 (8) r5.0<1>.w:f r3.0<4;4,1>:f r4.0<4;4,1>:f
mov (1) r5.3<1>:f r8.0<1;1,1>:f
dp4 (8) r5.0<1>.x:f r0.0<4;4,1>:f r4.0<4;4,1>:f
```



Null Register as the Destination

Null register can be used as the destination for most of the instructions. Here are some example usages.

- Null as destination for regular ALU instructions: As all ALU instructions can be configured to update the flag registers using the conditional modifiers, it is not necessary to have a destination register if the programmer only cares about the conditionals of the operation. In that case, a null in the destination operand field saves register space as well as one less dependency checking.
- Null as the destination for SEND/STOR instructions: for the send instruction that only send messages out to an external unit and does not require any return data or feedback, a null in the destination register field signifies the case.
 - One extension of such case is that even though the operation does not have any return values, a return phase with no payload but simply updating the scoreboard flag for a non-null register can provide a signaling mechanism between the thread and the target external unit. One application of this usage is to allow software to manage the coherency of shared memory resources such like the many caches in the system (particularly, valuable for read/write caches).

Use of LINE Instruction

LINE instruction is specifically designed to speed up floating point vector/matrix computation when a program operates in channel serial.

The following example demonstrates how to use LINE instruction to compute Line Equations for DirectX 10 Pixel Shader. In this example, 2 sets of (Cx#, Cy#, don't Care, Co#) 4-tuple coefficient vectors are stored in registers R1.

R1: Cx0 Cy0 DC Co0 Cx1 Cy1 DC Co1

8 sets of coordinate 2-D vectors (X, Y) are stored in R2 and R3 in the channel serial mode as

R2: X0 X1 ... X7

R3: Y0 Y1 ... Y7

The objective is to compute the following two line equations for each set of 2D coordinate and store the results in R4 and R5 as

R4: $(X0 * Cx0 + Y0 * Cy0 + Co0) \dots (X7 * Cx0 + Y7 * Cy0 + Co0)$

R5: $(X0 * Cx1 + Y0 * Cy1 + Co1) \dots (X7 * Cx1 + Y7 * Cy1 + Co1)$

Example LINE Equations

```
//-----
```

```
// Example compute LINE equation in channel serial scenario
```

```
//-----
```

```
line (8) acc:f r1<0;1,0>:f r2<0;8,1>:f// does acc = X# * Cx0 + Co0
```



mac (8) r4<1>:f r1.1<0;1,0>:f r3<0;8,1>:f// does $r4.\# = Y\# * Cy0 + acc.\#$

line (8) acc:f r1<0;1,0>:f r2<0;8,1>:f// does $acc = X\# * Cx0 + Co0$

mac (8) r4<1>:f r1.1<0;1,0>:f r3<0;8,1>:f// does $r4.\# = Y\# * Cy0 + acc.\#$

The next example is to compute homogeneous dot product for OpenGL pixel shader running in Channel Serial. In this example, an original OpenGL PS instruction is like

dph R2.x R0 R1

With register remapping, we can store the input coefficient vector R0 in original format in r0, but 8 sets of input coordinate vectors in channel serial format in r2, r3, r4 and r5, and the destination R2.x component in r6.

r0: Cx0 Cy0 Cz0 Co0 DC DC DC DC

r2: X0 X1 ... X7

r3: Y0 Y1 ... Y7

r4: Z0 Z1 ... Z7

r5: W0 W1 ... W7

The objective is to compute the following DPH equations and store the results in r6 as

R6: $(X0 * Cx0 + Y0 * Cy0 + Z0 * Cz0 + Co0) \dots (X7 * Cx0 + Y7 * Cy0 + Z7 * Cz0 + Co0)$

Example Homogeneous Dot Product in Channel Serial

//-----

// Example compute homogeneous dot product in channel serial scenario

//-----

line (8) acc:f r0<0;1,0>:f r2<0;8,1>:f// does $acc = X\# * Cx0 + Co0$

mac (8) acc:f r0.1<0;1,0>:f r3<0;8,1>:f// does $acc.\# = Y\# * Cy0 + acc.\#$

mac (8) r6<1>:f r0.2<0;1,0>:f r4<0;8,1>:f// does $r6.\# = Z\# * Cz0 + acc.\#$

Mask for SEND Instruction

Execution mask (upto 16 bits) for the SEND instruction is transferred to the Shared Function. This provides optimized implementation of DirectX Shader instructions.

Channel Enables for Extended Math Unit

The following example demonstrates how to use the SEND instruction to get service from the Extended Math unit.

Let's consider COS instruction in DirectX 10 in the following form

`[[(!)p0.{select|any|all}]] cos[_sat] dest[_mask], [-]src0[_abs][_swizzle]`



For a SIMD4x2 VS implementation with the following register mappings

p0 =>f0.0

src0 =>r0

dest =>r1

The equivalent GEN instruction is as the following

```
[[(!]f0.0.{select[any4h|all4h}}] SEND (8) r1[.mask]:f m0 [-][!(abs)]r0[.swizzle]:f MATHBOX|COS|[SAT]
```

If the source swizzle is replication, the message description field can be modified to MATHBOX|COS|SCALAR to take advantage of the fast mode (scalar mode) supported by the Extended Math. The implied move of the SEND instruction is equivalent to the following instruction:

```
MOV (8) m0[.mask]:f [-][!(abs)]r0.0[.swizzle]:f {NoMask}
```

For a SIMD16 PS implementation, the register mappings are as the followings

p0 =>f0...f3 // in order of R, G, B, A

src0 =>r0,r1; r2,r3; r4,r5; r6,r7

dest =>r8,r9; r10,r11; r12,r13; r14,r15

There are several ways to translate the DirectX instruction, depending on the operand/instruction modifiers present in the DirectX instruction. If predicate is not present and the source swizzle is replication, say, src0.y, which is r2-r3, the translation could be as the following instructions

```
send (8) r8:f m0 -(abs)r2:f MATHBOX|COS
```

```
send (8) r9:f m1 -(abs)r3:f MATHBOX|COS {SecHalf} // use the second half of 8 flag bits
```

```
mov (16) r10:f r8:f // All destination color channels are same
```

```
mov (16) r12:f r8:f // MOV is faster than most MathBox functions
```

```
mov (16) r14:f r8:f // These MOVs are compressed instructions
```

Notice that instead of issuing Extended Math messages with the same input data, destination color channel replication is performed by the MOV instructions. This is faster for the thread for most cases as many Extended Math functions consume multiple cycles. This also conserves message bus bandwidth as well as the usage of the shared resource – Extended Math. The destination mask in the DirectX 10 instruction indicates which of the r8 to r15 registers are updated. If the source swizzle is not replication, there will be 8 SEND instructions.

With predication on, if the predication modifier is p0.select, translation is to take the selected flag register f#. The other predication modifiers .any and .all are translated into .any4v and .all4v, respectively. Notice that with predication on, it is not required to run all 4 pixels in a subspan in the same way, so no need to enforce .any4h/.any4v. The following example shows the instruction with predication (but without .select modifier).

```
(f0[.any4v|.all4v]) send (8) r8:f m0 -(abs)r2:f MATHBOX|COS
```

```
(f0[.any4v|.all4v]) send (8) r9:f m1 -(abs)r3:f MATHBOX|COS {SecHalf}
```



(f1[.any4v|.all4v]) mov (16) r10:fr8:f // All destination color channels are same

(f2[.any4v|.all4v]) mov (16) r12:fr8:f // MOV is faster than most MathBox functions

(f3[.any4v|.all4v]) mov (16) r14:fr8:f // These MOVs are compressed instructions

The same instructions works also for predication with select component modifier. We simply replase f0 to f3 above by the selected flag register, say, f1. The modifier of any4h/all4v would also work.

Channel Enables for Scratch Memory

The following example demonstrates how to use the SEND instruction to get service from the Data Port for scratch memory access.

Let's consider general instruction in DirectX 10 that uses scratch memory as a source operand

```
[[(!)p0.{select|any|all}]] add dest[.mask], [-]src0[_abs][.swizzle], [-]src1[_abs][.swizzle]
```

For a SIMD4x2 VS implementation with the following register mappings

p0 =>f0

src0 =>r0

src1 =>s2 / r10

dest =>r1

In this example, the scratch memory offset is provided by an immediate and a GRF register r10 is used as the intermediate GRF location for spill/fill of scratch buffer accesses. This arithmetic instruction is converted into a Data Port read followed by an arithmetic instruction.

```
mov (8) r3:d r0:d {NoMask} // move scratch base address to be assembled with offset values
```

```
mov (1) r3.0:d 2*32 {NoMask} // s2 for vertex 0
```

```
mov (1) r3.1:d 2*32+16 {NoMask} // s2 for vertex 1
```

```
send (8) r10 m0 r3 DATAPORT|RC|READ_SIMD2
```

```
[[(!)f0.{sel|any4h|all4h}]] add (8) r1[.mask]:f [-][abs]r0[.swizzle]:f [-][abs]r10[.swizzle]:f
```

So if scratch register is the source, there is no need to use the channel enable side band. This is also true for channel-serial PS cases.

Now, let's consider the case when a scratch register is the destination of an instruction.

p0 =>f0

src0 =>r0

src1 =>r1

dest =>s2 / r10

We have

```
add (8) m1:f [-][abs]r0[.swizzle]:f [-][abs]r1[.swizzle]:f
```



```
mov (8) r3:d r0:d {NoMask} // move scratch base address to be assembled with offset values
mov (1) r3.0:d 2*32 {NoMask} // s2 for vertex 0
mov (1) r3.1:d 2*32+16 {NoMask} // s2 for vertex 1
[[(!)f0.{sel|any4h|all4h})] send (8) null[.mask] m0 r3 DATAPORT|RC|WRITE_SIMD2
```

Notice that with a null as the posted destination register, we are able to transfer the [.mask] over the message channel enables. In many cases for scratch memory access, a write-with-commit is required, therefore, the posted destination register could be r10.

Now, let's consider the PS case when a scratch register is the destination of an instruction.

```
p0 =>f0-f4
src0 =>r0-r7
src1 =>r8-r15
dest =>s16-s23 / r16-r23
```

When predication is not on (or predication with swizzle control on), we have

```
add (16) m4:f [-][abs]r0/2/4/6_BasedOnSwizzle:f [-][abs] r8/10/12/14_BasedOnSwizzle:f
add (16) m6:f [-][abs]r0/2/4/6_BasedOnSwizzle:f [-][abs] r8/10/12/14_BasedOnSwizzle:f
add (16) m8:f [-][abs]r0/2/4/6_BasedOnSwizzle:f [-][abs] r8/10/12/14_BasedOnSwizzle:f
add (16) m10:f [-][abs]r0/2/4/6_BasedOnSwizzle:f [-][abs] r8/10/12/14_BasedOnSwizzle:f
mov (8) r3:d 0x76543210:v {NoMask} // ramp function
mul (16) acc0:d r3:d 16 {NoMask} // ramp function
add (8) acc0:d acc0:d 64 {NoMask,SecHalf} // ramp function
add (16) m2:d acc0:d 2*256 {NoMask} // ramp function
send (16) null m1 r3 DATAPORT|RC|WRITE_SIMD16
```

As there is no bit left from the unit specified descriptor field, the 4 bit mask must be put into the header field in m1, which requires at least two more instructions.

Alternatively, or for the case that predication without modifier is on, we can do a read-modify-write.

```
mov (8) r3:d 0x76543210:v {NoMask} // ramp function
mul (16) acc0:d r3:d 16 {NoMask} // ramp function
add (8) acc0:d acc0:d 64 {NoMask,SecHalf} // ramp function
add (16) m2:d acc0:d 2*256 {NoMask} // ramp function
send (16) r16 m1 r3 DATAPORT|RC|READ_SIMD16 // read from scratch
```

// some of the following four instructions may be omitted based on [.mask] field



```
[[(!]f0.{sel|any4v|all4v})] add (16) r16:f [-][!(abs)]r0/2/4/6_BasedOnSwizzle:f [-][!(abs)]  
r8/10/12/14_BasedOnSwizzle:f
```

```
[[(!]f0.{sel|any4v|all4v})] add (16) r18:f [-][!(abs)]r0/2/4/6_BasedOnSwizzle:f [-][!(abs)]  
r8/10/12/14_BasedOnSwizzle:f
```

```
[[(!]f0.{sel|any4v|all4v})] add (16) r20:f [-][!(abs)]r0/2/4/6_BasedOnSwizzle:f [-][!(abs)]  
r8/10/12/14_BasedOnSwizzle:f
```

```
[[(!]f0.{sel|any4v|all4v})] add (16) r22:f [-][!(abs)]r0/2/4/6_BasedOnSwizzle:f [-][!(abs)]  
r8/10/12/14_BasedOnSwizzle:f
```

```
mov (16) m4:f r16:f {NoMask}
```

```
mov (16) m6:f r18:f {NoMask}
```

```
mov (16) m8:f r20:f {NoMask}
```

```
mov (16) m10:f r22:f {NoMask}
```

```
send (16) null m1 null DATAPORT|RC|WRITE_SIMD16 {NoMask} // write back to scratch
```

Flow Control Instructions

Unconditional branches are performed through direct manipulation of the 32-bit IP architectural register. For example:

```
mov (1) IP <memory_address> // jump absolute  
add (1) IP IP <byte_count> // jump relative
```

Note that jump distances are specified in terms of bytes, as opposed to instruction counts in the case of *break*, *halt*, etc. To minimize confusion, an assembler-only instruction *jmp <inst_count>*, where *<inst_count>* is an immediate term, may be defined which takes an instruction count for a distance. The *jmp* pseudo-opcode can be mapped to an *add (1) ip ip <inst_count> * 16* instruction.

IP is aligned to an 8-byte boundary, thus the 3 LSBs are not maintained in the IP architectural register and should not be relied upon by software.

IP, when used as a source operand, reflects the memory address of the instruction in which it is used. The following are examples illustrating the use of IP:

```
add (1) IP 4*16 // jumps to HERE_1  
add (1) IP 0x35 // jumps to HERE_1 (4 lsbs don't-care) <instruction>  
    <instruction>
```

```
HERE_1:<instruction>HERE_2:<instruction>  
    <instruction>  
add (1) IP -2*16 // jumps to HERE_2 ...  
add (1) IP 0 // infinite loop  
add (1) IP 0xF // infinite loop ...
```

Note for Assembler: The *if/iff/else/while/break* instructions identify relative addresses as the targets of an implicit jump associated with the instruction. These are optional in the assembly syntax as the jitter can determine the location of the matching instruction (e.g. matching *endif* instruction for a given *if* instruction).



Execution Masking

Branching

Example. If / Else / EndIf

```
//-----  
// Example if/else/endif scenario  
// if (r5==r4) ...else ... end-if  
//-----  
  
...  
cmp.e.f0 (8) null r5 r4// does r5 == r4?  
(f0) if (8) HERE_1// if part - save then update IMASK;  
// or goto the else if all false  
  
...  
  
HERE_1:// now do the else part  
else (8) HERE_2// else part - invert IMASK  
// or goto the endif if all false  
  
...  
  
HERE_2:  
endif// end-if part – restore IMASK  
...// and continue...
```

If it is known that the code has no nested conditionals, a predicate can be used for a lower overhead, more efficient if/else/endif. (One must consider the probability of all channels taking the same branch, and the number of instructions under the if/else blocks as to which conditional method, predicate or mask, is most efficient).

Fast-If

Below is an example of a fast-if instruction. For the *iff* instruction, only and iff-endif construct is allowed, as opposed to a if-else-endif. Note that the target address for branching if all enabled channels fail is one instruction beyond the endif, as the *iff* does not push and update the IMask unless the branch is taken for at least one execution channel.



Example Fast If

```
//-----  
// Example – Fast If  
//One instruction overhead conditional  
//-----  
...  
cmp.e.f0 (8) null r5 r4// any flag update  
...  
(f0)iff (8) HERE_1// fast-if – only pushes IMask;  
// if execution falls through,  
// else go to HERE_1  
...  
...  
endif// end-if part – restores IMask  
HERE_1:  
...// and continue...
```

Cascade Branching

As there is no *elseif* instruction, a C-like cascade branching such as *if / elseif / else / endif*, can be realized using the basic building blocks of *if / else / endif* as shown in the following example. Notice that two *endifs* are required to pop the IStack correctly.

Example. If / Elseif / Else / EndIf

```
//-----  
// Example if/elseif/else/endif scenario  
// if (r5==r4) ...elseif (r6>r7) else ... end-if  
//-----  
...  
cmp.e.f0 (8) null r5 r4// does r5 == r4?  
(f0)if (8) HERE_1// if part - save then update IMask;  
// or go to the else part if all false  
...  
...
```



```
HERE_1:// now do the else part
else (8) HERE_2// else if part - invert IMask
// or go to the else part if all false
cmp.g.f0 (8) null r6 r7// is r6 > r7?
(f0)if (8) HERE_3// if part - save then update IMask;
// or go to the else part if all false
...
...
HERE_3:// now do the else part
else (8) HERE_4// else part - invert IMask
// or go to the end-if part if all false
...
...
HERE_4:
endif// end-if part – restore IMask for elseif
HERE_2:
endif// end-if part – restore IMask for if
....
```

Compound Branches

Compound branches are supported through the ability logically combine flag registers for each intermediate result.

Example Compound Branch

```
//-----
// Example: if (r0 > r1) OR (r2 <= r3)
//-----
...
cmp.g.f0 (8) null r0:d r1:d// r0 > r1?
cmp.le.f1 (8) null r2:d r3:d// r2 <= r3?
or (1) f0:w f0:w f1:w// combine f0 and f1
(f0) if (8) HERE_1// Can now do normal if/else
```



```
...  
...  
HERE_1:endif
```

Example Compound Branch Using 'Any' or 'All'

```
//-----  
// Example: assuming we are doing a channel-serial vector in r0-r3  
// We want to know if all components of the vector are > 0x80  
//-----  
...  
cmp.g.f0 (16) null r0 0x80// r0 > 0x80?  
cmp.g.f1 (16) null r1 0x80// r1 > 0x80?  
cmp.g.f2 (16) null r2 0x80// r0 > 0x80?  
cmp.g.f3 (16) null r3 0x80// r1 > 0x80?  
    (f0.all4v) if (16) HERE_1  
...  
...// code executed only for those channels  
...// where per-channel r0,r1,r2,r3 all > 0x80  
...  
HERE_1:endif  
...// and continue...
```

Looping

Due to GEN's SIMD-16 architecture, it must support the case of up to 16 loops running in parallel. These must be handled as independent loops, each with its own loop-exit condition which could occur after a different number of loop iterations. To account for each channel's progress, a 16b loop-mask *LMask* is defined with 1b associated to each execution channel. This mask keeps track of which channels remain active inside a loop block.

Basic Do-While Loop

Looping illustrates the most basic loop. Two operations must be accomplished before loop entry. (1) Prior to loop entry, there is some subset of enabled channels as dictated by the code sequence prior. In general, the active status of each channel is indicated in the virtual EMask any point in time. These active channels will become the channels over which the loop is run, and LMask must be initialized with the



EMask value. (2) Since a given loop may be nested within another loop, the previous LMask & CMask must be saved to the LStack for later restoration upon loop completion. The *msave* instruction performs both the save and update in a single instruction, and thus all loop-blocks should be fronted with a *msave LStack LMask* and *msave LStack CMask* operation.

Note that the LMask and CMask share the same mask-stack. Thus, CMask must always be a 1's-subset of the LMask for proper stack operation. This is the case if CMask is updated to LMask each pass through the loop (see *Looping*) and through the *break* instruction updating both masks.

Each pass through the loop, a loop terminating operation must be evaluated and stored in a flag register. This condition must be evaluated on a channel-by-channel basis as exemplified:

```
cmp.z.f0(8) null r2 d3// any operation that updates a flag
```

The result of this operation sets a bit per channel in the specified flag register, which is then used in the *while* instruction. As loops are performed, channels may become disabled as their termination condition is met.

While termination is determined on a channel-by-channel basis by the logical AND of corresponding bit positions of AMask, CMask and the specified flag. If the result is *1* the channel remains enabled for the next pass of the loop; if *0* the channel is disabled until loop fall-through. The *while* instruction causes the LMask to be updated with the latest result of enabled channels. If any channel remains enabled (LMask != ...000b), an additional pass through the loop is made. Once a channel is terminated for the loop operation, it remains terminated until the loop is complete for all channels.

Upon fall through, the *while* instruction causes the previously saved LMask & CMask to be popped from the LStack, enabling execution on the same subset of channels enabled prior to loop entry (unless a channel had been otherwise terminate inside the loop via *halt*).

Example Basic Loop Construct

```
//-----  
//Example: Basic do-while loop structure  
//-----  
...  
do// save L/CMask & update  
BEGIN_LOOP:  
mov (1) CMask LMask{NoMask}// update CMask for this pass  
...  
...  
<some flag update>  
(<p>)while (8) BEGIN_LOOP// cond. branch  
// + restores LMask on fall-through
```



...

Do-While Loop with Break

A loop may also be terminated for any channel via the *break* instruction. The *break* instruction causes the corresponding bit positions of enabled channels to be cleared in the LMask. If the updated LMask = ...000b, a branch is made to the specified instruction location. An example is shown below in which the *break* is at the same conditional-nesting level as the terminating *while*. Its primary value may simply be to support a *do...break.. while (true)* -type structure for a more direct 1:1 translation from higher-level source code.

Example Loop Construct With Non-Nested Break

```
//-----  
//Example: While-true loop  
//-----  
#define BrkCode(i,d)(i << 16) + d  
do// save L/CMask & update  
BEGIN_LOOP:  
mov (1) CMask LMask{NoMask} // update CMask for this pass  
...  
<some flag update>  
(<p>)break (8) BrkCode(0,HERE_1)// Restores LMask when all  
// channels complete loop.  
...  
...  
while (8) BEGIN_LOOP// while true  
HERE_1:  
...
```

A break condition may occur from various levels of nested-ifs. This gives rise to the possibility that a the loop may terminate from within nested *ifs*, and due to the jump inherent in the *break* instruction, the associated *endifs* are not encountered to clean-up the IStack as nesting levels are exited.

Example Loop Construct With Break From Within Nested Ifs

```
//-----  
//Example: General Loop Structure w/ break inside Ifs  
//-----
```



```
#define BrkCode(i,d)(i << 16) + d
do// save L/CMask & update
BEGIN_LOOP:
mov (1) CMask LMask{NoMask} // update CMask for this pass
...
if ...
if ...
if ...
...
(<p>)break (8) BrkCode(3,HERE_1)// we are 3 levels deep, so
...
endif
endif
endif
...
(<p>)break (8) BrkCode(0,HERE_1)
...
while (8) <flag_spec> BEGIN_LOOP// cond. branch
// + restores C/LMask on fall-through
HERE_1:
```

Do-While Loop with Continue

A continue instruction *cont* is provided skip to the next iteration of the loop. Because not all channels participating in the loop may be enabled at the time this instruction is executed, some channels may require continuation of the loop. A special mask *CMask* is defined which accounts for channels temporarily disabled for the current loop pass.

Since loops may nested, the *CMask* must be saved and restored around a loop similar to *LMask*. Since the *CMask* value within a properly constructed loop is always a subset of the *LMask*, it can share the *LStack* for storage, so long as it is pushed after *LMask* as shown in *Looping*. This save/restore operations are not required if the loop being entered does not have any occurrence of a continue instruction.

Example Do-While with Continue

```
//-----
//Example: General Loop Structure w/ basic break and cont.
```



```
//-----  
#define ContCode(i,d)(i << 16) + d  
do// save L/CMask & update  
BEGIN_LOOP:  
mov (1) CMask EMask// re-initialize CMask for this pass  
...  
...  
(<p>) cont (8) ContCode(0,HERE_1)  
...  
HERE_1:  
(<p>)while (8) BEGIN_LOOP// cond. branch  
// + restores C/LMask on fall-through  
...
```

Indexed Jump

Example Indexed Jump

```
//-----  
// Code example shows the use of jmpri to perform a case statement  
// of any number of options in 3 jumps  
//-----  
.default_execution_size 8  
...  
jmpri r0<0,1,0>// jump relative, based on r0.a.x  
// ----- Jump Table -----  
jmp HERE_0// redirect for case 0  
jmp HERE_1// redirect for case 1  
jmp HERE_2// redirect for case 2  
jmp HERE_3// redirect for case 3  
...  
HERE_0:// ... case 0 ...
```



```
...  
    jmp DONE  
HERE_1:// ... case 1 ...  
...  
    jmp DONE  
HERE_2:// ... case 2 ...  
...  
    jmp DONE  
HERE_3:// ... case 3 ...  
...  
DONE:  
...// and continue...
```